

# VIBRATORY MOTOR

## APPLICATION

These motors are designed for salt spreaders (snow & ice). They make the salt bin vibrates to prevent the salt from aggregating. They can also be used for seed, concrete and other material handling

## GENERAL SPECIFICATIONS

- Two vibration force available: 80 lbs and 200 lbs
- Enclosure: IP67
- Insulation class: B
- Harness: UL1015 2x 14 AWG 105°C cable
- Duty cycle: S1 continuous
- Bearing (DE & ODE): 608 permanently lubricated
- Brush lifetime: 1,200 hrs
- Operating temperature: -40°C to 40°C

## MOTOR SPECIFICATION

VIBRATION FORCE	VIBRATION FREQUENCY	VOLTAGE FREQUENCY	AMPERE
80 LBS	65HZ	12VDC	1.1A
200 LBS	54HZ	12VDC	1.6A

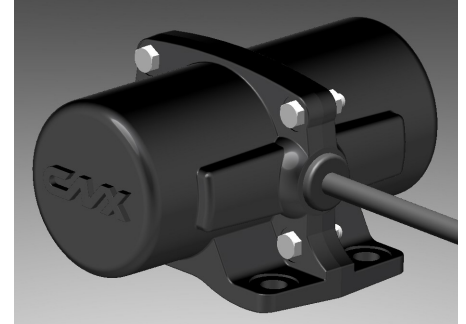

## MEASUREMENTS

VIBRATION FORCE	A	B	C	D	E	F	G	H
80 LBS	763mm 30"	126mm 5"	102mm 4"	51mm 2"	Ø20mm 0.79"	Ø11mm 0.43"	144mm 5.7"	88mm 3.5"
200 LBS	763mm 30"	126mm 5"	102mm 4"	51mm 2"	Ø20mm 0.79"	Ø11mm 0.43"	160mm 6.3"	88mm 3.5"

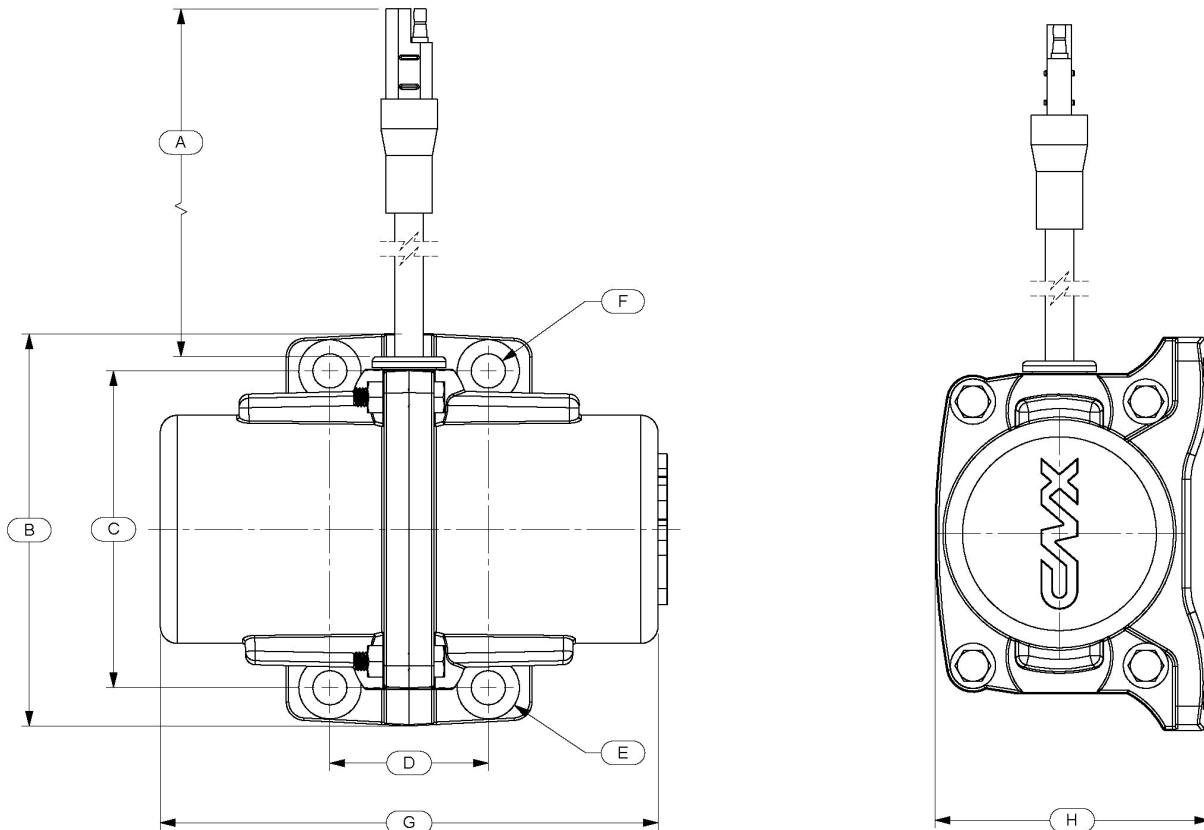

Please provide us with your drawings for any specific or additional requests.