



**SDS 180**  
**Sectional directional**  
**control valves**

**TECHNICAL CATALOG**



## Features

---

Simple, compact and heavy duty designed sectional valve from 1 to 12 sections for open and closed centre hydraulic systems.

- Fitted with a main pressure relief valve and a load check valve on every working section
- Available with parallel, tandem or series circuit.
- Optional carry-over port.
- A wide range of antishock+anticavitation port valves.
- Intermediate sections for several types of circuit.
- Available manual, pneumatic, electrohydraulic, proportional hydraulic, spool control kits.
- Diameter 20 mm (0.79 in) interchangeable spools.

### Additional information

This catalogue shows the product in the most standard configurations.  
Please contact our Sales Dpt. for more detailed information or special requests.

### WARNING!

All specifications of this catalogue refer to the standard product at this date.  
Walvoil, oriented to a continuous improvement, reserves the right to discontinue, modify or revise the specifications, without notice.

**WALVOIL IS NOT RESPONSIBLE FOR ANY DAMAGE CAUSED BY AN INCORRECT USE OF THE PRODUCT.**

10<sup>th</sup> edition December 2018

### SDS180

- Valve general informations
  - Working conditions . . . . . page 4
  - Standard threads . . . . . page 4
  - Dimensional data . . . . . page 5
  - Performance data . . . . . page 5
  - Hydraulic circuit . . . . . page 6
  - Complete sections ordering codes . . . . . page 8
  - Configuration with SDS180 and SDS150 valves coupling together ordering codes . . . . . page 10
- Inlet section
  - Parts ordering codes . . . . . page 11
  - Dimensional data and hydraulic circuit . . . . . page 12
  - Inlet relief options. . . . . page 13
- Inlet section for special application
  - Configuration with rotary commutator. . . . . page 16
  - Configuration with electric commutator . . . . . page 18
  - Configuration with flow cut-out. . . . . page 20
  - Configuration with priority valve . . . . . page 22
  - Conf. with unloader operation spool type . . . . . page 24
- Working section
  - Parts ordering codes (mechanical control) . . . . . page 26
  - Parts ordering codes (prop. hydraulic control) . . . . . page 30
  - Dimensional data and hydraulic circuit . . . . . page 32
  - Spools. . . . . page 34
  - "A" side spool positioners. . . . . page 36
  - "B" side options . . . . . page 46
  - Complete controls. . . . . page 49
  - Port valves. . . . . page 53
- Intermediate section
  - CS1 mid return manifold section. . . . . page 59
  - CS3 mid return manifold section. . . . . page 60
  - EI service relief valve section . . . . . page 61
- Outlet section
  - Parts ordering codes . . . . . page 63
  - Dimensional data and hydraulic circuit . . . . . page 63

### DLS180

- Valve general informations
  - Working conditions . . . . . page 64
  - Standard threads . . . . . page 64
  - Dimensional data . . . . . page 65
  - Performance data . . . . . page 65
  - Hydraulic circuit . . . . . page 66
  - Complete sections ordering codes . . . . . page 67
- Inlet section
  - Parts ordering codes . . . . . page 68
  - Dimensional data and hydraulic circuit . . . . . page 69
- Working section
  - Parts ordering codes (mechanical control) . . . . . page 70
  - Parts ordering codes (prop. hydraulic control) . . . . . page 71
  - Dimensional data and hydraulic circuit . . . . . page 72
  - Spools. . . . . page 72
  - "A" side spool positioners. . . . . page 73
  - "B" side options . . . . . page 74
  - Complete controls. . . . . page 75
- Outlet section
  - Dimensional data and hydraulic circuit . . . . . page 76
- Installation and maintenance . . . . . page 77
- Accessories . . . . . page 78

### Working conditions

This catalogue shows technical specifications and diagrams measured with mineral oil of 46mm<sup>2</sup>/s (46 cSt) viscosity at 40°C (104°F) temperature.

Nominal flow rating		160 l/min	42 US gpm
	for series circuit	140 l/min	37 US gpm
Max pressure <sup>(1)</sup>		315 bar	4600 psi
	for series circuit	250 bar	3600 psi
Back pressure (max.)	T outlet port	25 bar	360 psi
Internal leakage (standard) A(B)⇒T	Δp = 100 bar - 1450 psi	5 cm <sup>3</sup> /min	0.30 in <sup>3</sup> /min
Fluid		Mineral based oil	
Fluid temperature	with NBR (BUNA-N) seals	from -20°C to 80°C	from -4°F to 176°F
	with FPM (VITON) seals	from -20°C to 100°C	from -4°F to 212°F
Viscosity	operating range	from 15 to 75 mm <sup>2</sup> /s	from 15 to 75 cSt
	min.	12 mm <sup>2</sup> /s	12 cSt
	max.	400 mm <sup>2</sup> /s	400 cSt
Max. contamination level		-/19/16 - ISO 4406	NAS 1638 - class 10
Ambient temperature for working conditions	with mechanical devices	from -40°C to 60°C	from -40°F to 140°F
	with pneumatic and hydraulic devices	from -30°C to 80°C	from -22°F to 140°F
	with electric devices	from -20°C to 50°C	from -4°F to 122°F

NOTE - <sup>(1)</sup> Intermittent pressure at max. 250,000 cycles with specific internal testing.

### Standard threads

REFERENCE STANDARD				
		BSP	UN-UNF	NPTF
THREAD ACCORDING TO		ISO 228/1	ISO 263	ANSI B1.20.3
		BS 2779	ANSI B1.1 unified	
CAVITY DIMENSION ACCORDING TO	ISO	1179-1	11926-1	
	SAE		J1926-1	J476a
	DIN	3852-2 shape X or Y		

PORTS THREADING		
MAIN PORTS	BSP	UN-UNF
<b>P</b> inlet	G 3/4	1 5/16-12 (SAE 16)
<b>A</b> and <b>B</b> ports	G 3/4	1 1/16-12 (SAE 12)
<b>T</b> outlet and <b>C</b> carry-over	G 1	1 5/16-12 (SAE 16)
PILOT PORTS		
Hydraulic	G 1/4	9/16-18 (SAE 6)
Pneumatic	NPTF 1/8-27	NPTF 1/8-27

Dimensional data

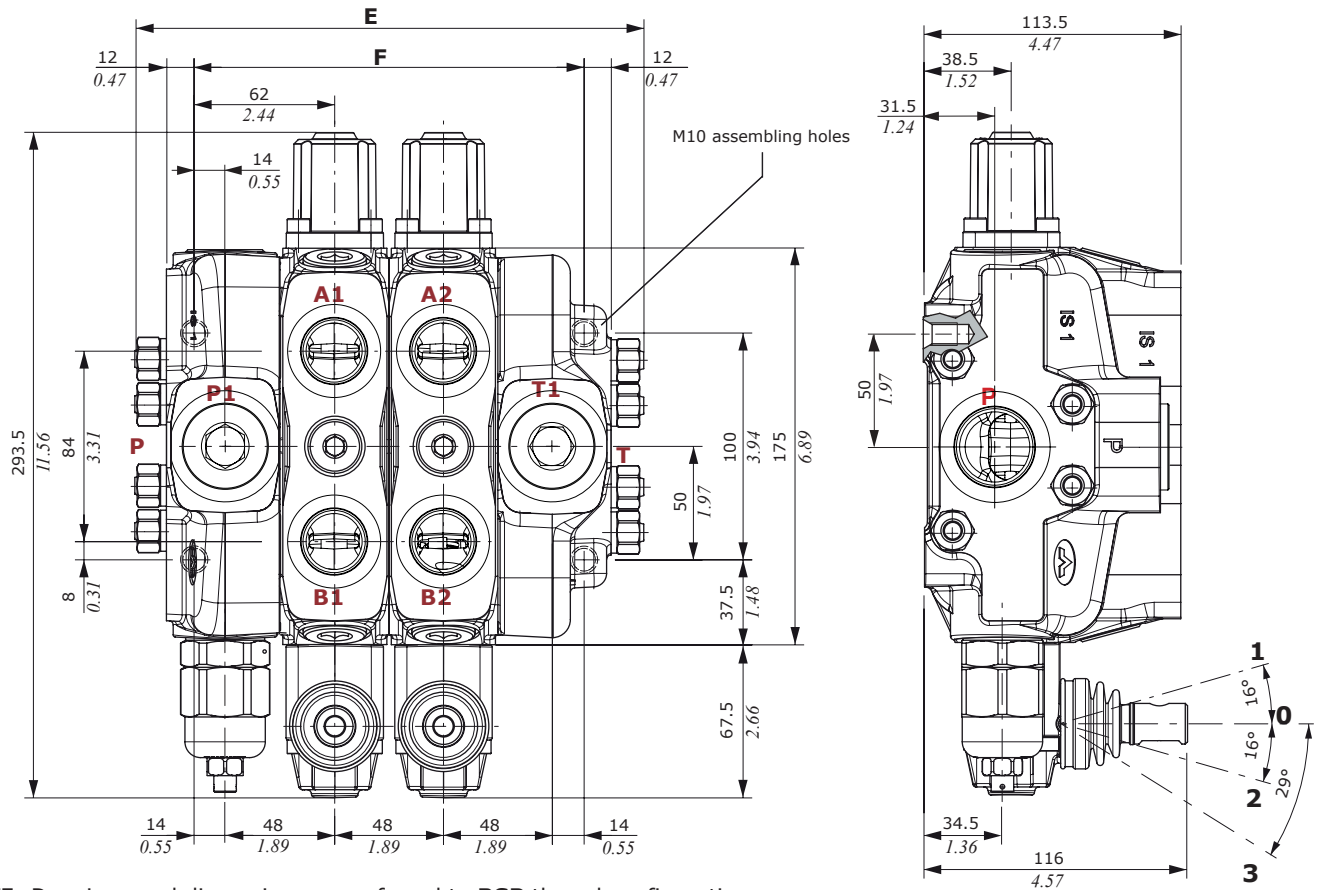

NOTE: Drawings and dimensions are referred to **BSP** thread configuration.

TYPE	E		F		Weight	
	mm	in	mm	in	Kg	lb
SDS180/1	176	6.93	124	4.88	13.8	30.42
SDS180/2	224	8.82	172	6.77	19.2	42.33
SDS180/3	272	10.71	220	8.66	24.6	54.23
SDS180/4	320	12.60	268	10.55	30	66.14
SDS180/5	368	14.49	316	12.44	35.4	78.04
SDS180/6	416	16.38	364	14.33	40.8	89.95

TYPE	E		F		Weight	
	mm	in	mm	in	Kg	lb
SDS180/7	464	18.27	412	16.22	46.2	101.85
SDS180/8	512	20.16	460	18.11	51.6	113.76
SDS180/9	560	22.05	508	20.00	57	125.66
SDS180/10	608	23.94	556	21.89	62.4	137.57
SDS180/11	656	25.83	604	23.78	67.8	149.47
SDS180/12	704	27.72	652	25.67	73.2	161.38

Performance data

P ⇒ T pressure drop

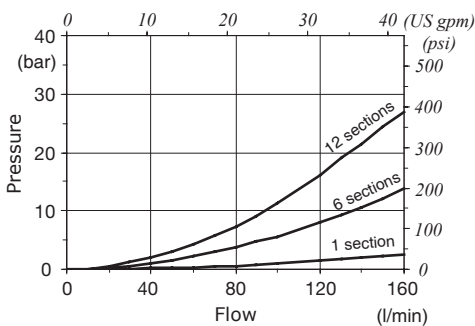

P ⇒ A(B) pressure drop

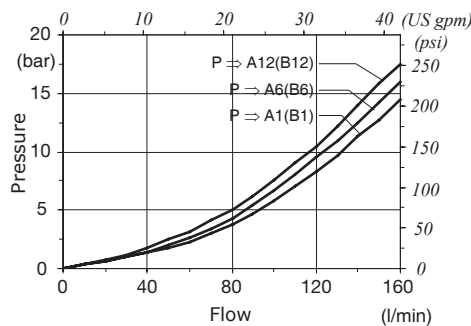

A(B) ⇒ T pressure drop

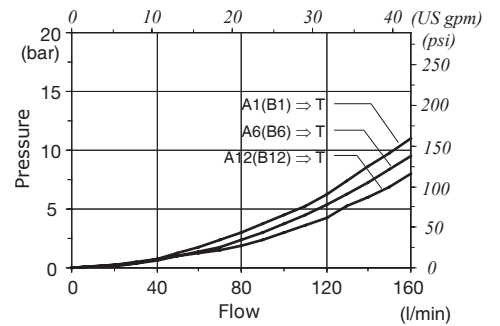

Hydraulic circuit

Parallel circuit

Standard configuration with open centre and side inlet and outlet.

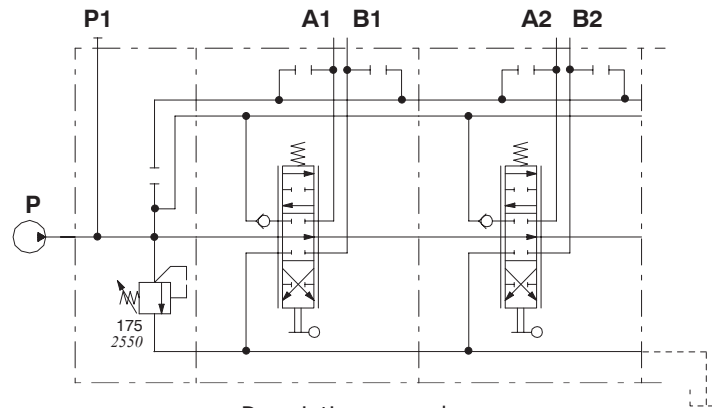

Description example:  
SDS180/2/AC(YG3-120)/18L/18L/.....

Series-parallel (tandem) circuit

It needs a special working section kit.

Tandem section is fed from the free flow pressure line; it's excluded when an up stream section is operated.

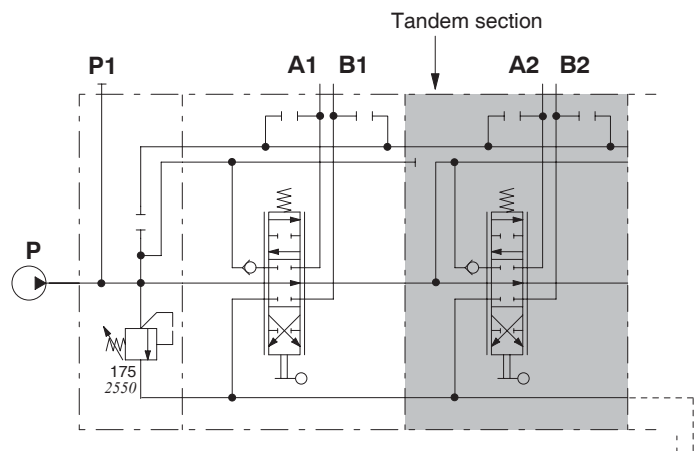

Description example:  
SDS180/2/AC(YG3-120)/18L/SP-18L/.....

Series circuit

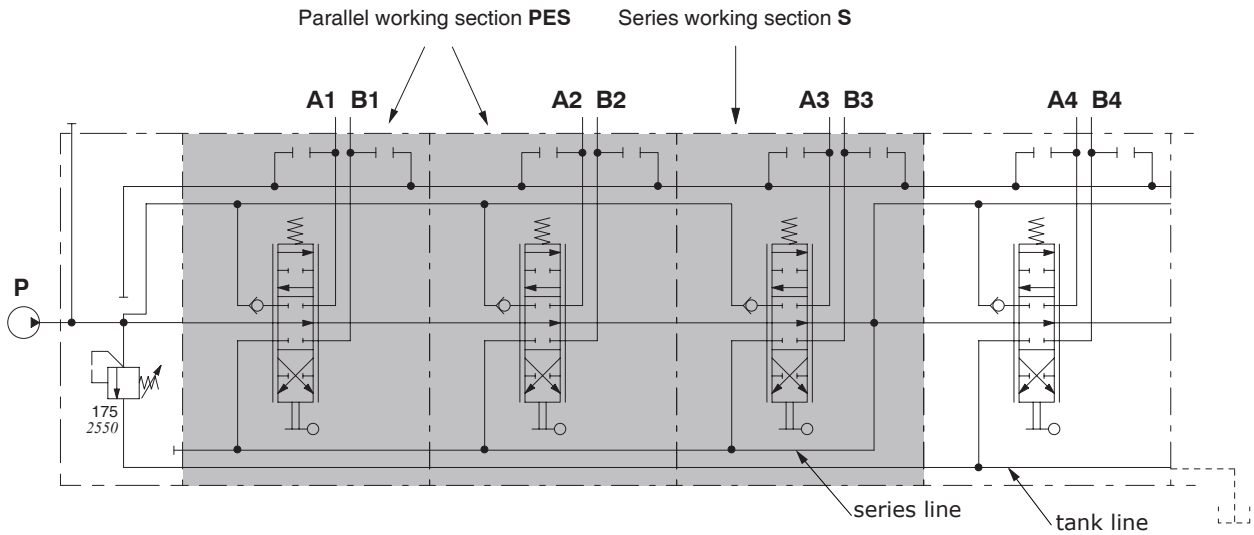

Description example:  
 SDS180/4/AC(YG3-120)/PES-18L/PES-18L/S-18L/18L/.....

Right inlet directional valve

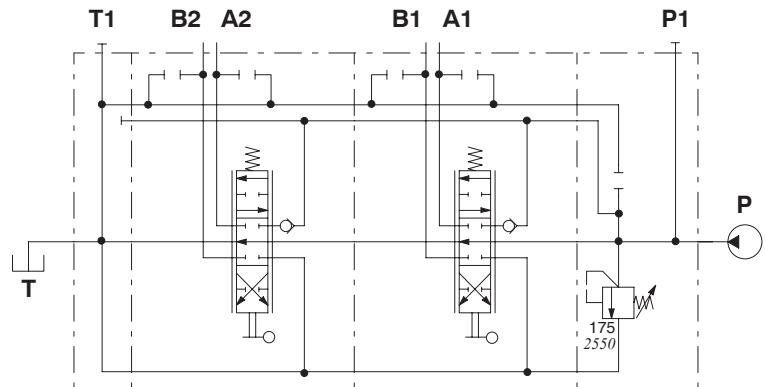
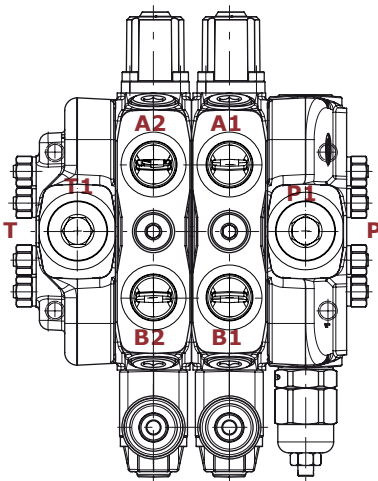

Description example:  
 SDS180/2/BC(YG3-120)/18L/18L/RC-SAE

### Complete sections ordering codes

#### Standard configuration with side inlet and outlet

**SDS180 / 2 / AC(YG3-175) / PHT-18L / E1(YG3-180) / PHT-18L / RC - SAE - STAF**

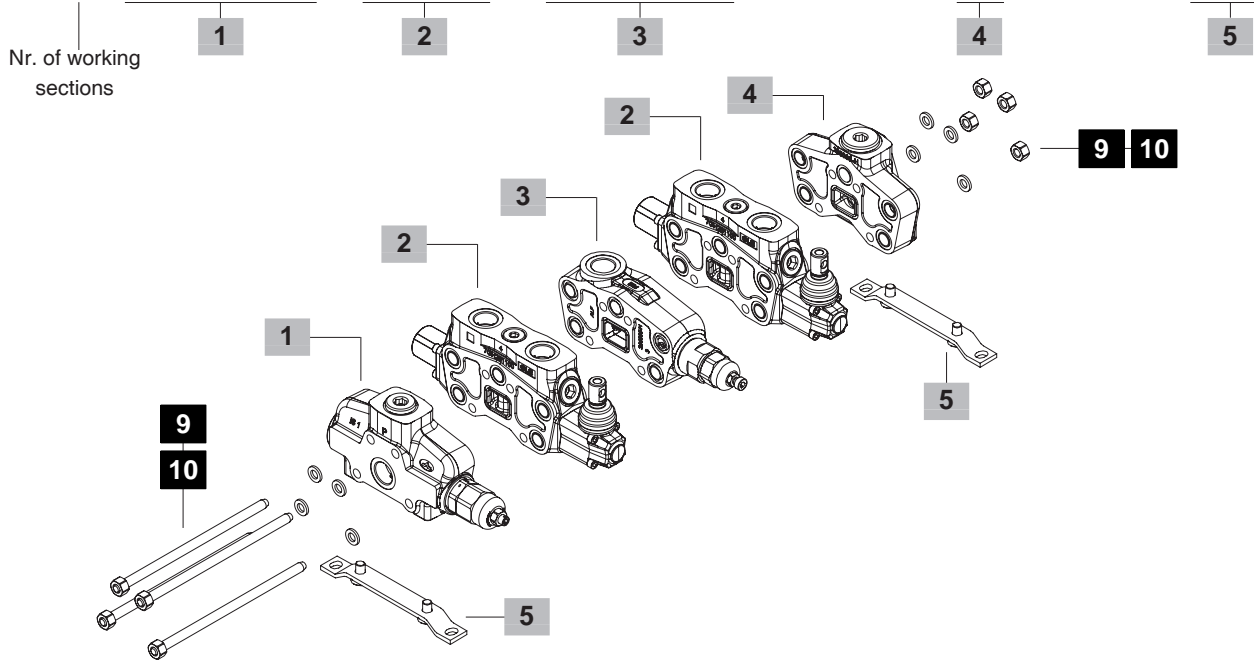

#### 1 Inlet section \* page 11

TYPE	CODE	DESCRIPTION
<b>AC(YG3-175)</b>	618205001	With direct pressure relief valve
<b>AC(XG-120)</b>	618205004	With pilot pressure relief valve
<b>AC(SV)</b>	618205006	Without pressure relief valve
<b>AC(YG3-120)R2</b>	618205016	With direct pressure relief valve and rotary commutator
<b>AC(YG3-120)R2E</b>	618205017	With direct pressure relief valve and 12VDC electric commutator
<b>M(LSW-120)ELN(NC)</b>	618205009	With flow cut-out and LS pressure relief valve
<b>ACD/VPD(LSZ-230/YG3-120)</b>	618205018	With double stage pressure relief valve and priority valve
<b>BCHW(LSW-250)ELN(NO)-24VDC</b>	618205019	With unloader operation spool type and LS pressure relief valve 24VDC

#### 2 Working section \* page 26

TYPE	CODE	DESCRIPTION
<b>PHT-18L</b>	618105150	Parallel circuit, prearranged for port valves, double acting spool with spring return, lever control
<b>RPHT-18L.U3T</b>	618105145	Parallel circuit, prearranged for valves with fixed setting
<b>RQHT-18L</b>	618105143	As previous without upper predisposition for port valves
<b>SP-18L</b>	618105017	For series-parallel (tandem) circuit, prearranged for port valves, double acting spool with spring return, lever control
<b>S-18L</b>	615115001	Series circuit, double acting spool with spring return, lever control

#### 2 Working section (continued)\* page 26

TYPE	CODE	DESCRIPTION
<b>PHT-1IM8IM</b>	618105156	Parallel circuit, prearranged for port valves with proportional hydraulic control
<b>PES-18L</b>	618105019	Parallel circuit, lever control to combine with series working section (see page 7)
<b>RPHSP-18L</b>	618125003	As RPHT for series-parallel (tandem) circuit
<b>RPHT-1IM8IM</b>	618105144	Parallel circuit for proportional hydraulic control, prearranged for valves with fixed setting
<b>RQHT-1IM8IM</b>	618105152	As previous, without upper predisposition for port valves

#### 3 Intermediate sections \* page 62

TYPE	CODE	DESCRIPTION
<b>E1(YG3)</b>	618405001	With direct pressure relief valve

#### 4 Outlet section \* page 63

TYPE	CODE	DESCRIPTION
<b>RC</b>	618305003	With side outlet
<b>RD</b>	618305002	With upper outlet
<b>RE</b>	618305001	With upper outlet and side carry-over sleeve
<b>RK</b>	618305004	With upper outlet, closed center
<b>RV</b>	618305014	With backpressure valve 10 bar (145 psi)

#### 5 Fixing bracket page 81

TYPE	CODE	DESCRIPTION
<b>STAF</b>	5STA125220	Brackets with fixing screws

NOTE (\*) - Codes are referred to **UN-UNF** thread.



**Configuration with 2 side inlets and mid return manifold**

**SDS180 / 2 / AC(YG3-120) / PHT-18L / CS1 / PHT-ED-18L / BC(YG3-120) - SAE - STAF**

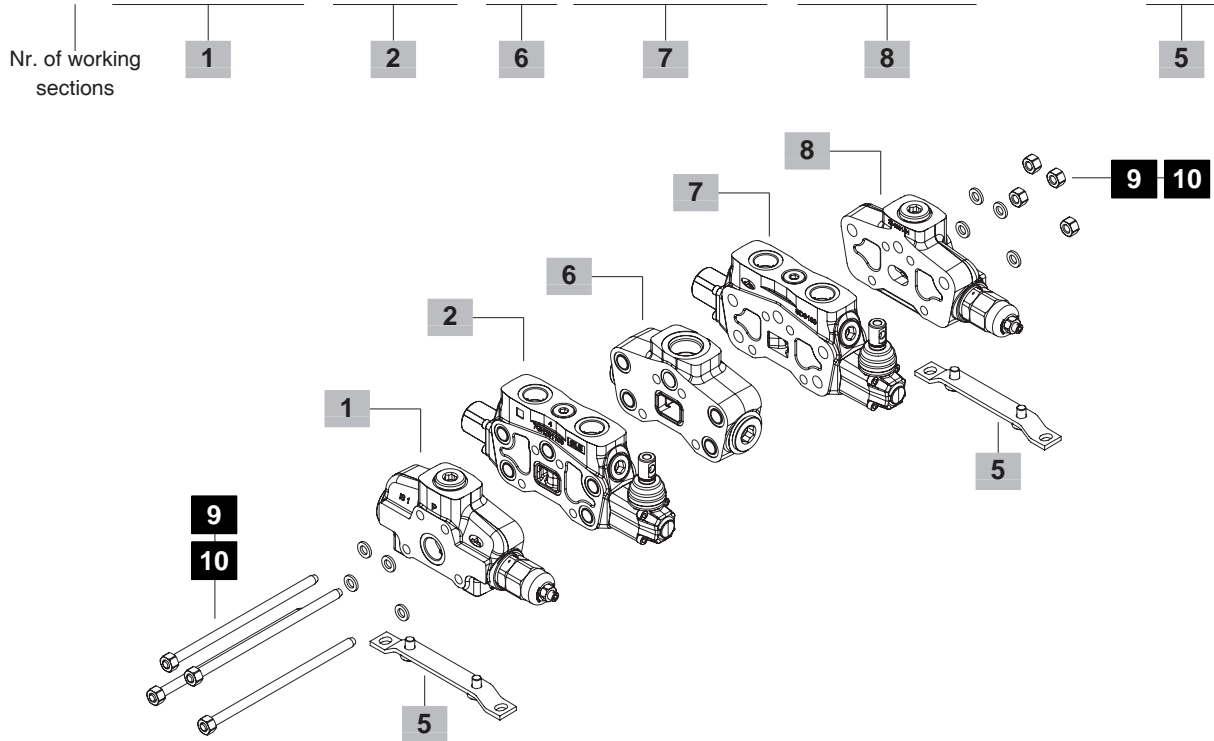

**6 Return manifold \*** page 59

TYPE	CODE	DESCRIPTION
<b>CS1</b>	615405010	Mid return manifold

**7 Right inlet working section \***

TYPE	CODE	DESCRIPTION
<b>PHT-ED-18L</b>	618101120	Parallel circuit, prearranged for port valves, double acting spool with spring return, lever control
<b>SP-ED-18L</b>	618105050	As previous with series-parallel (tandem) circuit

**8 Right inlet section \***

TYPE	CODE	DESCRIPTION
<b>BC(YG3-120)</b>	618205025	Side inlet with direct press. relief valve
<b>BC(XG-120)</b>	618205026	Side inlet with pilot pressure relief valve
<b>BC(SV)</b>	618205027	Side inlet without pressure relief valve
<b>BD(YG3-120)</b>	618205028	Upper inlet with direct pressure relief valve

**9 Assemb. kit without intermediate section**

CODE	DESCRIPTION
5TIR110170	Tie rod kit for 1 working section directional valve
5TIR110218	Tie rod kit for 2 working sections directional valve
5TIR110266	Tie rod kit for 3 working sections directional valve
5TIR110316	Tie rod kit for 4 working sections directional valve
5TIR110368	Tie rod kit for 5 working sections directional valve
5TIR110410	Tie rod kit for 6 working sections directional valve
5TIR110458	Tie rod kit for 7 working sections directional valve
5TIR110506	Tie rod kit for 8 working sections directional valve
5TIR110554	Tie rod kit for 9 working sections directional valve
5TIR110602	Tie rod kit for 10 working sections directional valve
5TIR110650	Tie rod kit for 11 working sections directional valve
5TIR110698	Tie rod kit for 12 working sections directional valve

**10 Assemb. kit with intermediate section**

CODE	DESCRIPTION
5TIR110266	Tie rod kit for 2 working sections directional valve
5TIR110316	Tie rod kit for 3 working sections directional valve
5TIR110368	Tie rod kit for 4 working sections directional valve
5TIR110410	Tie rod kit for 5 working sections directional valve
5TIR110458	Tie rod kit for 6 working sections directional valve
5TIR110506	Tie rod kit for 7 working sections directional valve
5TIR110554	Tie rod kit for 8 working sections directional valve
5TIR110602	Tie rod kit for 9 working sections directional valve
5TIR110650	Tie rod kit for 10 working sections directional valve
5TIR110698	Tie rod kit for 11 working sections directional valve
5TIR110746	Tie rod kit for 12 working sections directional valve

NOTE (\*) - Codes are referred to **UN-UNF** thread.

Configuration with SDS180 and SDS150 valves coupling together ordering codes

SDS180/2/AC(YG3-120)/PHT-18L/PHT-18L/CS3/PHT-18L/PHT-18L/BC(YG3-120)/SDS150/2-SAE

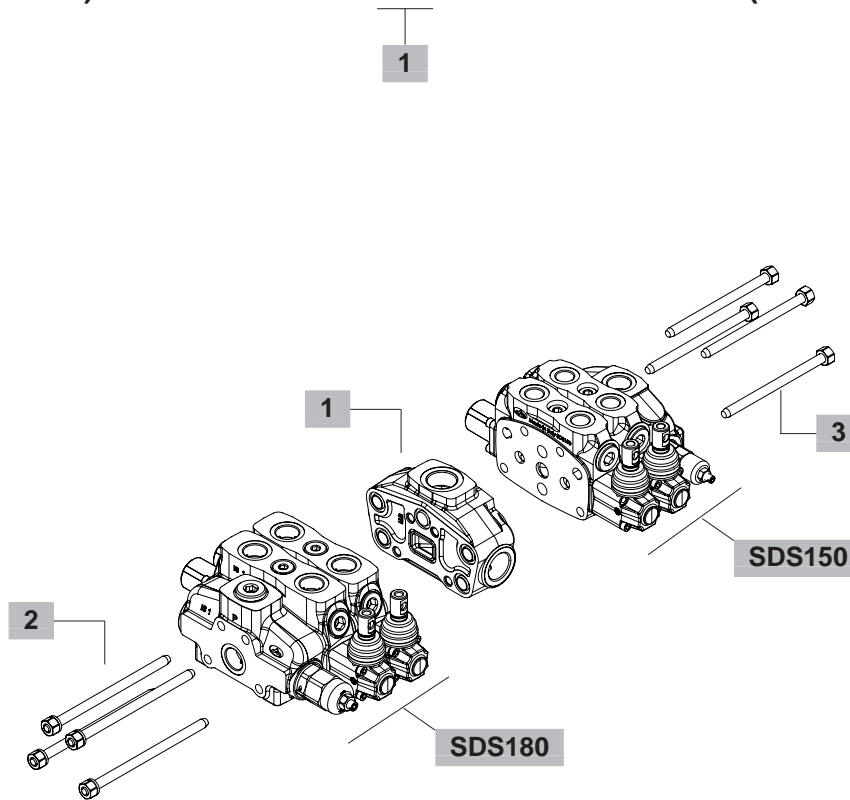

### 1 Return manifold \*

TYPE	CODE	DESCRIPTION
CS3	615445010	Mid return manifold

### 2 Assembling kit for SDS180 valve side

CODE	DESCRIPTION
5TIR4161	Tie rod kit for 1 working section directional valve
5TIR4162	Tie rod kit for 2 working sections directional valve
5TIR4163	Tie rod kit for 3 working sections directional valve
5TIR4164	Tie rod kit for 4 working sections directional valve
5TIR4165	Tie rod kit for 5 working sections directional valve
5TIR4166	Tie rod kit for 6 working sections directional valve
5TIR4167	Tie rod kit for 7 working sections directional valve
5TIR4168	Tie rod kit for 8 working sections directional valve
5TIR4169	Tie rod kit for 9 working sections directional valve
5TIR416A	Tie rod kit for 10 working sections directional valve

### 3 Assembling kit for SDS150 valve side

CODE	DESCRIPTION
5TIR41501	Tie rod kit for 1 working section directional valve
5TIR41502	Tie rod kit for 2 working sections directional valve
5TIR41503	Tie rod kit for 3 working sections directional valve
5TIR41504	Tie rod kit for 4 working sections directional valve

NOTE (\*) – Codes are referred to **UN-UNF** thread.

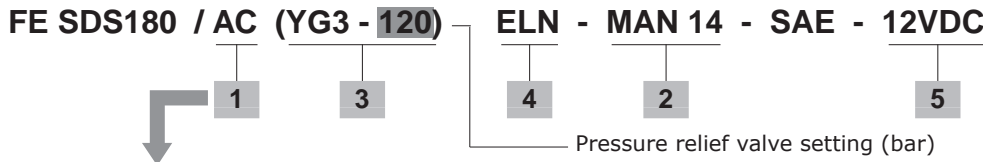

**Available configurations**

- AC:** with side inlet, for left inlet (standard) directional valve
- AD:** with upper inlet, for left inlet (standard) directional valve
- BC:** with side inlet, for right inlet directional valve
- BD:** with upper inlet, for right inlet directional valve

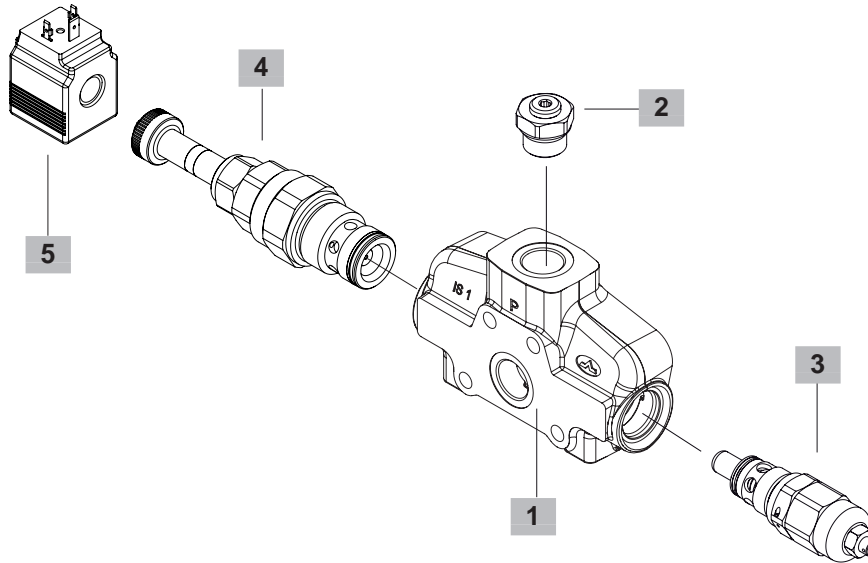

**1 Inlet cover body \*** **page 12**

CODE: 3FIA118701-H  
DESCRIPTION: Standard body

**2 Parts \***

TYPE	CODE	DESCRIPTION
-	3XTAP838200	SAE16 plug (omit in description)
<b>SAE16-MAN1/4</b>	5MAN641250	Pressure gauge arrangement
<b>SAE16-SAE6</b>	5MAN641251	Pressure gauge arrangement

**3 Inlet relief valve options** **page 13**

Standard setting is referred to 10 l/min (2.6 US gpm) flow.

TYPE	CODE	DESCRIPTION
<b>SV</b>	3XTAP535410	Relief valve blanking plug
<b>VMP20/1 pilot operated pressure relief valve X type</b>		
<b>(XG-120)</b>	X007211120	Range 60-315 bar (870-4570 psi) standard setting 120 bar (1750 psi)
<b>(XGN-120)</b>	XCAR120313	As previous without filter
<b>VMD20/1 direct pressure relief valve Y type (standard)</b>		
<b>(YG2-80)</b>	3XCAR120212	Range 63-125 bar (900-1800 psi) standard setting 80 bar (1150 psi)
<b>(YG3-175)</b>	3XCAR120213	Range 100-200 bar (1450-2900 psi) standard setting 175 bar (2500 psi)
<b>(YG4-250)</b>	3XCAR120214	Range 160-320 bar (2300-4650 psi) standard setting 250 bar (3600 psi)
<b>Double stage relief valve (pilot port SAE 8)</b>		
<b>(XGD-205-230)</b>	1130040408	Setting 205 and 230 bar (2970 and 3300 psi)

**4 Inlet valve options** **page 15**

TYPE	CODE	DESCRIPTION
-	3XTAP535410	Relief valve blanking plug (omit in description)
<b>F</b>	5KIT420200	Inlet anti-cavitation valve
<b>L</b>	3XCAR420300	Hydraulic operated
<b>Solenoid operated unloader valve</b>		
<b>ELN</b>	YEF08002000	Without emergency
<b>ELP</b>	YEF08002002	Push-button emergency
<b>ELV</b>	YEF08002003	Screw type emergency
<b>ELT</b>	YEF08002004	Push and twist type with detent emergency

**5 Coils** **page 79**

TYPE	CODE	DESCRIPTION
<b>12VDC</b>	4SLE001200A	<b>BER</b> type, 12 VDC, ISO4400 connector For complete available coils list see page 78

NOTE (\*) – Codes are referred to **UN-UNF** thread.

## Dimensional data and hydraulic circuit

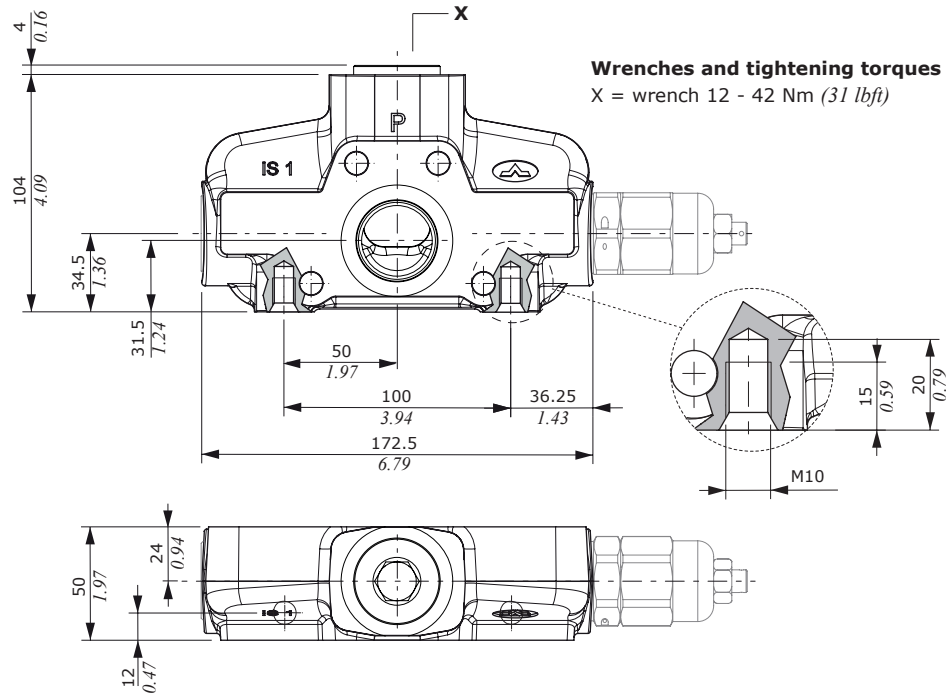

For left inlet directional valve, side port

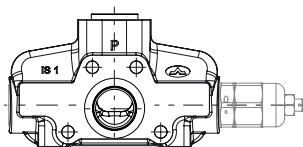
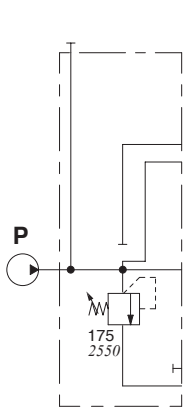

Description example:  
**AC**(YG3-175)

For left inlet directional valve, upper port

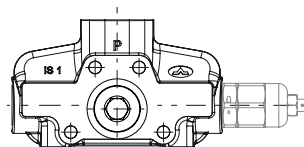
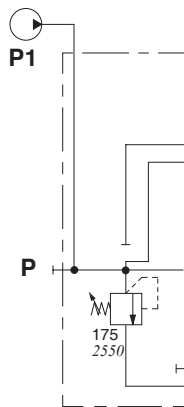

Description example:  
**AD**(YG3-175)

For right inlet directional valve, side port

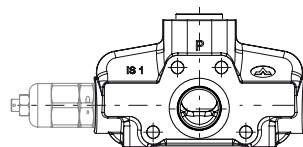
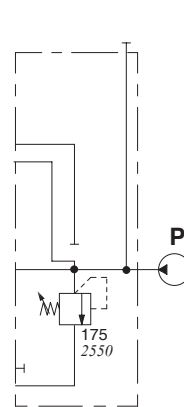

Description example:  
**BC**(YG3-175)

For right inlet directional valve, upper port

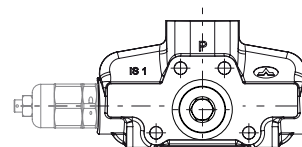
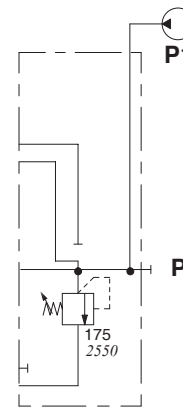

Description example:  
**BD**(YG3-175)

**Direct overpressure relief valve**

Description example: **Y G 3 - 120 - SAE**



Configuration **G** type: adjustable with screw

Configuration **H** type: valve set and locked

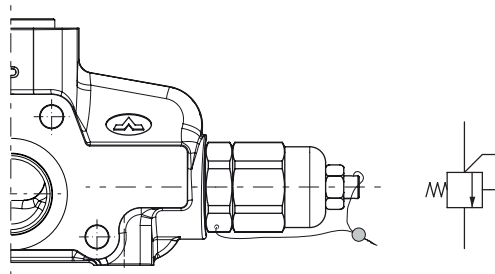
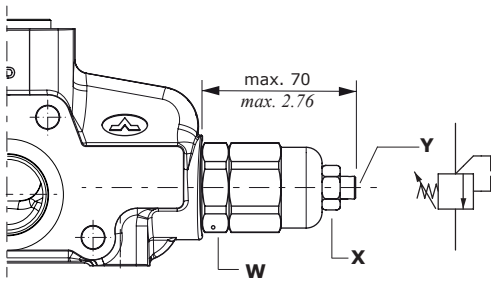

**Wrenches and tightening torques**

- X = wrench 17 - 24 Nm (17.7 lbf<sup>t</sup>)
- Y = allen wrench 5
- W = wrench 36 - 42 Nm (31 lbf<sup>t</sup>)

**YG2 valve setting range**

From 63 to 125 bar (from 900 to 1800 psi)

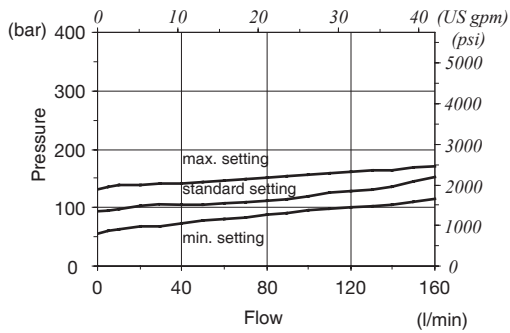

**YG3 valve setting range**

From 100 to 200 bar (from 1450 to 2900 psi)

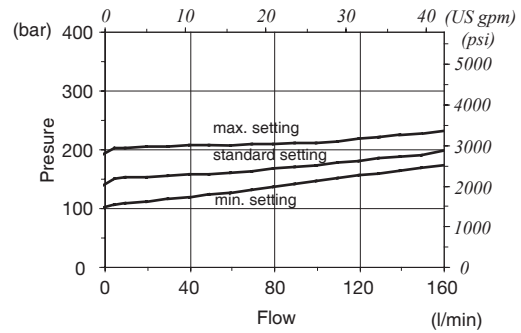

**YG4 valve setting range**

From 160 to 320 bar (from 2300 to 4650 psi)

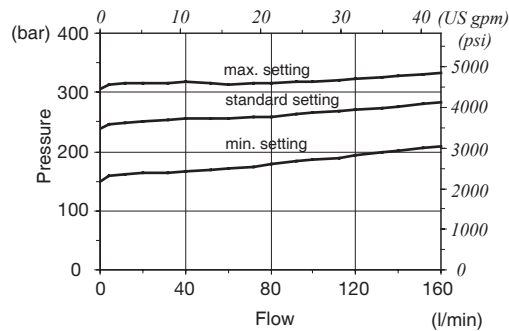

## Inlet valve options

### Pilot operated overpressure relief valve

Description example: **X G N - 120 - SAE**

Configuration — Valve setting (bar)  
 — Without filter

Configuration **G** type: adjustable with screw

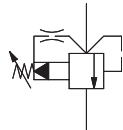
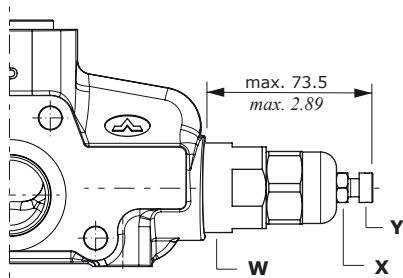

#### Wrenches and tightening torques

- X = wrench 13 - 24 Nm (17.7 lbf<sub>t</sub>)
- Y = allen wrench 5
- W = wrench 36 - 42 Nm (31 lbf<sub>t</sub>)

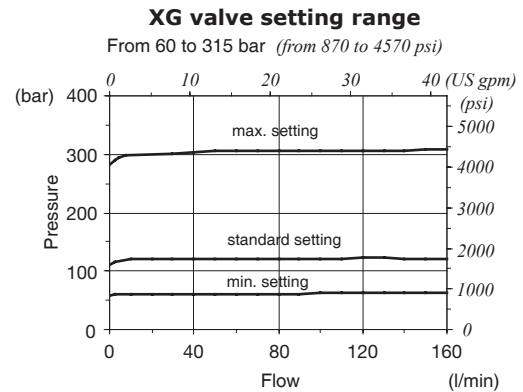

Configuration **Z** type: valve set and locked with with tamper proof cap

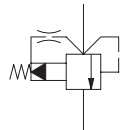
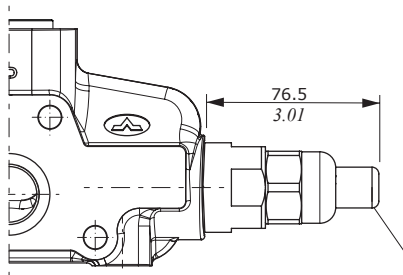

cap, code: 3COP118190

### Double stage relief valve

Description example: **X G D - 207-235**

#### Wrenches and tightening torques

- Z = wrench 36 - 42 Nm (31 lbf<sub>t</sub>)
- Y = allen wrench 36

Valve setting (bar)

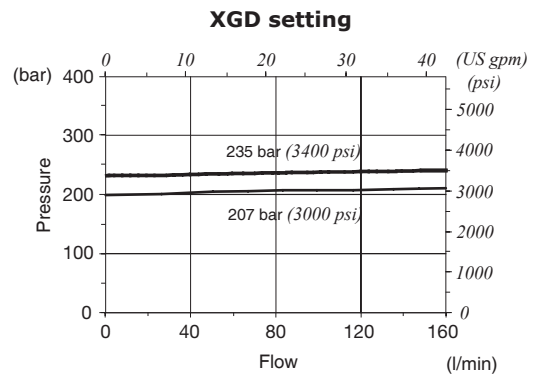
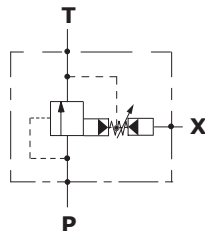
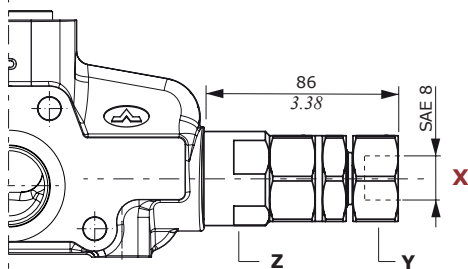

Note: valve with SAE pilot; for executions with different thread contact the Sales Dpt.

**Unloader valves**

Description example: AC (YG3 - 120) **ELT - 12VDC - SAE**

Hydraulic operated valve: **L**  
 Solenoid operated valve: **ELN**  
   **ELP**  
   **ELV**  
   **ELT**

Feeding voltage: for solenoid operated

**Solenoid operated**

**WARNING:** the manual override option is intended for emergency use, not for continuous duty operation.

**Hydraulic operated**

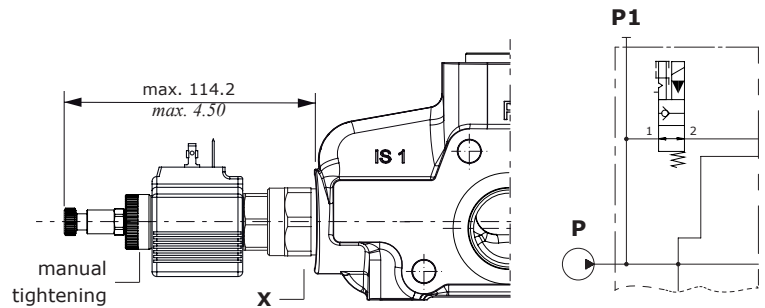
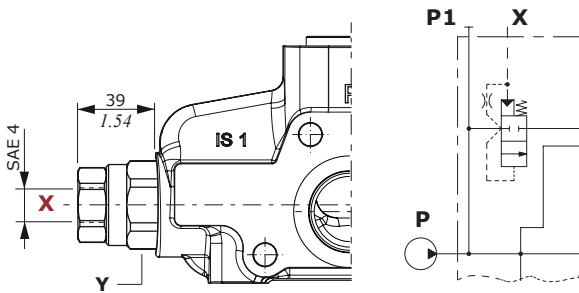

**Wrenches and tightening torques**

- Legenda**  
 Y = wrench 36 - 42 Nm (31 lbf)  
**ELN:** without emergency  
**ELP:** push button emergency override  
**ELV:** screw emergency override  
**ELT:** "push&twist" emergency override

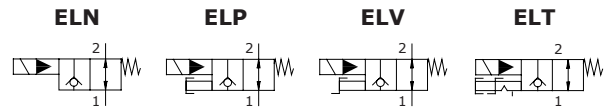

**Pressure drop valve L type on SDS180/2**

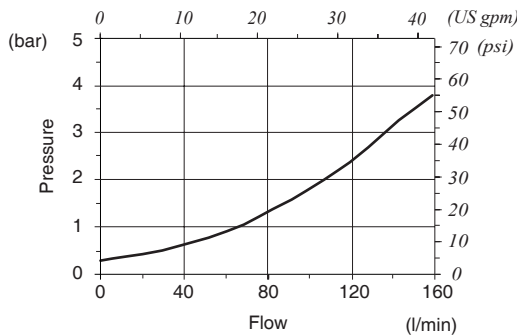

**Valve L type features**

- Nominal flow . . . . .: 120 l/min (31.7 US gpm)
- Internal leakage . . . . .: 10 cm<sup>3</sup>/min @ 100 bar (0.61 in<sup>3</sup>/min @ 1450 psi)

**Pressure drop valve EL type on SDS180/2**

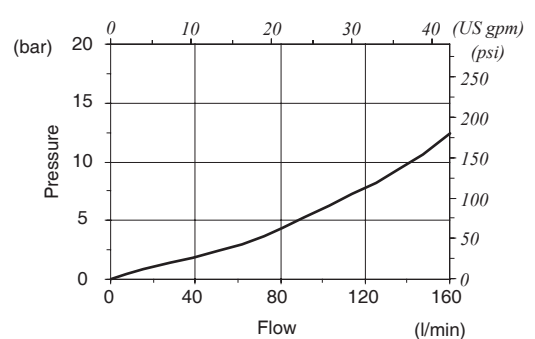

**Valve EL type features**

- Nominal flow . . . . .: 40 l/min (10.6 US gpm)
- Max. pressure . . . . .: 350 bar (5100 psi)
- Internal leakage . . . . .: 50 cm<sup>3</sup>/min @ 210 bar (3.05 in<sup>3</sup>/min @ 3050 psi)

For coil **BER** see page 79

**Anti-cavitation valve**

Description example: AC (YG3 - 120) **F**

**Wrenches and tightening torques**  
 X = wrench 32 - 9.8 Nm (7.23 lbf)

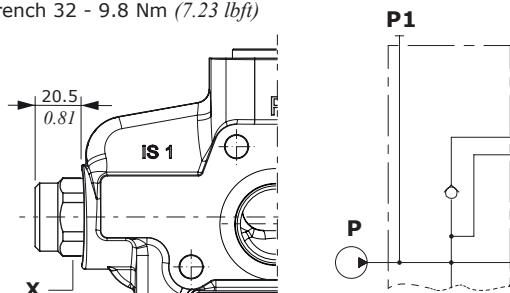

**Pressure drop**

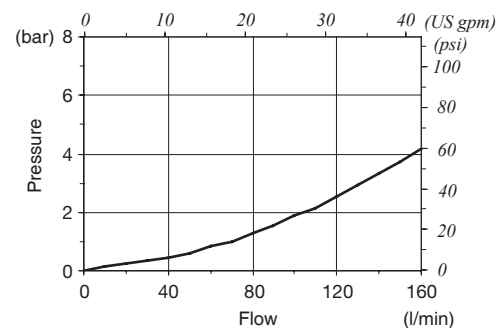

## Configuration with rotary commutator

### FE SDS180 / AC ELN - 12VDC - R2 - SAE

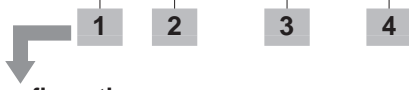

#### Available configurations

- AC:** with side inlet, for left inlet (standard) directional valve
- AD:** with upper inlet, for left inlet (standard) directional valve
- BC:** with side inlet, for right inlet directional valve
- BD:** with upper inlet, for right inlet directional valve

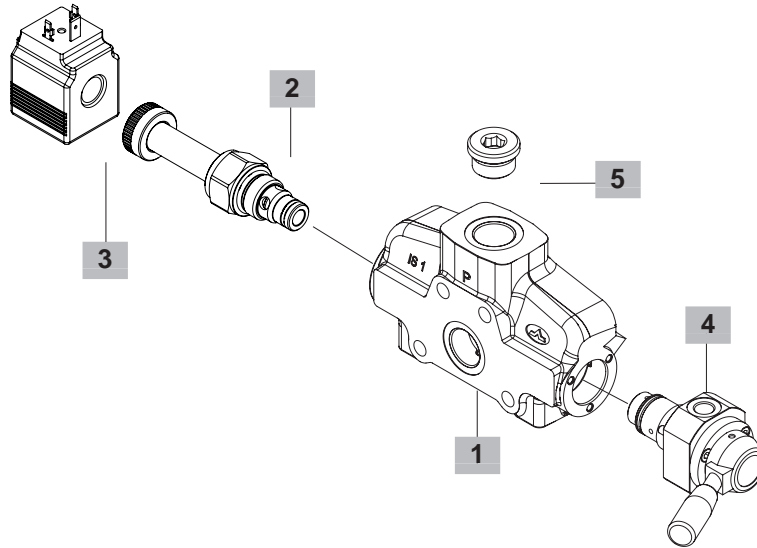

#### 1 Inlet cover body \* page 17

CODE: 3FIA118711-H  
DESCRIPTION: Predisposition for rotary commutator

#### 2 Inlet valve options page 13

Standard setting is referred to 10 l/min (2.6 US gpm) flow.

##### INLET RELIEF OPTIONS

TYPE	CODE	DESCRIPTION
<b>SV</b>	3XTAP535410	Relief valve blanking plug
<b>VMP20/1 pilot operated pressure relief valve X type</b>		
<b>(XG-120)</b>	X007211120	Range 60-315 bar (870-4570 psi) standard setting 120 bar (1750 psi)
<b>(XGN-120)</b>	XCAR120313	As previous without filter
<b>VMD20/1 direct pressure relief valve Y type (standard)</b>		
<b>(YG2-80)</b>	3XCAR120212	Range 63-125 bar (900-1800 psi) standard setting 80 bar (1150 psi)
<b>(YG3-175)</b>	3XCAR120213	Range 100-200 bar (1450-2900 psi) standard setting 175 bar (2500 psi)
<b>(YG4-250)</b>	3XCAR120214	Range 160-320 bar (2300-4650 psi) standard setting 250 bar (3600 psi)

##### Double stage relief valve (pilot port SAE 8)

<b>(XGD-205-230)</b>	1130040408	Setting 205 and 230 bar (2970 and 3330 psi)
----------------------	------------	--

##### INLET VALVE OPTIONS

<b>F</b>	5KIT420200	Inlet anti-cavitation valve
<b>L</b>	3TAP430402	Hydraulic operated unloader valve

##### Solenoid operated unloader valve

<b>ELN</b>	YEF08002000	Without emergency
<b>ELP</b>	YEF08002002	Push-button emergency
<b>ELV</b>	YEF08002003	Screw type emergency
<b>ELT</b>	YEF08002004	Push and twist type with detent emergency

#### 3 Coils page 79

TYPE	CODE	DESCRIPTION
<b>12VDC</b>	4SLE001200A	<b>BER</b> type, 12VDC, ISO4400 connector For complete available coils list see page 76

#### 4 Commutator \*

TYPE	CODE	DESCRIPTION
<b>R2</b>	5COM416200	Rotary commutator

#### 5 Parts \*

CODE	DESCRIPTION
3XTAP838200	SAE16 Plug

NOTE (\*) – Codes are referred to **UN-UNF** thread.



Configuration with rotary commutator

Dimensional data and hydraulic circuit

Drawing and circuit are referred to left inlet directional valve.

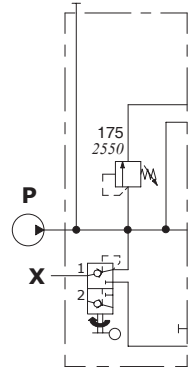
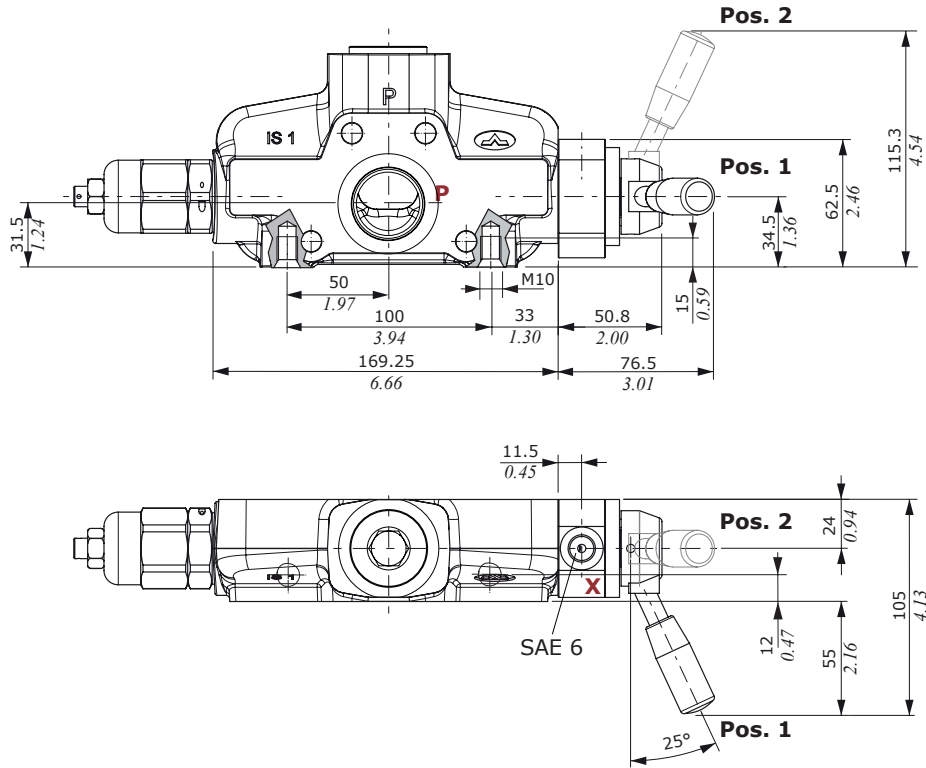

Rotary commutator features

Max. pressure . . . . .: 210 bar (3050 psi)

Internal leakage . . . . .: 3 cm<sup>3</sup>/min @ 100 bar

(0.18 in<sup>3</sup>/min @ 1450 psi)

## Configuration with electric commutator

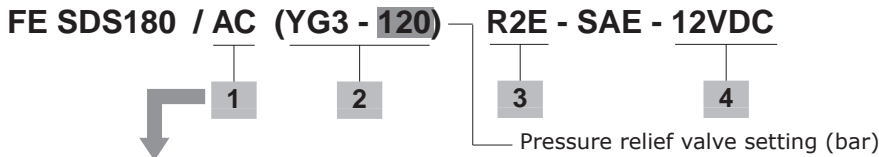

### Available configurations

- AC: with side inlet, for left inlet (standard) directional valve
- AD: with upper inlet, for left inlet (standard) directional valve

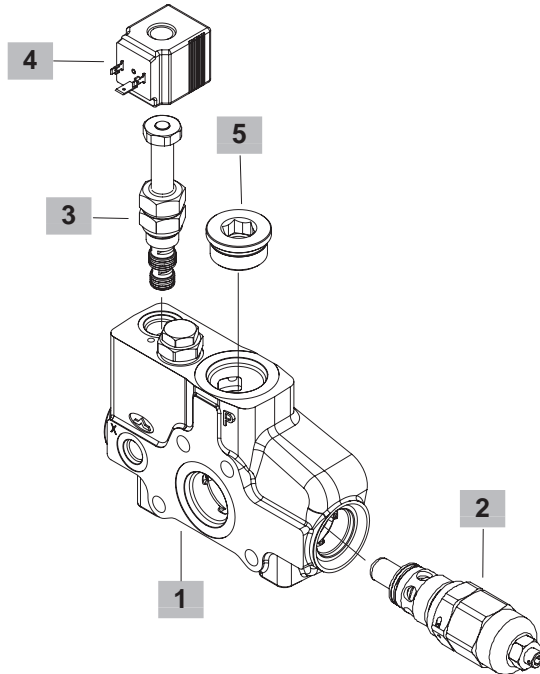

### 1 Inlet cover body \* page 19

CODE: 5FIA118761  
DESCRIPTION: Predisposition for electric commutator

### 2 Inlet valve options page 13

Standard setting is referred to 10 l/min (2.6 US gpm) flow.

#### INLET RELIEF OPTIONS

TYPE	CODE	DESCRIPTION
SV	3XTAP535410	Relief valve blanking plug
<b>VMP20/1 pilot operated pressure relief valve X type</b>		
(XG-120)	X007211120	Range 60-315 bar (870-4570 psi) standard setting 120 bar (1750 psi)
(XGN-120)	XCAR120313	As previous without filter
<b>VMD20/1 direct pressure relief valve Y type (standard)</b>		
(YG2-80)	3XCAR120212	Range 63-125 bar (900-1800 psi) standard setting 80 bar (1150 psi)
(YG3-175)	3XCAR120213	Range 100-200 bar (1450-2900 psi) standard setting 175 bar (2500 psi)
(YG4-250)	3XCAR120214	Range 160-320 bar (2300-4650 psi) standard setting 250 bar (3600 psi)

#### Double stage relief valve (pilot port SAE 8)

(XGD-205-230) 1130040408 Setting 205 and 230 bar (2970 and 3330 psi)

### 2 Inlet valve options (continued) page 15

#### INLET VALVE OPTIONS

TYPE	CODE	DESCRIPTION
F	5KIT420200	Inlet anti-cavitation valve
L	3TAP430402	Hydraulic operated unloader valve

#### Solenoid operated unloader valve

ELN	YEF08002000	Without emergency
ELP	YEF08002002	Push-button emergency
ELV	YEF08002003	Screw type emergency
ELT	YEF08002004	Push and twist type with detent emerg.

### 3 Electric commutator

TYPE	CODE	DESCRIPTION
R2E	0EJ08002048	Electric commutator, ISO4400 connector

For complete available coils list see page 78

### 4 Coils Page 79

TYPE	CODE	DESCRIPTION
12VDC	4SLE001200A	BER type, 12VDC, ISO4400 connector

For complete available coils list see page 78

### 5 Parts \*

CODE	DESCRIPTION
3XTAP838200	SAE16 Plug

NOTE (\*) - Codes are referred to UN-UNF thread.

Configuration with electric commutator

Dimensional data and hydraulic circuit

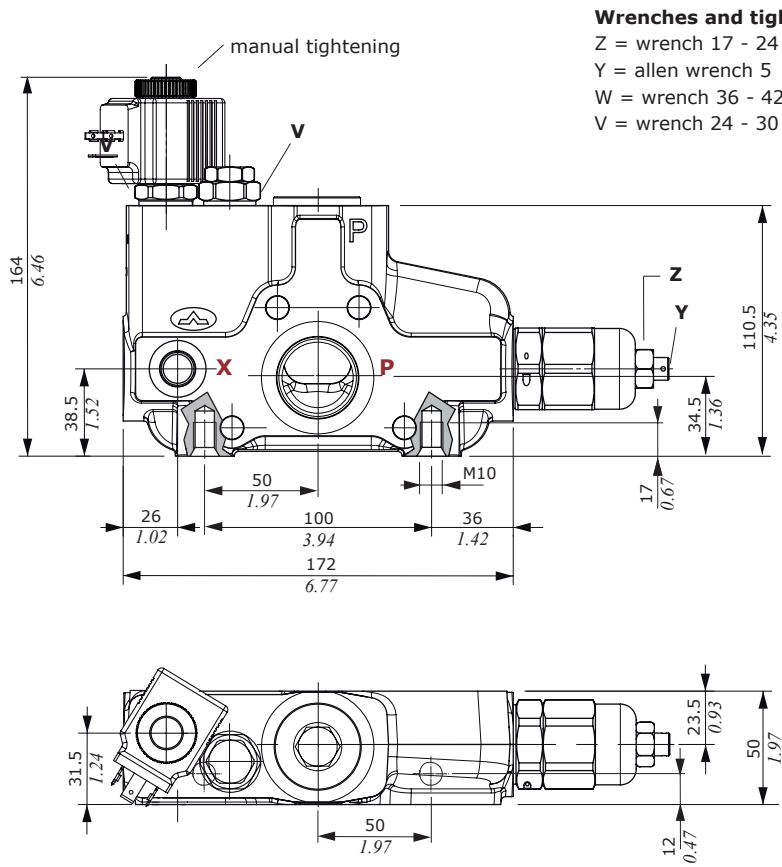

**Wrenches and tightening torques**

- Z = wrench 17 - 24 Nm (17.7 lbf<sub>t</sub>)
- Y = allen wrench 5
- W = wrench 36 - 42 Nm (31 lbf<sub>t</sub>)
- V = wrench 24 - 30 Nm (22.1 lbf<sub>t</sub>)

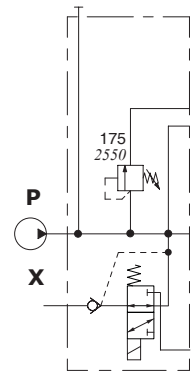

**Electric commutator features**

- Max. pressure . . . . . : 250 bar (3600 psi)
- Nominal flow . . . . . : 25 l/min (6.6 US gpm)
- Internal leakage . . . . . : 40 cm<sup>3</sup>/min @ 210 bar  
(2.44 in<sup>3</sup>/min @ 3050 psi)

For coil **BER** see page 79

## Configuration with flow cut-out

SDS180 / M (LSW - 120) ELNW(NC) - MAN 14 - SAE - 12VDC

1 2 3 1 4

Pressure relief valve setting (bar)

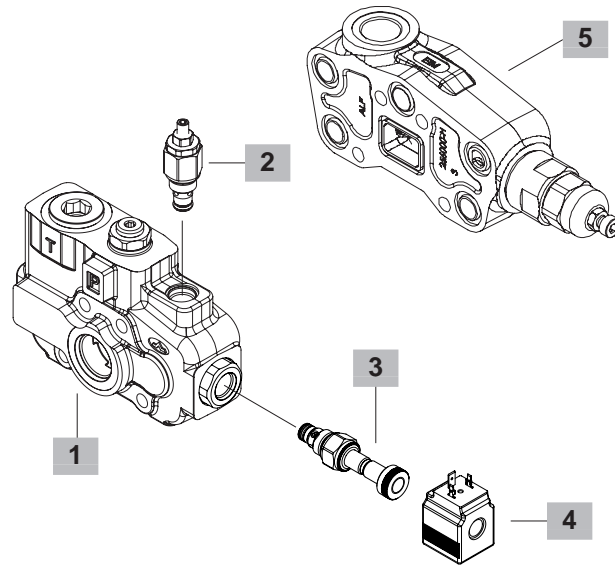

### 1 Inlet cover body \* page 21

CODE: 5FIA118472  
DESCRIPTION: with flow cut-out

### 2 Main relief valve page 21

Standard setting is referred to 10 l/min (2.6 US gpm) flow.

TYPE	CODE	DESCRIPTION
LSW(G2)	5KIT118110	Range 5-50 bar (72-720 psi) standard setting 30 bar (400 psi)
LSW(G3)	5KIT118111	Range 50-220 bar (720-3200 psi) standard setting 150 bar (2150 psi)
LSW(G4)	5KIT118112	Range 180-315 bar (2600-4550 psi) standard setting 250 bar (3600 psi)
SV	XTAP525320	Relief valve blanking plug

### 3 Unloader valve options page 21

TYPE	CODE	DESCRIPTION
ELN(NO)	0EF08002000	Without manual emergency, NO circuit
ELN(NC)	0EF08002001	Without manual emergency, NC circuit
ELT(NO)	0EF08002004	"Push&twist" manual emergency, NO circuit
ELP(NO)	0EF08002002	Push-button manual emergency, NO circuit
ELV(NO)	0EF08002003	Screw type manual emergency, NO circuit

### 4 Coils page 79

TYPE	CODE	DESCRIPTION
12VDC	4SLE001200A	BER type, 12VDC, ISO4400 connector For complete available coils list see page 78

### 5 Intermediate section \* page 62

TYPE	CODE	DESCRIPTION
EIM(XG-220)	618425002	intermediate section with pressure relief valve

NOTE: inlet cover with flow cut-out must be **always** assembled with EIM intermediate section. (see page 62).

NOTE (\*) - Codes are referred to UN-UNF thread.

Dimensional data and hydraulic circuit

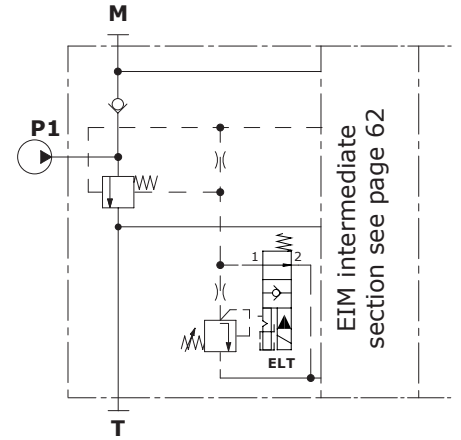
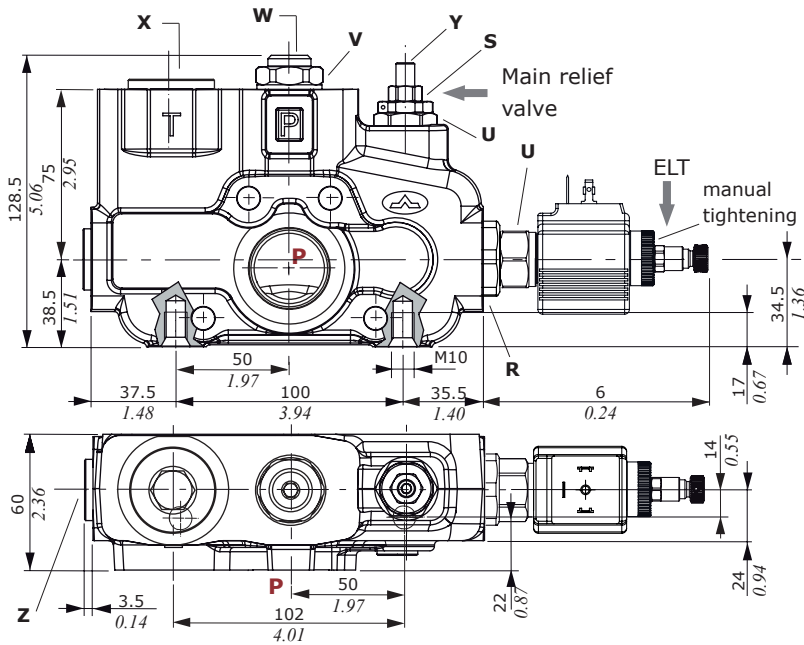

Wrenches and tightening torques

- X = wrench 12 - 42 Nm (31 lbft)
- Y = allen wrench 4
- W = wrench 6 - 24 Nm (17.7 lbft)
- Z = wrench 10 - 24 Nm (17.7 lbft)
- V = wrench 27 - 24 Nm (17.7 lbft)
- U = wrench 24 - 30 Nm (22.1 lbft)
- R = wrench 32 - 42 Nm (31 lbft)
- S = allen wrench 13

Legenda

- ELN: without emergency
- ELP: push button emergency override
- ELV: screw emergency override
- ELT: "push&twist" emergency override

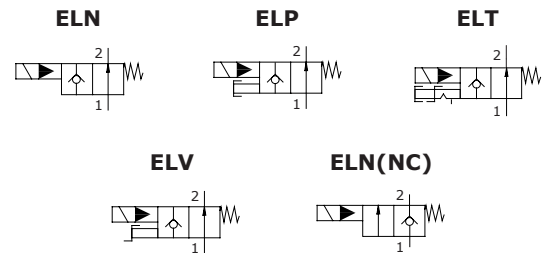

LSW(G2) main relief valve setting range

From 5 to 50 bar (from 72 to 720 psi)

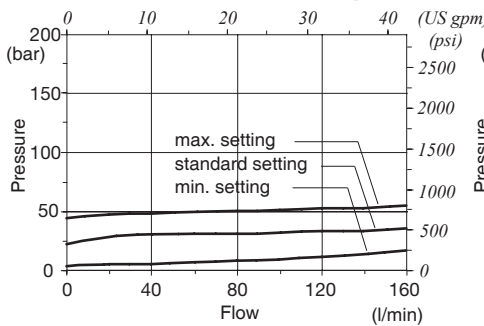

LSW(G3) main relief valve setting range

From 50 to 200 bar (from 720 to 2900 psi)

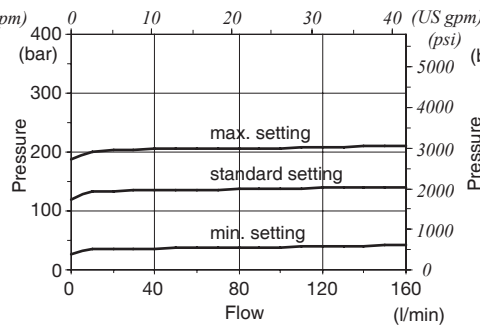

LSW(G4) main relief valve setting range

From 180 to 315 bar (from 2600 to 4550 psi)

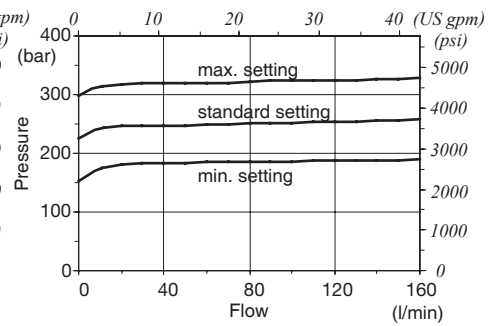

Pressure drop P ⇒ T on flow cut-out

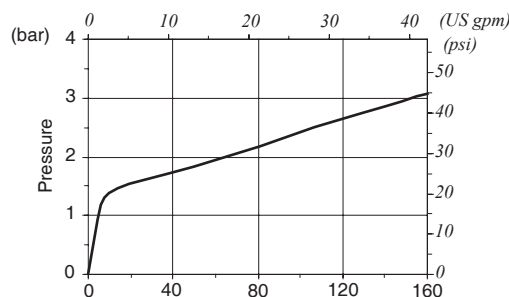

### Configuration with priority valve

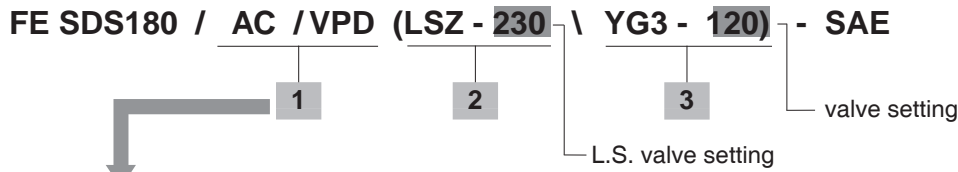

#### Available configurations

- AC: with side inlet, for left inlet (standard) directional valve
- AD: with upper inlet, for left inlet (standard) directional valve
- BC: with side inlet, for right inlet (standard) directional valve
- BD: with upper inlet, for right inlet (standard) directional valve

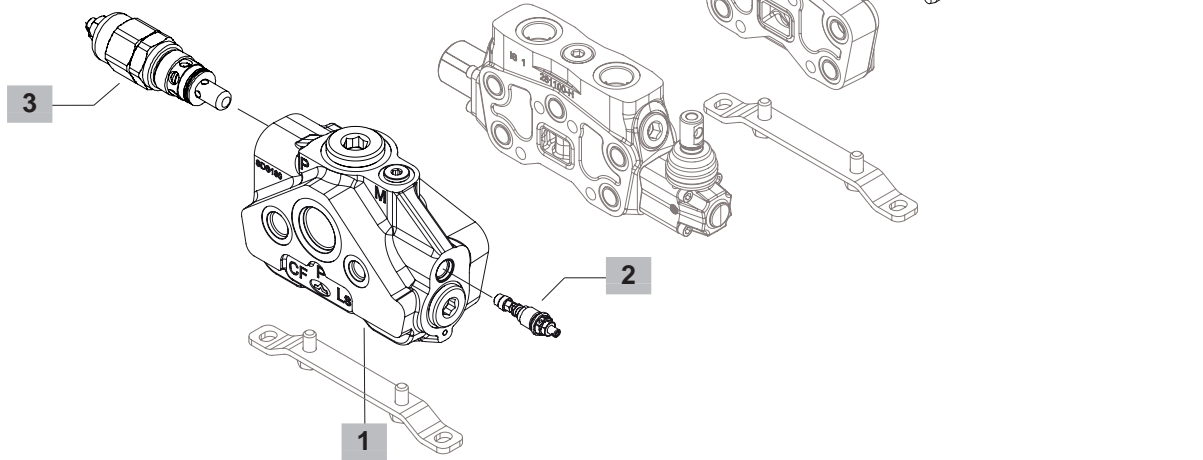

#### 1 Inlet cover body \* page 23

CODE: 5FIA118720  
DESCRIPTION: With priority valve

#### 2 L.S. relief valve options page 23

Standard setting is referred to 10 l/min (2.6 US gpm) flow.

TYPE	CODE	DESCRIPTION
<b>LSD</b>	XCAR126215	With blind nut, range 40-180 bar (580-2600 psi), standard setting 90 bar (1300 psi)
	XCAR126213	As previous, range 180-350 bar (2600-5000 psi) standard setting 180 bar (2600 psi)
<b>LSH</b>	XCAR126216	Arranged for lead sealing, range 40-180 bar (580-2600 psi), standard setting 90 bar (1300 psi)
	XCAR126217	As previous, range 180-350 bar (2600-5000 psi) standard setting 180 bar (2600 psi)
<b>LSZ</b>	XCAR126218	With tamper proof cap, range 6-115 bar (80-1660 psi), standard setting 90 bar (1300 psi)
	XCAR126219	As previous, range 130-350 bar (1900-5000 psi) standard setting 180 bar (2600 psi)
<b>ST</b>	5KIT126210	Relief valve blanking plug

#### 3 Inlet valve options page 13

Standard setting is referred to 10 l/min (2.6 US gpm) flow.

TYPE	CODE	DESCRIPTION
<b>SV</b>	3XTAP535410	Relief valve blanking plug
<b>VMP20/1 pilot operated pressure relief valve X type</b>		
<b>(XG-120)</b>	X007211120	Range 60-315 bar (870-4570 psi) standard setting 120 bar (1750 psi)
<b>(XGN-120)</b>	XCAR120313	As previous without filter
<b>VMD20/1 direct pressure relief valve Y type (standard)</b>		
<b>(YG2-80)</b>	3XCAR120212	Range 63-125 bar (900-1800 psi) standard setting 80 bar (1150 psi)
<b>(YG3-175)</b>	3XCAR120213	Range 100-200 bar (1450-2900 psi) standard setting 175 bar (2500 psi)
<b>(YG4-250)</b>	3XCAR120214	Range 160-320 bar (2300-4650 psi) standard setting 250 bar (3600 psi)
<b>Double stage relief valve (pilot port SAE 8)</b>		
<b>(XGD-207-235)</b>	1130040408	Setting 207 and 235 bar (3000 and 3400 psi)

#### 4 Assembling kit

CODE	DESCRIPTION
<b>5TIR4161</b>	Tie rod kit for 1 working sectional valve
<b>5TIR4162</b>	Tie rod kit for 2 working sectional valve
<b>5TIR4163</b>	Tie rod kit for 3 working sectional valve
<b>5TIR4164</b>	Tie rod kit for 4 working sectional valve
<b>5TIR4165</b>	Tie rod kit for 5 working sectional valve
<b>5TIR4166</b>	Tie rod kit for 6 working sectional valve
<b>5TIR4167</b>	Tie rod kit for 7 working sectional valve
<b>5TIR4168</b>	Tie rod kit for 8 working sectional valve
<b>5TIR4169</b>	Tie rod kit for 9 working sectional valve
<b>5TIR416A</b>	Tie rod kit for 10 working sectional valve

NOTE (\*) - Codes are referred to UN-UNF thread.

Configuration with priority valve

Dimensional data and hydraulic circuit

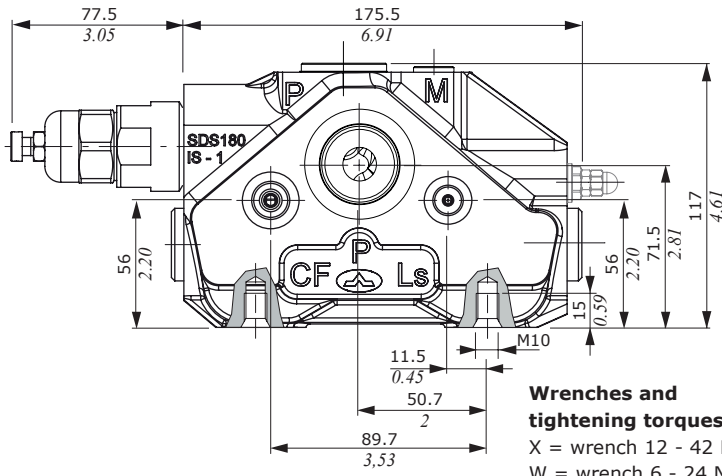

**Wrenches and tightening torques**

- X = wrench 12 - 42 Nm (31 lbf<sub>t</sub>)
- W = wrench 6 - 24 Nm (17.7 lbf<sub>t</sub>)
- A = wrench 10 - 9.8 Nm (7.23 lbf<sub>t</sub>)
- B = wrench 13 - 42 Nm (31 lbf<sub>t</sub>)
- C = wrench 3

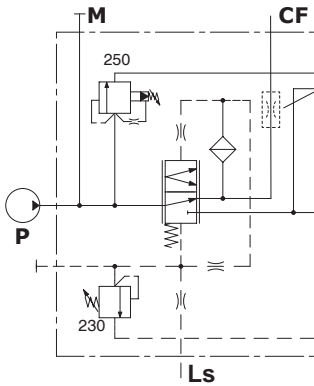
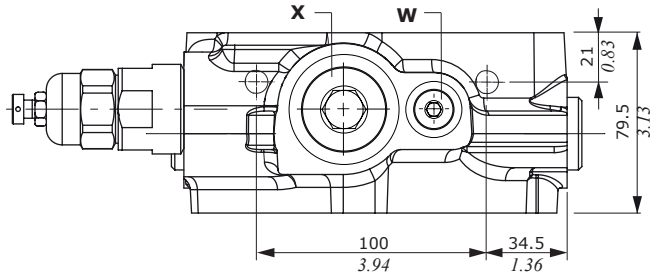

**Load Sensing pressure relief valves**

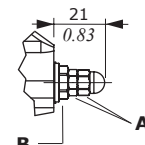

**LSD:** with blind nut

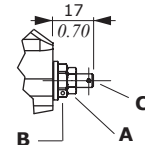

**LSH:** arranged for lead sealing

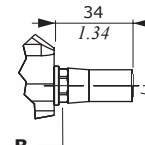

**LSZ:** with tamper proof cap

tamper proof code: 4COP116420

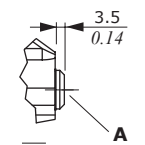

**ST:** valve blanking plug

**Stand-by pressure vs. regulated flow for various values of inlet flow**

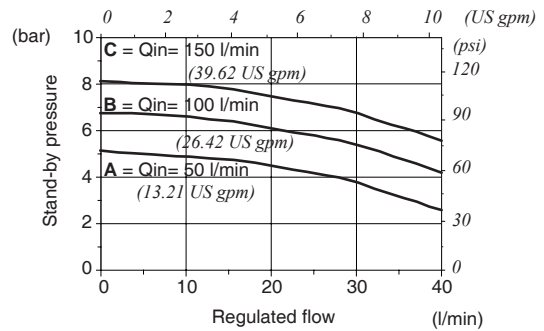

**LSH, LSD valve and LSZ setting range**

From 40 to 180 bar (from 580 to 2600 psi)

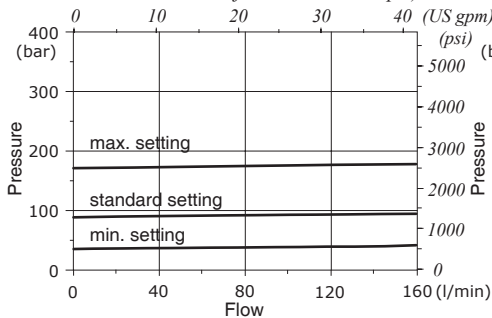

**LSH and LSD valve setting range**

From 180 to 350 bar (from 2600 to 5100 psi)

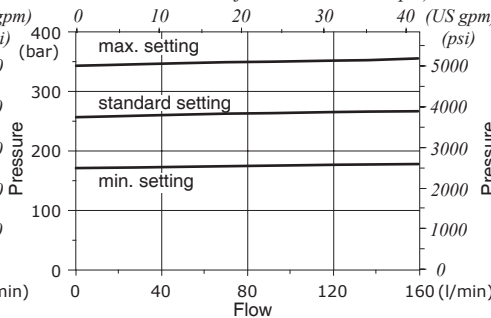

**LSZ valve setting range**

From 180 to 350 bar (from 2600 to 5100 psi)

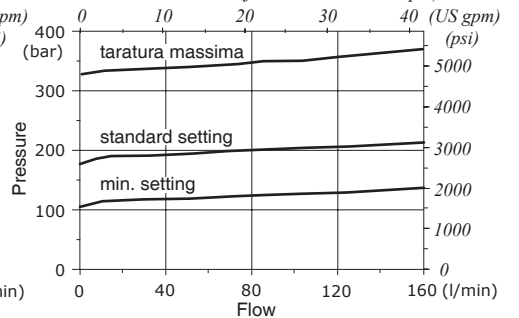

## Configuration with unloader operation spool type

SDS180 / BCHW (LSW - 250) ELN(NO) - 24VDC

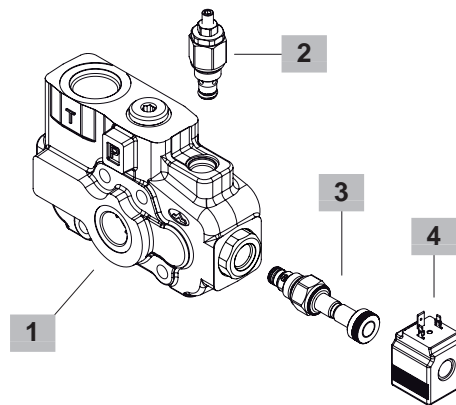
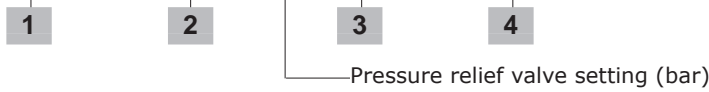

### 1 Inlet cover body \* page 25

CODE: 5FIA118702  
DESCRIPTION: with unloader operation spool type

### 2 Main relief valve page 25

Standard setting is referred to 10 l/min (2.6 US gpm) flow.

TYPE	CODE	DESCRIPTION
<b>LSW(G2)FC07</b>	5KIT118120	Range 5-50 bar (72-720 psi) standard setting 30 bar (400 psi)
<b>LSW(G3)FC07</b>	5KIT118121	Range 50-200 bar (720-3200 psi) standard setting 150 bar (2150 psi)
<b>LSW(G4)FC07</b>	5KIT118122	Range 180-318 bar (2600-4600 psi) standard setting 250 bar (3600 psi)
<b>SV</b>	XTAP525320	Relief valve blanking plug

### 3 Pilot solenoid valve options page 25

TYPE	CODE	DESCRIPTION
<b>ELN(NO)</b>	0EF08002000	Without manual emergency, NO circuit
<b>ELN(NC)</b>	0EF08002001	Without manual emergency, NC circuit
<b>ELT(NO)</b>	0EF08002004	"Push&twist" manual emergency, NO circuit
<b>ELP(NO)</b>	0EF08002002	Push-button manual emergency, NO circuit
<b>ELV(NO)</b>	0EF08002003	Screw type manual emergency, NO circuit

### 4 Coils page 79

TYPE	CODE	DESCRIPTION
<b>24VDC</b>	4SLE002400A	<b>BER</b> type, 24VDC, ISO4400 connector

For complete available coils list see page 78

NOTE (\*) - Codes are referred to **UN-UNF** thread.



Configuration with unloader operation spool type

Dimensional data and hydraulic circuit

**Wrenches and tightening torques**

- X = wrench 8 - 24 Nm (17.7 lbft)
- Y = wrench 10 - 24 Nm (17.7 lbft)
- W = allen wrench 4
- V = wrench 13
- U = wrench 24 - 30 Nm (22.1 lbft)
- R = wrench 32 - 42 Nm (31 lbft)

**Legenda**

- ELN: without emergency
- ELP: push button emergency override
- ELV: screw emergency override
- ELT: "push&twist" emergency override

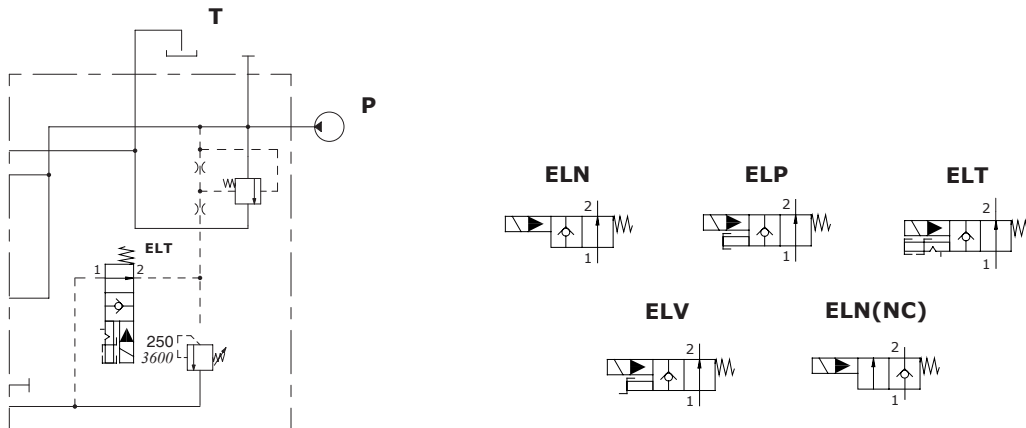
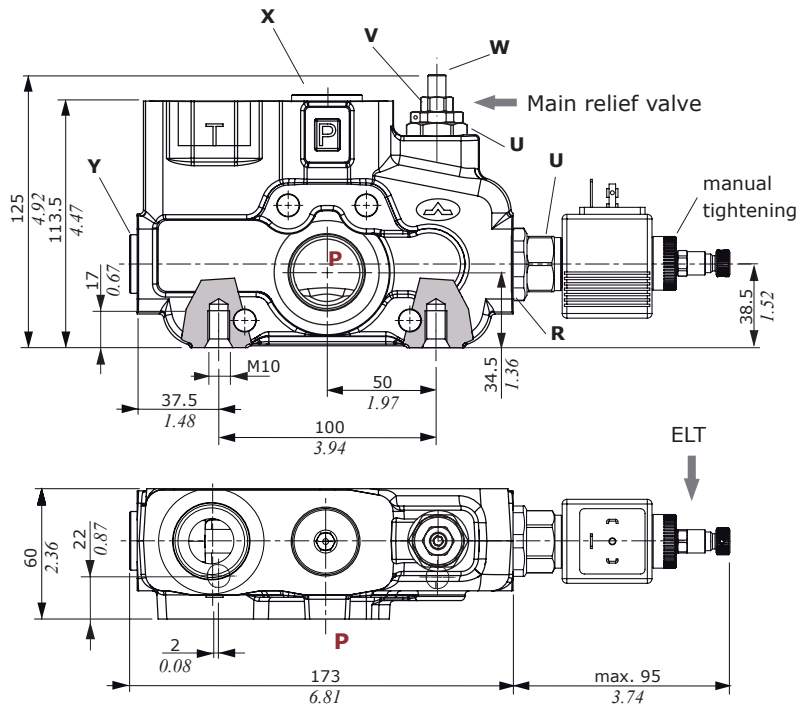

**Pressure drop P ⇒ T  
with unloader operation spool type  
on SDS 180/4**

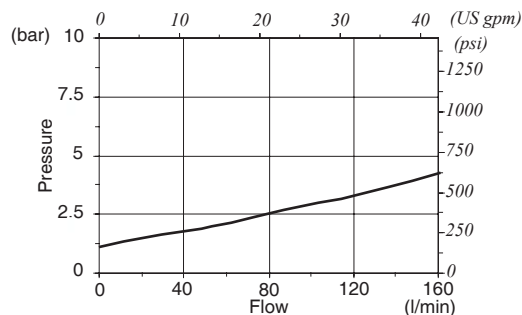

NOTE - For other valve diagrams see page 21.

## Parts ordering codes (mechanical control)

EL SDS180 / **PHT** - 1 8 L . P1 (G3 - **100**) - SAE  
 1 2a 3 4 5a  
 Pressure relief valve setting (bar)

EL SDS180 / **RPHT** - 1 8 L . U (**100**) - SAE  
 1 2a 3 4 5b  
 Pressure relief valve fixed setting (bar)

EL SDS180 / **RPH5LL** - **5HFLL** 8 L . U (**100**) SAE  
 1 2b 3 4 5b  
 Pressure relief valve fixed setting (bar)

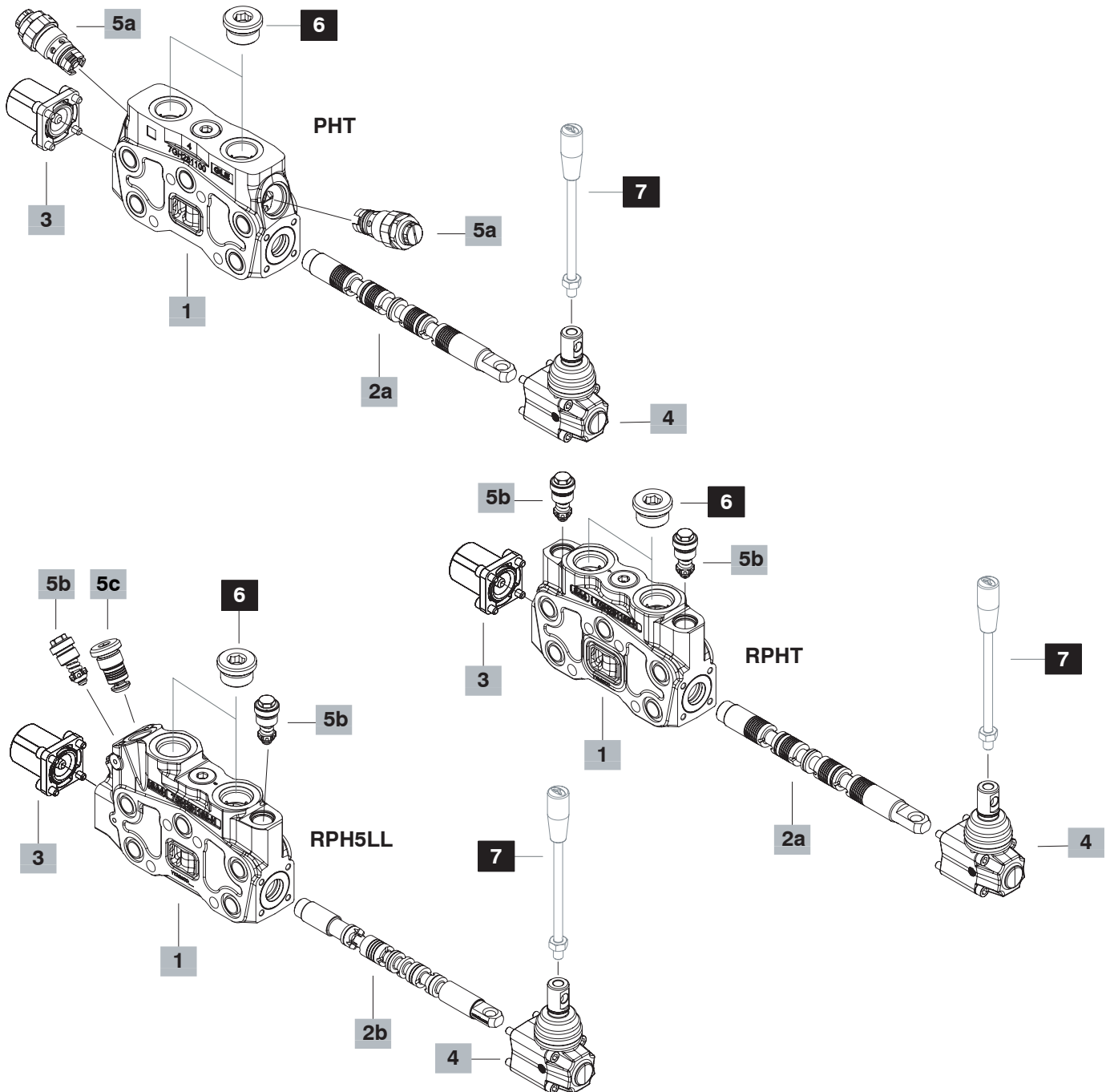

## Parts ordering codes (mechanical control)

**1 Working section kit \* page 30**

TYPE	CODE	DESCRIPTION
<b>PHT</b>	5EL1187080	For parallel circuit
<b>RPHT</b>	5EL1187057	For parallel circuit with upper arrangement for fixed setting port valves
<b>RQHT</b>	5EL1187056	For parallel circuit without upper arrangement for port valves
<b>SP</b>	5EL3187001 5EL1187001A	For tandem circuit As previous, <b>for 8MG..., 8PDG, 8PG, 8EPD, 8EPG spool positioners</b>
<b>S</b>	5EL2167000	For series circuit
<b>S(MG)</b>	5EL3187001A	As previous, <b>for 8MG..., 8PDG, 8PG, 8EPD, 8EPG spool positioners</b>
<b>P5</b>	5EL1187200	For parallel circuit and floating circuit
<b>RPH5</b>	5EL1187250	For parallel circuit with floating circuit with upper arrangement for fixed setting port valves
<b>PES</b>	5EL1167000	For parallel circuit, for valve with series circuit (page 7)
<b>PHT(MG)</b>	5EL1187080D	As PHT, <b>for 8MG..., 8PDG, 8PG, 8EPD, 8EPG spool positioners</b>
<b>RPHT(MG)</b>	5EL1187057D	As previous with upper arrangement for fixed setting port valves
<b>RQHT(MG)</b>	5EL1187056D	As previous without upper arrangement for port valves
<b>PH</b>	5EL1187000	Regenerative control kit, <b>for 8CR, 9BCR-10BCR e 8EI3CR spool positioners</b>
<b>PH(MG)</b>	5EL1187000C	As previous, <b>for 8MG..., 8PDG, 8PG, 8EPD, 8EPG spool positioners</b>
<b>RPHLL</b>	5EL1187054	For parallel circuit with floating circuit with with arrangement for low leak valve <b>for 1TY spool type</b>
<b>RPH5LL</b>	5EL1187058	For parallel circuit with floating circuit with with arrangement for low leak valve <b>for 5HFLL spool type</b>

NOTE - (MG) for dedicated spool positioners, omitted in description

**2a Spools page 34**

TYPE	CODE	DESCRIPTION
<b>1</b>	3CU2510100	Double acting, 3 positions, with A and B closed in neutral position
<b>1(11A)</b>	3CU2510321	As previous, <b>need 11A spool positioner and dedicated working section kit</b>
<b>1CS</b>	3CU2510200	As type 1, sensitive type
<b>1CSG</b>	3CU2510250	Double acting with A and B closed in neutral position, B partially connect to tank in position1, A partially connect to tank in position 2
<b>1CSGH</b>	3CU2510251	As previous, sensitive type
<b>1A</b>	3CU2521100	Double acting, 3 positions, with A open to tank in neutral position
<b>1B</b>	3CU2522100	Double acting, 3 positions, with B open to tank in neutral position
<b>1D</b>	3CU2510210	As type 1, sensitive type for flow up to 100 l/min (26.42 USgpm)

**2a Spools (continued) page 34**

TYPE	CODE	DESCRIPTION
<b>1TX</b>	3CU2510601	Double acting with A and B closed in neutral position, B partially connect to tank in position 1, A partially connect to tank in position 2; <b>needs ..HT section kit</b>
<b>1TYD</b>	3CU2510603	As previous, B with restricted connection to tank; <b>needs ::HT section kit</b>
<b>2</b>	3CU2525100	Double acting, 3 positions, with A and B open to tank in neutral position
<b>2H</b>	3CU2525225	Double acting 3 positions, with A and B partially open to tank in neutral position
<b>3</b>	3CU2531100	Single acting on A, 3 positions, B plugged; requires G3/4 plug
<b>4</b>	3CU2535100	Single acting on B, 3 positions, A plugged; requires G3/4 plug
<b>5</b>	3CU2541200	Double acting spool with A and B closed in neutral position, 4 positions, with spool in, floating 4 <sup>th</sup> position: <b>need dedicated positioner kit 13MD type and working section kit P5 and type</b>
<b>RPH5</b>		
<b>8PF</b>	3CU2561210	Double acting 3 positions, regenerative circuit in 3 <sup>rd</sup> position with spool in: <b>need dedicated positioners kit</b>
<b>8PFG</b>	3CU2561215	Double acting 3 positions, regenerative circuit in 2 <sup>nd</sup> position with spool out: <b>need dedicated positioners kit</b>

**2b Low leak spools\*\* page 34**

TYPE	CODE	DESCRIPTION
<b>1TYALL</b>	3CU2510629-H	Double acting spool, 3 positions, A and B closed in neutral position, A partially connect to tank <b>for RPHLL working section kit</b>
<b>1TYCLL</b>	3CU2510628-H	Double acting spool, 3 positions, A and B closed in neutral position, A partially connect to tank <b>for RPHLL working section kit</b>
<b>1TYMCLL</b>	3CU2510632-H	As 1TYALL, with A connected to tank through the notch <b>for RPHLL working section kit</b>
<b>5HFLL</b>	3CU2541209-H	Double acting spool with A and B closed in neutral position, 4 positions, with spool in, floating 4 <sup>th</sup> position: <b>for RPH5LL working section kit</b>

NOTES (\*) - Codes are referred to **UN-UNF** thread.

(\*\*) For special features of the various spools please contact our Sales Dpt

Parts ordering codes (mechanical control)

**3 "A" side spool positioners (cont.) page 36**

TYPE	CODE	DESCRIPTION
<b>8</b>	5V08110000	With spring return in neutral position
<b>8TL</b>	5V08110310	As type 8, for flexible cable control
<b>8F2</b>	5V08110101	As type 8 with adjustable stroke limiter
<b>11</b>	5V11110000	Detent in positions neutral, 1 and 2
<b>12</b>	5V12110000	Detent in positions 1 and 2
<b>15</b>	5V15110000	2 positions, detent in positions 1 and neutral
<b>16</b>	5V16110000	2 positions, detent in positions 2 and neutral
<b>9BZ</b>	5V09110030	With detent in position 1 and spring return in neutral position
<b>10BZ</b>	5V10110030	With detent in position 2 and spring return in neutral position
<b>11BZ</b>	5V11110030	Detent in positions 1 and 2 and spring return in neutral position
<b>8MG3(NO)<sup>(1)</sup></b>	5V08110050	As type 8, operation with microswitch (NO) in positions 1 and 2
<b>8MG19/29 (NC\NC)<sup>(1)</sup></b>	5V08110080	As type 8, operation with 2 microswitch (NC) in positions 1 and 2
<b>8RMN2</b>	5V08416030	12 VDC with electromagnetic detent
	5V08416040	24 VDC with electromagnetic detent
<b>8KBER</b>	5V08710112	As type 8 and 12 VDC solenoid lock device
	5V08710124	As previous, 24 VDC
<b>8PDG<sup>(1)</sup></b>	5V08110710	ON/OFF pneumatic waterproof kit
<b>8PG<sup>(1)</sup></b>	5V08110708	ON/OFF pneumatic kit
<b>8EPDG3<sup>(1)</sup></b>	5V08110740	12 VDC ON/OFF pneumatic waterproof kit
	5V08110738	24 VDC ON/OFF pneumatic waterproof kit
<b>8EPG3</b>	5V08110725	12 VDC ON/OFF electro-pneumatic kit
	5V08110726	24 VDC ON/OFF electro-pneumatic kit
<b>8EI3</b>	5V08110320	12 VDC ON/OFF electro-hydraulic kit
	5V08110321	24 VDC ON/OFF electro-hydraulic kit
<b>8IZ</b>	5V08110801	Unilateral hydraulic proportional spool control kit
<b>11A<sup>(2)</sup></b>	5V11510110	With detent in positions 1 and 2, automatic release in neutral position
<b>13MD</b>	5V13416010	4 positions, detent in 4 <sup>th</sup> position with spring return in neutral position with detent pull type. <b>Needs spool type 5</b>

Positioner kit for **8PF** and **8PFG** regenerative spools:

Overall dimensions are the same ones as those of standard controls listed above.

<b>8CR</b>	5V08110020	With spring return in neutral position
<b>9BCR</b>	5V09110020	With detent in position 1 and spring return in neutral position
<b>8PGCR<sup>(1)</sup></b>	5V08110706	ON/OFF pneumatic kit
<b>8EPG3CR<sup>(1)</sup></b>	5V08110727	12 VDC electro-pneumatic kit ON/OFF
	5V08110728	24 VDC electro-pneumatic kit ON/OFF
<b>8EI3CR</b>	5V08110357	12 VDC electro-hydraulic kit ON/OFF
	5V08110353	24 VDC electro-hydraulic kit ON/OFF

**4 "B" side options page 46**

TYPE	CODE	DESCRIPTION
<b>L</b>	5LEV110000	Standard lever box
<b>LF1</b>	5LEV110101	Lever box with spool stroke limiter in position 1
<b>LB</b>	5LEV310000	Steel lever kit
<b>LCB</b>	5CLO216100	Joystick lever for 2 sections operation
<b>LCE</b>	5CLO216050	As previous with bronze support
<b>SL</b>	--	Without lever box
<b>SLP</b>	5COP110000	Without lever box, with dust-proof plate
<b>TQ</b>	5TEL110110	Flexible cable connection; for CD cables

**5a Adjustable port valves page 53**

Valves standard setting is referred to 10 l/min (2.64 USgpm) flow.

TYPE	CODE	DESCRIPTION
-	XTAP530361	Valve blanking plug (omitted in description)
<b>C</b>	3XCAR416100	Anti-cavitation valve
<b>Anti-shock valve</b>		
<b>P(G2)</b>	XCAR216115	Range 50-120 bar (725-1750 psi) standard setting 63 bar (900 psi)
<b>P(G3)</b>	XCAR216116	Range 100-250 bar (1450-3600 psi) standard setting 100 bar (1450 psi)
<b>P(G4)</b>	XCAR216117	Range 160-315 bar (2300-4600 psi) standard setting 200 bar (2900 psi)
<b>Pilot hydraulic unloader valve</b>		
<b>PX</b>	XCAR416301	Pilot hydraulic unloader valve
<b>Anti-shock and anti-cavitation valve</b>		
<b>U(G2)</b>	X011411099	Range 35-90 bar (510 -1300 psi) standard setting 60 bar (870 psi)
<b>U(G3)</b>	X011411100	Range 100-250 bar (1450-3600 psi) standard setting 100 bar (1800 psi)
<b>U(G4)</b>	X011411101	Range 180-350 bar (2600-5100 psi) standard setting 200 bar (2900 psi)
<b>Pilot operated anti-shock and anti-cavitation valve</b>		
<b>UXW(G)</b>	X01141B160	Range 63-315 bar (900-4600 psi) standard setting 160 bar (2300 psi)

NOTE <sup>(1)</sup> - Needs dedicated working section kit **..(MG)** type.

<sup>(2)</sup> - Needs dedicated **PHT** working section kit and **1(11A)** spool type.

## Parts ordering codes (mechanical control)

**5b Fixed setting port valves page 57****For RPH.. and RQH.. working section kit**

TYPE	CODE	DESCRIPTION
UT	XTAP522441	Valve blanking plug
C	5KIT410000	Anticavitation valve

**Fixed setting antishock and anticavitation valves:**

setting is referred to 10 l/min (2.6 US gpm)

TYPE	CODE	DESCRIPTION
U025	5KIT330025	Setting 25 bar (363 psi)
U030	5KIT330030	Setting 30 bar (435 psi)
U040	5KIT330040	Setting 40 bar (580 psi)
U050	5KIT330050	Setting 50 bar (725 psi)
U063	5KIT330063	Setting 63 bar (914 psi)
U080	5KIT330080	Setting 80 bar (1150 psi)
U100	5KIT330100	Setting 100 bar (1450 psi)
U110	5KIT330110	Setting 110 bar (1590 psi)
U125	5KIT330125	Setting 125 bar (1800 psi)
U140	5KIT330140	Setting 140 bar (2050 psi)
U150	5KIT330150	Setting 150 bar (2150 psi)
U160	5KIT330160	Setting 160 bar (2300 psi)
U175	5KIT330175	Setting 175 bar (2550 psi)
U190	5KIT330190	Setting 190 bar (2750 psi)
U200	5KIT330200	Setting 200 bar (2900 psi)
U210	5KIT330210	Setting 210 bar (3050 psi)
U220	5KIT330220	Setting 220 bar (3190 psi)
U230	5KIT330230	Setting 230 bar (3350 psi)
U240	5KIT330240	Setting 240 bar (3500 psi)
U250	5KIT330250	Setting 250 bar (3600 psi)
U260	5KIT330260	Setting 260 bar (3750 psi)
U270	5KIT330270	Setting 270 bar (3900 psi)
U280	5KIT330280	Setting 280 bar (4050 psi)
U290	5KIT330290	Setting 290 bar (4200 psi)
U300	5KIT330300	Setting 300 bar (4350 psi)
U310	5KIT330310	Setting 310 bar (4500 psi)

**5c Low leak valve page 57****For RPHLL and RQH5LL working section kit:**

TYPE	CODE	DESCRIPTION
LL	5KIT918002	Low leak valve

**6 Port plugs \***

CODE	DESCRIPTION
3XTAP832200	SAE12 Plug

**7 Optional handlevers**

TYPE	CODE	DESCRIPTION
AL01/M10x200	170012020	For L lever box, L= 200 mm (7.87 in)
AL08/M12x250	170013125	For LCB joystick, L= 250 mm (9.84 in)

NOTE (\*) – Codes are referred to **UN-UNF** thread.

## Parts ordering codes (proportional hydraulic control)

EL SDS180 / PHT - 1IM 8IMOH . U1 (G3 - 100)

1      2a      3      4a

Pressure relief valve setting (bar)

EL SDS180 / RPHT - 1IM 8IMOH . U (100)

1      2a      3      4b

Pressure relief valve fixed setting (bar)

EL SDS180 / RPH5LL - 5HFLL 8IMOH . U (100)

1      2b      3      4b

Pressure relief valve fixed setting (bar)

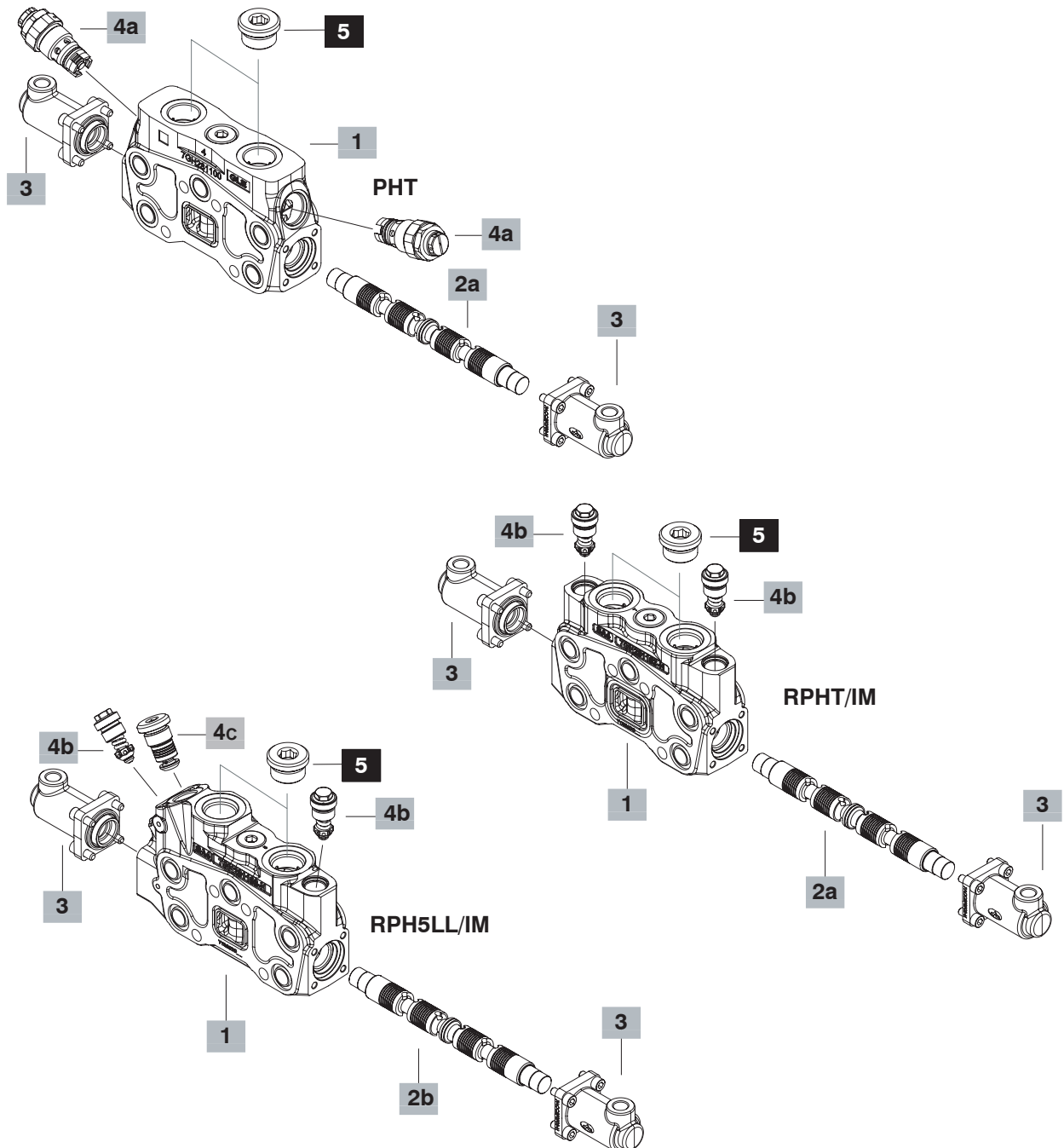

## Parts ordering codes (proportional hydraulic control)

1 Working section kit * page 32		
TYPE	CODE	DESCRIPTION
<b>PHT(IM)</b>	5EL1187080C	For parallel circuit with arrangement for port valves
<b>RPHT(IM)</b>	5EL1187057A	For parallel circuit with upper arrangement for fixed setting port valves
<b>RQHT(IM)</b>	5EL1187056A	As previous without upper arrangement for port valves
<b>P5(IM)</b>	5EL1187205A	As previous for floating circuit: <b>need 5IMP spool type and 13IMP complete control</b>
<b>SP(IM)</b>	5EL3187001B	For tandem circuit
<b>SP5(IM)</b>	5EL3187202	As previous for floating circuit
<b>RP5(IM)</b>	5EL1187250A	For parallel circuit with floating circuit with upper arrangement for fixed setting port valves: <b>need 5IMP(13IMP) spool type and 13IMP complete control</b>
<b>RPHSP(IM)</b>	5EL3187059A	For tandem circuit with upper arrangement for fixed setting port valves
<b>RQHSP(IM)</b>	5EL3187052A	For tandem circuit without arrangement for port valves
<b>RPHSP5(IM)</b>	5EL3187250A	For tandem circuit with floating circuit with upper arrangement for fixed setting port valves
<b>RPHLL(IM)</b>	5EL1187054A	For parallel circuit and floating circuit with arrangement for load leak valve <b>need 1TYMLLIM spool type and 8IMOH control type</b>
<b>RP5LL(IM)</b>	5EL1187058A	For parallel circuit with arrangement for load leak valve <b>need 5HFLIM spool type and 13IMOPHCR control type</b>

NOTE – (IM) for proportional hydraulic control, omitted in description

2a Spools page 34		
TYPE	CODE	DESCRIPTION
<b>1IM</b>	3CU2510420	Double acting with A and B closed in neutral position
<b>1IMDA</b>	3CU2510490	As type 1IM with descent control and load check valve without power supply on port A: <b>need control type 8IMD</b>
<b>1AIM</b>	3CU2522420	Double acting with A open to tank in neutral position
<b>1BIM</b>	3CU2522420	Double acting with B open to tank in neutral position
<b>2HIM</b>	3CU2525425	Double acting with A and B partially connect to tank in neutral position
<b>2IM</b>	3CU2525420	Double acting with A and B connect to tank in neutral position
<b>3IM</b>	3CU2535420	Single acting on A, B plugged
<b>4IM</b>	3CU2535420	Single acting on B; A plugged
<b>5IMP(13IMP)</b>	3CU2542430	Double acting spool with A and B closed in neutral position, spool out floating 4 <sup>th</sup> position: <b>need working section P5(IM) and control type 13 IMP</b>
<b>1IM(8IMSP)</b>	3CU2510491	As type 1IM: <b>need control type 8IMSPSL</b>

2b Low leak spools page 34		
<b>For RPHLL(IM) and RQ5LL(IM) working section kit:</b>		
TYPE	CODE	DESCRIPTION
<b>1TYMLLIM</b>	3CU2510633-H	Double acting with A and B closed in neutral position <b>need RPHLL(IM) working section and 8IMOH control type</b>
<b>5HFLIM</b>	3CU2541210-H	Double acting spool with A and B closed in neutral position <b>need RPH5LL(IM) working section and 13IMOPHCR control type</b>

3 Complete controls * page 49		
<b>Proportional Hydraulic control</b>		
TYPE	CODE	DESCRIPTION
<b>8IMD</b>	5IDR218700-H	Range 5.8-19 bar (84-270 psi): <b>for 1IMDA spool type</b>
<b>8IMOHF3</b>	5IDR216711-H	With screws spool stroke adjusting. Range 5.8-19 bar (84-270 psi)
<b>8IMOHSPSL</b>	5IDR218010-H	With spool position sensor execution. Range 0.8-4.2 bar (11-60 psi): <b>need 1IM(8IMSP) spool type</b>
<b>8IMOH</b>	5IDR216702-H	Range 5-20 bar (72-290 psi)
<b>13IMPOH</b>	5IDR216714	For floating circuit. Range 5.8-14 bar (84-270 psi): <b>need P5(IM) working section and 5IMP spool type</b>
<b>13IMOPHCR</b>	5IDR218350-H	Steel control kit for floating circuit. Range 3.5-18 bar (51-261 psi): <b>need RPH5LL(IM) working section and 5HFLIM spool type</b>

4a Adjustable port valves page 53	
See page 28.	

4b Fixed setting port valves page 57	
See page 29.	

4c Low leak valve page 57		
TYPE	CODE	DESCRIPTION
<b>LL</b>	5KIT918002	Low leak valve

5 Port plugs *	
CODE	DESCRIPTION
3XTAP832200	SAE12 Plug

NOTE (\*) – Codes are referred to UN-UNF thread.

Dimensional data and hydraulic circuit

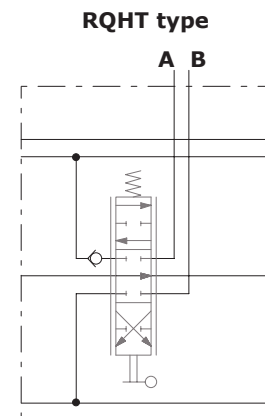
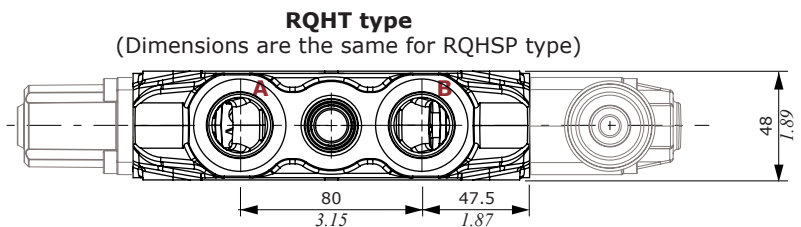
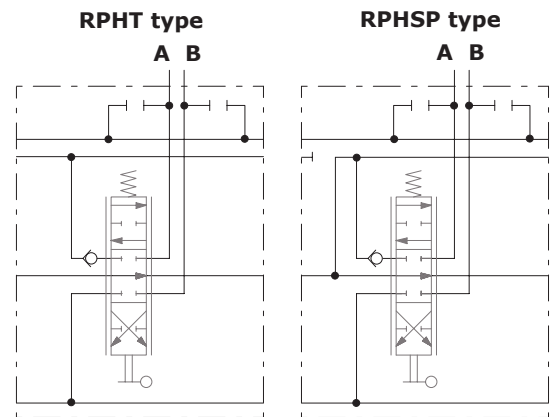
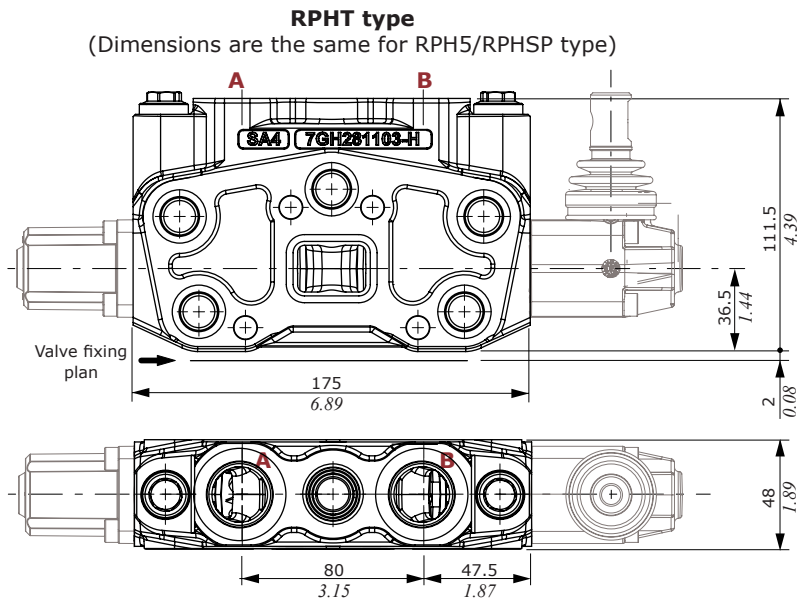
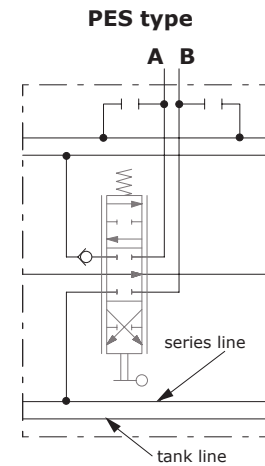
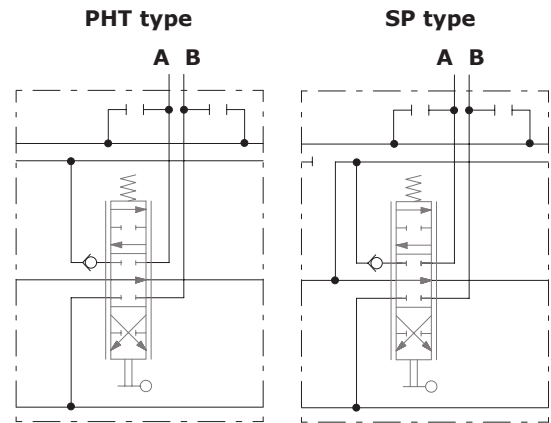
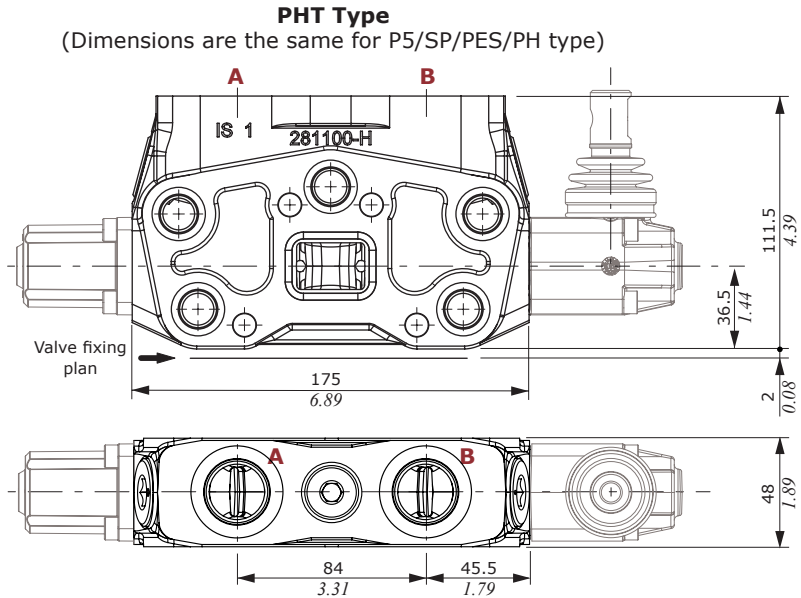



Dimensional data and hydraulic circuit

**RPH5LL type**  
(Dimensions are the same for RPHLL type)

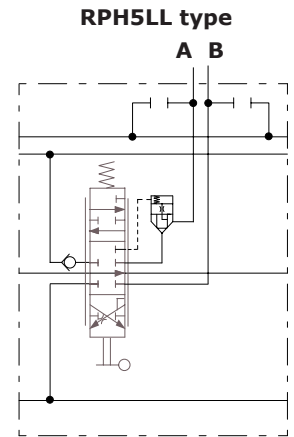
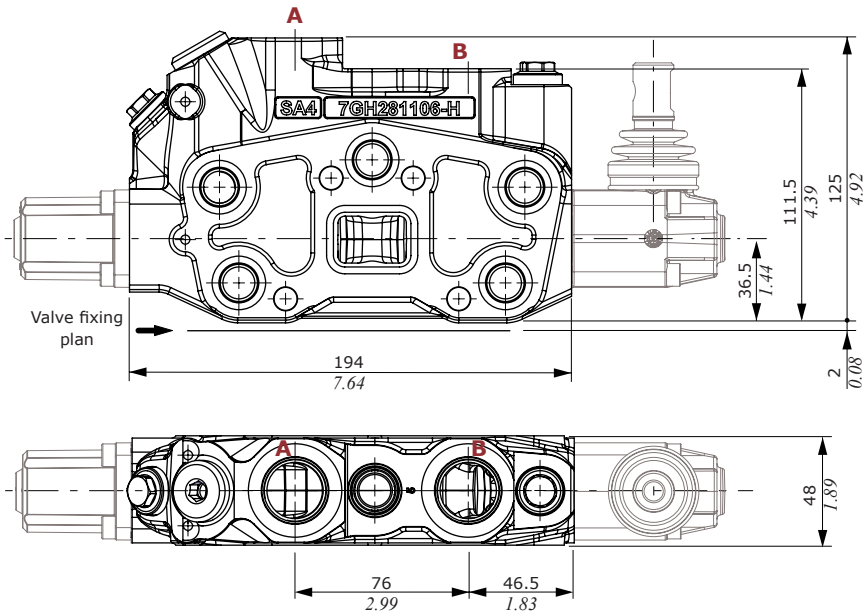

**S type**

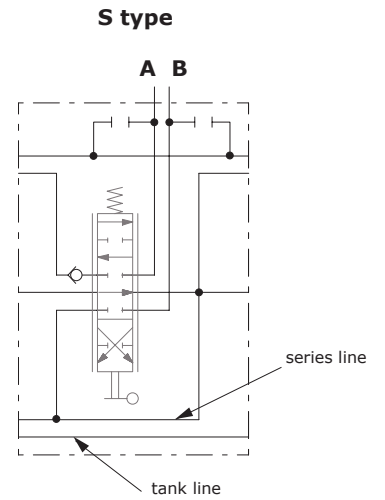
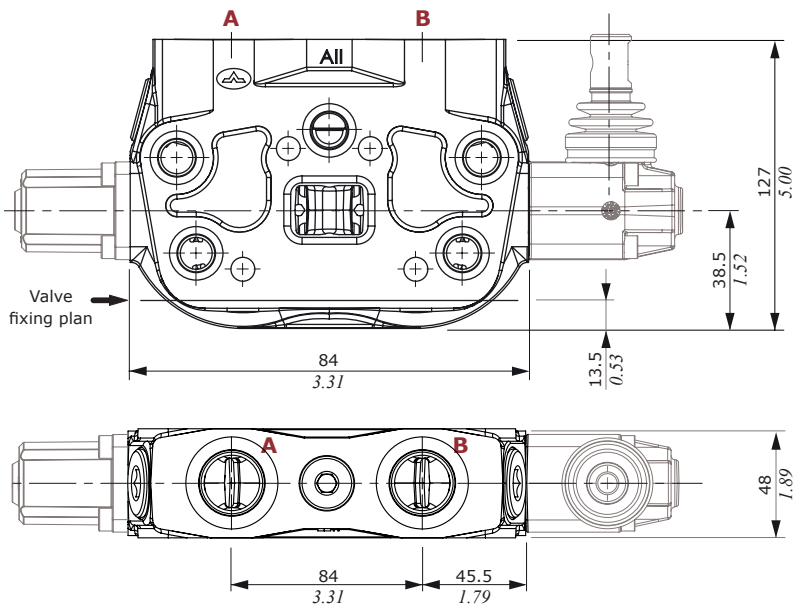

Spools

**1 (1D/1CS/1[11A]/1IM) spool type**

Double acting, 3 positions, with A and B closed in neutral position

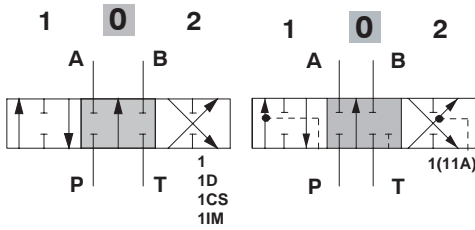

**Spool stroke**

position 1: + 7 mm (+ 0.28 in)  
position 2: - 7 mm (- 0.28 in)

**Spool metering Type 1**

$Q_{in} = 160 \text{ l/min} / (42 \text{ US gpm})$   
 $P_{(on ports)} = 100 \text{ bar} / (1450 \text{ psi})$

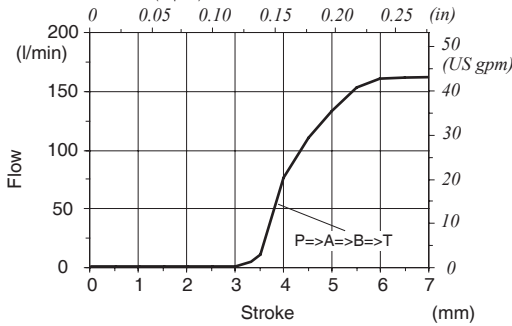

**2 (2IM) spool type**

Double acting, 3 positions, with A and B open to tank in neutral position

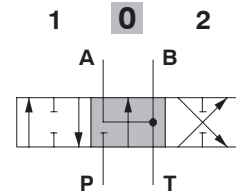

**Spool stroke**

position 1: + 7 mm (+ 0.28 in)  
position 2: - 7 mm (- 0.28 in)

**1A (1AIM) spool type**

Double acting, 3 positions, with A open to tank in neutral position

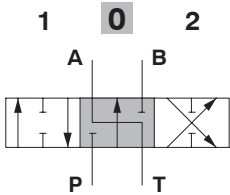

**Spool stroke**

position 1: + 7 mm (+ 0.28 in)  
position 2: - 7 mm (- 0.28 in)

**1B (1BIM) spool type**

Double acting, 3 positions, with B open to tank in neutral position

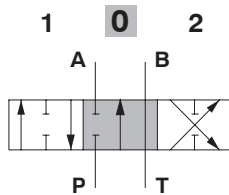

**Spool stroke**

position 1: + 7 mm (+ 0.28 in)  
position 2: - 7 mm (- 0.28 in)

**2HIM spool type**

Double acting, 3 positions, with A and B partially open to tank in neutral position

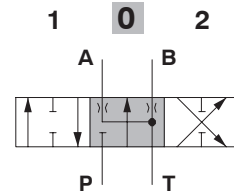

**Spool stroke**

position 1: + 7 mm (+ 0.28 in)  
position 2: - 7 mm (- 0.28 in)

**3 (3IM) spool type**

Single acting on A, 3 positions, B plugged; requires G3/4 plug

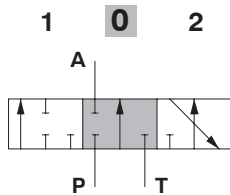

**Spool stroke**

position 1: + 7 mm (+ 0.28 in)  
position 2: - 7 mm (- 0.28 in)

**4 (4IM) spool type**

Single acting on B, 3 positions, A plugged; requires G3/4 plug

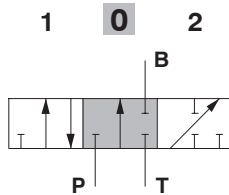

**Spool stroke**

position 1: + 7 mm (+ 0.28 in)  
position 2: - 7 mm (- 0.28 in)

**SPFG spool type**

Double acting, 3 positions, regenerative circuit in 2<sup>nd</sup> position (pos.1) with spool out

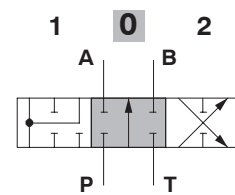

**Spool stroke**

position 1: + 5.7 mm (+ 0.22 in)  
position 2: - 5.7 mm (- 0.22 in)

**1CSG (1CSGH) spool type**

Double acting with A and B closed in neutral position, B partially connect to tank in pos. 1, A partially connect to tank in pos. 2

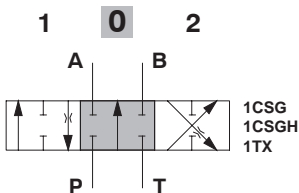

**Spool stroke**

position 1: + 7 mm (+ 0.28 in)  
position 2: - 7 mm (- 0.28 in)

**1TX (1TYD) spool type**

Double acting with A and B closed in neutral position partially connect to tank

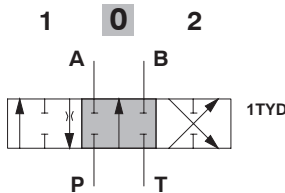

**1IMDA spool type**

Double acting with A and B closed in neutral position, descent control and load check valve without power supply on port A

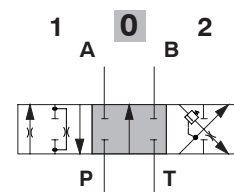

**Spool stroke**

position 1: + 7 mm (+ 0.28 in)  
position 2: - 7 mm (- 0.28 in)

**5 (5IMP) and 5HFL spool type**

Double acting spool with A and B closed in neutral position, 4 positions, with spool in, floating 4<sup>th</sup> position (pos.3)

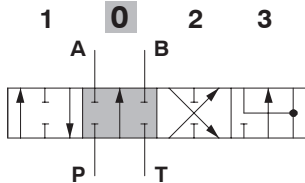

**Type 5 (5IMP) Spool stroke**  
 position 1: + 6 mm (+ 0.24 in)  
 position 2: - 6 mm (- 0.24 in)  
 position 3: - 12 mm (- 0.47 in)

**Spool metering type 5**

$Q_{in} = 160 \text{ l/min} / (42 \text{ US gpm})$   
 $P_{(on ports)} = 100 \text{ bar} / (1450 \text{ psi})$

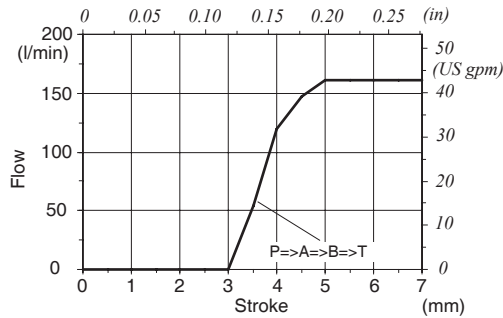

**Spool pressure drop in position 3 - type 5**

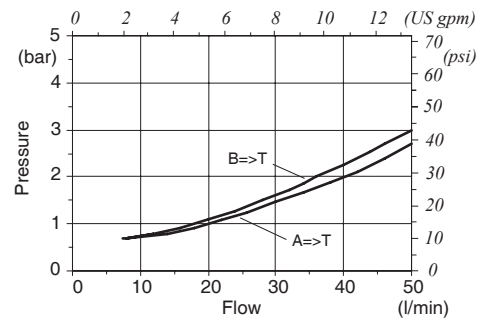

**8PF spool type**

Double acting, 3 positions, regenerative circuit in 3<sup>rd</sup> position (pos. 2) with spool in

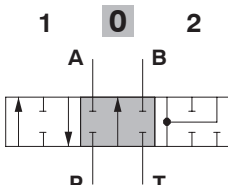

**Spool stroke**  
 position 1: + 5.7 mm (+ 0.22 in)  
 position 2: - 5.7 mm (- 0.22 in)

**Spool metering type 8PF**

$Q_{in} = 160 \text{ l/min} / (42 \text{ US gpm})$   
 $P_{(on ports)} = 100 \text{ bar} / (1450 \text{ psi})$

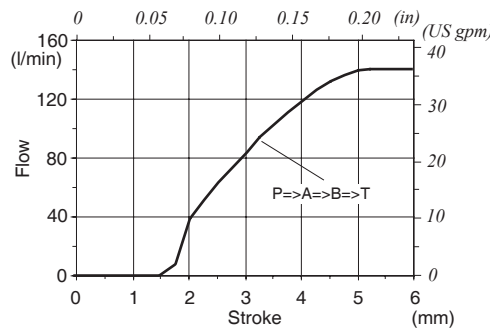

**Pressure drop**

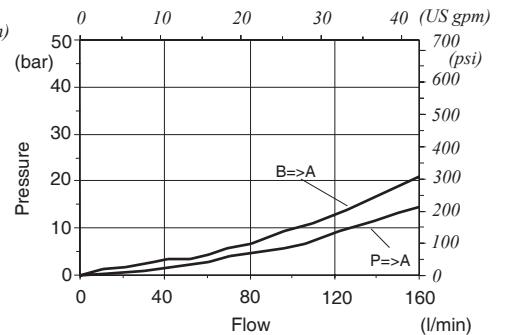

**Low leak spools**

**1TYALL-1TYCLL-1TYMLLIM spool type**

Double acting, 3 positions, with A and B closed in neutral position, A partially connect to tank

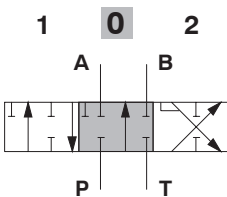

**Spool stroke**  
 position 1: + 7 mm (+ 0.28 in)  
 position 2: - 7 mm (- 0.28 in)

**1TYMCLL spool type**

Double acting, 3 positions, with A and B closed in neutral position, with A connected to tank through the notch

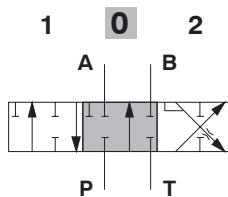

**Spool stroke**  
 position 1: + 7 mm (+ 0.28 in)  
 position 2: - 7 mm (- 0.28 in)

**5HFL-5HFLIM spool type**

Double acting spool with A and B closed in neutral position, 4 positions, with spool in, floating 4<sup>th</sup> position (pos.3)

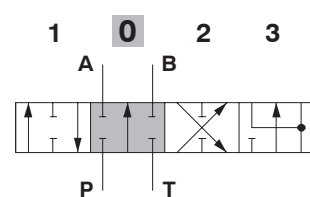

**Spool stroke**  
 position 1: + 6.5 mm (+ 0.25 in)  
 position 2: - 6.5 mm (- 0.25 in)  
 position 3: - 12.5 mm (- 0.49 in)

"A" side spool positioners

With spring return

8 type

It's supplied with standard spring D type (see force-stroke diagram) and available with lighter spring C type (8MC code: 5V08210000).

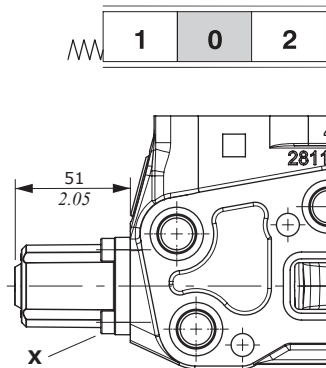

**Wrenches and tightening torques**  
X = wrench 5 - 9.8 Nm (7.23 lbf)

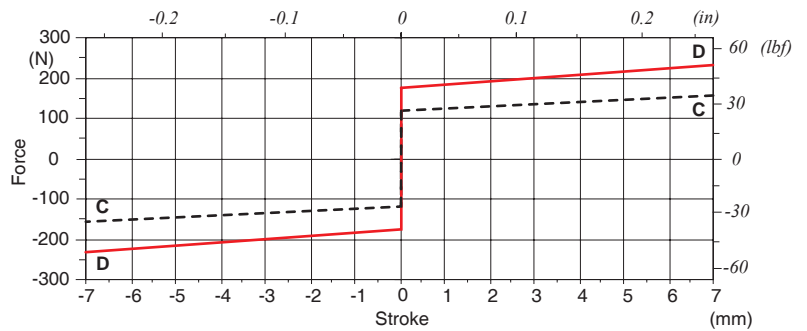

8TL type

As 8 type, for flexible cable control.

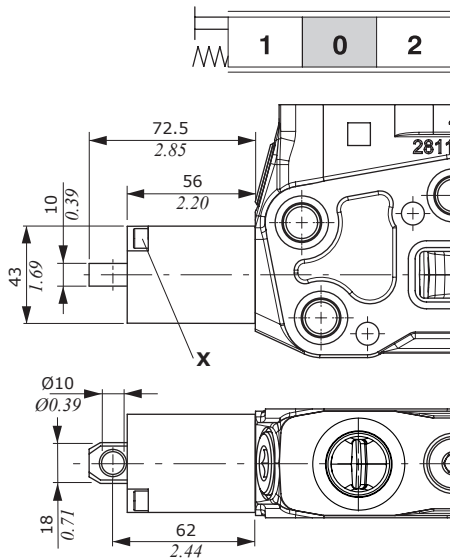

**Wrenches and tightening torques**  
X = wrench 5 - 9.8 Nm (7.23 lbf)

8F2 type

With spool stroke adjustment in position 2 (P ⇒ B).

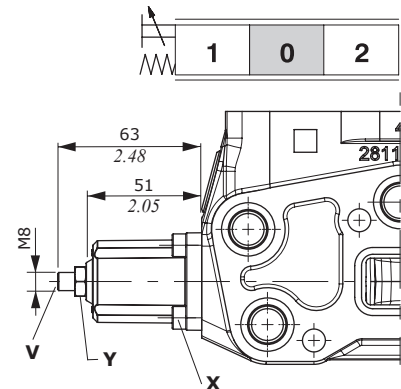

**Wrenches and tightening torques**  
X = wrench 5 - 9.8 Nm (7.23 lbf)  
Y = wrench 13 - 24 Nm (17.7 lbf)  
Z = allen wrench 4

With detent

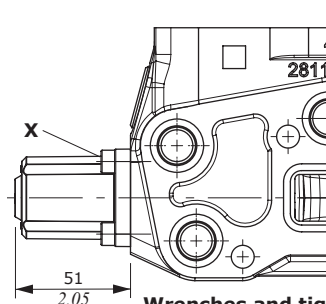

**Wrenches and tightening torques**  
X = wrench 5 - 9.8 Nm (7.23 lbf)

**11 type**  
detent in positions neutral, 1 and 2



**15 type**  
2 positions, detent in positions 1 and neutral

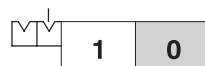

**12 type**  
detent in positions 1 and 2



**16 type**  
2 positions, detent in positions 2 and neutral



Features

Detent and release force ..... : 280 N (63 lbf) ±10%

"A" side spool positioners

With detent and spring return to neutral position from either directions

**9BZ type**  
detent in position 1 (curve A)



**10BZ type**  
detent in position 2 (curve B)



**11BZ type**  
detent in position 1 and 2 (curves A and B)

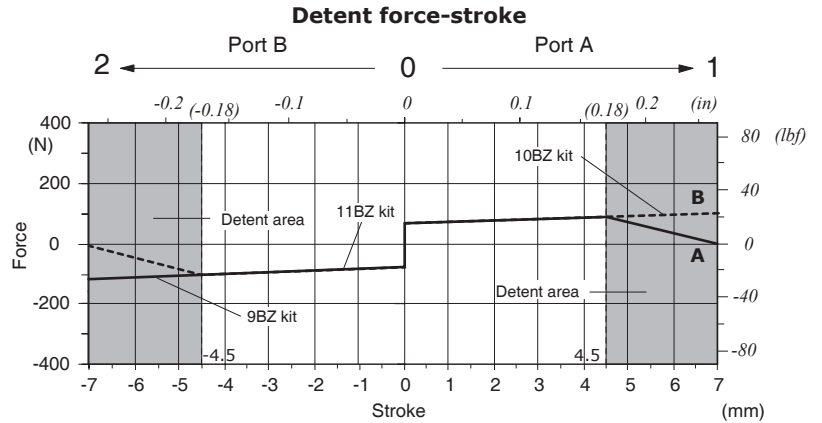
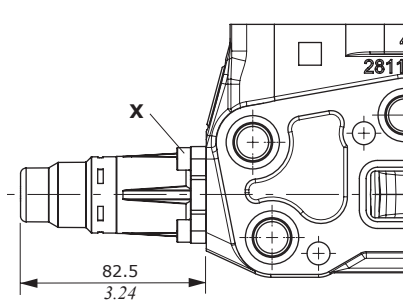
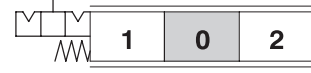

**Position 1** - Detent force: 130 N (29.2 lbf) ± 10% / Release force: 215 N (48.3 lbf) ± 10%  
**Position 2** - Detent force: 145 N (32.6 lbf) ± 10% / Release force: 300 N (67.4 lbf) ± 10%

**Wrenches and tightening torques**  
 X = wrench 4 - 6.6 Nm (4.87 lbf)

**Solenoid lock device 8KBER type**

With spring return and spool electromechanical lock in neutral position; when coil is fed the spool can be moved. When combined with the UXV and PX valves, is mounted roated 180° (configuration: **8KBER180**). it's possible to obtain further configurations with several "A" side spool positioners: contact Sales Dept.

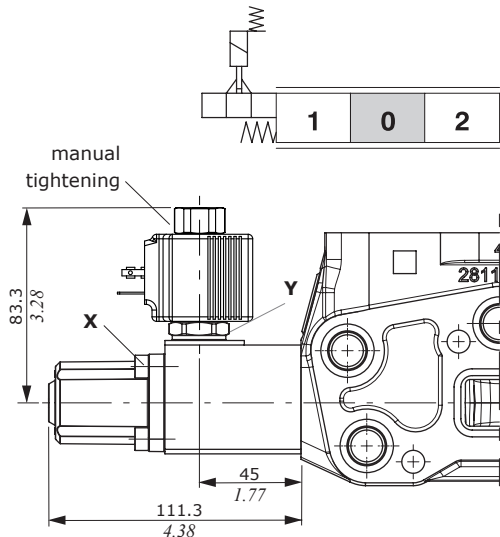

**Wrenches and tightening torques**  
 X = wrench 5 - 9.8 Nm (7.23 lbf)  
 Y = wrench 24 - 24 Nm (17.7 lbf)

**Features**  
 For coil **BER** and mating connectors see page 76

"A" side spool positioners

With microswitch

8MG3 type

With spring return in neutral position and microswitch operated in both directions. Also available **8MG1** (microswitch operated in position 1) and **8MG2** (microswitch operated in position 2) configurations; dimension are the same of **8MG3** configuration. It requires **MG** working section kit. See page 27.

Wrenches and tightening torques

X = wrench 5 - 9.8 Nm (7.23 lbft)  
Y = wrench 22 - 24 Nm (17.7 lbft)

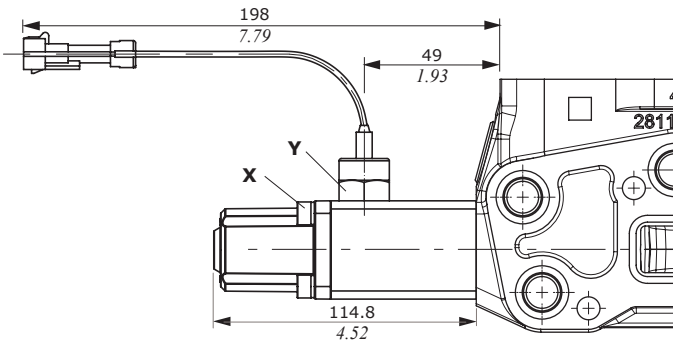
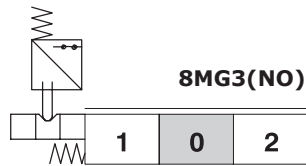

Complete controls			
Circuit	Microswitch operation		
	position 1 <b>8MG1</b>	position 2 <b>8MG2</b>	positions 1, 2 <b>8MG3</b>
(NO)	5V08110060	5V08110070	5V08110050
(NC)	/	/	5V08110053

Features

MICROSWITCH  
Mechanical life ..... : 5x10<sup>5</sup> operations  
Electrical life (resistive load) .. : 10<sup>5</sup> oper. - 7A / 13.5VDC  
: 5x10<sup>4</sup> oper. - 10A / 12VDC  
: 5x10<sup>4</sup> oper. - 3A / 28VDC  
Connector ..... : Packard Weather-pack  
Mating connector cod. 5CON001 not included

8MG19/MG29 type

With double microswitch in position 1 and 2. It requires **MG** working section kit. See page 27.

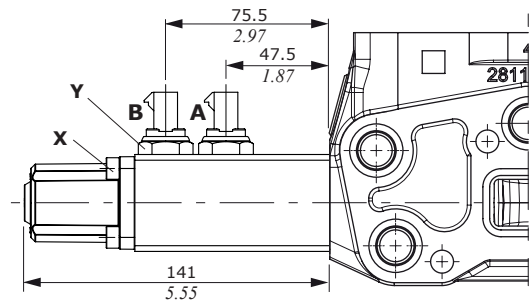
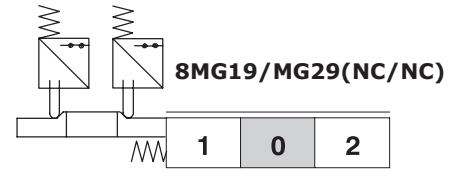

Positions	A	B
1	•/•	•/•
0	•/•	•/•
2	•/•	•/•

Wrenches and tightening torques

X = wrench 5 - 9.8 Nm (7.23 lbft)  
Y = wrench 22 - 24 Nm (17.7 lbft)

Features

MICROSWITCH  
Mechanical life ..... : 5X10<sup>5</sup> operations  
Electrical life (resistive load) .. : 10<sup>5</sup> oper. - 7A / 13.5VDC  
: 5x10<sup>4</sup> oper. - 10A / 12VDC  
: 5x10<sup>4</sup> oper. - 3A / 28VDC  
Connector ..... : Packard Weather-pack  
Mating connector cod. 5CON140047 not included

Dedicated parts	Type	Code
Working section kit for 8MG.. positioners	S(MG)	5EL3187001A
	PHT(MG)	5EL1187080D
	RPHT(MG)	5EL1187057D
	RQHT(MG)	5EL1187056D
	PH(MG)	5EL1187000C

Electromagnetic detent 8RMN2 type

Wrenches and tightening torques

X = wrench 5 - 9.8 Nm (7.23 lbft)

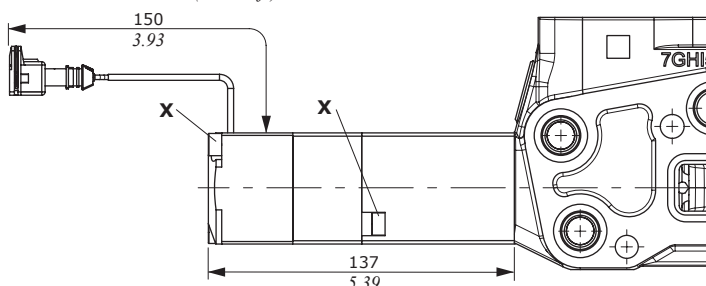
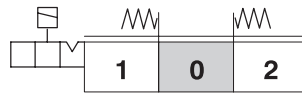

Features

Nominal voltage ..... : 12-24 VDC (± 10%)  
Power rating ..... : 5.2 W  
Resistance ..... : 26-29.8 Ω - 12VDC  
: 102-118 Ω - 24VDC  
Duty cycle ..... : 100%  
Connector ..... : AMP JPT 2P  
Unlocking force ..... : 380N (85.4 lbf)  
Mating connector cod. W0251001 not included

"A" side spool positioners

ON/OFF pneumatic kit and ON/OFF electro-pneumatic kit

Pneumatic: 8PG type

With spring return to neutral position. It requires **MG** working section kit. See page 27.

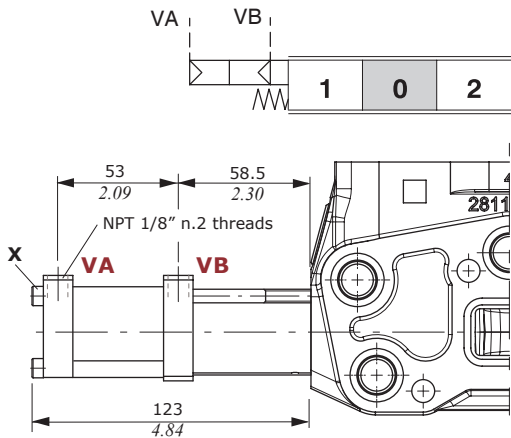

Dedicated parts	Type	Code
	S(MG)	5EL3187001A
Working section kit for 8PG and 8EPG3 positioners	PHT(MG)	5EL1187080D
	RPHT(MG)	5EL1187057D
	RQHT(MG)	5EL1187056D
	PH(MG)	5EL1187000C

Electro-pneumatic: 8EPG3 type

It requires **MG** working section kit. See page 27.

Wrenches and tightening torques

- X = wrench 5 - 9.8 Nm (7.23 lbft)
- Y = wrench 13 - 1.5 Nm (1.11 lbft)
- W = wrench 15 - 6.6 Nm (4.87 lbft)

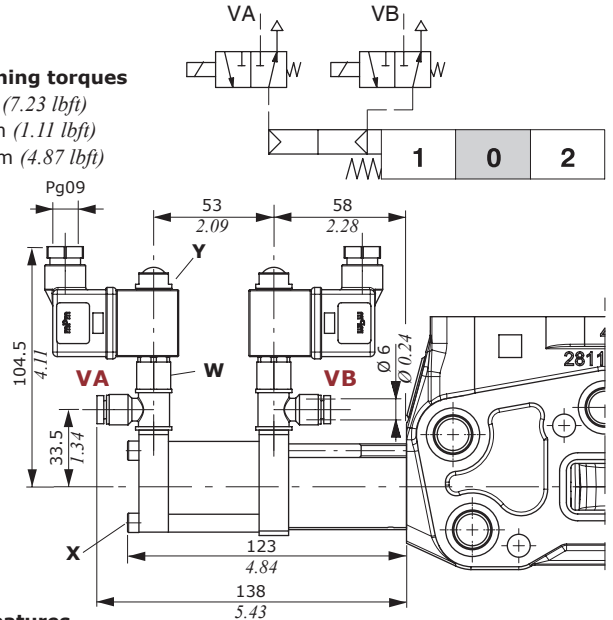

Common features

- Pilot pressure..... : min. 6 bar (min. 85 psi)
- : max. 12 bar (min. 174 psi)
- For **BPV** coil see page 80

ON/OFF pneumatic waterproof kit and ON/OFF electro-pneumatic waterproof kit

Pneumatic: 8PDG type

It requires **MG** working section kit. See page 27.

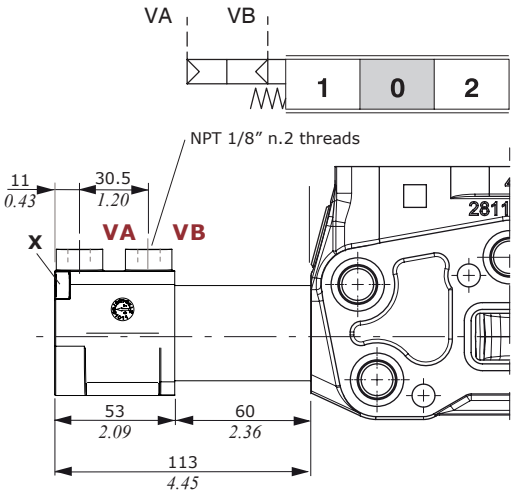

Dedicated parts	Type	Code
	S(MG)	5EL3187001A
Working section kit for 8PDG and 8EPDG3 positioners	PHT(MG)	5EL1187080D
	RPHT(MG)	5EL1187057D
	RQHT(MG)	5EL1187056D
	PH(MG)	5EL1187000C

Electro-pneumatic: 8EPDG3 type

It requires **MG** working section kit. See page 27.

Wrenches and tightening torques

- X = wrench 5 - 9.8 Nm (7.23 lbft)
- Y = wrench 13 - 1.5 Nm (1.11 lbft)
- W = wrench 15 - 6.6 Nm (4.87 lbft)

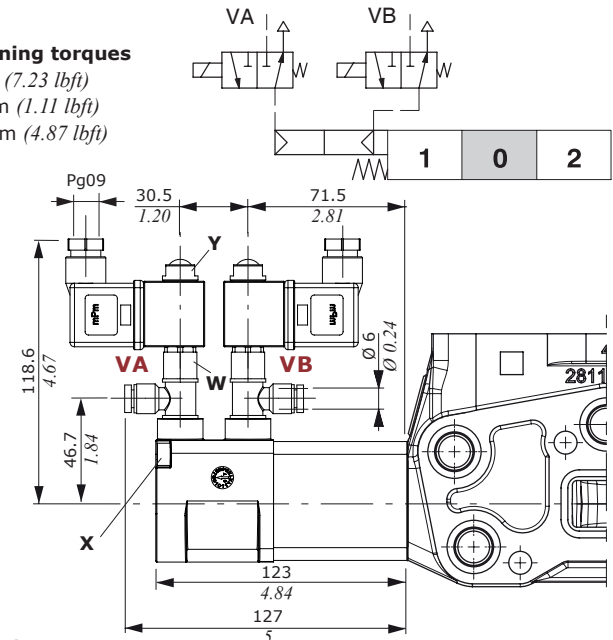

Common features

- Pilot pressure..... : min. 6.5 bar (min. 90 psi)
- : max. 12 bar (min. 174 psi)
- For **BPV** coil see page 80

"A" side spool positioners

Unilateral hydraulic proportional spool control kit 8IZ

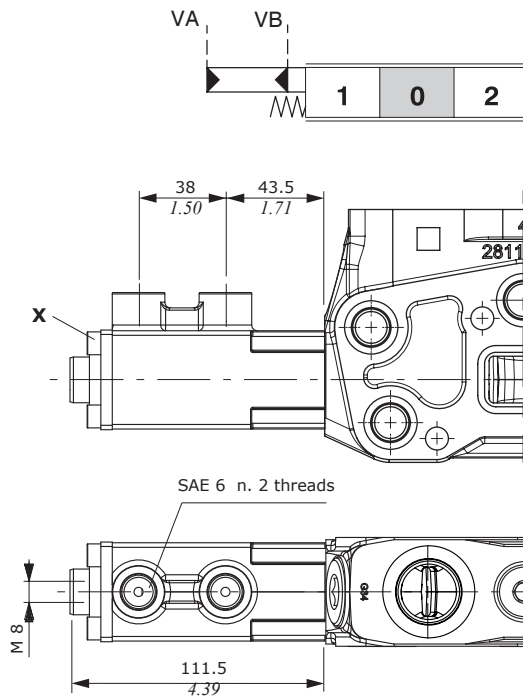

Dedicated parts	Type	Code
Working section kit for 8IZ positioner	S(MG)	5EL1183201
	PHT(MG)	5EL1183080B
	RPHT(MG)	5EL1183057D
	RQHT(MG)	5EL1183056D
	PH(MG)	5EL1183000C

Wrenches and tightening torques

X = wrench 5 - 9.8 Nm (7.23 lbft)

Features

adjustment range ..... : from 8 to 22 bar  
(from 110 to 310 psi)

Pressure - stroke diagram

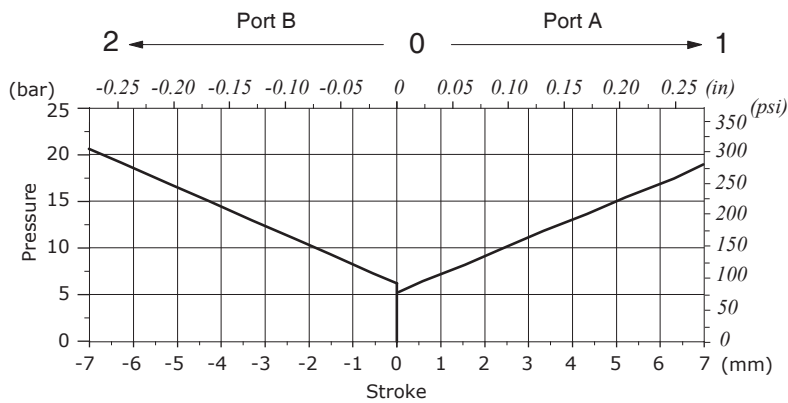



"A" side spool positioners

ON/OFF electro-hydraulic control 8EI3 type

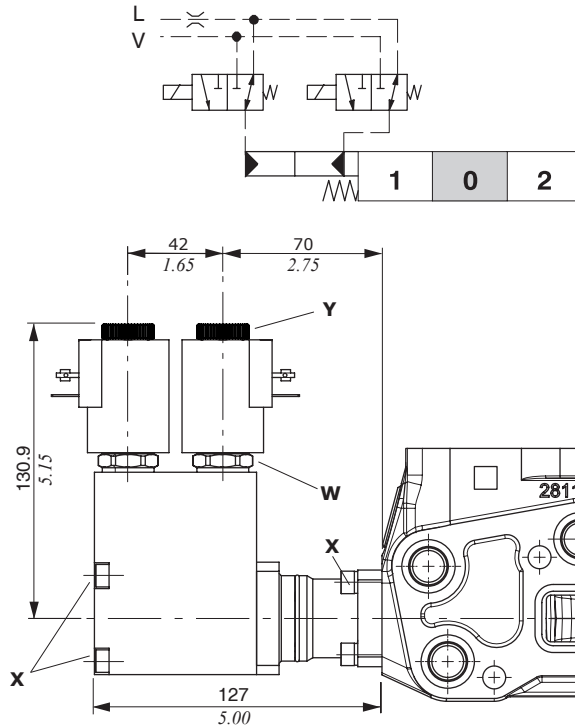

Features

Pilot pressure..... : min. 10 bar (145 psi)  
 : max. 50 bar (725 psi)  
 Max backpressure on drain L... : 25 bar (360 psi)  
 For BT coil and mating connectors see page 80

Wrenches and tightening torques

X = wrench 5 - 9.8 Nm (7.23 lbft)  
 Y = wrench 21 - 6.6 Nm (4.87 lbft)  
 W = wrench 24 - 9.8 Nm (7.23 lbft)

Collector kit for external pilot and drain

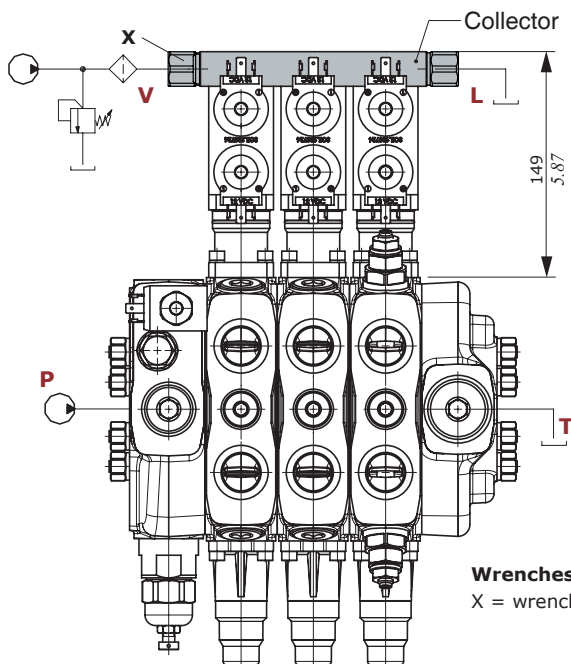

Wrenches and tightening torques

X = wrench 6 - 24 Nm (17.7 lbft)

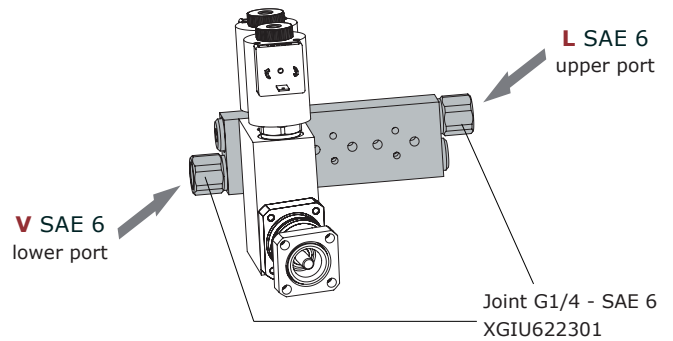

COLLECTOR KIT CODES

Type	Code *	Description
KE1S0	5KE1S00070	Kit for one section
KE2S0	5KE2S01570	Kit for 2 sections
KE3S0	5KE3S01570	Kit for 3 sections
KE4S0	5KE4S01570	Kit for 4 sections
KE5S0	5KE5S01570	Kit for 5 sections
KE6S0	5KE6S01570	Kit for 6 sections
KE7S0	5KE7S01570	Kit for 7 sections

(\*) codes are referred to SAE thread

Description example:  
 SDS180/3/AC(XG-210)R2E/18EI3SLCZ/18EI3SLCZ/  
 18EI3SLCZ.UX3(G-230)/RC-KE3S0-SAE-12VDC

"A" side spool positioners

ON/OFF electro-hydraulic kit 8E13 type

Collector kit for internal pilot and drain

The kit include collector, VRP pressure reducing valve and pipes.

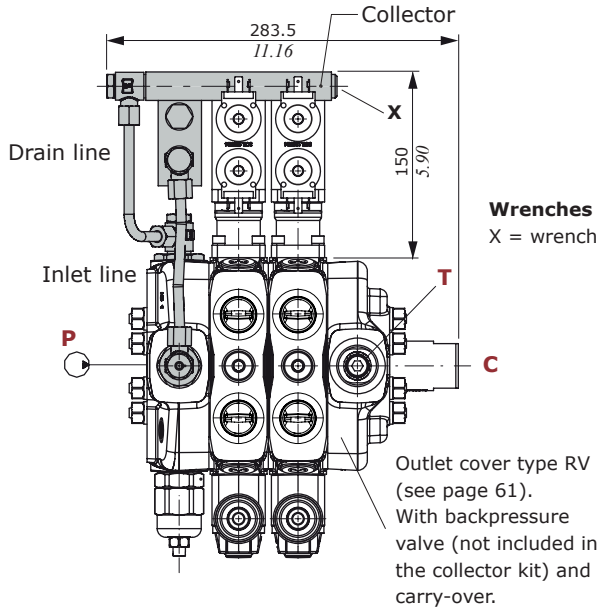

COLLECTOR KIT CODES		
Type	Code *	Description
KE1R3	5KE1R31570	Kit for one section
KE2R3	5KE2R31570	Kit for 2 sections
KE3R3	5KE3R31570	Kit for 3 sections
KE4R3	5KE4R31570	Kit for 4 sections
KE5R3	5KE5R31570	Kit for 5 sections
KE6R3	5KE6R31570	Kit for 6 sections
KE7R3	5KE7R31570	Kit for 7 sections

(\*) codes are referred to SAE thread

Description example:  
 SDS180/2/AC(YG3-120)/1CS8E13L/1CS8E13L/  
**RV-KE2R3-SAE-24VDC**

Features

VRP VALVE

Output pressure. . . . . : 20 bar (290 psi)  
 Nominal flow . . . . . : 8 l/min (2.1 US gpm)  
 Filtering . . . . . : 80 µm

VRE backpressure valve

Valve VRE (code X111072010) assembled on flow through passage to provide pilot pressure to the actuator. The minimum backpressure is 10 bar (145 psi).

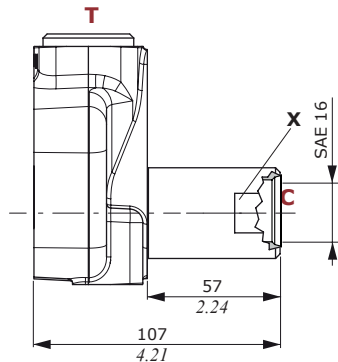

Wrenches and tightening torques  
 X = wrench 36 - 42 Nm (31 lbf<sub>t</sub>)

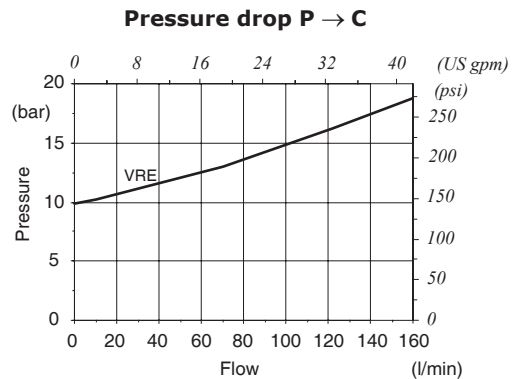

"A" side spool positioners

Particular positioner kits for special spools

11A

With detent in position 1 and 2, and automatic release in neutral position. It requires **PHT** working section kit and **1(11A)**. See page 27.

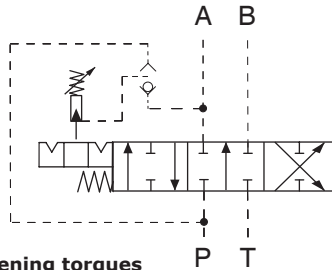

Wrenches and tightening torques

- X = wrench 5 - 9.8 Nm (7.23 lbf<sub>t</sub>)
- Y = wrench 10- 9.8 Nm (7.23 lbf<sub>t</sub>)
- V = wrench 24 - 9.8 Nm (7.23 lbf<sub>t</sub>)
- W = allen wrench 3

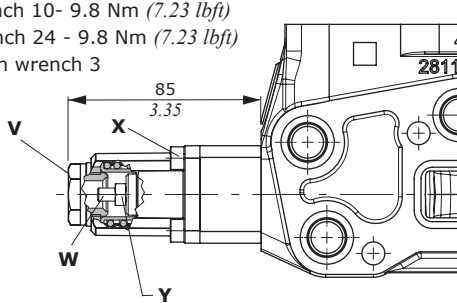

Dedicated parts	Type	Code
Spool	1(11A)	3CU2510321
Working section kit	PHT	5EL1187080

Features

Release pressure . . . . . : from 20 to 180 bar  
(from 290 to 2600 psi)

13MD

Detent in 4<sup>th</sup> position with spring return in neutral position with detent spool in type.

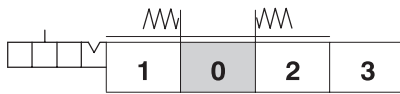

Wrenches and tightening torques

- X = wrench 5 - 9.8 Nm (7.23 lbf<sub>t</sub>)

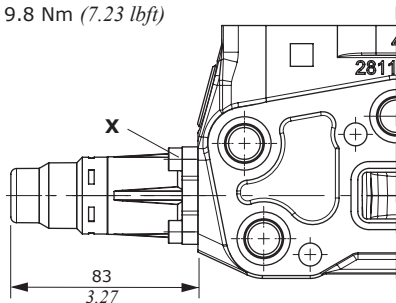

Dedicated parts	Type	Code
Spool	5	3CU2541200
Working section kit left inlet	P5	5EL1187200
Working section kit right inlet	P5ED	5EL1187260

"A" side spool positioners

Particular positioner kits for regenerative spools

8CR type

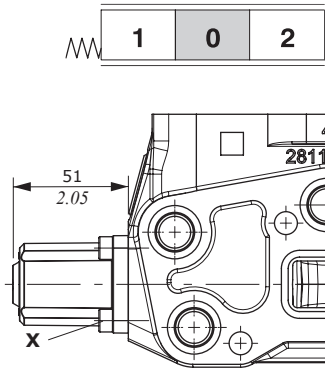

**Wrenches and tightening torques**  
X = wrench 5 - 9.8 Nm (7.23 lbf<sub>t</sub>)

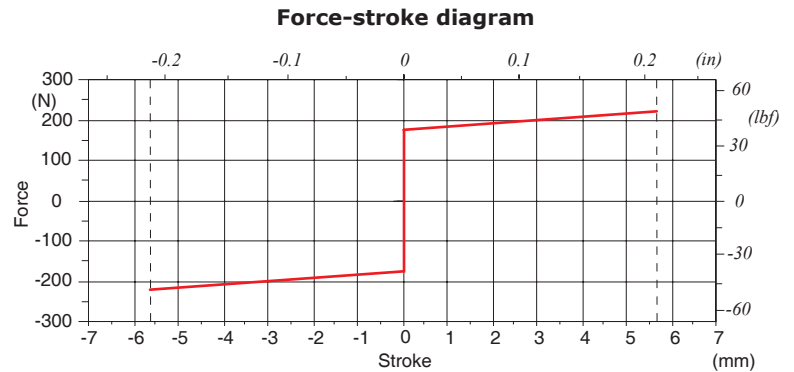

**Spool stroke**  
position 1: + 5.7 mm (+ 0.22 in) - position 2: - 5.7 mm (- 0.22 in)

Dedicated parts	Type	Code
Spools	8PF	3CU2561210
	8PGF	3CU2561215
Working section	PH	5EL1187000

9BCR-10BCR types

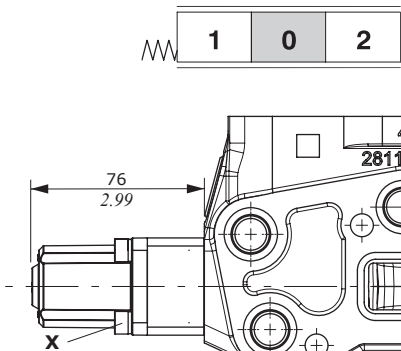

**Wrenches and tightening torques**  
X = wrench 5 - 9.8 Nm (7.23 lbf<sub>t</sub>)

Dedicated parts	Type	Code
Spools	8PF	3CU2561210
	8PGF	3CU2561215
Working section	PH	5EL1187000

8PGCR type

It requires **MG** working section kit. See page 27.

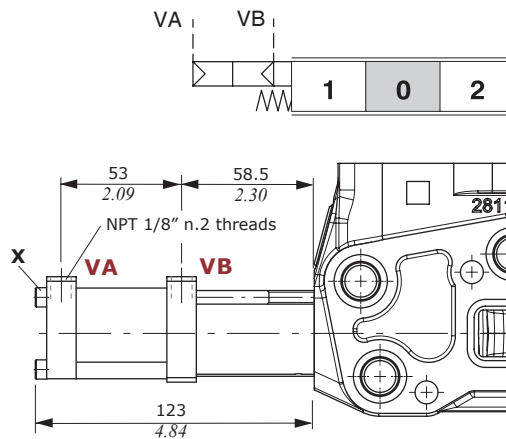

**Wrenches and tightening torques**  
X = wrench 5 - 9.8 Nm (7.23 lbf<sub>t</sub>)  
Y = wrench 13 - 1.5 Nm (1.11 lbf<sub>t</sub>)  
W = wrench 15 - 6.6 Nm (4.87 lbf<sub>t</sub>)

**Features**  
Pilot pressure.....: min. 6 bar (min. 85 psi)  
: max. 12 bar (min. 174 psi)

Dedicated parts	Type	Code
Spools	8PF	3CU2561210
	8PGF	3CU2561215
Working section	PH(MG)	5EL1187000C

"A" side spool positioners

Particular positioner kits for regenerative spools

8EPG3CR type

It requires **MG** working section kit. See page 27.

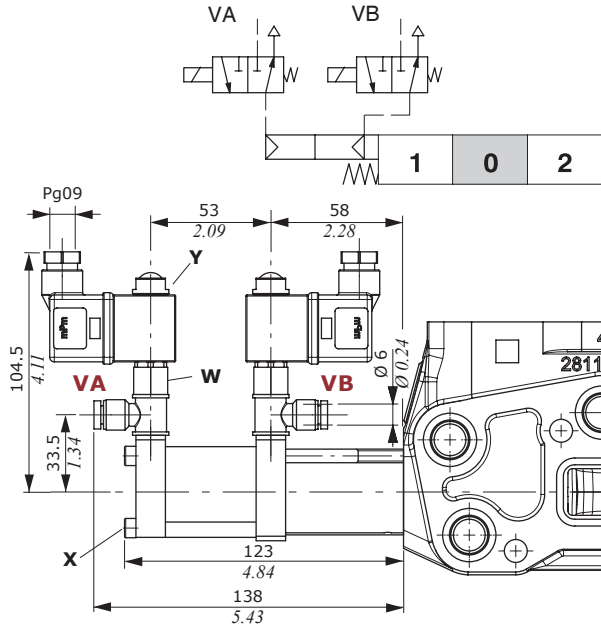

**Wrenches and tightening torques**

- X = wrench 5 - 9.8 Nm (7.23 lbft)
- Y = wrench 13 - 1.5 Nm (1.11 lbft)
- W = wrench 15 - 6.6 Nm (4.87 lbft)

**Features**

Pilot pressure.....: min. 6 bar (min. 85 psi)  
: max. 12 bar (min. 174 psi)

For **BPV** coil see page 80

Dedicated parts	Type	Code
Spools	8PF	3CU2561210
	8PGF	3CU2561215
Working section	PH(MG)	5EL1187000C

8EI3CR type

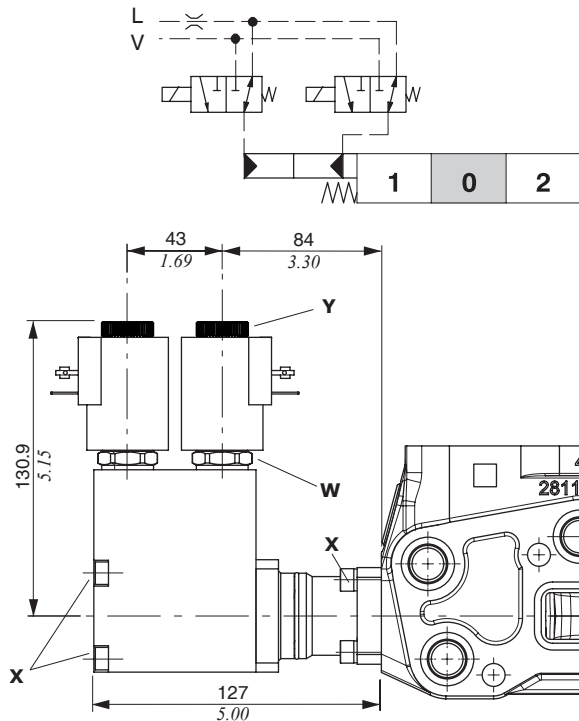

**Wrenches and tightening torques**

- X = wrench 5 - 9.8 Nm (7.23 lbft)
- Y = wrench 21 - 6.6 Nm (4.87 lbft)
- W = wrench 24 - 9.8 Nm (7.23 lbft)

**Features**

Pilot pressure.....: min. 10 bar (145 psi)  
: max. 50 bar (725 psi)

Max backpressure on drain L...: 25 bar (360 psi)

For **BT** coil and mating connectors see page 80

Dedicated parts	Type	Code
Spools	8PF	3CU2561210
	8PGF	3CU2561215
Working section	PH	5EL1187000

“B” side options

Lever control

L type

Alluminium lever pivot box with protective rubber bellow; it can be roated 180° (configuration **L180**).

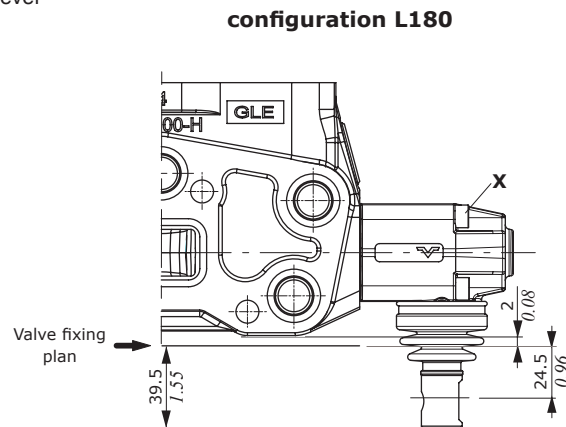
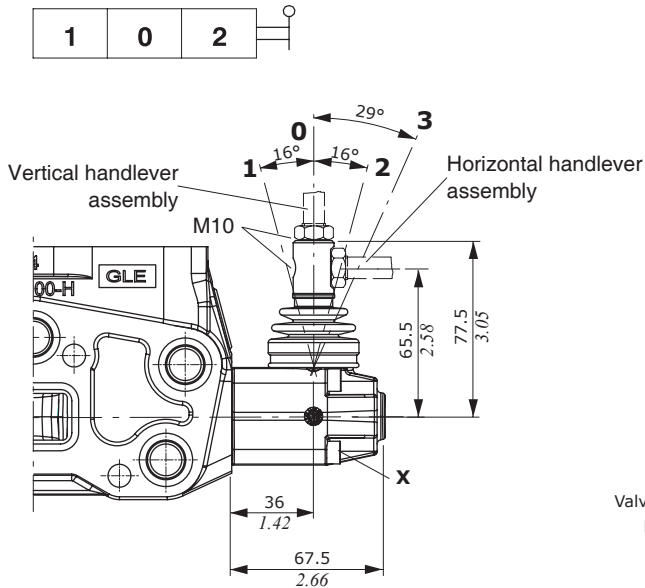

**Wrenches and tightening torques**

X = wrench 5 - 9.8 Nm (7.23 lbft)

LF1 type

With spool stroke adjustment in position 12 (P→A). It can be roated 180° (configuration **LF1180**).

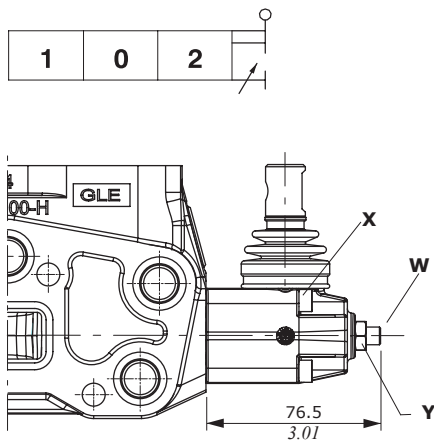

**Wrenches and tightening torques**

X = wrench 5 - 9.8 Nm (7.23 lbft)

Y = wrench 13 - 24 Nm (17.7 lbft)

W = allen wrench 4

LB type

Steel construction, LB1 with pivot placed down and LB3 with pivot placed over.

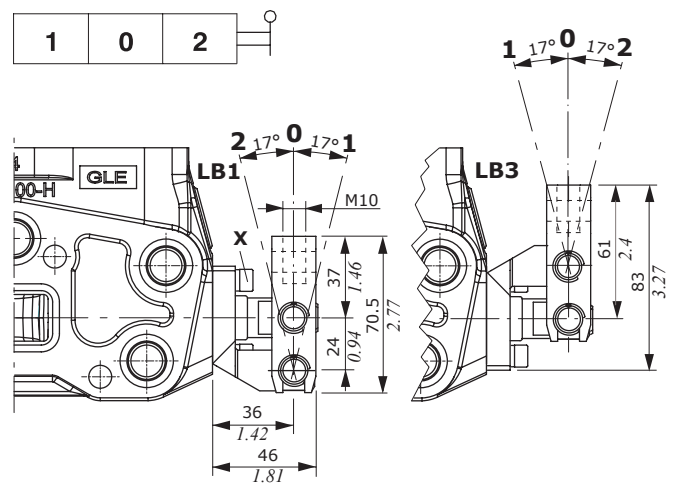

**Wrenches and tightening torques**

X = wrench 5 - 9.8 Nm (7.23 lbft)

NOTE – Due to limited space in case of L, LF1, LB1 or LB3 configuration the assembly of UXW and PX port valves is not possible.

LCB and LCE mechanical joysticks for two sections control

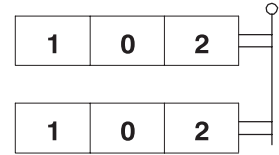
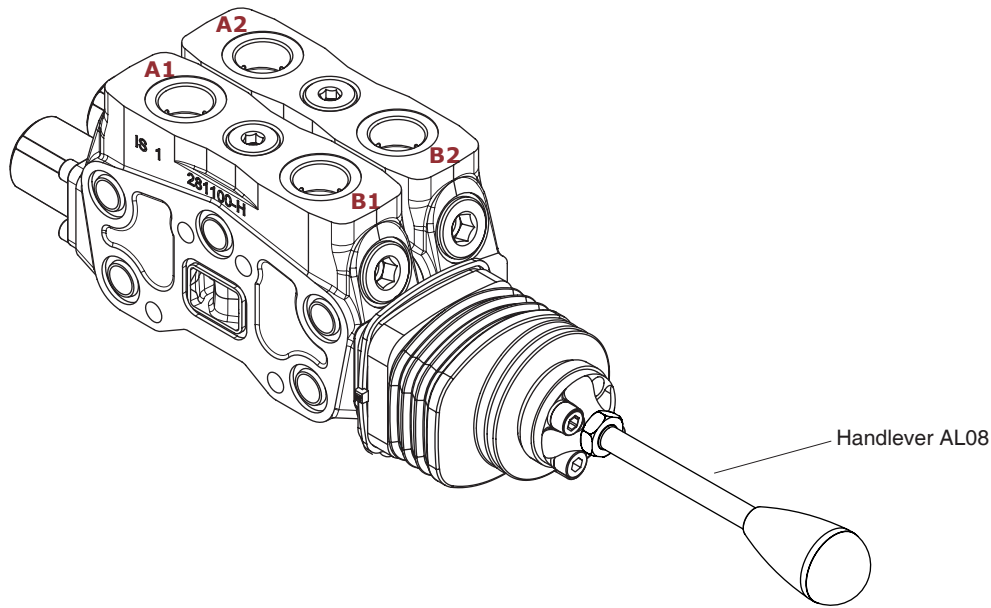

NOTE - The handlever must be ordered separately (see page 29).

Dimensions and movement scheme for left inlet directional valve

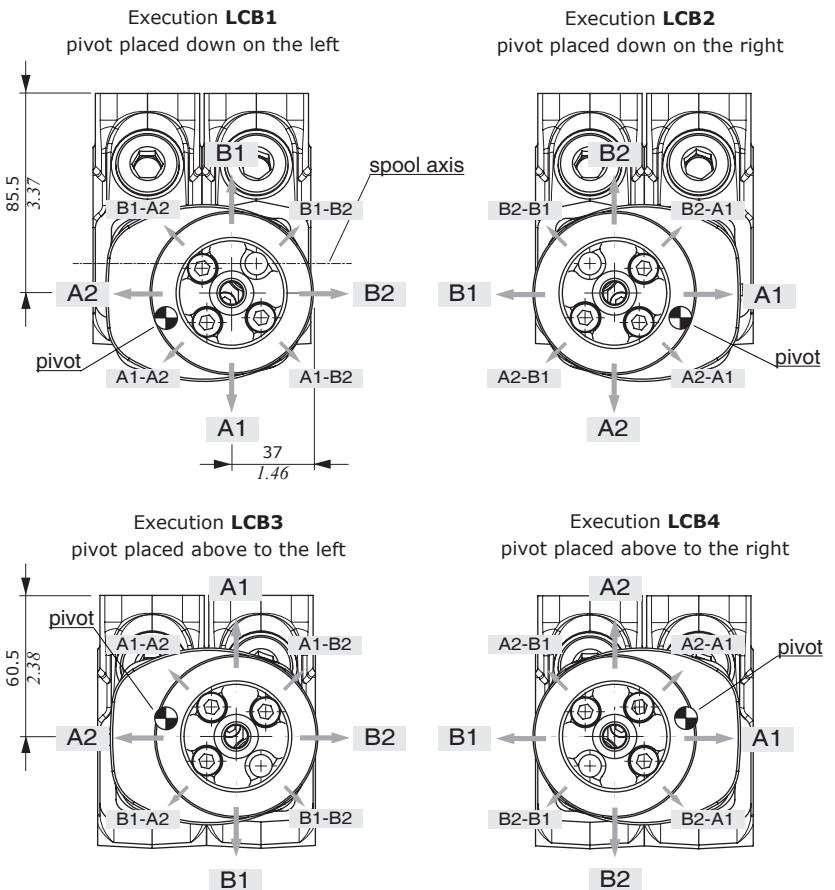
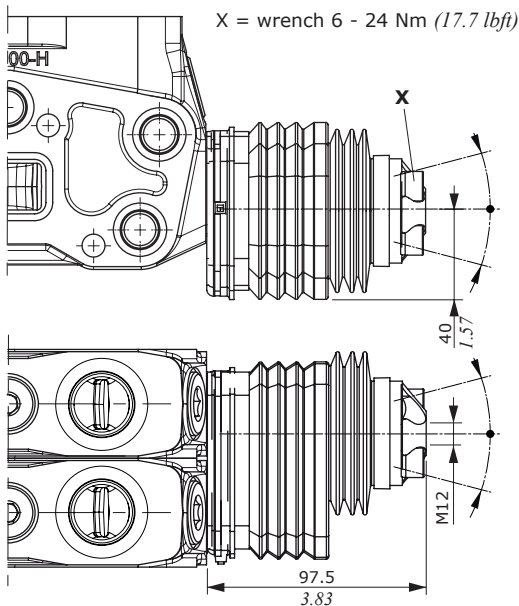

Max. working angles	Horizontal axis	Vertical axis
Single action operation	18°30'	15°30'
Single action operation with floating	not available	not available
Two section operation	18°30'	15°30'
Two section operation with floating	not available	not available

NOTE - Due to limited space in case of LCB3 or LCB4 configuration the assembly of port valves is not possible.

## "B" side options

### SL type

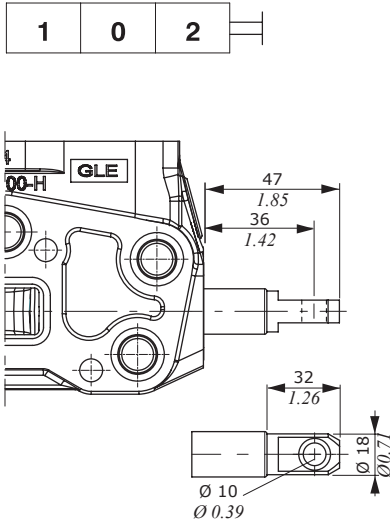

### SLP type

Mechanical control with dust-proof plate kit.

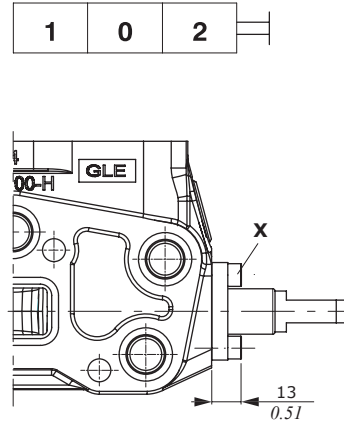

#### Wrenches and tightening torques

X = wrench 5 - 9.8 Nm (7.23 lbft)

### TQ cable remote control kit

Prearranged for remote control with flexible cable.

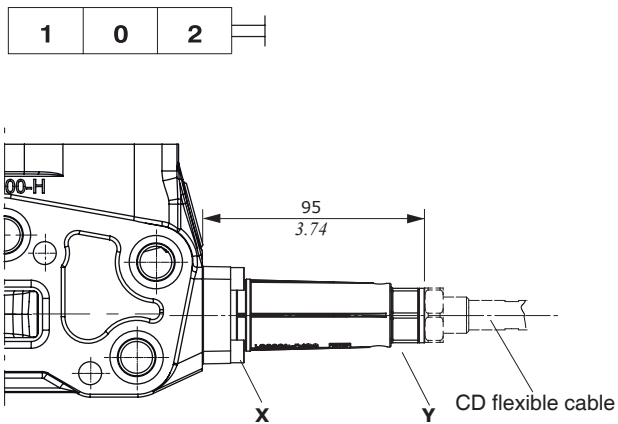

#### Wrenches and tightening torques

X = wrench 5 - 9.8 Nm (7.23 lbft)

Y = allen wrench 24

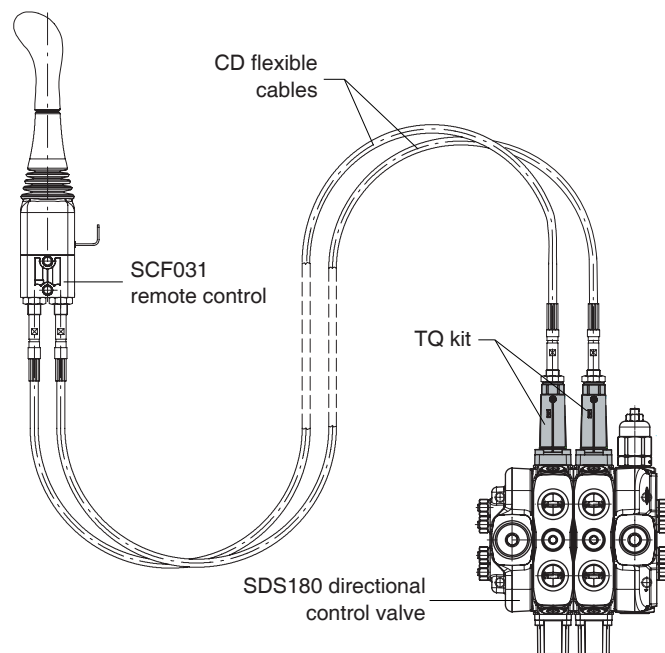

NOTE - For more information about remote cable control, require appropriate documentation.



**Proportional hydraulic controls**

Needs dedicated spool and working section kit without spool seals. (See page 31).

**8IMOHF3 type**

Configuration with screws for spool stroke adjustment.

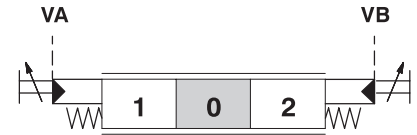
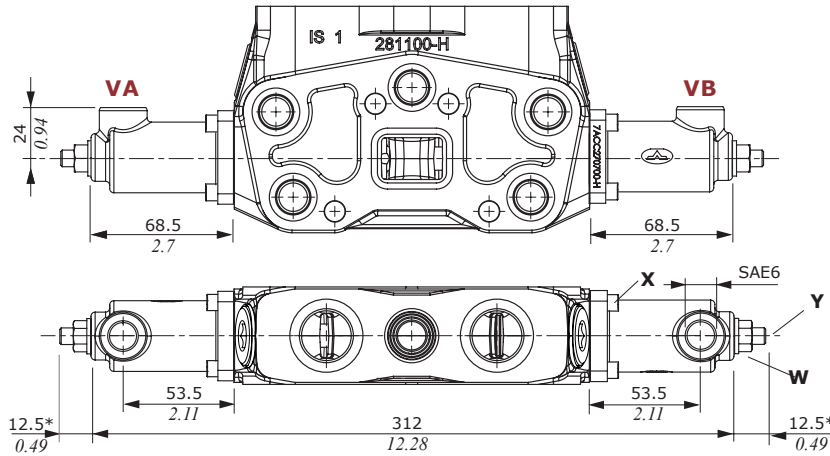

**Wrenches and tightening torques**

X = wrench 5 - 9.8 Nm (7.23 lbf<sub>t</sub>)

Y = allen wrench 4

W = wrench 13 - 24 Nm (17.7 lbf<sub>t</sub>)

**8IMOHF3 type features**

Adjustment range . . . . . : from 5.8 to 19 bar  
(from 84.1 to 275 psi)  
see curve type 033

Pilot pressure . . . . . : max. 100 bar (1450 psi)

\* depends on stroke setting

**8IMOH type**

Steel control kit.

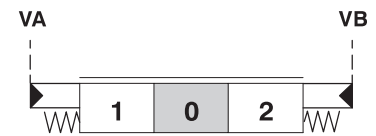
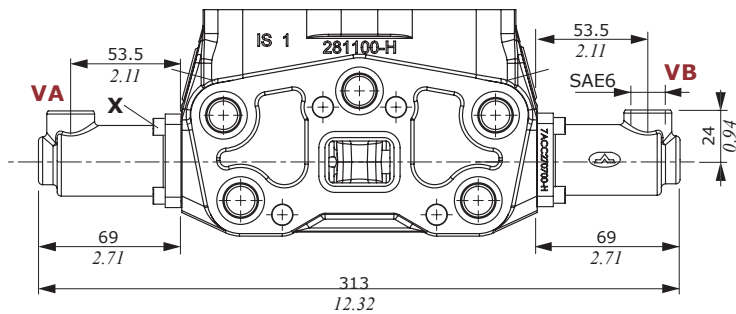

**Wrenches and tightening torques**

X = wrench 5 - 9.8 Nm (7.23 lbf<sub>t</sub>)

**8IMOH type features**

Adjustment range . . . . . : from 5.8 to 19 bar  
(from 84.1 to 275 psi)  
see curve type 033

Pilot pressure . . . . . : max. 50 bar (730 psi)

**Diagrams and features of proportional hydraulic controls**

**Pressure - stroke diagram**  
(for controls represented)

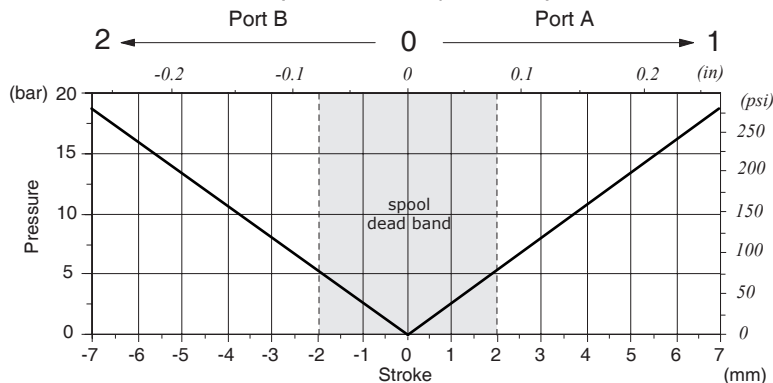

**Pressure control curve on port VA and VB: type 033**

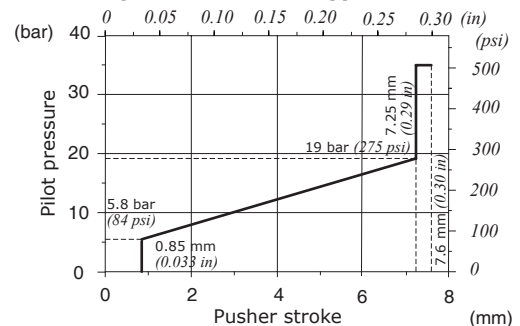

**Features**

Pilot pressure . . . . . : max. 100 bar (1450 psi)

Complete controls

Proportional hydraulic control

8IMSPSL proportional hydraulic kit

With spool position sensor. For other features see the catalogue cod. D1WWEE01A.

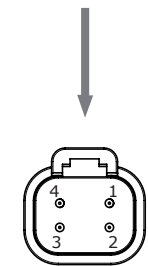
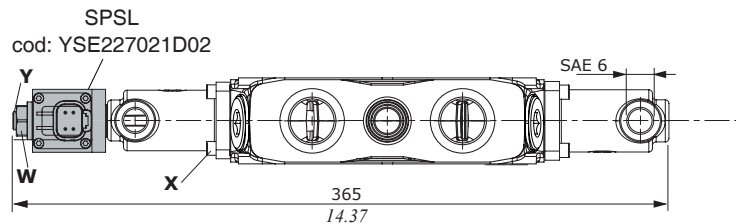
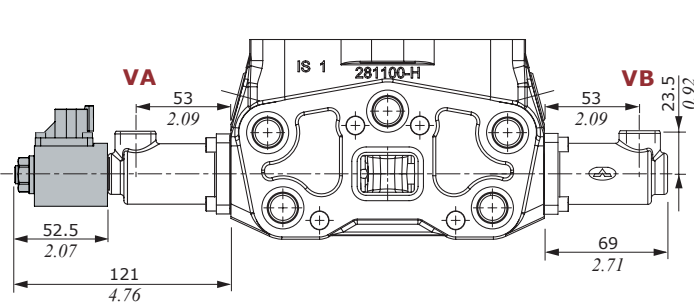

Pin	Functions	
	for 5V supply	for 8-32V supply
1	+5V	signal OUT
2	N.C.	GND
3	GND	Vb+
4	signal Out	not connected

NOTE - these drawings are not to scale with the others included in the catalog

Output Voltage-spool stroke diagram

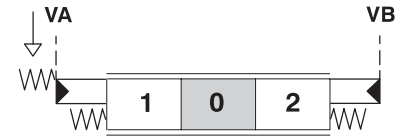
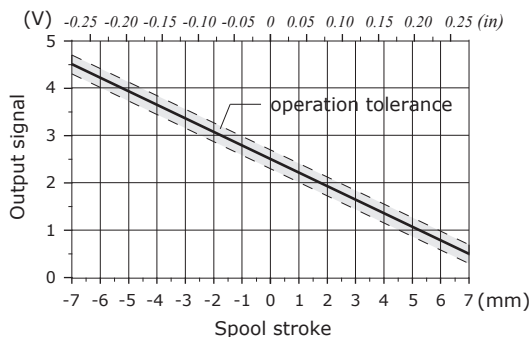

Wrenches and tightening torques

- X = wrench 5 - 9.8 Nm (7.23 lbft)
- Y = wrench 17 - 9.8 Nm (7.23 lbft)
- W = wrench 4 - 9.8 Nm (7.23 lbft)

Control features

- Pilot pressure . . . . . : max. 100 bar (1450 psi)
- Connector . . . . . : Deutsch DT04-4P
- Mating connector cod. 5CON140072 not included

Spool position sensor features

- Voltage supply range . . . . . : from 9 to 32 VDC or 5 VDC
- Current absorption . . . . . : <10 mA
- Mechanical life . . . . . : 3x10<sup>6</sup>
- Connector type . . . . . : Deutsch DT04-4P
- Weather protection . . . . . : IP 67 - IP 69K
- Working temperature . . . . . : -40/+105 °C
- Minimum load resistance . . . . . : 10 KΩ
- Working pressure max. . . . . : 350 bar • 5100 psi
- Max. mechanical stroke . . . . . : ±10 mm
- Max. electrical stroke . . . . . : ±10mm
- Output signal
  - Range . . . . . : from 0.5 to 4.5 V
  - Linearity . . . . . : ±5%
  - Spool in neutral . . . . . : 2.5 ± 0.2 V
  - Max current . . . . . : 1 mA
- Mechanical vibrations, shock, bumps . . . . . : IEC 68-2-6,27,29
- EMC compatibility . . . . . : ISO 13766 - ISO 15982

Proportional hydraulic control

8IMD proportional hydraulic kit

For descent control valve on A. Needs dedicated 1MDA spool, code: **3CU2510490**.

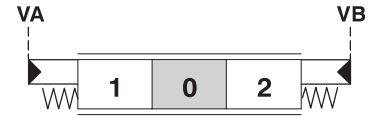
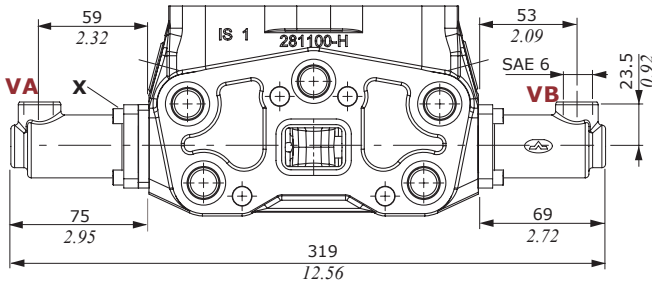

Features

- Adjustment range . . . . . : From 5 to 20 bar  
(from 72.5 to 290 psi)
- Pilot pressure . . . . . : max. 100 bar (1450 psi)

Wrenches and tightening torques

X = wrench 5 - 9.8 Nm (7.23 lbft)

NOTE - these drawings are not to scale with the others included in the catalog

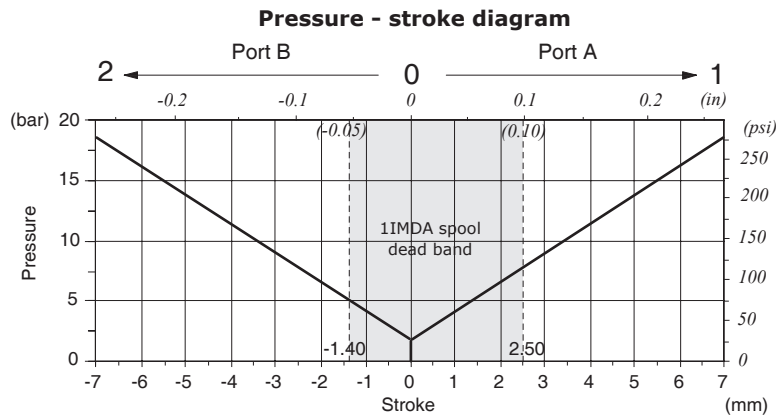
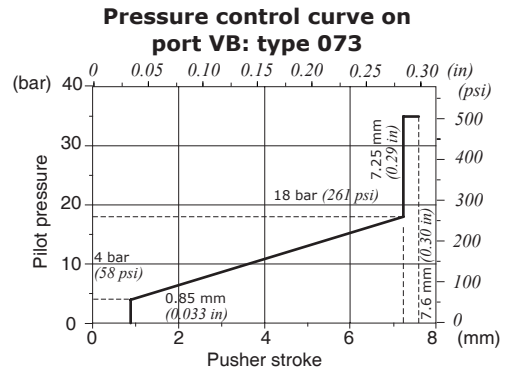
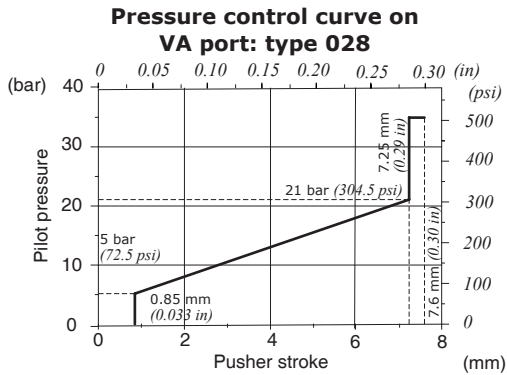

Complete controls

Proportional hydraulic control

13IMP and 13IMOPHCR proportional hydraulic kit

For floating circuit.

13IMP

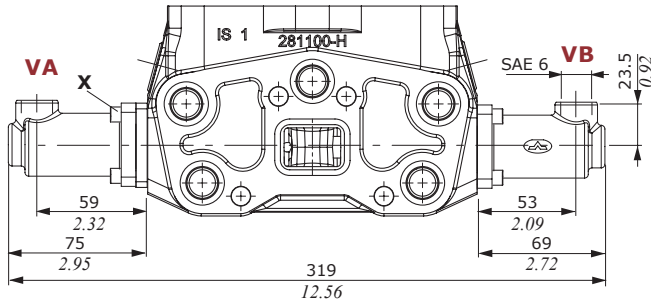

**Wrenches and tightening torques**  
X = wrench 5 - 9.8 Nm (7.23 lbft)

13IMOPHCR

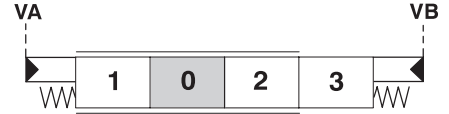
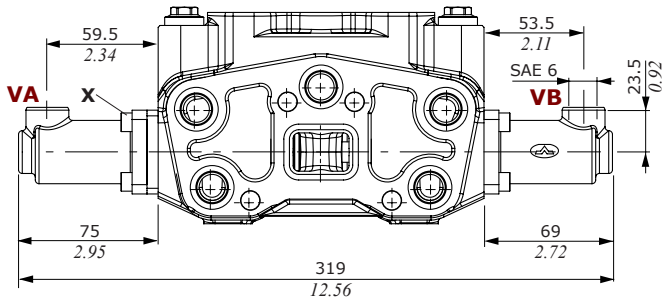

13 IMP		
Dedicated parts	Type	Code
Spool	5IMP	3CU2542430
Working section kit	P5(IMP)	5EL1185205A

13IMOPHCR		
Dedicated parts	Type	Code
Spool	5HFLIM	3CU2541210-H
Working section kit	RPH5LL(IM)	5EL1187058

**Features**

Adjustment range . . . . . : From 5 to 20 bar  
(from 72.5 to 290 psi)

Pilot pressure . . . . . : max. 100 bar (1450 psi)

NOTE - these drawings are not to scale with the others included in the catalog

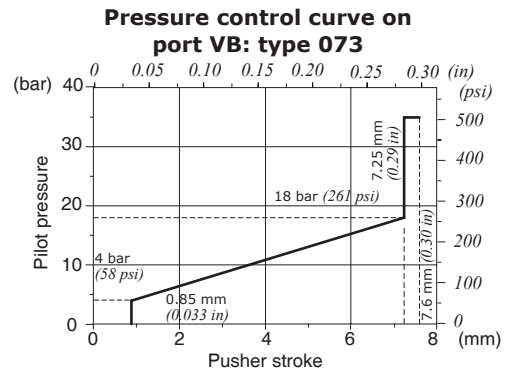
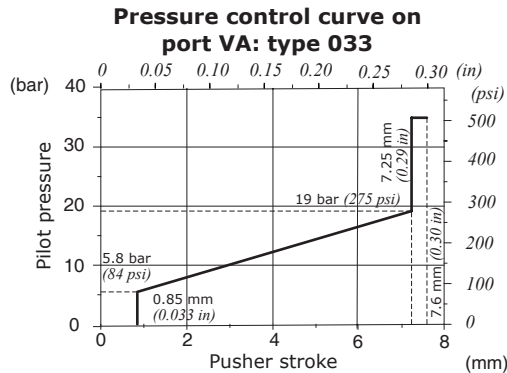

**Pressure - stroke diagram**

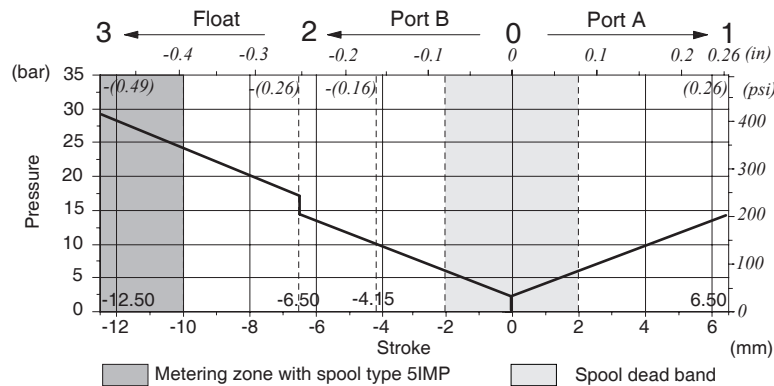

Antishock valves

P 1 (G 3 - 100)

Valve setting (bar)

Spring type

Configuration

- 1 mounted on port A
- 2 mounted on port B
- 3 mounted on ports A and B

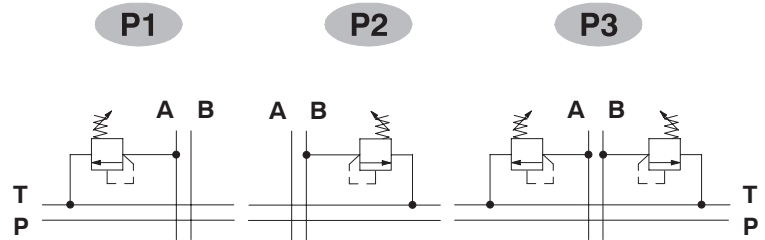

Configuration type G:  
with screw

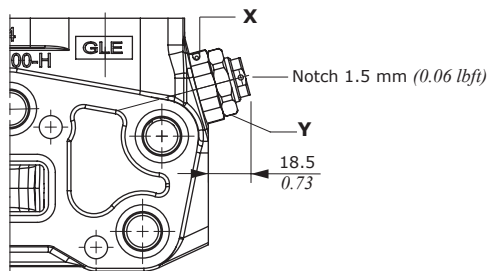

Configuration type H:  
valve set and locked

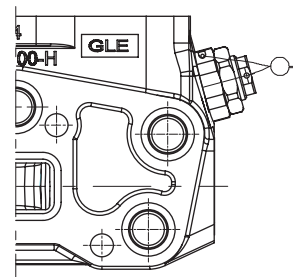

Wrenches and tightening torques

X = wrench 30 - 42 Nm (31 lbf)

Y = wrench 27 - 24 Nm (17.7 lbf)

G2 setting range

From 50 to 120 bar (from 725 to 1750 psi)

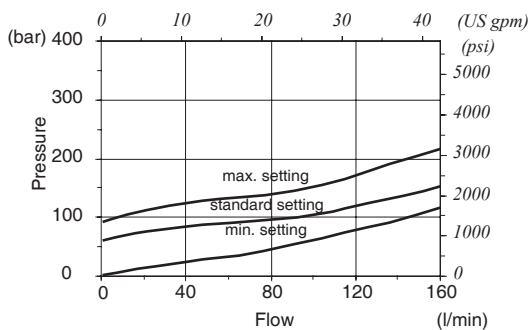

G3 setting range

From 100 to 250 bar (from 1450 to 3600 psi)

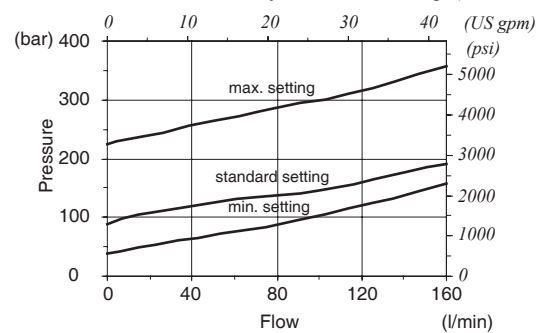

G4 setting range

From 160 to 315 bar (from 2300 to 4600 psi)

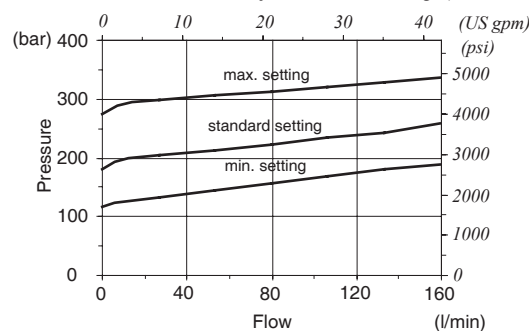

Port valves

Antishock and anticavitation valves

U 1 (G 3 - 100)

- Valve setting (bar)
- Spring type
- Configuration
- 1 mounted on port A
- 2 mounted on port B
- 3 mounted on ports A and B

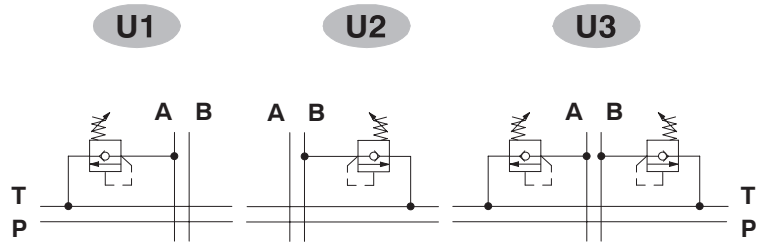

Configuration type G: with screw

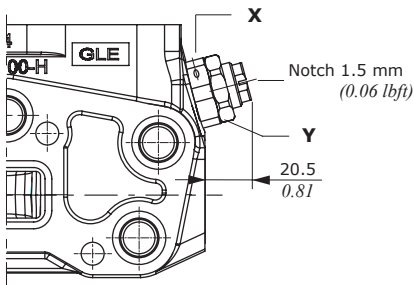

Configuration type H: valve set and locked

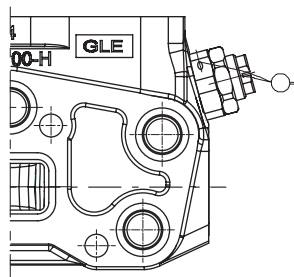

Configuration type Z: with tamper proof cap

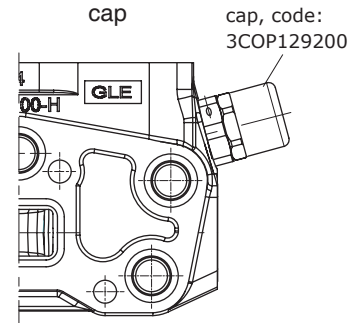

Wrenches and tightening torques

- X = wrench 30 - 42 Nm (31 lbf ft)
- Y = wrench 27 - 24 Nm (17.7 lbf ft)

G2 setting range

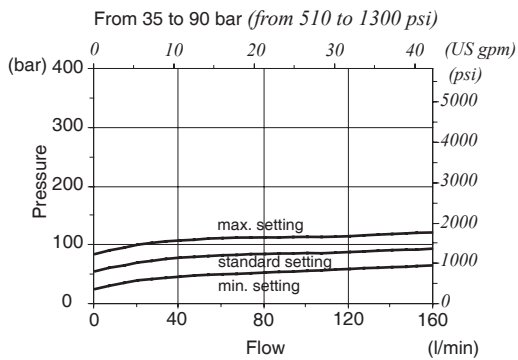

G3 setting range

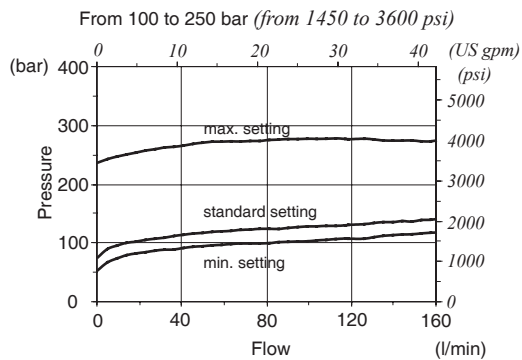

G4 setting range

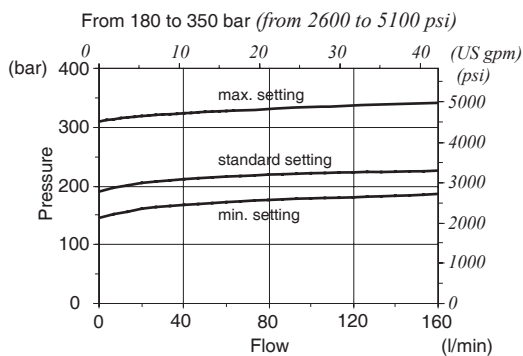

Pressure drop P ⇒ T

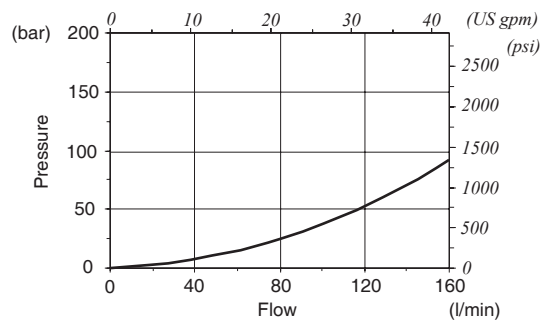

Pilot operated anti-shock and anticavitation valves

UXW 1 (G - 160)

- Pressure setting (bar)
- Configuration
- 1 mounted on port A
- 2 mounted on port B
- 3 mounted on ports A and B

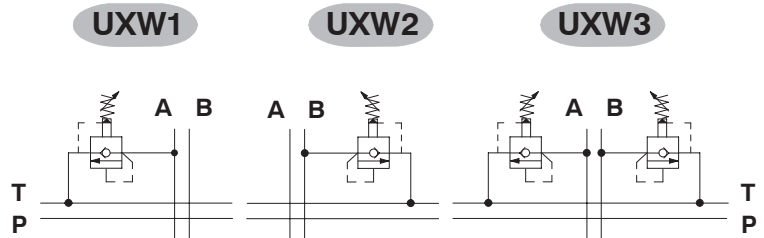

Configuration type G:  
with screw

Configuration type H:  
valve set and locked

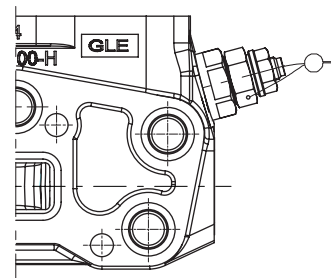
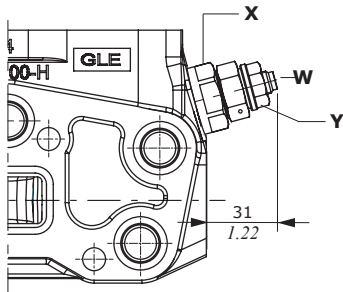

Wrenches and tightening torques

- X = wrench 27 - 42 Nm (31 lbft)
- Y = wrench 17 - 24 Nm (17.7 lbft)
- W = allen wrench 5

Range setting

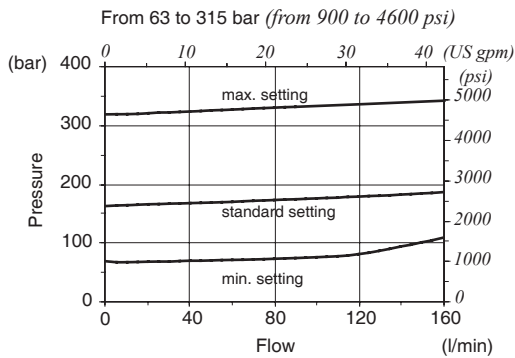

Pressure drop

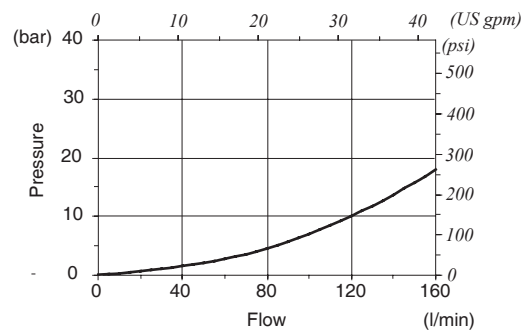

NOTE – The lever control (L type) and the solenoid lock device (8KBER type), combined with the UXV valve, are mounted roated 180° (configuration: **L180** and **8KBER180**).

Port valves

Pilot hydraulic unloader valve

PX 1

- 1 mounted on A port
- 2 mounted on B port
- 3 mounted on A and B ports

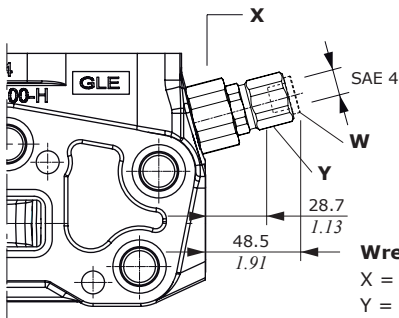

**Wrenches and tightening torques**  
 X = wrench 30 - 42 Nm (31 lbft)  
 Y = wrench 6 - 24 Nm (17.7 lbft)

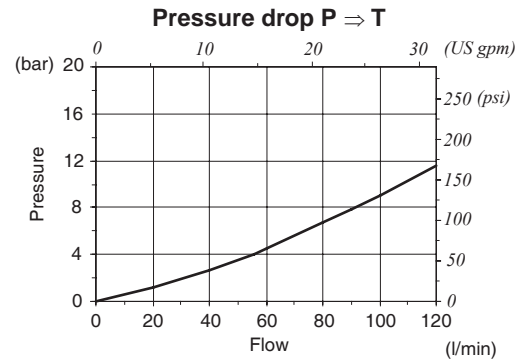
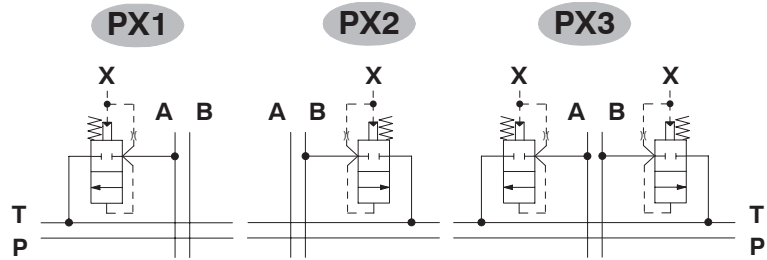

NOTE - For safety reasons the valve is supplied with blanking plug.

The lever control (L type) and the solenoid lock device (8KBER type), combined with the PX valve, are mounted rotated 180° (configuration: **L180** and **8KBER180**).

Anticavitation valve

C 1

- 1 mounted on A port
- 2 mounted on B port
- 3 mounted on A and B ports

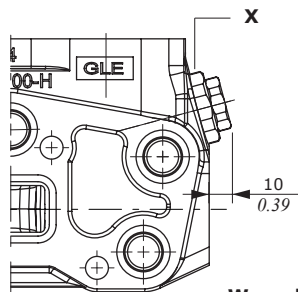

**Wrenches and tightening torques**  
 X = wrench 30 - 42 Nm (31 lbft)

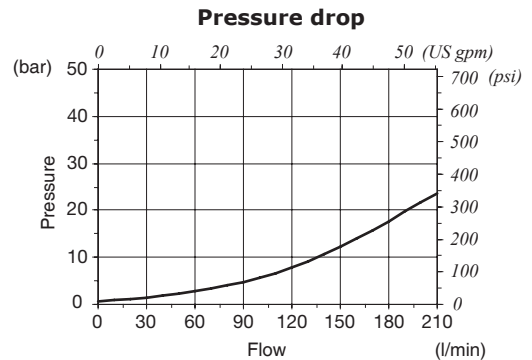
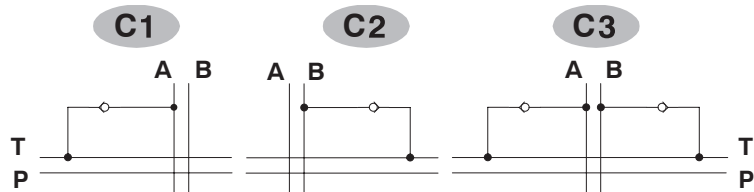

Valve blanking plug

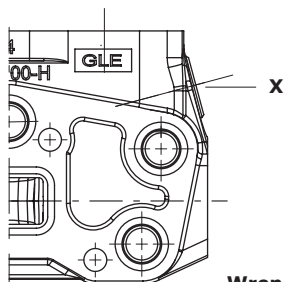

**Wrenches and tightening torques**  
 X = wrench 12 - 42 Nm (31 lbft)

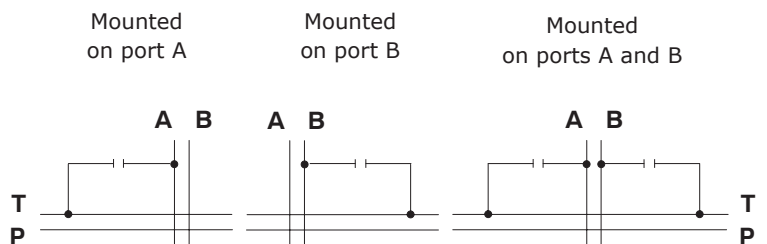



**Low leak valve**

For RPH5LL working port.

**Wrenches and tightening torques**

X = wrench 8 - 24 Nm (17.7 lbf<sup>t</sup>)

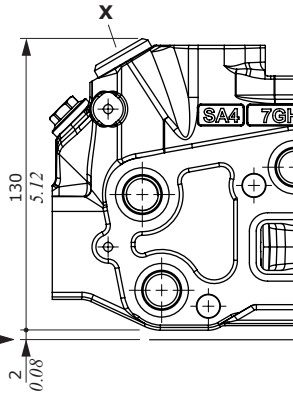

**Features**

Oil leakage . . . . . : 3-4 cm<sup>3</sup>/min (0.18-0.24 in<sup>3</sup>/min)  
 With mineral oil of 46mm<sup>2</sup>/s (46 cSt) viscosity at 40°C  
 (104°F) temperature

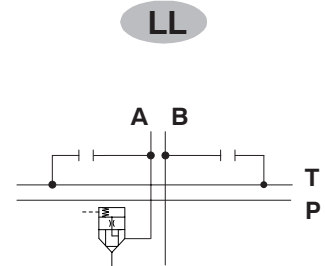

**Fixed setting antishock and anticavitation valves**

For RPH5LL, RPHT, RPH5, RPHSP, RSP5 working port.

**U 1 (100)**

Valve setting (bar)

- 1 mounted on A port
- 2 mounted on B port
- 3 mounted on A and B ports

**U1**

**U2**

**U3**

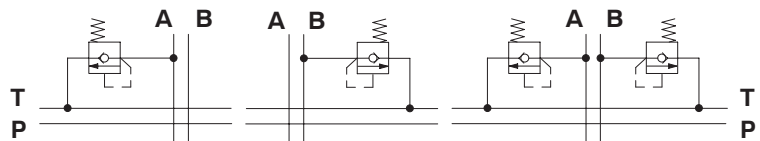

**Wrenches and tightening torques**

X = wrench 13 - 24 Nm (17.7 lbf<sup>t</sup>)

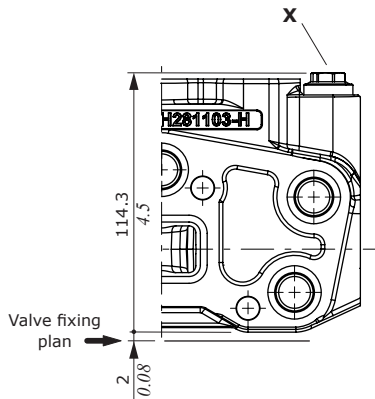

**Setting example**  
(10 l/min - 2.6 US gpm)

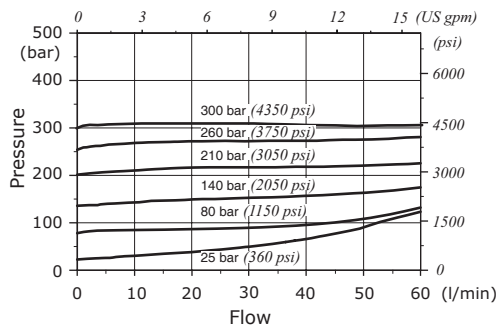

**Pressure drop**  
(in anticavitation)

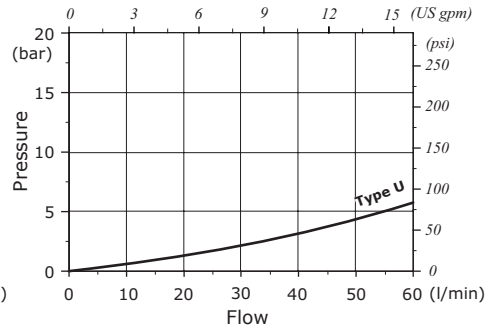

## Port valves

### Anticavitation valve

For RPH5LL, RPHT, RPH5, RPHSP, RSP5 working port.

#### C 1

- 1 mounted on A port
- 2 mounted on B port
- 3 mounted on A and B ports

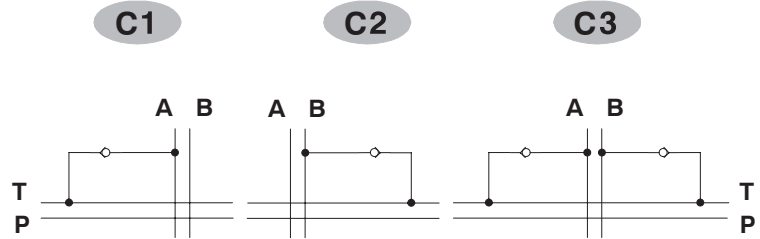

#### Wrenches and tightening torques

X = wrench 13 - 24 Nm (17.7 lbf<sub>t</sub>)

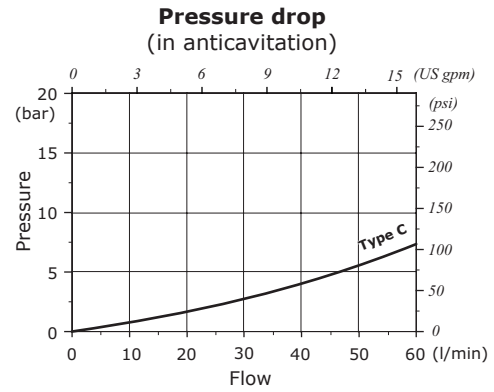
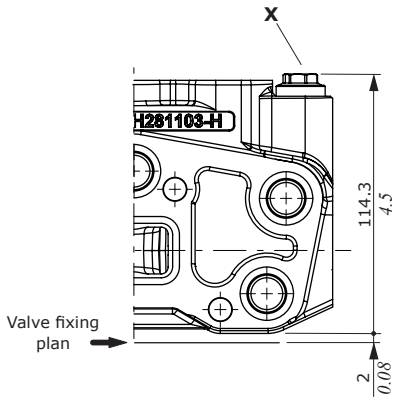

### Valve blanking plug

#### U 3 T

- 1 mounted on A port
- 2 mounted on B port
- 3 mounted on A and B ports

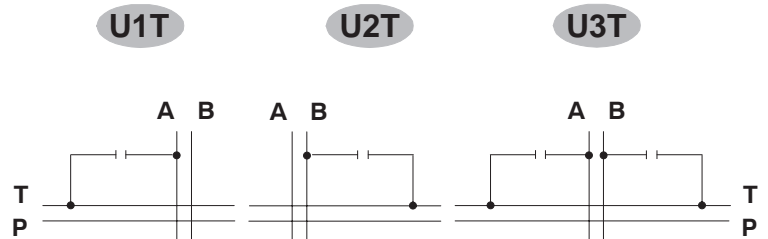

#### Wrenches and tightening torques

X = wrench 13 - 24 Nm (17.7 lbf<sub>t</sub>)

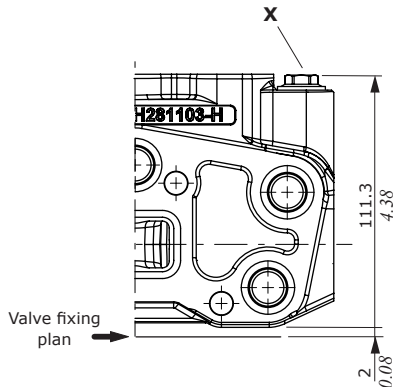

CS1 mid return manifold

Mid return manifolds for directional valve with left and right inlet both; they allow 2 independent circuits with common outlet.

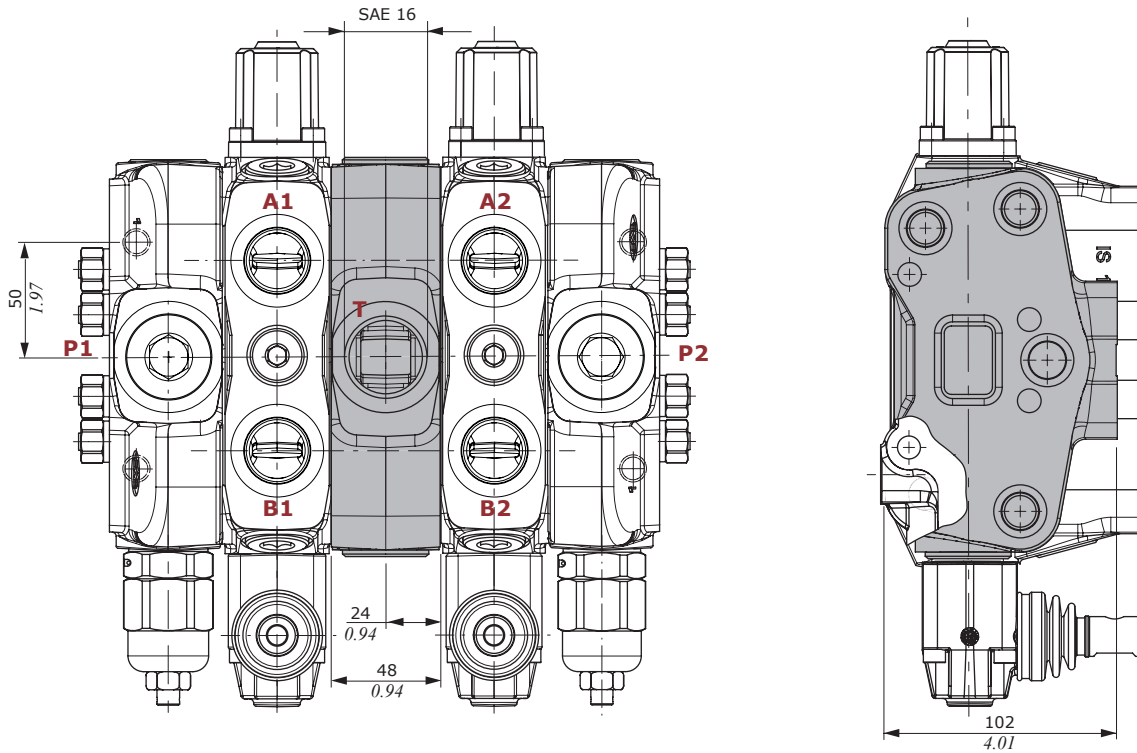

Hydraulic circuit

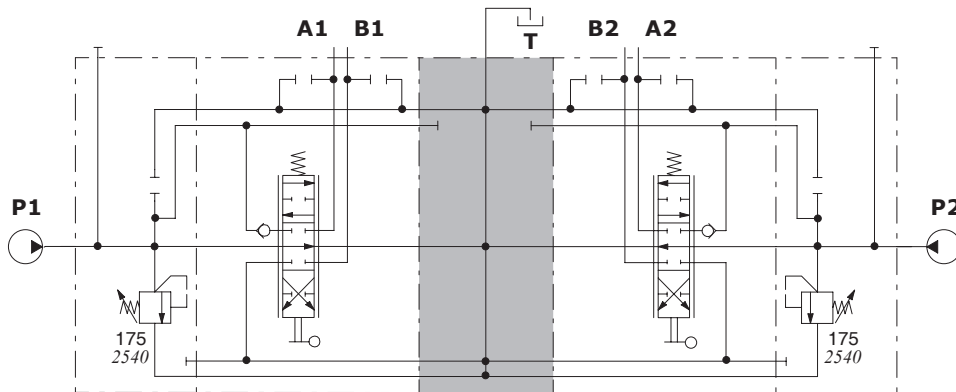

Description example:

SDS180/2/AC(YG3-175)/18L/CS1/ 18L/BC(YG3-175)-SAE

**CS3 mid return manifold**

Mid return manifolds for directional valves SDS180 with left inlet section and SDS150 with right inlet section; they allow 2 independent circuits with common outlet.

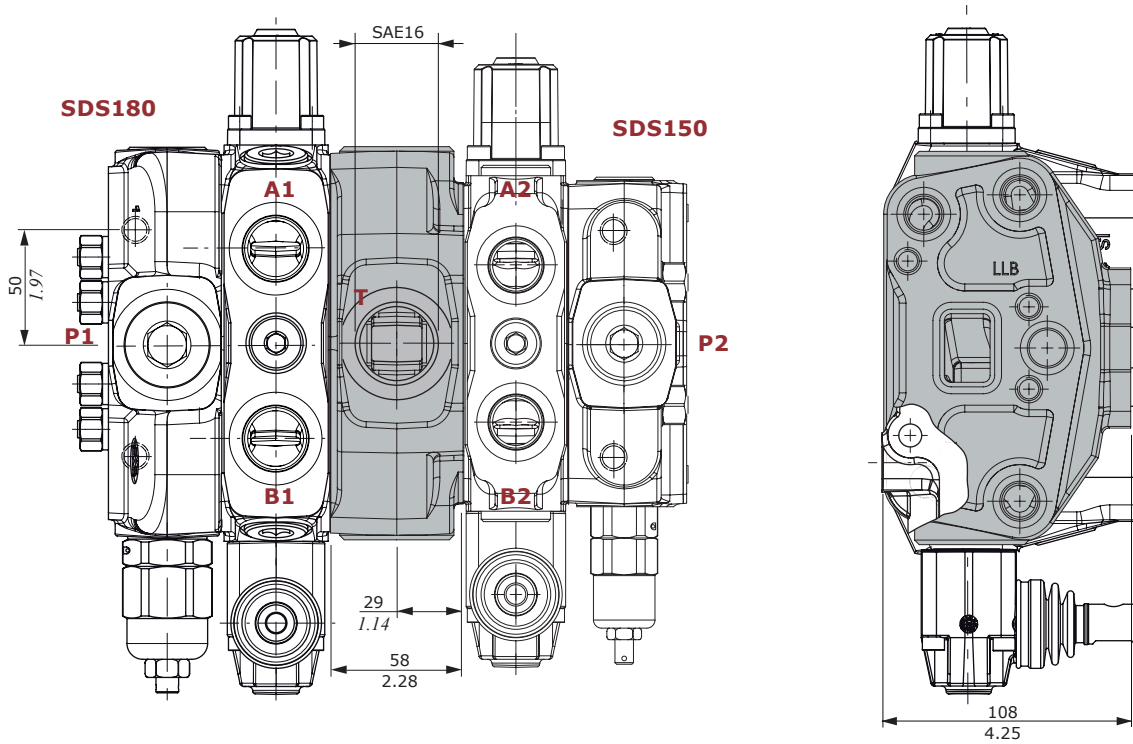

**Hydraulic circuit**

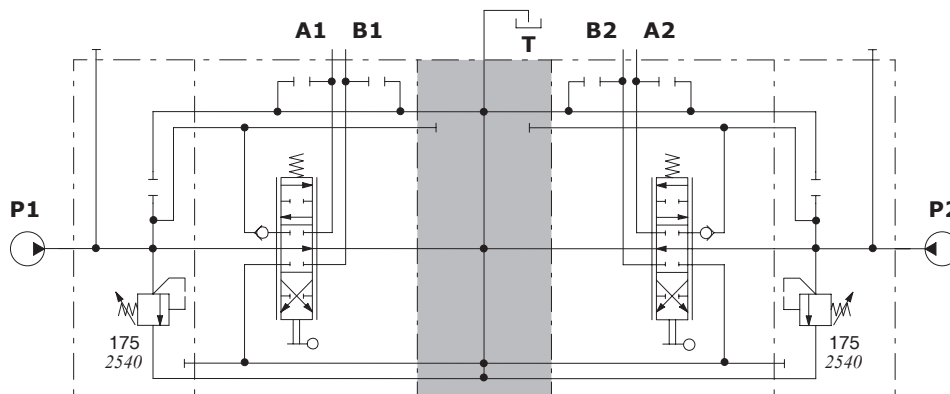

Description example:

SDS180/1/AC(YG3-175)/18L/CS3/18L/BC(YG3-175)/SDS150/1-SAE

**EI configuration**

The operation of up stream section exclude the EI downstream section.

The pressure of the downstream sections should be adjusted at least 20 bar below the relief valve setting.

Execution EI2, without plug, is prearranged for a second inlet.

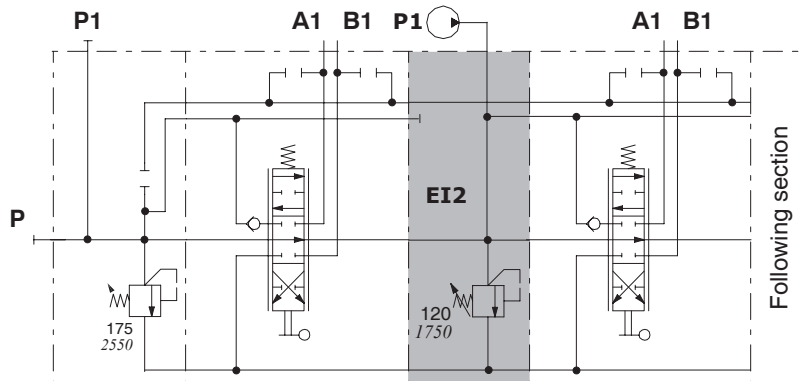
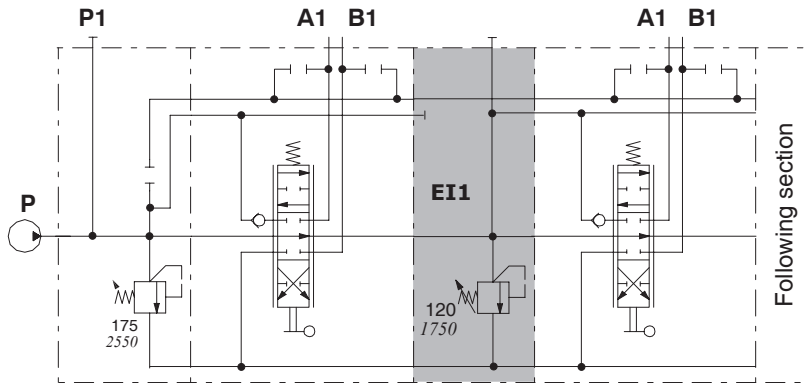
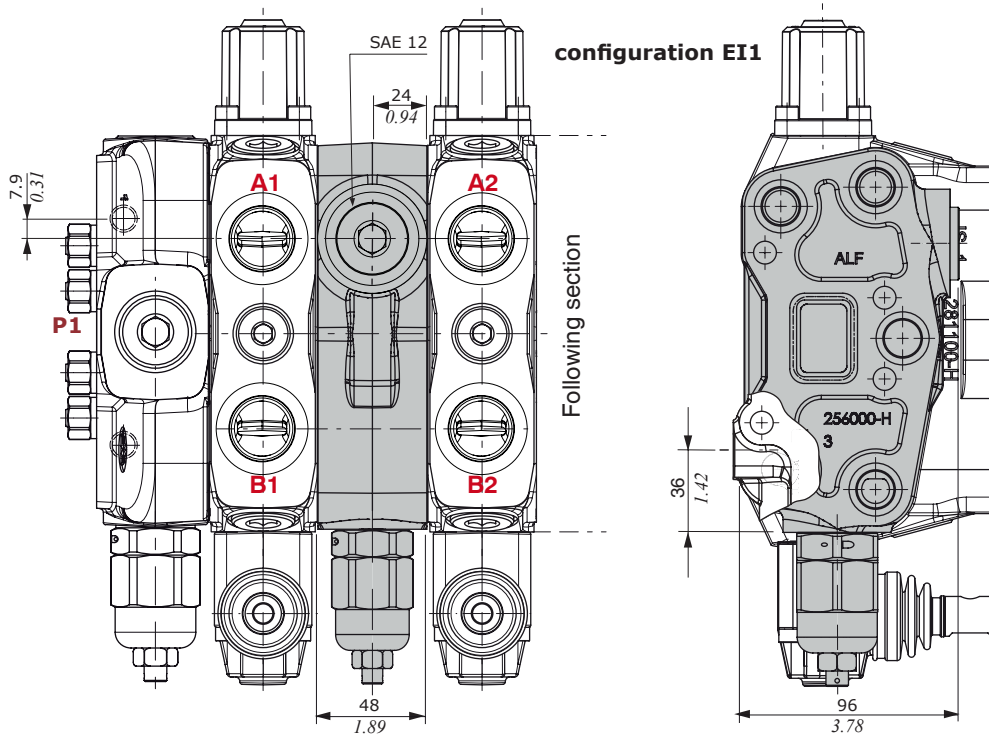

Service relief valve section

EIM configuration

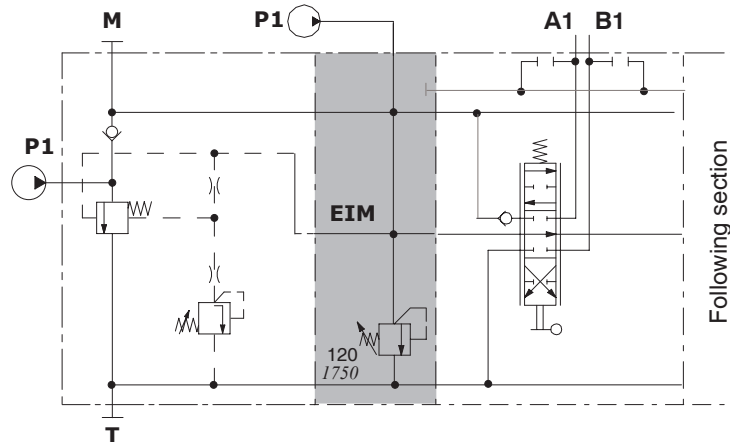
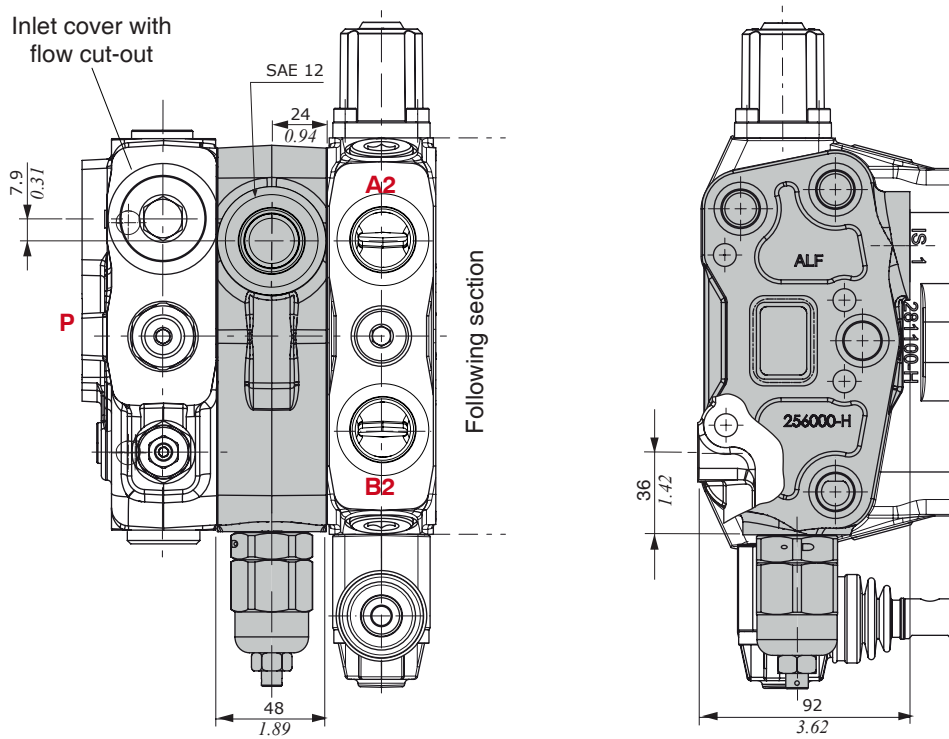

NOTE - EIM intermediate section must be always assembled with inlet cover with flow cut-out. (See page 20).

FS SDS180 / RC - SAE

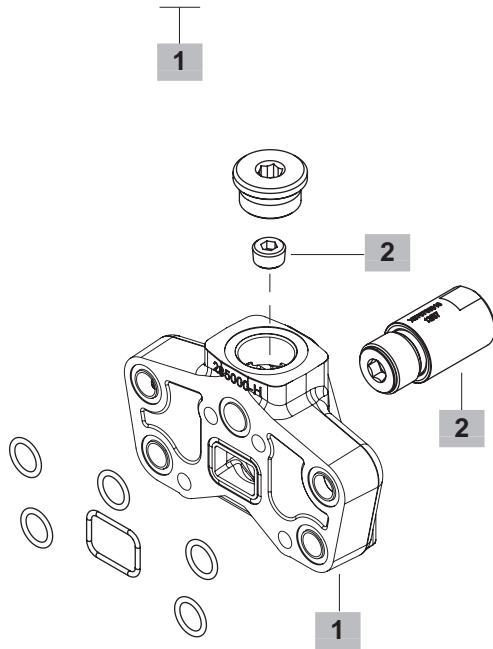

**1 Complete outlet cover**

TYPE	CODE	DESCRIPTION
<b>RC</b>	618305003	With side outlet
<b>RD</b>	618305009	With upper outlet
<b>RE</b>	618305001	With upper outlet and side carry-over sleeve
<b>RK</b>	618305004	With upper outlet and closed center
<b>RV</b>	618305014	With backpressure valve

**2 Circuit options**

TYPE	CODE	QTY	DESCRIPTION
-	4TAP318010	1	M18x1.5 tapered plug for carry-over (RE), carry-over with backpressure valve (RV) and closed centre (RK) options (see page 42)
<b>VRE</b>	X111072010	1	Backpressure valve 10 bar (145 psi) for RV configuration (see page 42)
-	3XTAP740210	1	Plug SAE 16

Dimensional data and hydraulic circuit

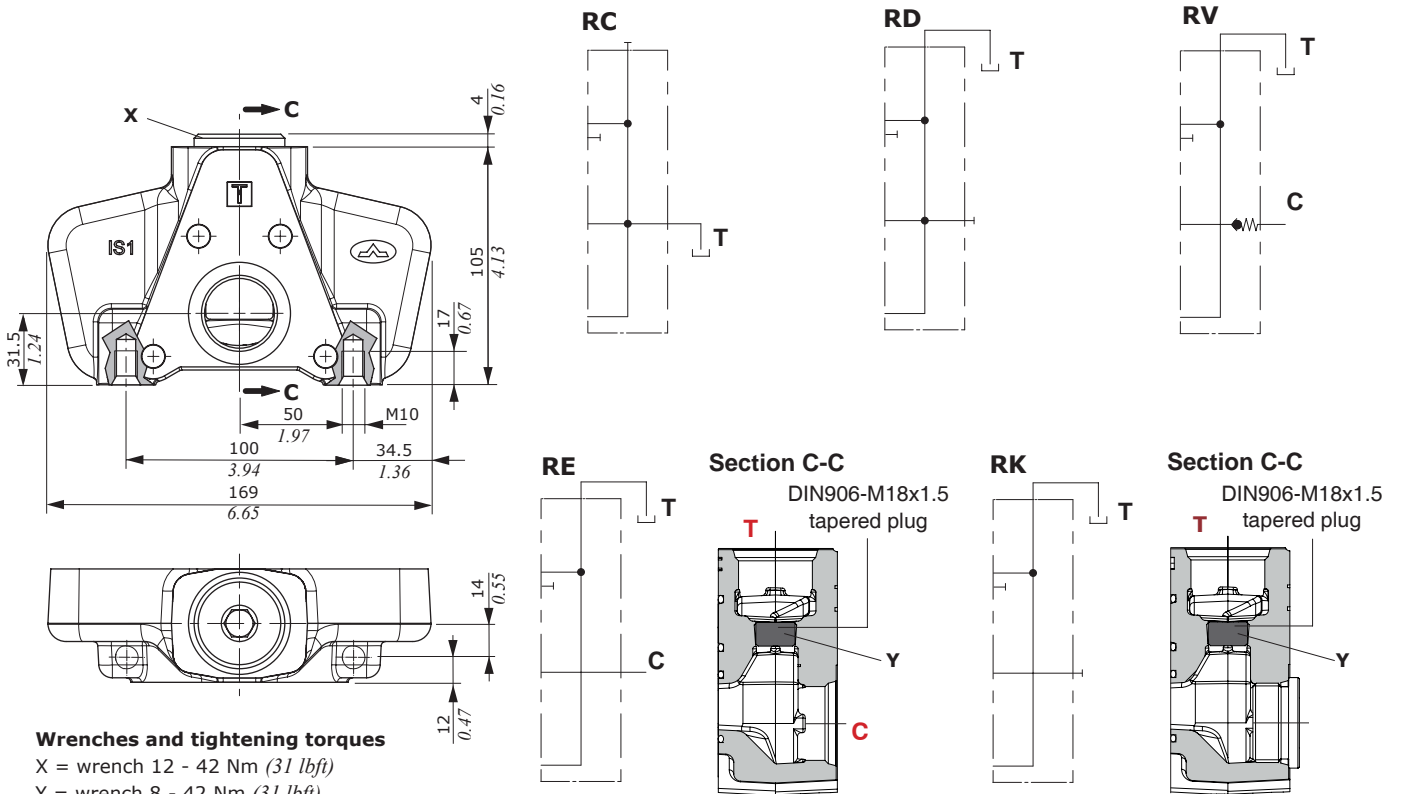

### Working conditions

This catalogue shows technical specifications and diagrams measured with mineral oil of 46mm<sup>2</sup>/s (46 cSt) viscosity at 40°C - 104°F temperature.

Nominal flow rating	on inlet P	180 l/min	47 US gpm
	on ports A and B	160 l/min	42 US gpm
Max pressure (¹)		315 bar	4600 psi
Standard stand by		14 bar	203 psi
Internal leakage (standard) A(B)⇒T	Δp = 100 bar - 1450 psi	5 cm <sup>3</sup> /min	0.30 in <sup>3</sup> /min
Fluid		Mineral based oil	
Fluid temperature	with NBR (BUNA-N) seals	from -20°C to 80°C	from -4°F to 176°F
	with FPM (VITON) seals	from -20°C to 100°C	from -4°F to 212°F
Viscosity	operating range	from 15 to 75 mm <sup>2</sup> /s	from 15 to 75 cSt
	min.	12 mm <sup>2</sup> /s	12 cSt
	max.	400 mm <sup>2</sup> /s	400 cSt
Max. contamination level		-/19/16 - ISO 4406	NAS 1638 - class 10
Ambient temperature for working conditions		from -40°C to 60°C	from -40°F to 140°F

NOTE - (¹) Intermittent pressure at max. 250,000 cycles with specific internal testing.

### Standard threads

REFERENCE STANDARD				
		BSP	UN-UNF	NPTF
THREAD ACCORDING TO		ISO 228/1	ISO 263	NSI B1.20.3
		BS 2779	ANSI B1.1 unified	
CAVITY DIMENSION ACCORDING TO	ISO	1179-1	11926-1	
	SAE		J1926-1	J476a
	DIN	3852-2 shape X or Y		

PORTS THREADING			
MAIN		BSP	UN-UNF
Inlet <b>P</b> - Outlet <b>T</b>		G 1	1 5/16-12 (SAE 16)
Ports <b>A</b> and <b>B</b>		G 3/4	1 1/16-12 (SAE 12)
Load sensing <b>LS</b>		G 1/4	9/16-18 (SAE 6)
PILOT			
Hydraulic		G 1/4	9/16-18 (SAE 6)



Dimensional data

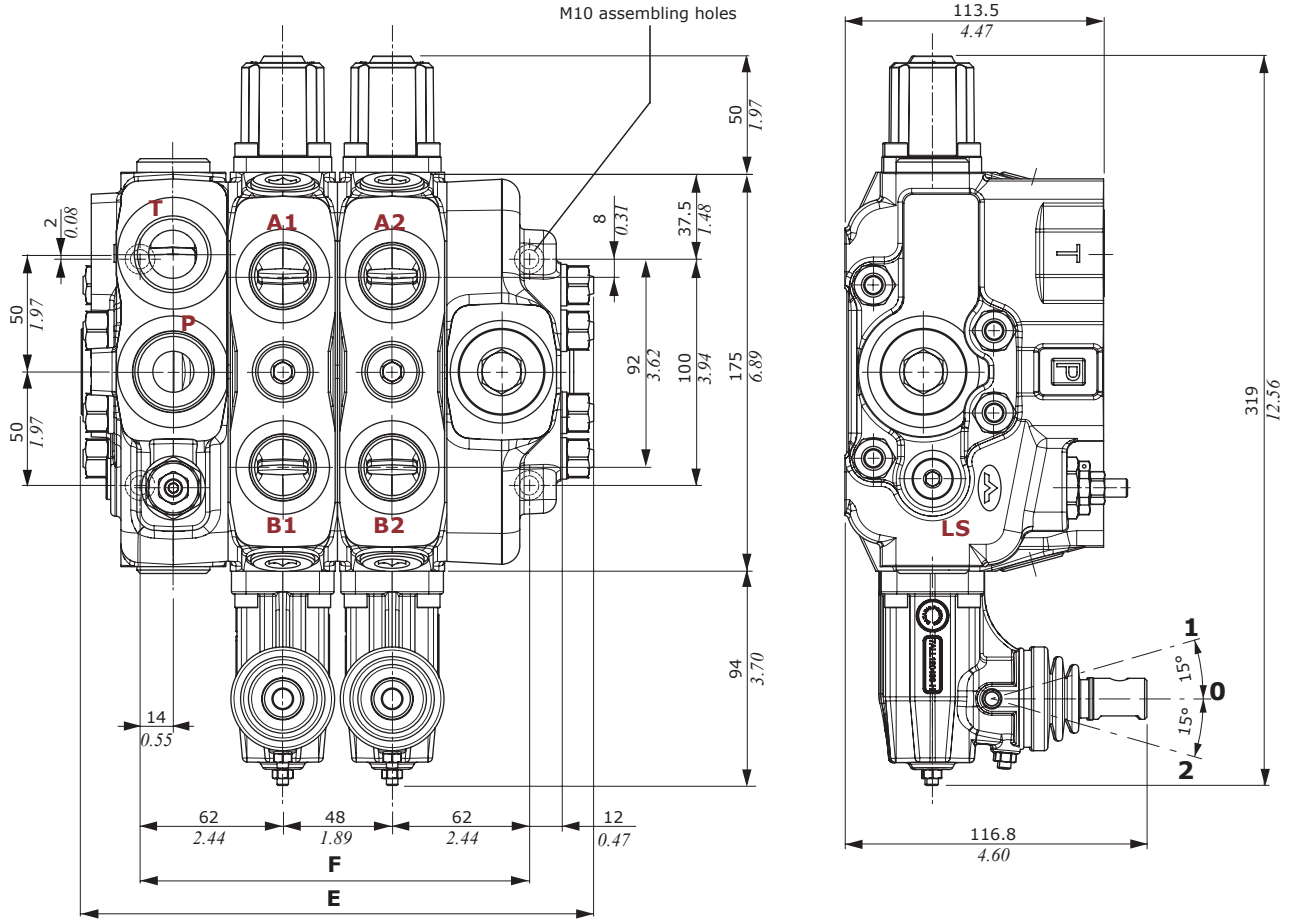

NOTE - Drawings and dimensions are referred to **BSP** thread configuration.

TYPE	E		F		Weight	
	mm	in	mm	in	Kg	lb
DLS180/1	177,8	7	124	4.88	13.8	30.42
DLS180/2	225,8	8.89	172	6.77	19.2	42.33
DLS180/3	273,8	10.78	220	8.66	24.6	54.23
DLS180/4	321,8	12.67	268	10.55	30	66.14
DLS180/5	369,8	14.56	316	12.44	35.4	78.04
DLS180/6	417,8	16.45	364	14.33	40.8	89.95

TYPE	E		F		Weight	
	mm	in	mm	in	Kg	lb
DLS180/7	465,8	18.34	412	16.22	46.2	101.85
DLS180/8	513,8	20.23	460	18.11	51.6	113.76
DLS180/9	561,8	22.12	508	20.00	57	125.66
DLS180/10	609,8	24	556	21.89	62.4	137.57
DLS180/11	657,8	25.90	604	23.78	67.8	149.47
DLS180/12	705,8	27.76	652	25.67	73.2	161.38

Performance data

P ⇒ T pressure drop

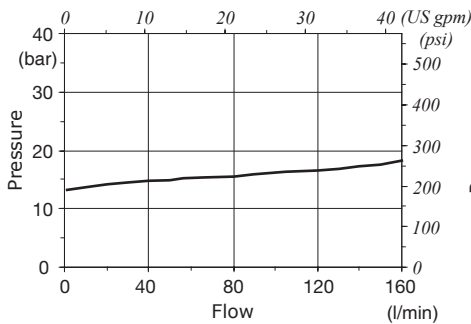

P ⇒ A(B) pressure drop

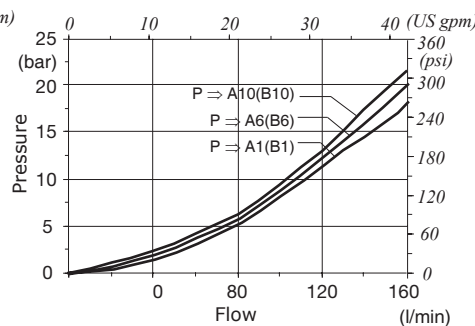

A(B) ⇒ T pressure drop

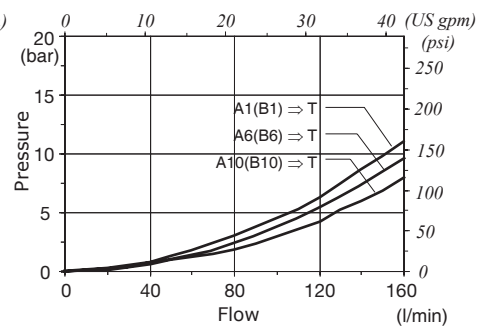

Hydraulic circuit

For open center circuit (fixed displacement pump)

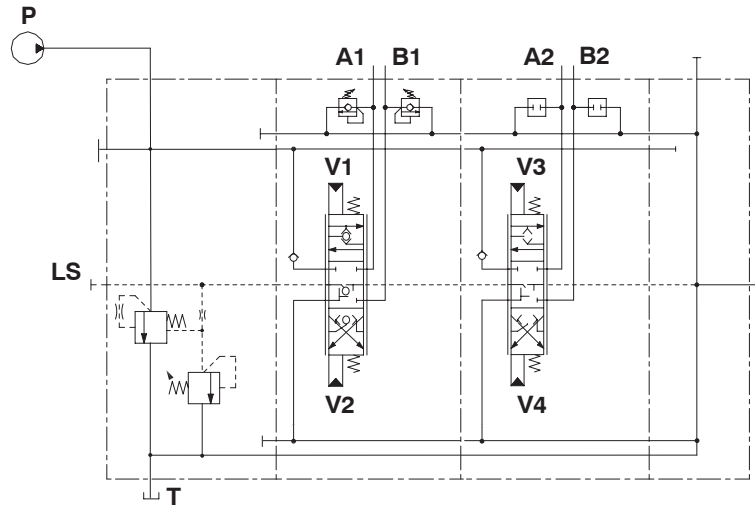

Description example:  
 SDS180/2/AMD(G4-210)/6ZM8IMF3.U3(G3-170)/6ZM8IMF3/RF-SAE

For closed center circuit (variable displacement pump with Load-Sensing compensator)

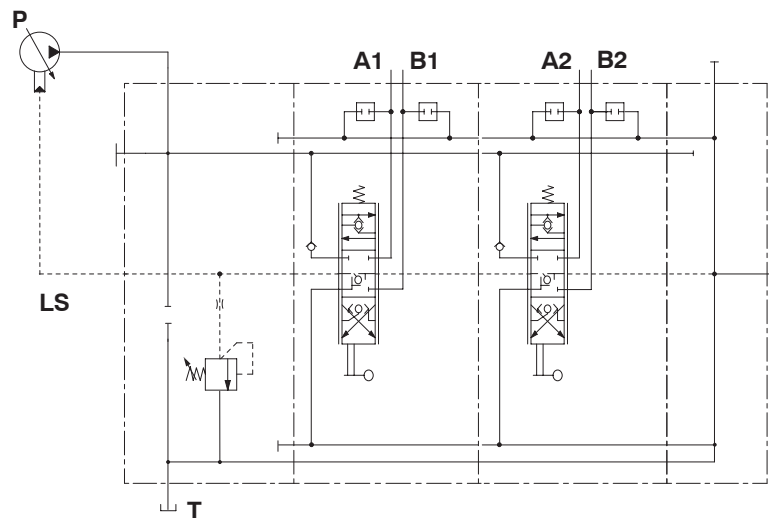

Description example:  
 SDS180/2/AND(G3-120)/6ZLF3/6ZLF3/RF-SAE

Complete sections ordering codes

DLS180 / 2 / AMD(G3-120) / 6ZLF3 / 6ZLF3 / RF - STAF

Nr. of working sections

1

2

3

4

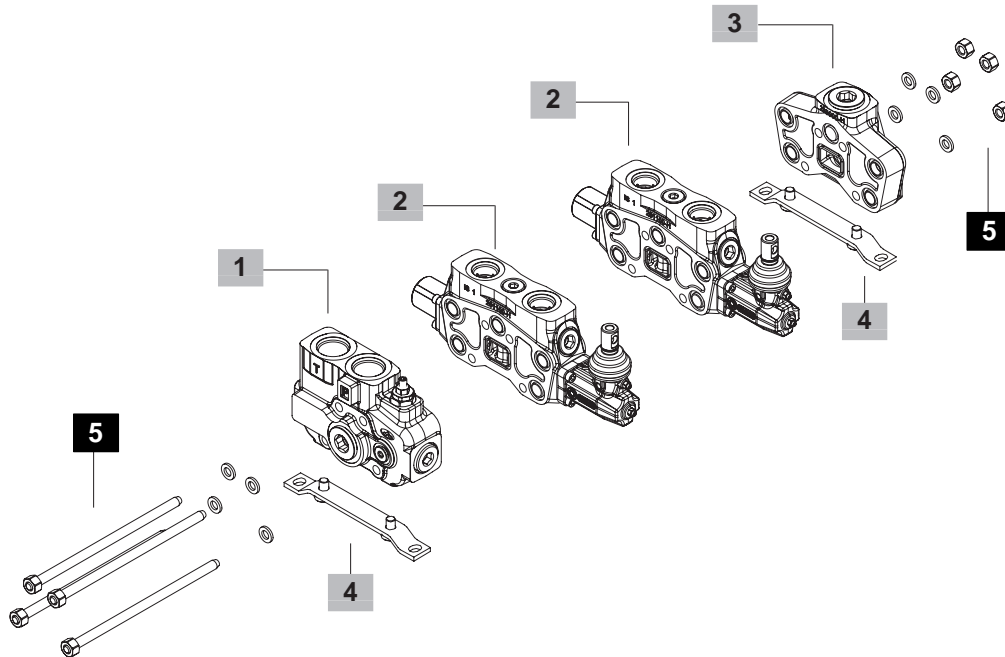

**1 Inlet section \*** page 68

TYPE	CODE	DESCRIPTION
<b>AMD(G3-120)</b>	61F371000	For open centre circuit, with L.S. pressure relief valve, upper inlet and outlet
<b>AMDT(G3-120)</b>	61F371004	As previous with upper outlet closed
<b>AND(G3-120)</b>	61F372000	For closed centre circuit, with L.S. pressure relief valve, upper inlet and outlet
<b>ANDT(G3-120)</b>	61F372003	As previous with upper outlet closed
<b>APD(SV)</b>	61F373000	Without compensator and L.S. pressure relief valve, upper inlet and outlet
<b>APDT(SV)</b>	61F373002	As previous with upper outlet closed

**2 Working section \*** page 70

TYPE	CODE	DESCRIPTION
<b>6Z8LF3</b>	61F171601	Parallel circuit, lever control
<b>6ZM8IMHF3</b>	61F171602	Parallel circuit, proportional hydraulic control with spool stroke limiter

**3 Outlet section \*** page 76

TYPE	CODE	DESCRIPTION
<b>RF</b>	618305006	With ports plugged
<b>RD</b>	618305009	With upper port plugged
<b>RC</b>	618305003	With side port plugged

**4 Fixing bracket** page 81

TYPE	CODE	DESCRIPTION
<b>STAF</b>	5STA125220	Brackets with fixing screws

**5 Assembling kit**

CODE	DESCRIPTION
5TIR110170	Tie rod kit for 1 working section directional valve
5TIR110218	Tie rod kit for 2 working sections directional valve
5TIR110266	Tie rod kit for 3 working sections directional valve
5TIR110316	Tie rod kit for 4 working sections directional valve
5TIR110368	Tie rod kit for 5 working sections directional valve
5TIR110410	Tie rod kit for 6 working sections directional valve
5TIR110458	Tie rod kit for 7 working sections directional valve
5TIR110506	Tie rod kit for 8 working sections directional valve
5TIR110554	Tie rod kit for 9 working sections directional valve
5TIR110602	Tie rod kit for 10 working sections directional valve
5TIR110650	Tie rod kit for 11 working sections directional valve
5TIR110698	Tie rod kit for 12 working sections directional valve

NOTE (\*) - Codes are referred to **UN-UNF** thread.

## Parts ordering codes

FE DLS180 / AM D T (G3 - 120)

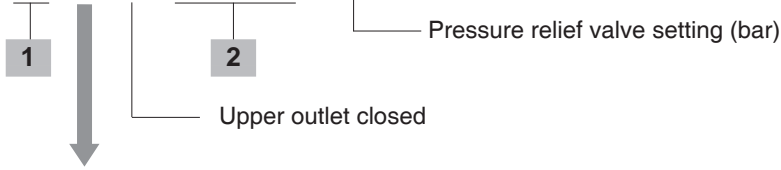

### Available configurations

- D: With upper inlet
- C: With side inlet

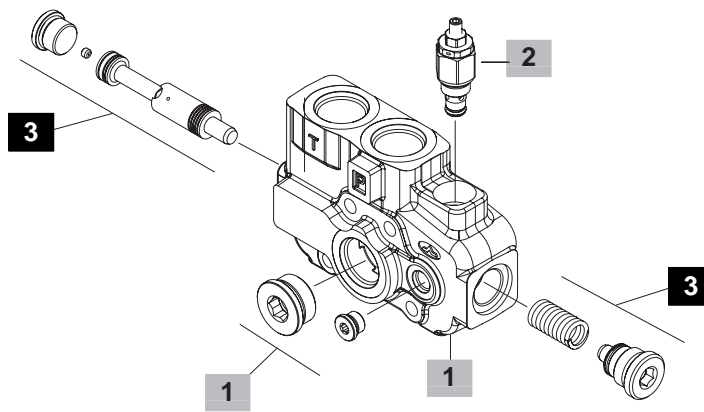

### 1 Inlet cover body \* page 67

TYPE	CODE	DESCRIPTION
AM	5FIA318700	For fixed displacement pump, L.S. compensator (open centre) with main relief valve arrangement
AN	5FIA318701	For variable displacement pump, (closed centre) with main relief valve arrangement
AP	5FIA318702	For variable displacement pump, (closed centre) without main relief valve predisposition

### 3 Compensator kit

CODE	DESCRIPTION
5KIT018300	Compensator kit, for AM inlet cover
5KIT018310	Compensator blanking kit, for AN and AP inlet covers

### 2 Main relief valve page 21

Standard setting is referred to 10 l/min (2.6 US gpm) flow.

TYPE	CODE	DESCRIPTION
LSW(G2)	5KIT118110	Range 5-50 bar (72-720 psi) standard setting 30 bar (400 psi)
LSW(G3)	5KIT118111	Range 50-220 bar (720-3200 psi) standard setting 150 bar (2150 psi)
LSW(G4)	5KIT118112	Range 180-315 bar (2600-4550 psi) standard setting 250 bar (3600 psi)
SV	XTAP525320	Relief valve blanking plug

NOTE (\*) - Codes are referred to **UN-UNF** thread.

Dimensional data and hydraulic circuit

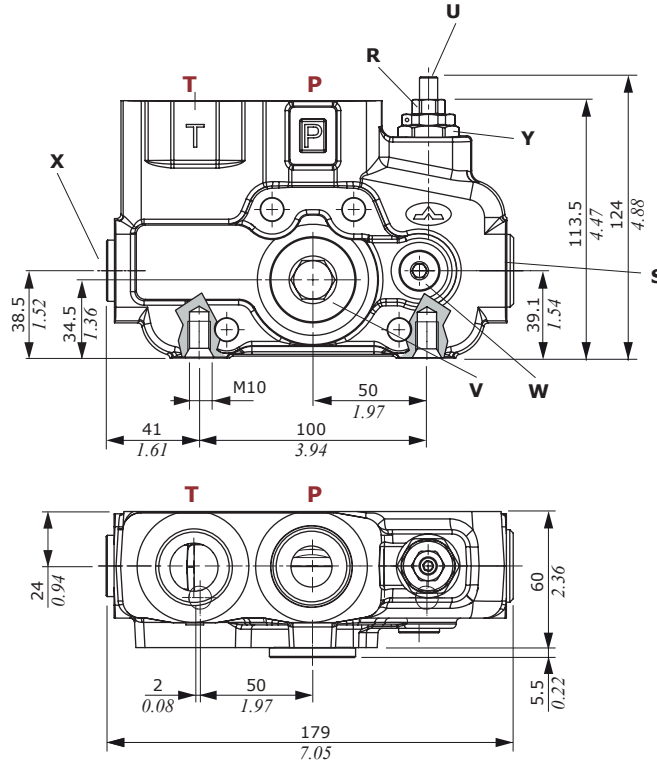

**Wrenches and tightening torques**

- X = wrench 10 - 24 Nm (17.7 lbf<sup>t</sup>)
- Y = wrench 24 - 30 Nm (22.13 lbf<sup>t</sup>)
- W = wrench 6 - 24 Nm (17.7 lbf<sup>t</sup>)
- V = wrench 12 - 42 Nm (31 lbf<sup>t</sup>)
- U = allen wrench 4
- R = allen wrench 13
- S = wrench 12 - 42 Nm (31 lbf<sup>t</sup>)

For fixed displacement pump, L.S. compensator (open centre) with main relief valve

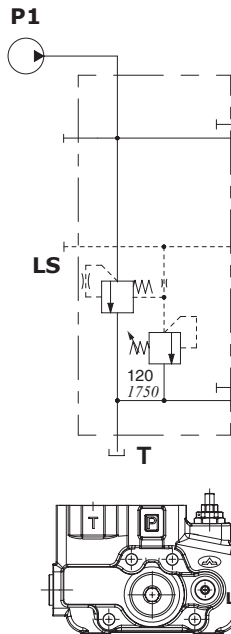

Description example:  
**AMD(G3-120)**

For variable displacement pump, (closed centre) with main relief valve

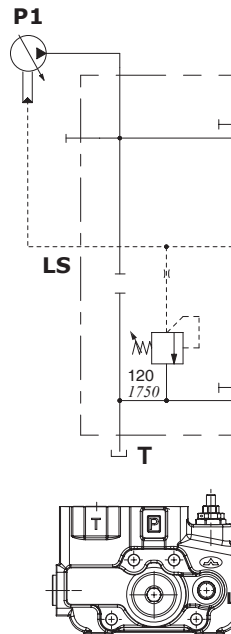

Description example:  
**AND(G3-120)**

For variable displacement pump, (closed centre) without main relief valve

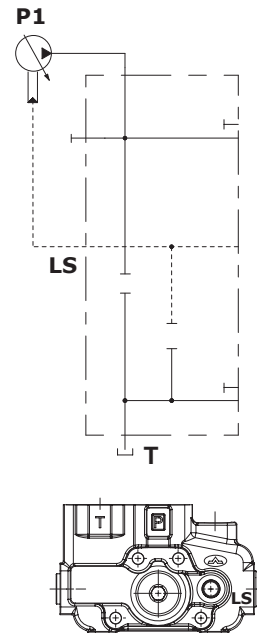

Description example:  
**APD(SV)**

## Parts ordering codes (mechanical control)

EL DLS180 / 6Z 8 LF3 P1 (G3 - 100)

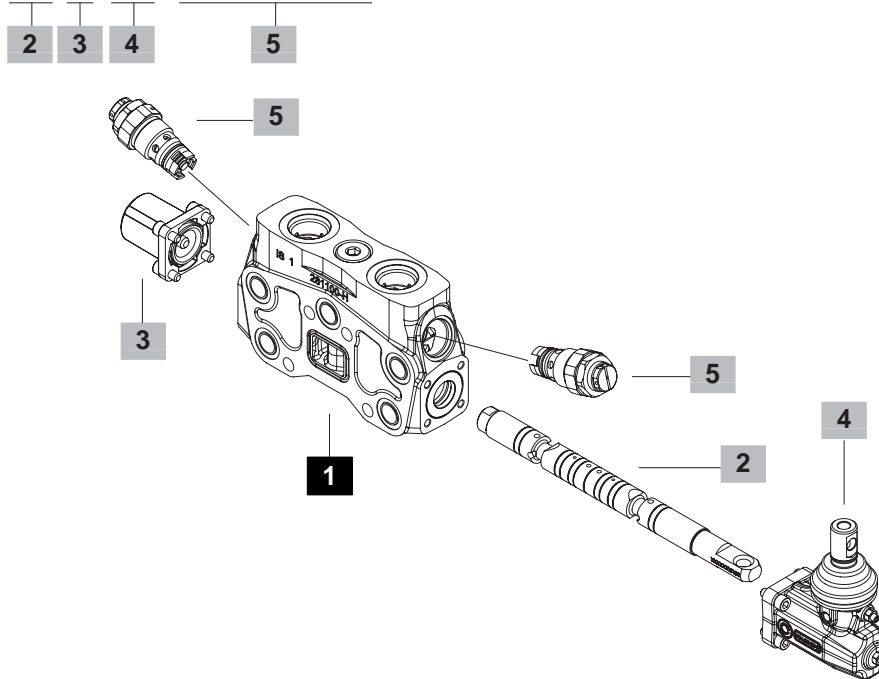

### 1 Working section kit \* page 72

TYPE	CODE	DESCRIPTION
P	5EL5187000	Parallel circuit for hydraulic controls

### 2 Spools page 72

TYPE	CODE	DESCRIPTION
<b>Double acting, 3 positions, with A and B closed in neutral position.</b>		
6Q	3CU3610040	Up to 40 l/min (10.57 Us gpm) flow
6O	3CU3610080	Up to 80 l/min (21.13 Us gpm) flow
6V	3CU3610120	Up to 120 l/min (31.70 Us gpm) flow
6Z	3CU3610140	Up to 140 l/min (36.98 Us gpm) flow
<b>Double acting, 3 positions, with A and B to tank in neutral position.</b>		
7V	3CU3625120	Up to 120 l/min (31.70 Us gpm) flow
7Z	3CU3625140	Up to 140 l/min (36.98 Us gpm) flow

### 3 "A" side spool positioners page 73

TYPE	CODE	DESCRIPTION
7FT	5V07210100	With friction and notch for neutral position sensor
11B	5V11210000	Detent in positions 1 and 2 and spring return in neutral position
8IZ	5V08110800	Proportional hydraulic control
8MC	5V08210000	With spring return in neutral position (see page 36)
9BZ	5V09110030	With detent in position 1 and spring return in neutral position (see page 37)
10BZ	5V10110030	With detent in position 2 and spring return in neutral position (see page 37)
11BZ	5V11110030	Detent in positions 1 and 2 and spring return in neutral position (see page 37)

### 4 "B" side options page 74

TYPE	CODE	DESCRIPTION
L	5LEV110110-H	Standard lever box
LF3	5LEV110115-H	Lever box with spool stroke limiter
LA	5LEV110125-H	Steel lever kit
LAF3	5LEV110120-H	Steel lever kit with spool stroke limiter
SLP	5COP110000	Without lever box, with dust-proof plate
TQ	5TEL118100-H	Flexible cable connection; for CD cables

### 5 Adjustable port valves page 53

Valves standard setting is referred to 10 l/min (2.64 USgpm) flow.

TYPE	CODE	DESCRIPTION
-	XTAP530361	Valve blanking plug (omitted in description)
C	3XCAR416100	Anti-cavitation valve
<b>Anti-shock valve</b>		
P(G2)	XCAR216115	Range 50-120 bar (725-1750 psi) standard setting 63 bar (900 psi)
P(G3)	XCAR216116	Range 100-250 bar (1450-3600 psi) standard setting 100 bar (1450 psi)
P(G4)	XCAR216117	Range 160-315 bar (2300-4600 psi) standard setting 200 bar (2900 psi)
<b>Pilot hydraulic unloader valve</b>		
PX	XCAR416301	Pilot hydraulic unloader valve
<b>Anti-shock and anti-cavitation valve</b>		
U(G2)	X011411099	Range 35-90 bar (510 -1300 psi) standard setting 60 bar (870 psi)
U(G3)	X011411100	Range 100-250 bar (1450-3600 psi) standard setting 100 bar (1800 psi)
U(G4)	X011411101	Range 180-350 bar (2600-5100 psi) standard setting 200 bar (2900 psi)
<b>Pilot operated anti-shock and anti-cavitation valve</b>		
UXW(G)	X01141B160	Range 63-315 bar (900-4600 psi) standard setting 160 bar (2300 psi)

NOTE (\*) - Codes are referred to UN-UNF thread.

Parts ordering codes (proportional hydraulic control)

EL DLS180 / 6ZM 8IMF3 P1 (G3 - 100)

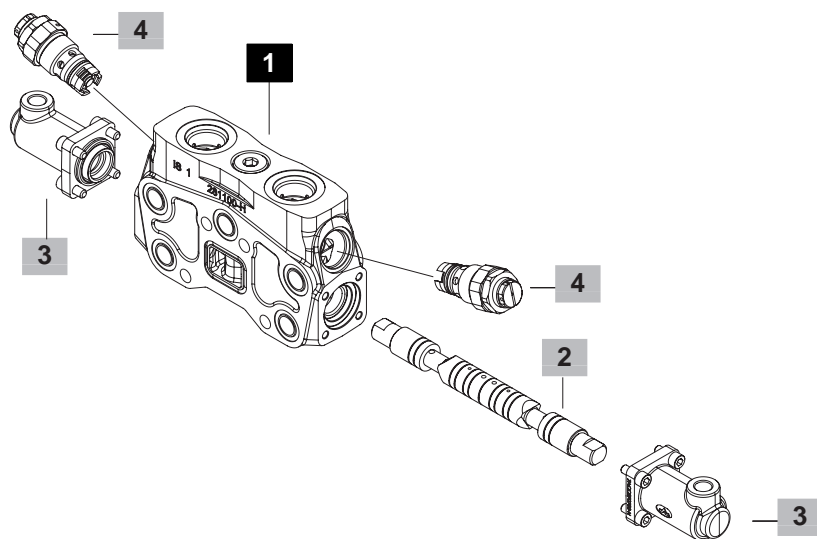

**1 Working section kit \*** page 72

TIPO	CODE	DESCRIPTION
<b>P(IM)</b>	5EL5187000A	Parallel circuit for hydraulic controls

**2 Spools** page 72

TYPE	CODE	DESCRIPTION
<b>Double acting, 3 positions, with A and B closed in neutral position.</b>		
<b>6QM</b>	3CU3550040	Up to 40 l/min (10.57 US gpm) flow
<b>6OM</b>	3CU3550080	Up to 80 l/min (21.13 US gpm) flow
<b>6VM</b>	3CU3550120	Up to 120 l/min (31.70 US gpm) flow
<b>6ZM</b>	3CU3550140	Up to 140 l/min (36.98 US gpm) flow
<b>Double acting, 3 positions, with A and B to tank in neutral position.</b>		
<b>7VM</b>	3CU3555120	Up to 120 l/min (31.70 US gpm) flow
<b>7ZM</b>	3CU3555140	Up to 140 l/min (36.98 US gpm) flow

**3 Complete controls \*** page 75

<b>Proportional Hydraulic control</b>		
TYPE	CODE	DESCRIPTION
<b>8IMOH</b>	5IDR216702-H	Steel control. Range 5.8-19 bar (84-270 psi)
<b>8IMOHF3</b>	5IDR216711-H	Steel control with stroke limiters. Range 5.8-19 bar (84-270 psi)

**4 Adjustable port valves** page 53

See page 70.

NOTE (\*) - Codes are referred to **UN-UNF** thread.

Dimensional data and hydraulic circuit

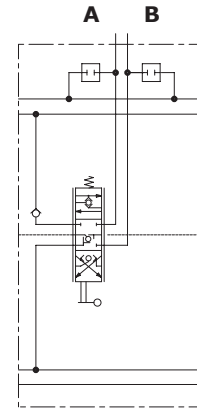
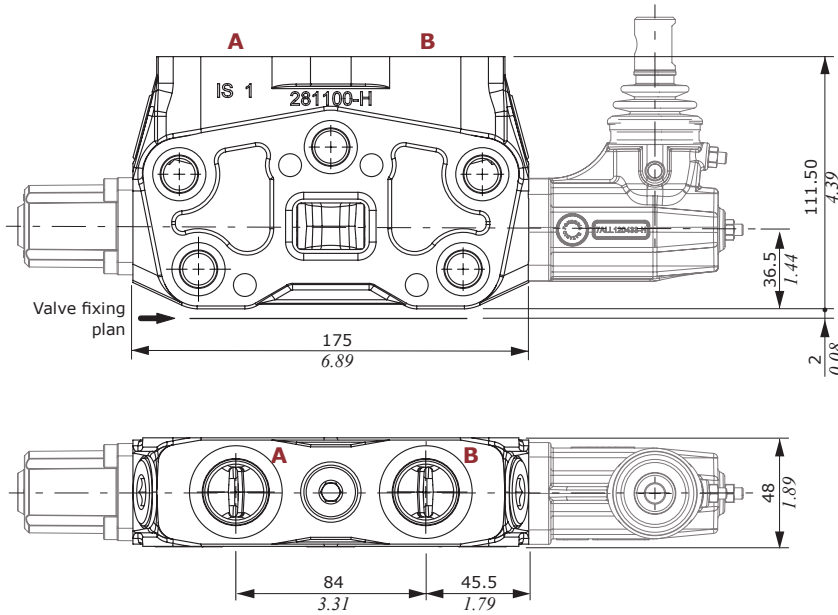

Description example:  
**6Z8LF3**

Spools

**Type 6Q/6O/6V/6Z spool**

Double acting, 3 positions, with A and B closed in neutral position

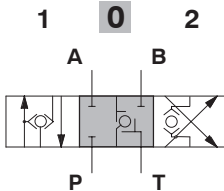

**Spool stroke**

position 1: + 7 mm (+ 0.28 in)  
position 2: - 7 mm (- 0.28 in)

**Type 7V/7Z spool**

Double acting, 3 positions, with A and B to tank in neutral position

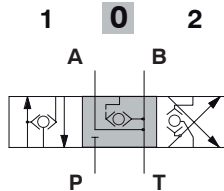

**Spool stroke**

position 1: + 7 mm (+ 0.28 in)  
position 2: - 7 mm (- 0.28 in)



"A" side spool positioners

For "A" side spool positioners 9BZ, 10BZ and 11BZ see page 37

**7FT type**

With friction.

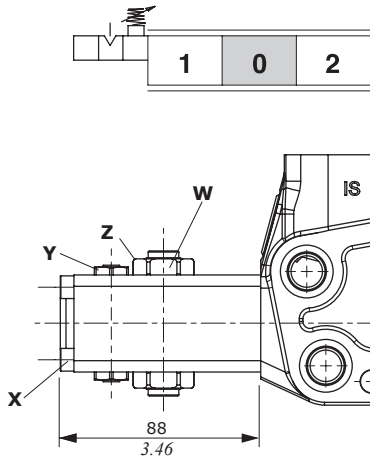

**Wrenches and tightening torques**

- Z = wrench 24 - manual tightening
- X = wrench 5 - 9.8 Nm (7.23 lbft)
- Y = wrench 15 - 42 Nm (31 lbft)
- W = allen wrench 4

**8MC type**

Spring return.

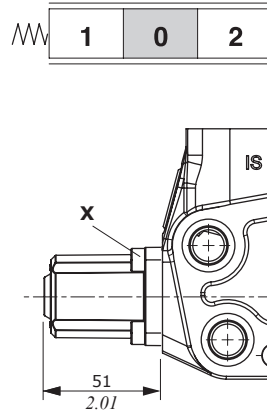

**Wrenches and tightening torques**

- X = wrench 5 - 6.6 Nm (4.87 lbft)

**11B type**

Detent in positions 1 and 2, spring return in neutral position.

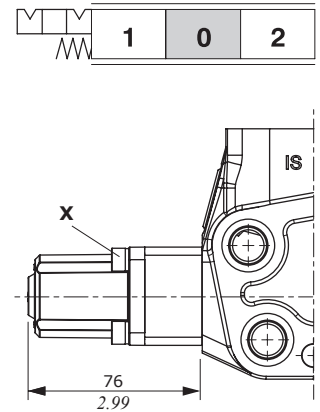

**Wrenches and tightening torques**

- X = wrench 5 - 6.6 Nm (4.87 lbft)

**8IZ**

Proportional hydraulic control.

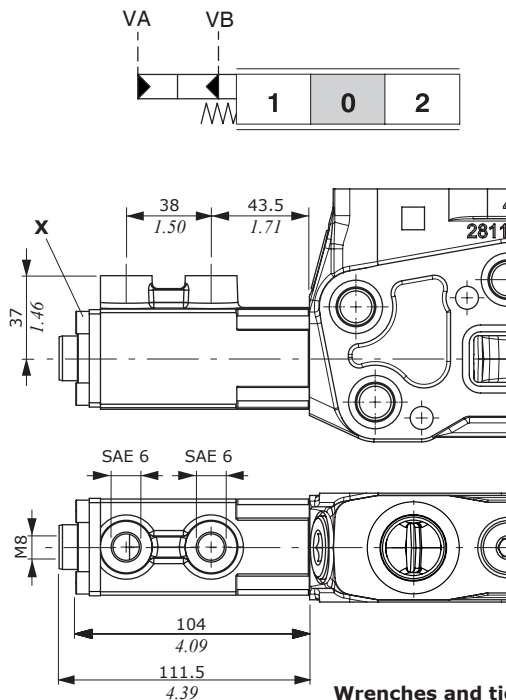

**Wrenches and tightening torques**

- X = wrench 5 - 9.8 Nm (7.23 lbft)

**Pressure - stroke diagram**

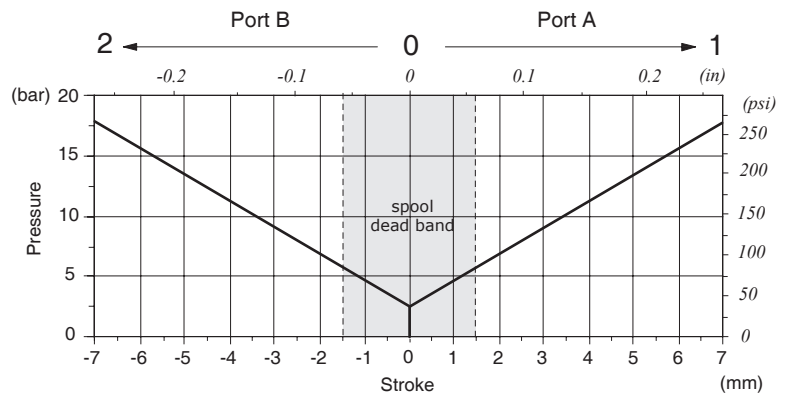

**Features**

- Adjustment range . . . . . : From 5 to 22 bar (from 72.5 to 320 psi)
- Pilot pressure . . . . . : max. 100 bar (1450 psi)

## "B" side options

### Lever control

#### L type

Aluminium pivot box with protective rubber bellows.

##### Wrenches and tightening torques

X = wrench 5 - 9.8 Nm (7.23 lbf<sub>t</sub>)

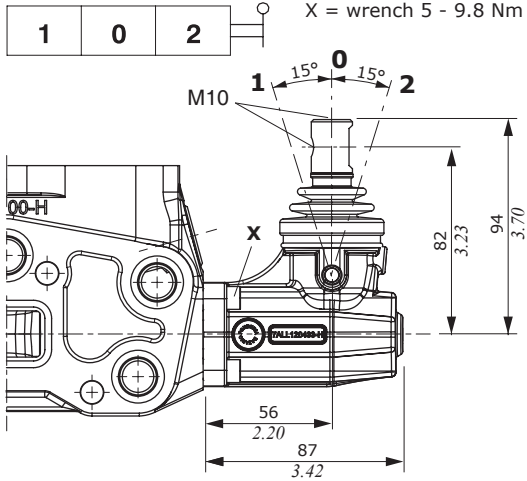

#### LF3 type

With spool stroke adjustments in pos.1 and 2, (P→A), (P→B).

##### Wrenches and tightening torques

X = wrench 5 - 9.8 Nm (7.23 lbf<sub>t</sub>)

Y = wrench 8 - 6.6 Nm (4.87 lbf<sub>t</sub>)

Z = allen wrench 2.5

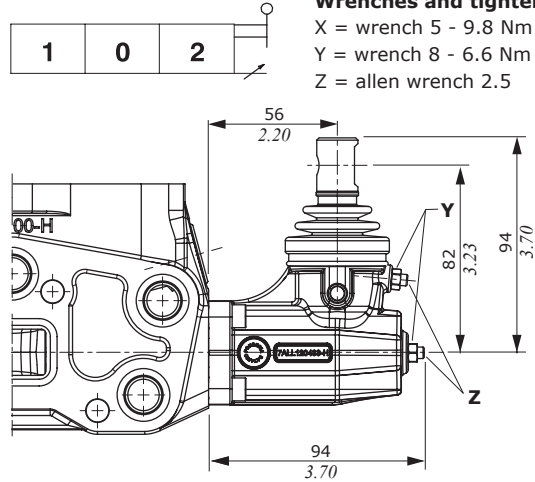

#### LA type

Steel execution.

##### Wrenches and tightening torques

X = wrench 5 - 9.8 Nm (7.23 lbf<sub>t</sub>)

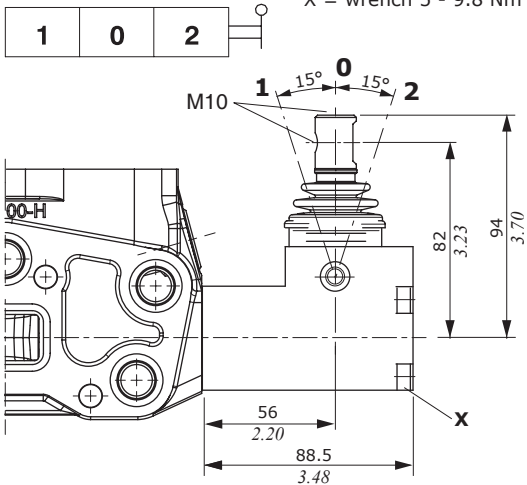

#### LAF3 type

Steel execution with spool stroke adjustments in pos.1 and 2, (P→A), (P→B).

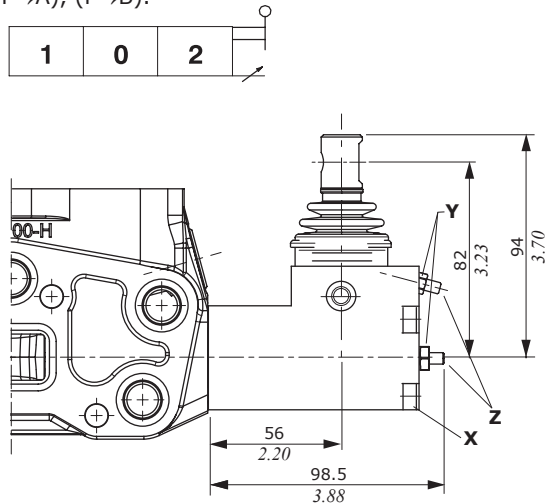

#### SLP type

Mechanical control with dust-proof plate kit.

##### Wrenches and tightening torques

X = wrench 5 - 9.8 Nm (7.23 lbf<sub>t</sub>)

##### Wrenches and tightening torques

X = wrench 5 - 9.8 Nm (7.23 lbf<sub>t</sub>)

Y = wrench 8 - 6.6 Nm (4.87 lbf<sub>t</sub>)

Z = allen wrench 2.5

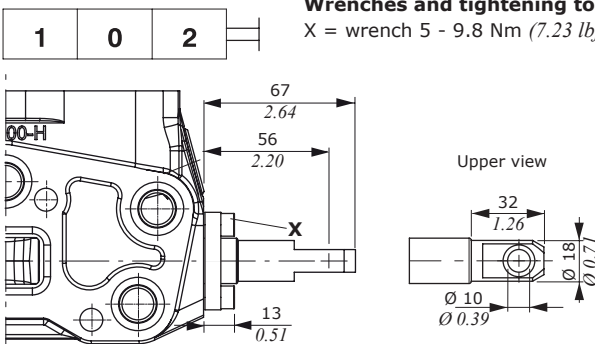

**TQ cable remote control kit**

For remote control with flexible cable.

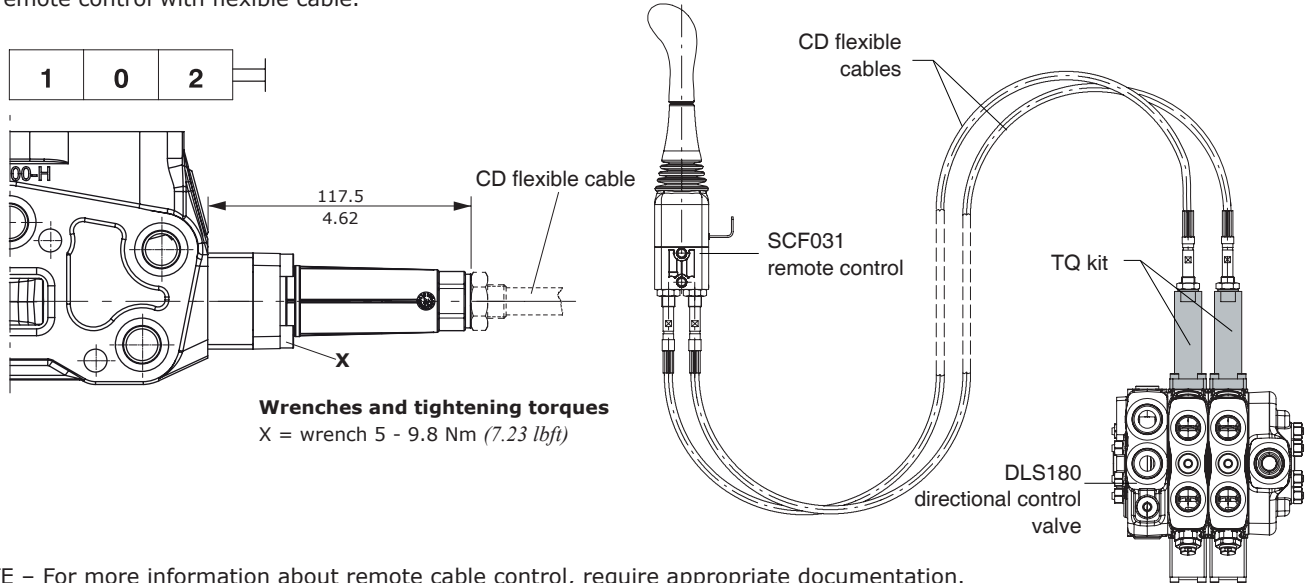

NOTE – For more information about remote cable control, require appropriate documentation.

**Complete controls**

**8IMOHF3 proportional hydraulic kit**

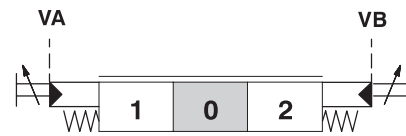
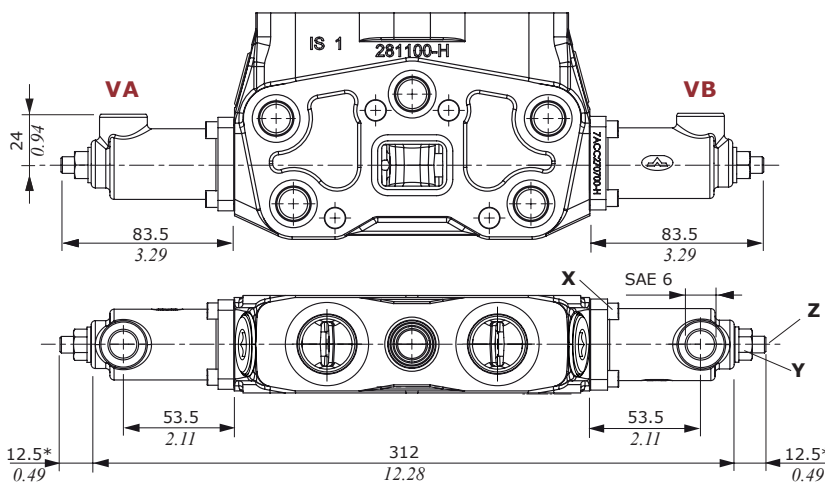

**8IMOHF3 type features**

Adjustment range . . . . . : from 5.8 to 19 bar  
(from 84.1 to 275 psi)  
see curve type 033

Pilot pressure . . . . . : max. 100 bar  
(1450 psi)

**Wrenches and tightening torques**

X = wrench 5 - 9.8 Nm (7.23 lbft)  
Y = wrench 13 - 24 Nm (17.7 lbft)  
Z = allen wrench 4

\* depends on stroke setting

**Pressure - stroke diagram**

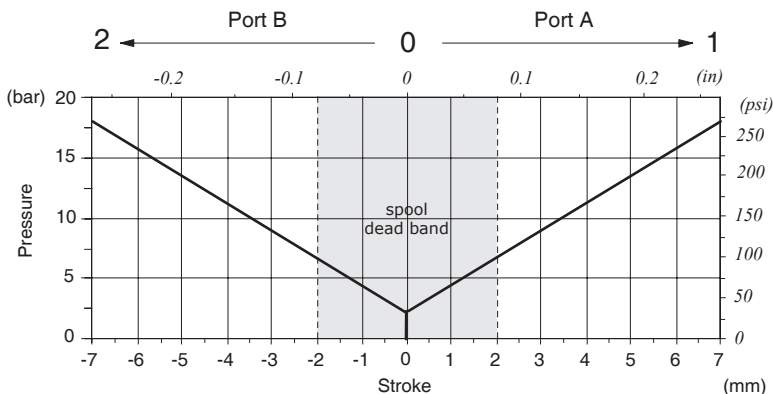

**Pressure control curve on VA and VB ports: type 033**

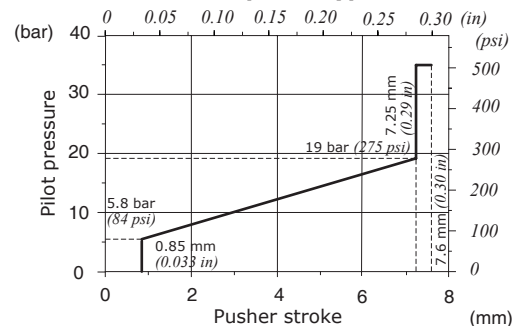

NOTE – For 8IMOH complete controls see page 49

## Dimensional data and hydraulic circuit

**RF type**  
with ports plugged

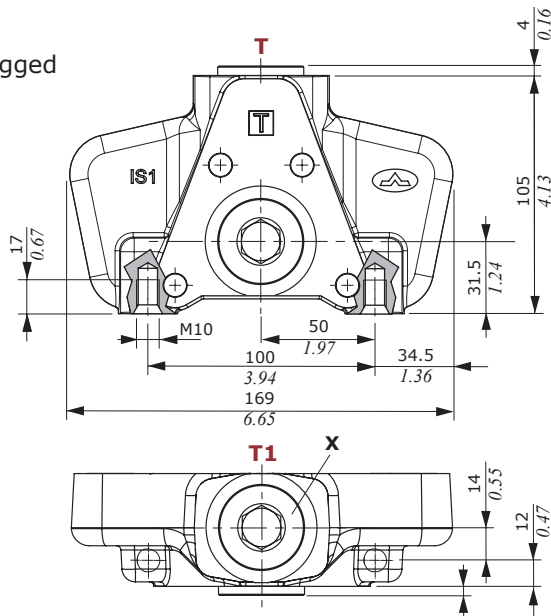

**Wrenches and tightening torques**  
X = wrench 12 - 42 Nm (31 lbf<sub>t</sub>)

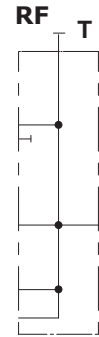

**With RD type**  
upper outlet

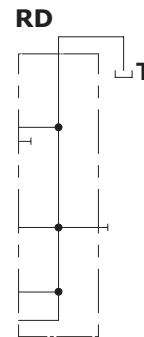
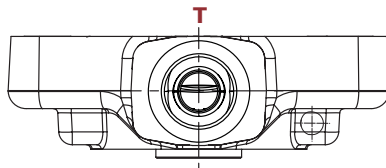

**With RC type**  
side outlet

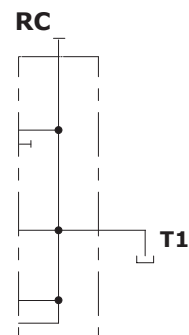
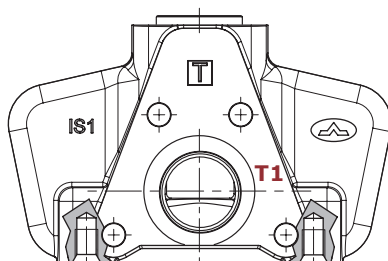

## Installation and maintenance

The SDS180 and DLS180 valve are assembled and tested as per the technical specification of this catalogue.

Before the final installation on your equipment, follow the below recommendations:

- the valve can be assembled in any position; order to prevent working section deformation and spool sticking mount the product on a flat surface;
- In order to prevent the possibility of water entering the lever box and spool control kit, do not use high pressure wash down directly on the valve;
- prior to painting, ensure plastic port plugs are tightly in place.

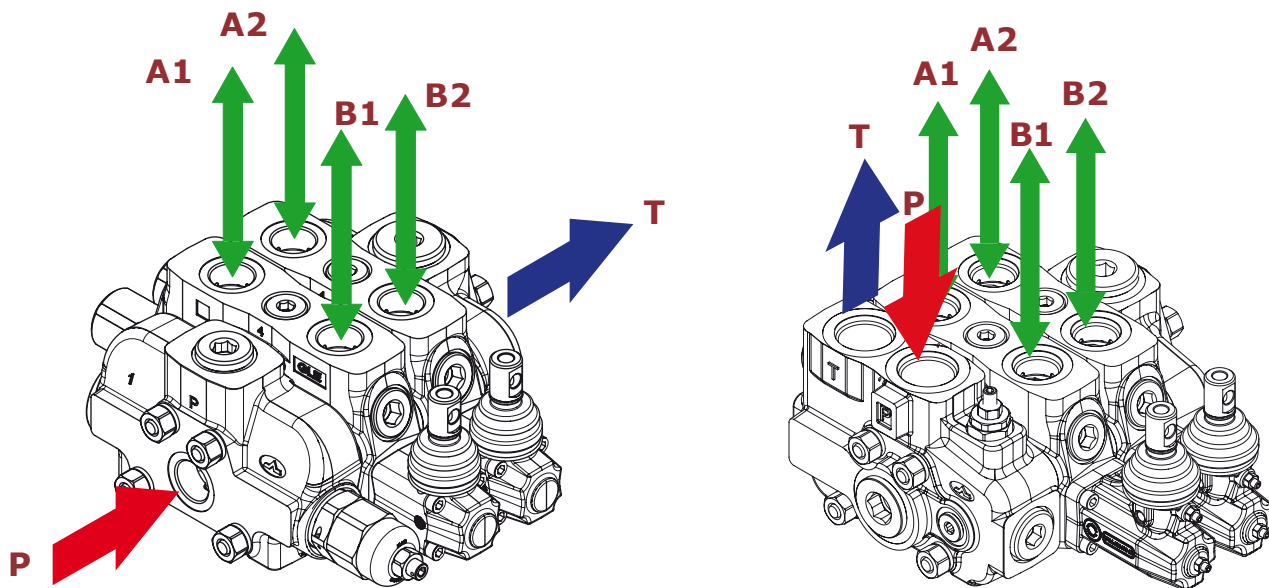

Fitting tightening torque - Nm ( <i>lbf</i> )				
THREAD TYPE	port P	ports A, B	port T	Hydraulic pilot
BSP	G 3/4	G 3/4	G 1	G 1/4
With O-Ring seal	90 (66.4)	90 (66.4)	100 (73.7)	25 (18.4)
With copper washer	90 (66.4)	90 (66.4)	90 (66.4)	30 (22.1)
With steel and rubber washer	70 (51.6)	70 (51.6)	100 (73.7)	16 (11.8)
UN-UNF	1 5/16-12 (SAE 16)	1 1/16-12 (SAE 12)	1 5/16-12 (SAE 16)	9/16-18 (SAE 6)
With O-Ring seal	150 (110.6)	95 (70.1)	150 (110.6)	30 (22.1)

NOTE – These torque are recommended. Assembly tightening torque depends on many factors, including lubrication, coating and surface finish. The manufacturer shall be consulted.

### Coils

#### Types and ordering codes

Coil type	Voltage	Connectors					
		ISO4400	Deutsch DT	AMP JPT	Packard Weatherpack	Packard Metri-pack	Flying leads (without conn.)
BER	10 VDC	4SLE001000A	-	-	-	-	-
	12 VDC	4SLE001200A	4SLE001201 <sup>(5)</sup>	4SLE001203 <sup>(5)</sup>	4SLE001210 <sup>(2)</sup>	4SLE001214 <sup>(2)</sup>	4SLE001207
		4SLE001217A <sup>(3)</sup>	4SLE001209 <sup>(3-5)</sup> 4SLE001202 <sup>(6)</sup> 4SLE001216 <sup>(3-6)</sup> 4SLE001206 <sup>(2)</sup>	4SLE001211 <sup>(3-5)</sup>	-	-	-
	24 VDC	4SLE002400A	4SLE002401 <sup>(5)</sup>	4SLE002403 <sup>(5)</sup>	-	-	4SLE002404
		4SLE002408A <sup>(3)</sup> 4SLE302400A <sup>(4)</sup>	4SLE002407 <sup>(3-5)</sup> 4SLE002402 <sup>(6)</sup>	-	-	-	-
	48 VDC	4SLE004800A 4SLE304800A <sup>(1)</sup>	-	-	-	-	-
110VDC	4SLE011000A 4SLE311000A <sup>(1)</sup>	-	-	-	-	-	
220 VDC	4SLE022000A 4SLE322000A <sup>(1)</sup>	-	-	-	-	-	
BE	12 VDC	4SL1000120	4SL1000123 <sup>(6)</sup> 4SL1000140 <sup>(3-6)</sup> 4SL1000124 <sup>(2)</sup>	-	-	-	4SL1000122
	24 VDC	4SL1000240 4SL1030240 <sup>(1)</sup>	4SL1002401 <sup>(6)</sup>	-	-	-	-
	110 VDC	4SL1011100 4SL1031100 <sup>(1)</sup>	-	-	-	-	-
	220 VDC	4SL1022200 4SL1032200 <sup>(1)</sup>	-	-	-	-	-
BT	10 VDC	4SL3000100	-	-	-	-	-
	12 VDC	4SL3000120	4SL3000130 <sup>(6)</sup>	4SL3000122 <sup>(5)</sup>	4SL3000124 <sup>(2)</sup>	4SL3000127 <sup>(2)</sup>	4SL300012C
		4SL3000126 <sup>(4)</sup>	4SL3000134 <sup>(3-6)</sup> 4SL3000128 <sup>(2)</sup>	4SL30001200 <sup>(3-5)</sup>	-	-	-
	24 VDC	4SL3000240 4SL3030240 <sup>(1)</sup>	4SL3000249 <sup>(6)</sup> 4SL300024C <sup>(3-6)</sup>	4SL3000248 <sup>(5)</sup>	-	-	4SL3000246
	26 VDC	4SL3000260	-	-	-	-	-
	48 VDC	4SL3000480 4SL3030480 <sup>(1)</sup>	-	-	-	-	-
110 VDC	4SL3001100 4SL3031100 <sup>(1)</sup>	-	-	-	-	-	
220 VDC	4SL3002200 4SL3032200 <sup>(1)</sup>	-	-	-	-	-	
BPV	12 VDC	4SLA001200	-	-	-	-	-
	24 VDC	4SLA002400	-	-	-	-	-
<b>Mating connectors</b> (For connector with rectifier see following table)		4CN1009995	5CON140031	5CON003	5CON001	5CON017	-

Notes: <sup>(1)</sup> supply with AC and use only with rectifier connector - <sup>(2)</sup> with flying leads - <sup>(3)</sup> with bidirectional diode - <sup>(5)</sup> with unidirectional diode  
<sup>(4)</sup> integrated perpendicular type - <sup>(6)</sup> integrated parallel type

Voltage	ISO 4400 mating connector with rectifier			
	BER type coil	BT type coil	BPV type coil	BE type coil
24 VDC	4CN1010240	4CN3010240	-	4CN1010240
48 VDC	4CN1010480	4CN3010480	-	4CN1010480
110 VDC	4CN1011100	4CN3011100	-	4CN1011100
220 VDC	4CN1012200	4CN3012200	-	4CN1012200







Fixing brackets

They are available for SDS180/DLS180 directional valves and they are zinc plated steel, complete with mounting screws.

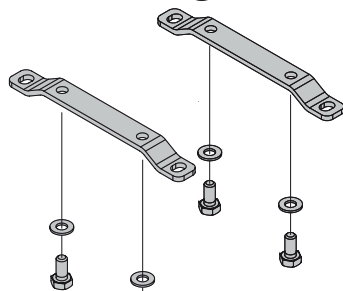
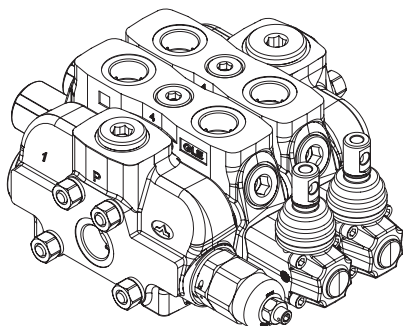

M10 x 4  
Wrench 16  
24 Nm - 17.7 lbft

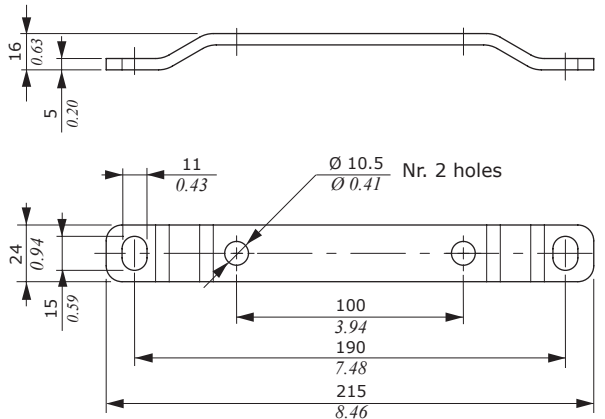

Painting

SDS180 valve can be supplied with one coat of black paint (**CVN** configuration).

Description example: SDS180/2/AC(YG3-120)/18L/18L/RC-SAE<**CVN**>

NOTE - For different colour consult Sales Department.

**Notes**

---





Innovation · Continuity · Integration  
It is Power

 **walvoil**  
FLUID POWER EMOTION

 **walvoil**

 **hydro control**

 **Galtech**  
SOLUTIONS

D1WWEB01A

10<sup>th</sup> edition December 2018

Walvoil S.P.A. • 42124 Reggio Emilia • Italy • Via Adige, 13/D • Tel. +39.0522.932411 • Fax +39.0522.300984  
[www.walvoil.com](http://www.walvoil.com)

