



MONOBLOCK  
DIRECTIONAL CONTROL VALVE

S  
L  
M 143



## Features

Simple, compact and heavy duty designed 2 sections monoblock valve are used in Front Loader application with open center and closed center hydraulic systems.

H Parallel circuit.

H Fitted with a main pressure relief valve and a load check valve on every working section.

H Available with manual and remote with flexible cables spool control kits.

H Diameter 18 mm - 0.71 in interchangeable spools.

H A wide variety of service port valves.

H Optional power beyond port.

### Additional information

This catalog shows the product in the most standard configurations.

Please contact Customer Service Dpt. for more detailed information or special request.

### WARNING!

All specifications of this catalog refer to the standard product at this date.

Walvoil, oriented to a continuous improvement, reserves the right to discontinue, modify or revise the specifications, without notice.

WALVOIL IS NOT RESPONSIBLE FOR ANY DAMAGE CAUSED BY AN  
INCORRECT USE OF THE PRODUCT.

6<sup>th</sup> edition February 2001:

**This edition supercedes all prior documents.**

**Contents**

Working conditions .....	4
Dimensional data .....	5
Hydraulic circuit .....	6
Performance data .....	7
Ordering codes .....	8
Inlet relief options .....	10
Spool .....	11
"A" side spool positioners .....	12
"B" side options .....	13
Port relief options .....	14
Installation and maintenance .....	17

# SDM143

## Working conditions

This catalog shows technical specifications and diagrams measured with mineral oil of 46 mm<sup>2</sup>/s - 46 cSt viscosity at 40°C - 104°F temperature.

Nominal flow rating		80 l/min	21 US gpm
Operating pressure (maximum)		250 bar	3600 psi
Max. back pressure	<i>on outlet port T</i>	10 bar	145 psi
Internal leakage A(B)→T	<i>Δp=100 bar - 1450 psi fluid and valve at 40°C - 104°F</i>	3 cm <sup>3</sup> /min	0.18in <sup>3</sup> /min
Fluid		Mineral oil	
Fluid temperature range	<i>with NBR (BUNA-N) seals</i>	from -20° to 80°C	<i>from -4° to 176°F</i>
	<i>with FPM (VITON) seals</i>	from -20° to 100°C	<i>from -4° to 212°F</i>
Viscosity	<i>operating range</i>	from 15 to 75 mm <sup>2</sup> /s	<i>from 15 to 75 cSt</i>
	<i>min.</i>	12 mm <sup>2</sup> /s	12 cSt
	<i>max.</i>	400 mm <sup>2</sup> /s	400 cSt
Max level of contamination		19/16 - ISO 4406	NAS 1638 - class10
Ambient temperature range		from -40° to 60°C	<i>from -40° to 140°F</i>

NOTE - For different conditions please contact Customer Service.

## Dimensional data

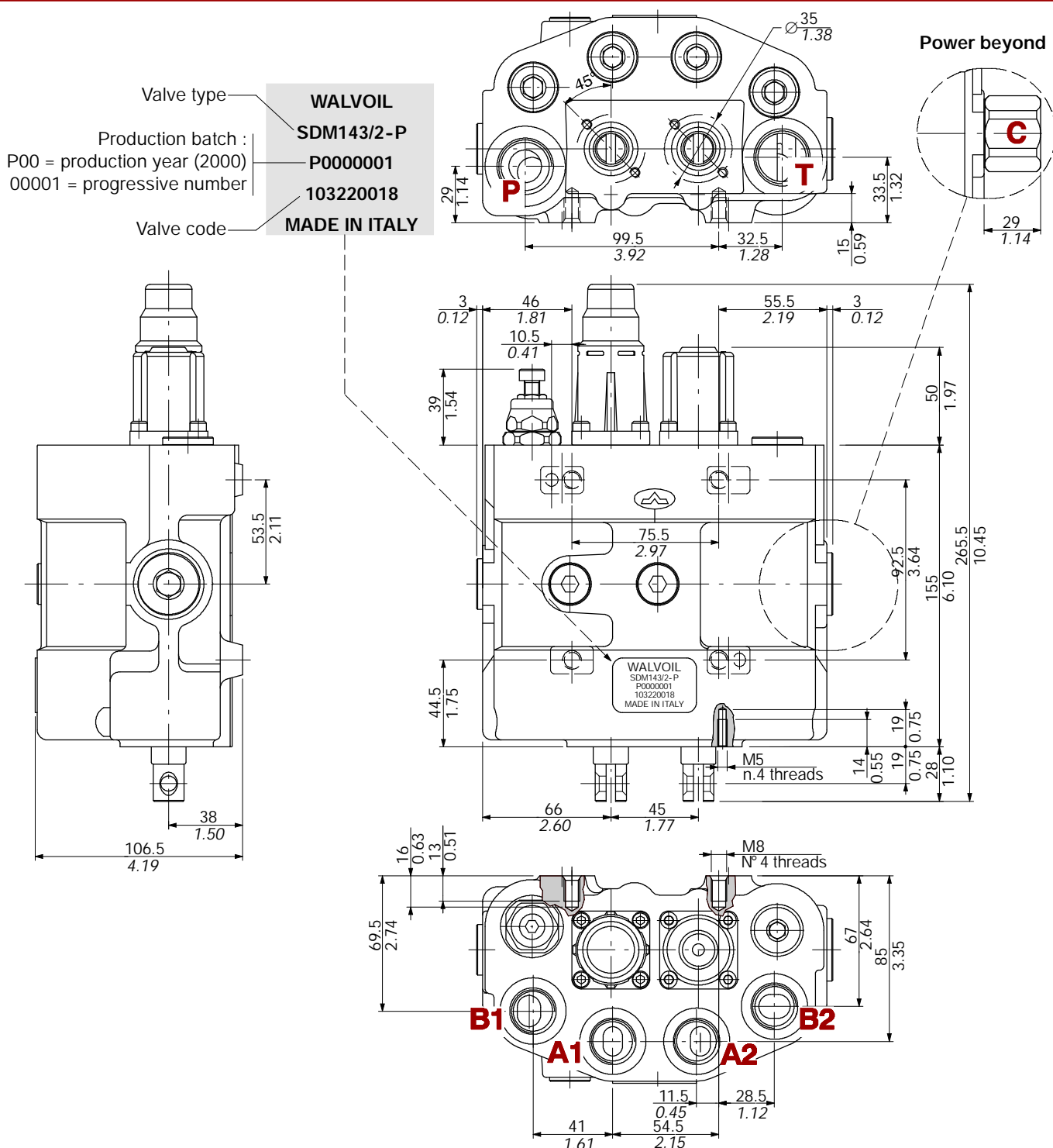

### Standard threads

PORTS	BSP (ISO 228/1)	UN-UNF (ISO 11926-1)	METRIC (ISO 262)
Inlet <b>P</b> and power beyond <b>C</b>	G 3/4	1 1/16-12 UN-2B (SAE 12)	M27x2
<b>A</b> and <b>B</b> ports	G 1/2	7/8-14 UNF-2B (SAE 10)	M22x1,5
Outlet <b>T</b>	G 3/4	1 1/16-12 UN-2B (SAE 12)	M27x2

# SDM143

## Hydraulic circuit

Standard execution is with open center circuit (**AET** configuration)

Allen wrench 8  
24 Nm / 17.7 lbf

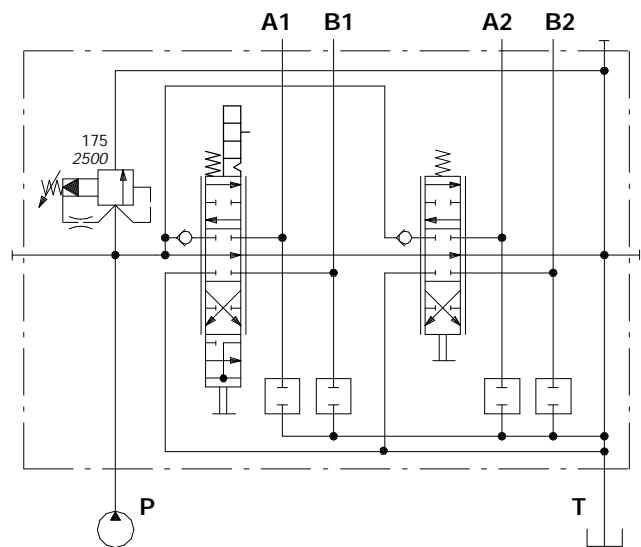
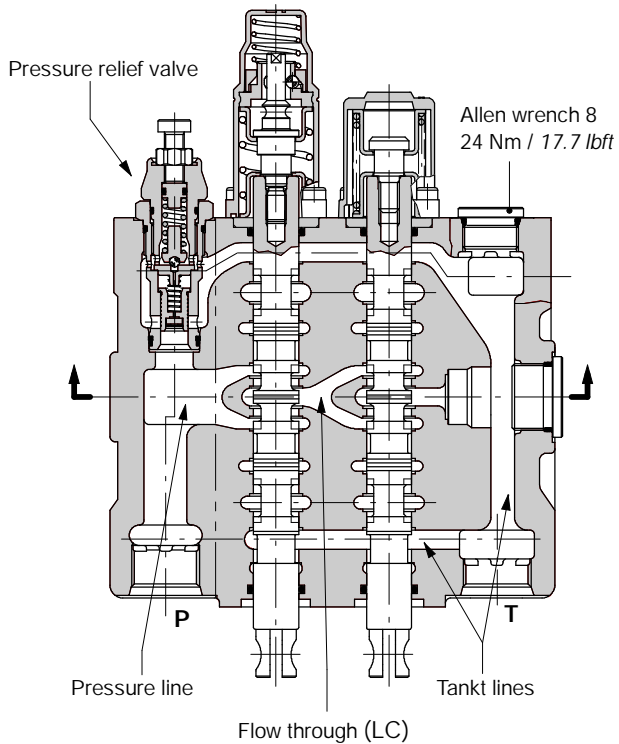
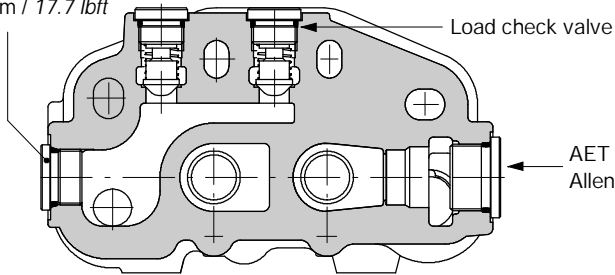

Ex.: SDM143/2-P(XG-175)/113SL/18SL/AET-<CVN>

## AE: with power beyond

SAE12 power beyond female sleeve  
Wrench 36 - 42 Nm / 31 lbf

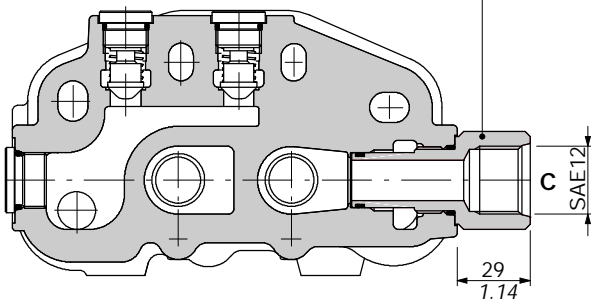

Ex.: SDM143/2-P(XG-175)/113SL/113SL/AE-<CVN>

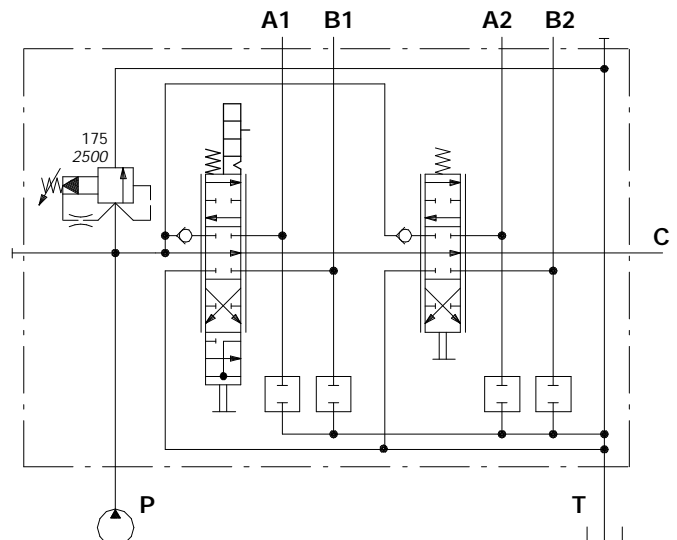

## Performance data (pressure drop vs. flow)

## Open center

From inlet to outlet

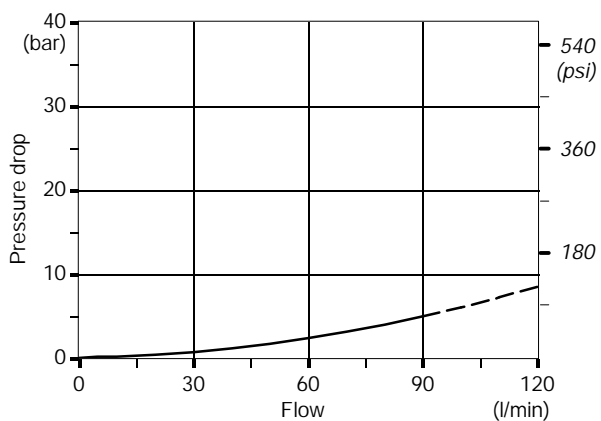
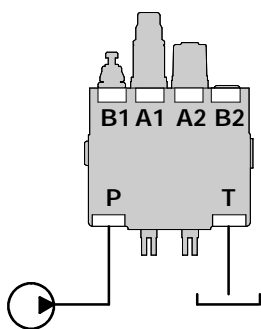

## Inlet to work port

From inlet to A (spool in position 1) or B (spool in position 2).

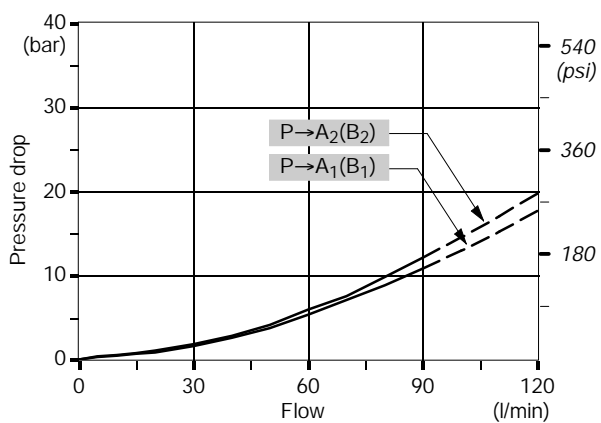
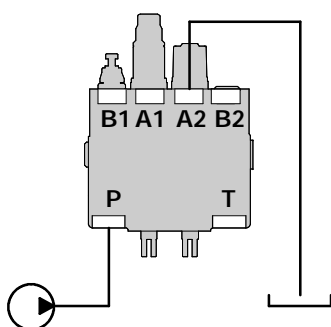

## Work port to outlet

From A port (spool in position 2) or B port (spool in position 1) to outlet.

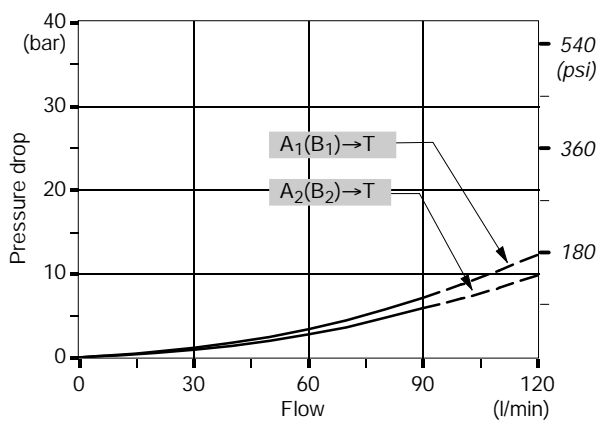
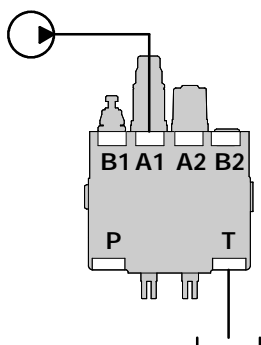

# SDM143

## Ordering codes

### Description example:

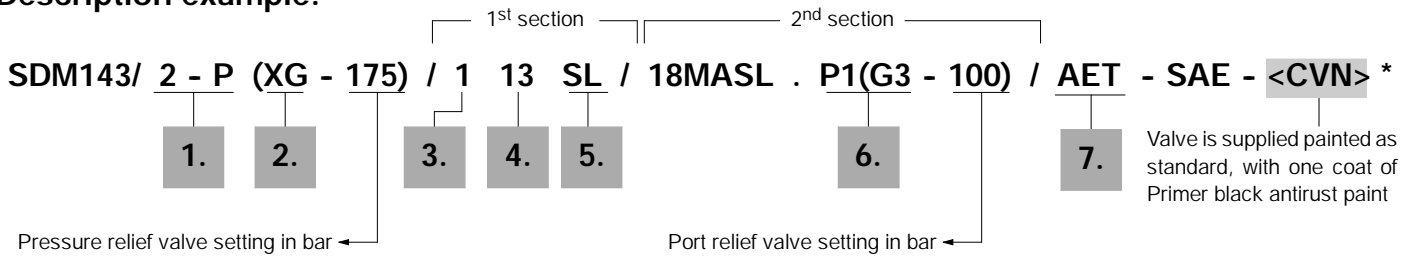

### 1. Body kit \*

TYPE	CODE	DESCRIPTION
2-P	5KC1877000	2 sections

Include body, seals, rings and load check valves.

### 2. Inlet relief options page 10

TYPE	CODE	DESCRIPTION
<u>VMP140 pilot operated pressure relief valve type X (standard)</u>		
(XG-175)	X134211175	Range 25 to 250 bar / 360 to 3600 psi standard setting 175 bar / 2500 psi
<u>VMD140 direct pressure relief valve type Y</u>		
(YG3-175)	X134121175	Range 125 to 250 bar / 1800 to 3600 psi standard setting 175 bar / 2500 psi
Standard setting is referred to 10 l/min - 2.6 US gpm flow.		
SV	XTAP530590	Relief valve blanking plug

### 3. Spool page 11

TYPE	CODE	CIRCUIT DESCRIPTION
1	3CU1310120	Double acting, 3 positions, A and B closed in neutral position with positioner kit 8MA 4 positions, A and B to tank in 4th positions (float) with positioner kit 13

### 4. "A" side spool positioner page 12

TYPE	CODE	DESCRIPTION
8MA	5V08108240	With spring return in neutral position
13	5V13108040	With detent in position 3 and spring return in neutral position

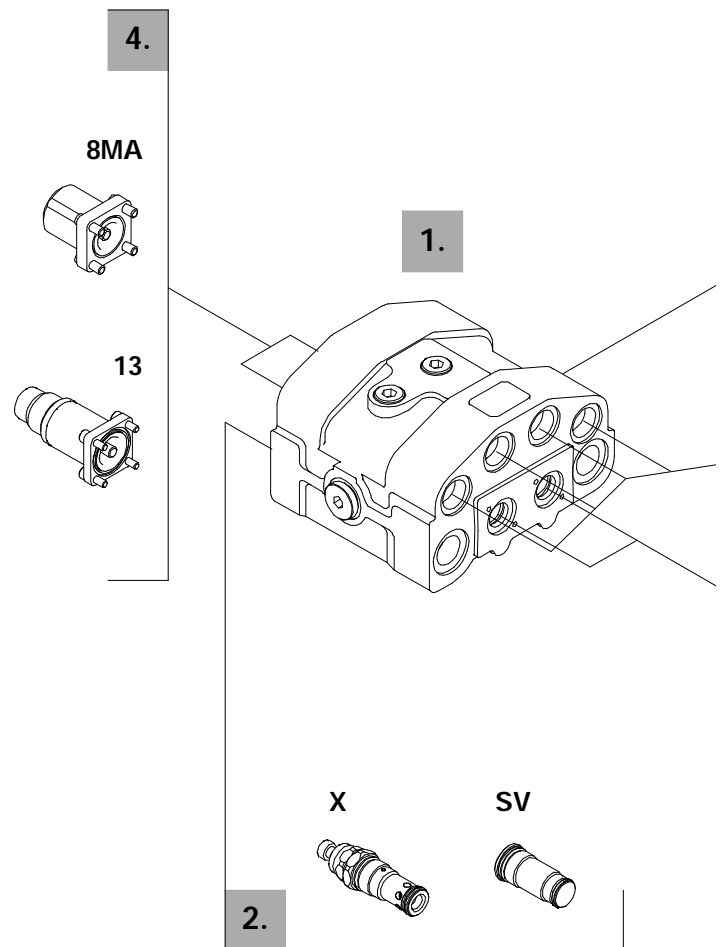



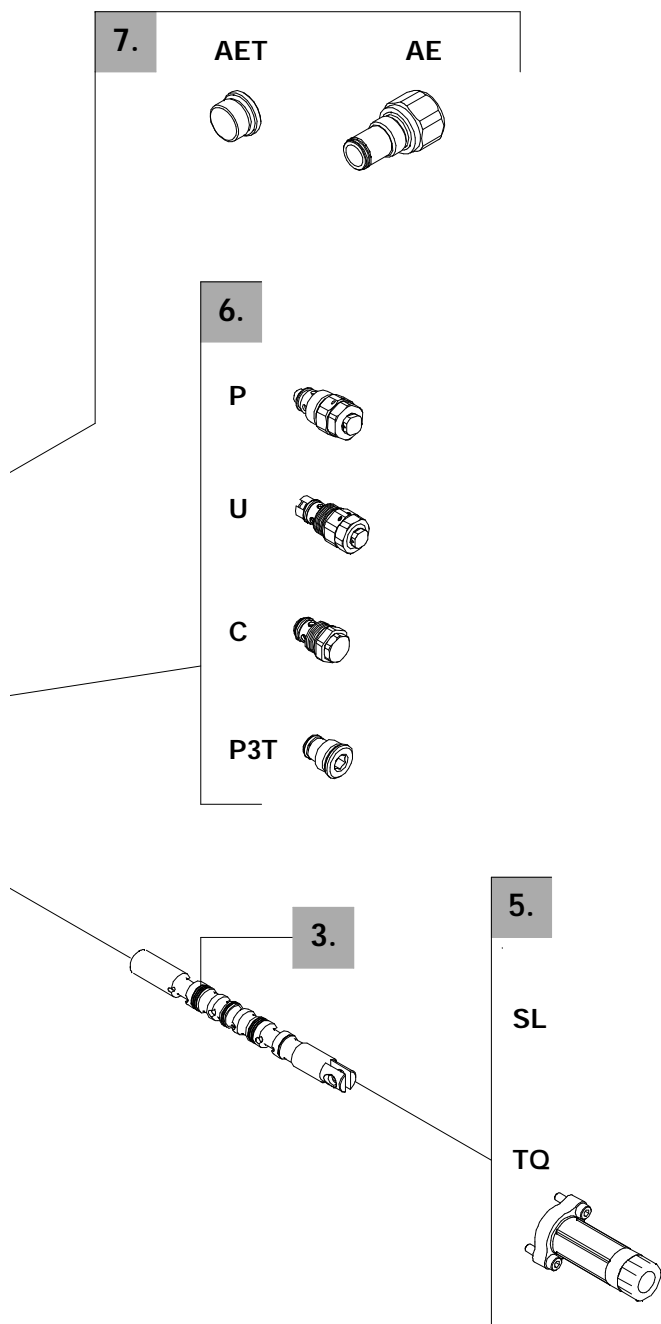

### 5. "B" side options page 13

TYPE	CODE	DESCRIPTION
SL	-	Without control
TQ	5TEL108220	Cable control

### 6. Port relief options page 14

TYPE	CODE	DESCRIPTION
<u>Anti-shock valve</u>		
P(G3-100)	3XCAR208113	Range 100 to 250 bar / from 1450 to 3600 psi standard setting 100 bar / 1450 psi
P(G4-200)	3XCAR208114	Range 200 to 315 bar / from 2900 to 4600 psi standard setting 200 bar / 2900 psi
<u>Anti-shock and anti-cavitation valve</u>		
U(G2-63)	XCAR308112	Range 63 to 125 bar / from 900 to 1800 psi standard setting 63 bar / 900 psi
U(G3-100)	XCAR308115	Range 100 to 250 bar / from 1450 to 3600 psi standard setting 100 bar / 1450 psi
U(G4-200)	XCAR308114	Range 200 to 315 bar / from 2900 to 4600 psi standard setting 200 bar / 2900 psi

Standard setting is referred to 10 l/min - 2.6 US gpm flow.

C	XCAR408110	Anti-cavitation
P3T	3XTAP524290	A and B ports valve blanking plugs

### 7. Hydraulic circuit page 6

TYPE	CODE	DESCRIPTION
AET	3XTAP732201	Open center
AE	XGIU532661	SAE 12 female carry-over sleeve*

NOTE (\*) - Items are referred to UN-UNF thread.

# SDM143

## Inlet relief options

### Pilot operated pressure relief valve

#### VMP140 (X G - 175)

Pressure setting in bar (standard 175 - 2500 psi)  
Adjustment type (G, Z)

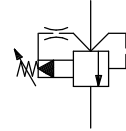

### Adjustment type

**G:** with screw

**Z:** with nylon tamper proof cap

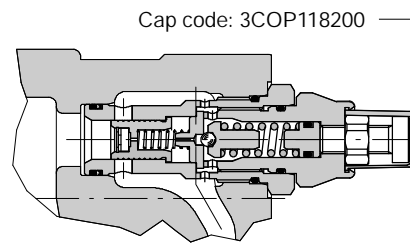
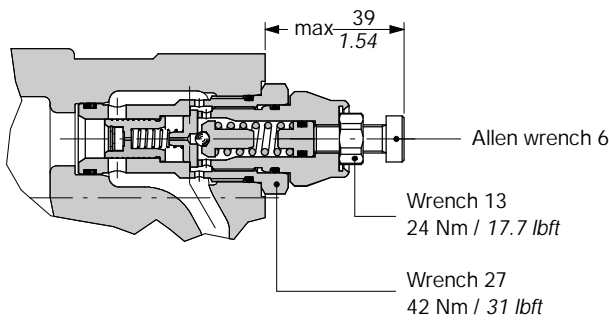

### Performance data

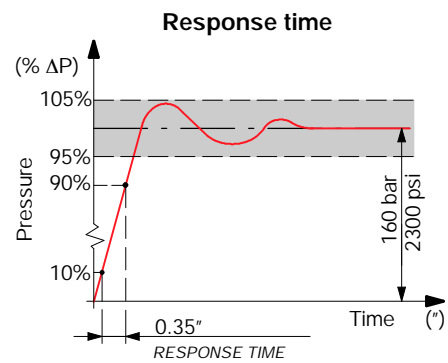
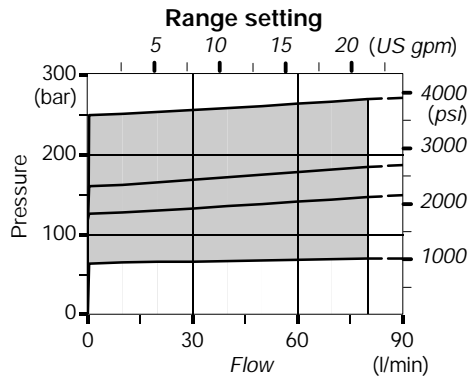

### SV: relief valve blanking plug

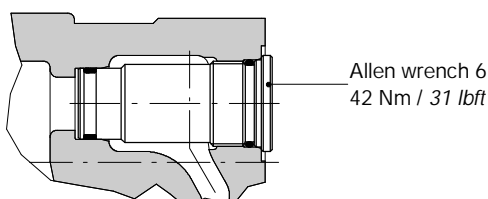

### Type 1

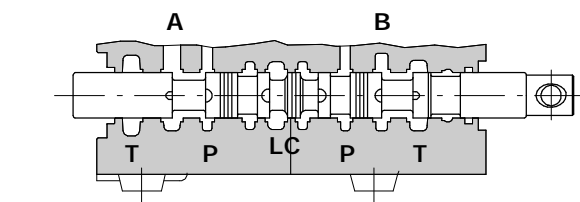

P → A B → T

stroke = + 7 mm  
+ 0.28 in

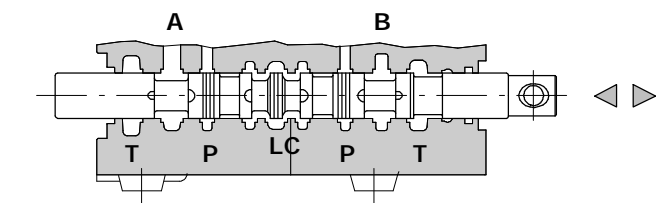
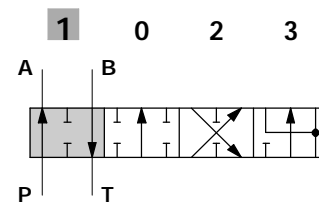

P-A-B-T closed, with flow through line (LC) open

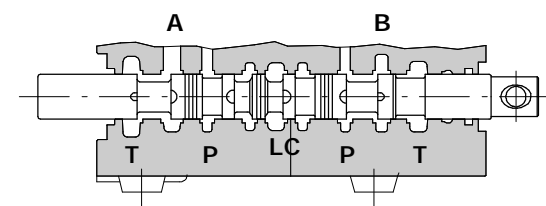
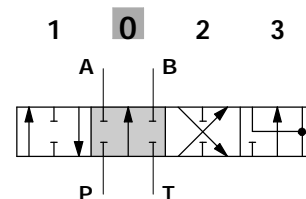

P → B A → T

A stroke = - 7 mm  
- 0.28 in

**A** stroke = - 6.7 mm  
- 0.26 in

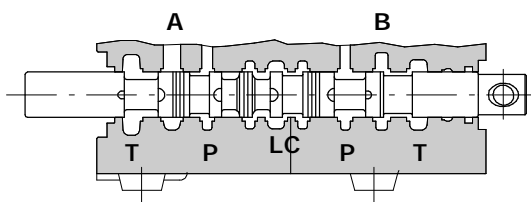
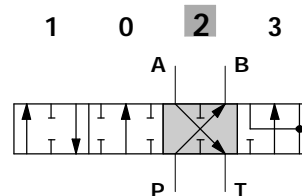

A(B) → T (floating circuit)

**AA** stroke = - 12 mm  
- 0.47 in

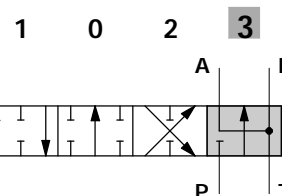

NOTE - **A** Only for positioner kit type 13

### Performance data

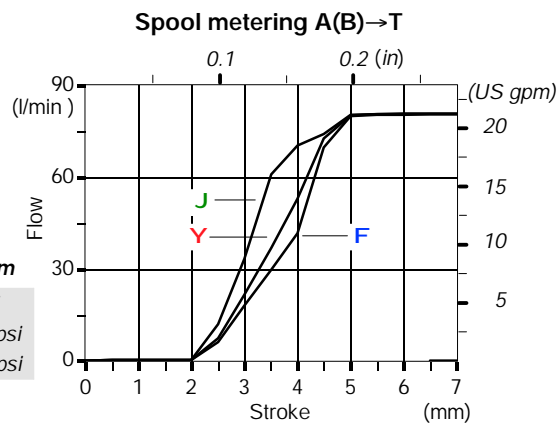
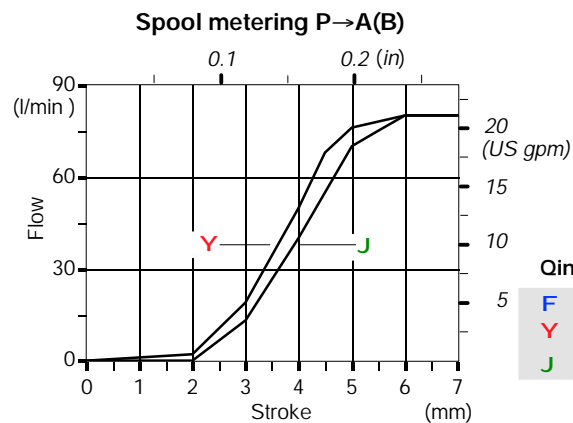

# SDM143

## "A" side spool positioner

### With spring return

#### 8MA kit

Supplied with standard spring type A (see force-stroke diagram).

Available with heavier spring type B (**8** code: 5V08108010) or type C (**8MC** code: 5V08208000).

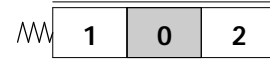

Allen wrench 4  
6.6 Nm / 4.9 lbf

Allen wrench 6  
24 Nm / 17.7 lbf

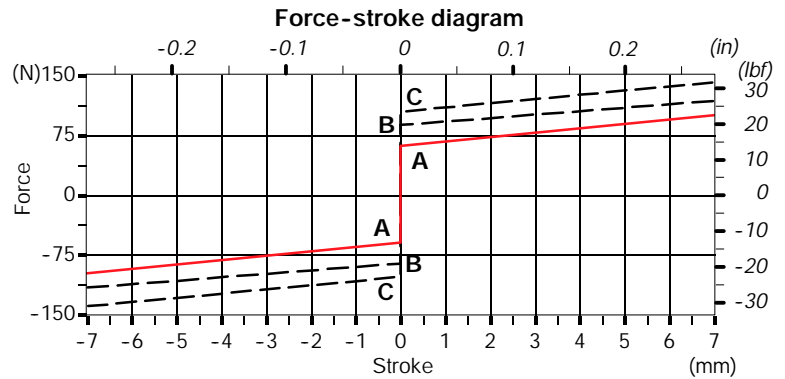
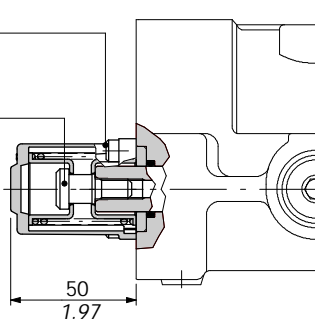

### With detent on 4<sup>th</sup> position for floating circuit

#### 13 kit

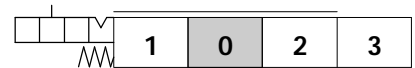

Allen wrench 4  
6.6 Nm / 4.9 lbf

Wrench 6  
24 Nm / 17.7 lbf

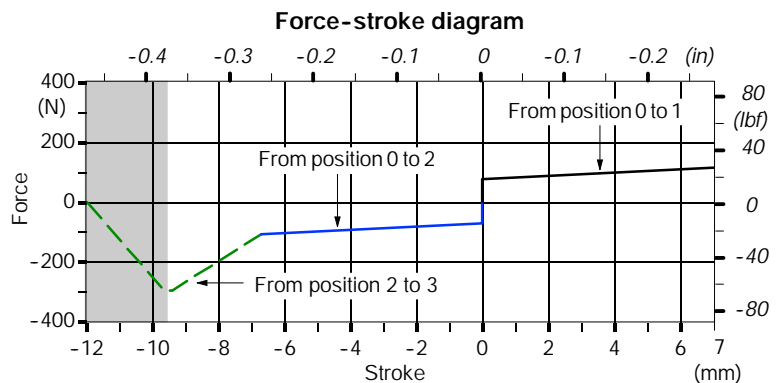
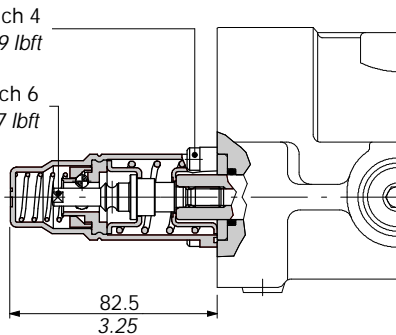

Locking-unlocking area  
 Locking force: 300 N / 67.4 lbf ±10%  
 Unlocking force: 270 N / 60.7 lbf ±10%

SL: without control

1	0	2
---	---	---

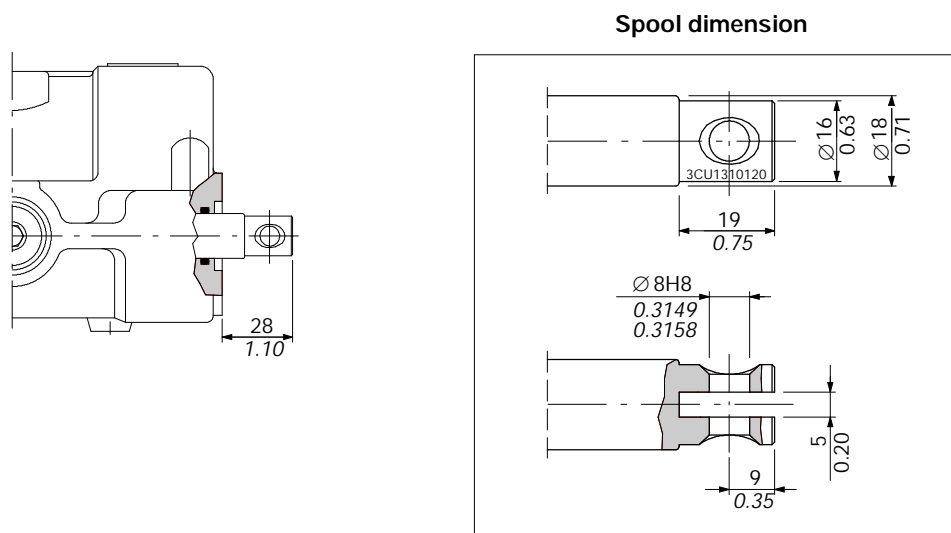

TQ cable remote control

Waterproof cap for remote control with flexible cable.

1	0	2
---	---	---

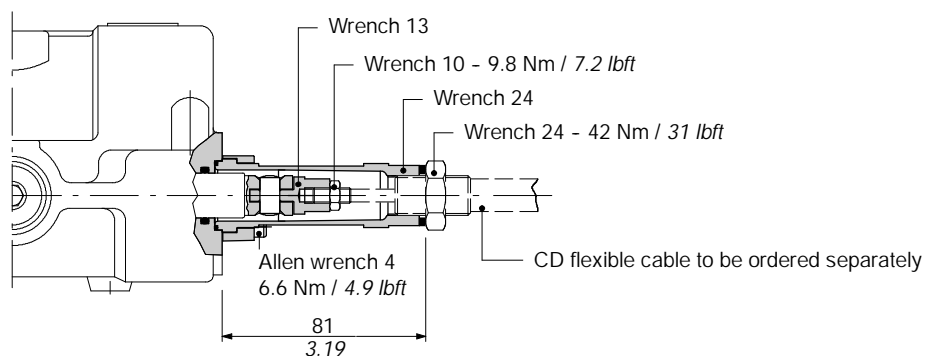

NOTE - For more information concerning remote cable control require appropriate documentation.

# SDM143

## Port relief options

### Anti-shock valve

**P 1 ( G 3 - 100 )**

- Pressure setting in bar.
- Spring type **(3, 4)**.
- Adjustment type **(G, H)**.
- 1** mounted on A port.
- 2** mounted on B port.
- 3** mounted on A and B ports.

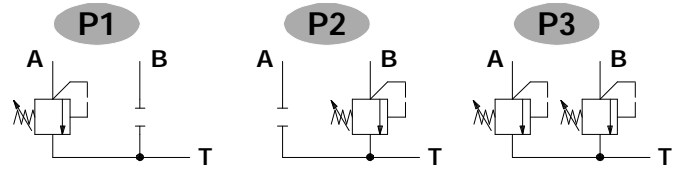

### Adjustment type

**G: with screw**

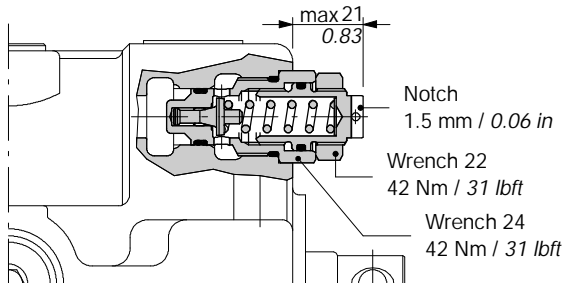

**H: valve set and locked**

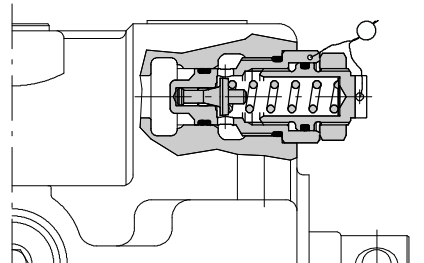

### Performance data

**Spring # 3 (blue band)**

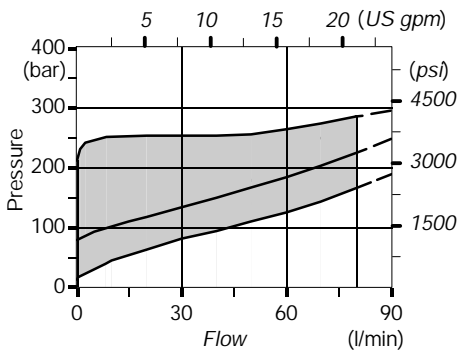

**Spring # 4 (red band)**

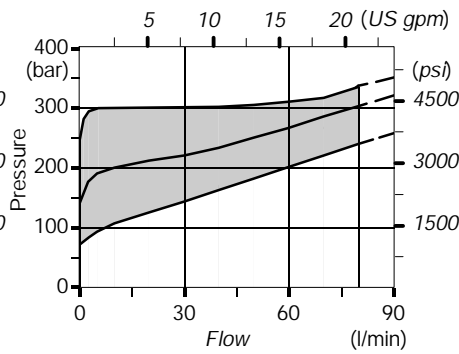

**Response time**

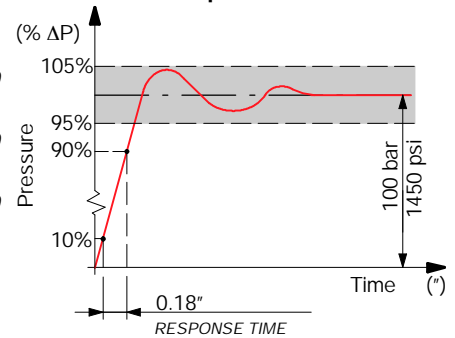

### Anti-shock and anti-cavitation valve

**U 1 ( G 3 - 100 )**

- Pressure setting in bar.
- Spring type (2, 3, 4).
- Adjustment type (G, H).
- 1 mounted on A port.
- 2 mounted on B port.
- 3 mounted on A and B ports.

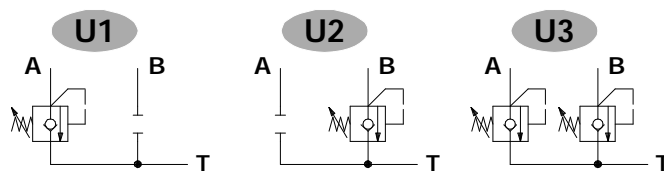

### Adjustment type

**G: with screw**

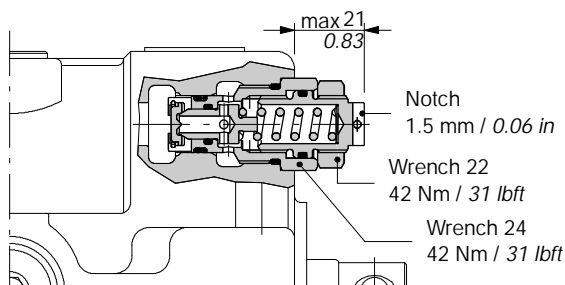

**H: valve set and locked**

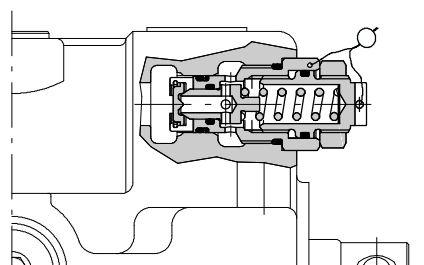

### Performance data

**Spring # 2 (green band)**

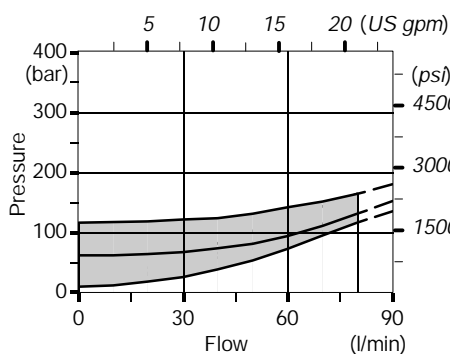

**Spring # 3 (blue band)**

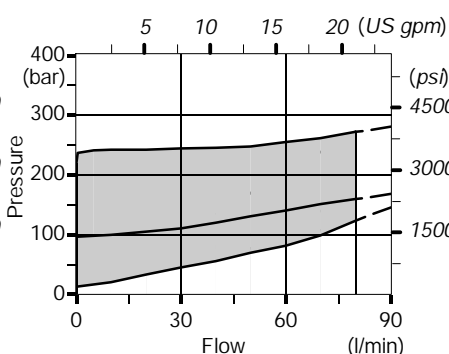

**Spring # 4 (red band)**

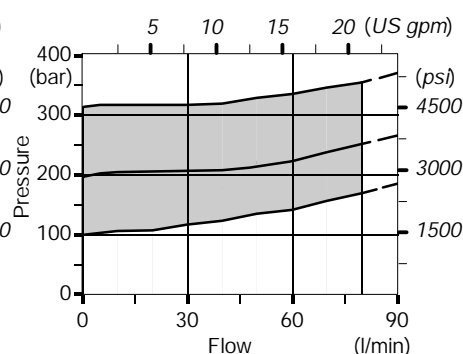

**Response time**

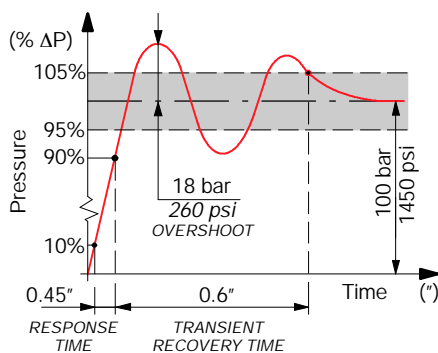

**Pressure drop**

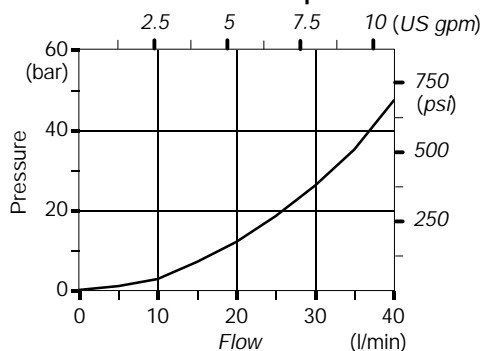

# SDM143

## Port relief options

### Anti-cavitation valve

C 1

- 1 mounted on A port.
- 2 mounted on B port.
- 3 mounted on A and B ports.

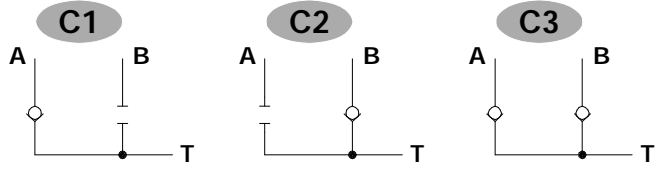

### Performance data

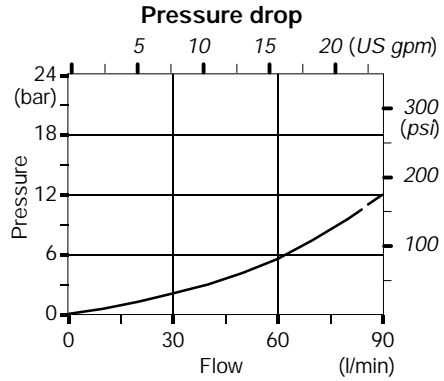
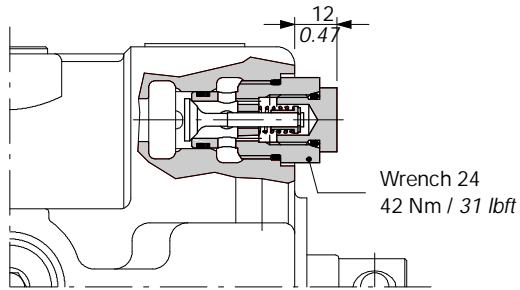

### P3T: port relief valve blanking plug

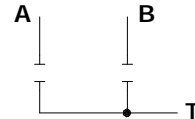
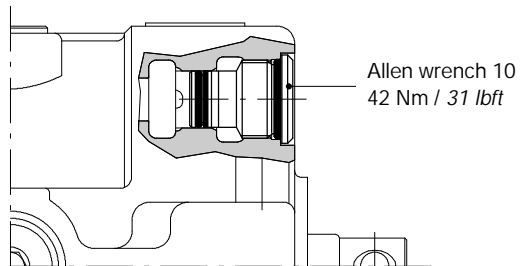



## Installation and maintenance

The SDM143 valve is assembled and tested as per the technical specification of this catalog.

Before the final installation on your equipment, follow the below recommendations:

- the valve can be assembled in any position, in order to prevent body deformation and spool sticking mount the product on a flat surface;
- in order to prevent the possibility of water entering the spool control kit, do not use high pressure wash down directly on the valve;
- prior to painting, ensure plastic port plugs are tightly in place.

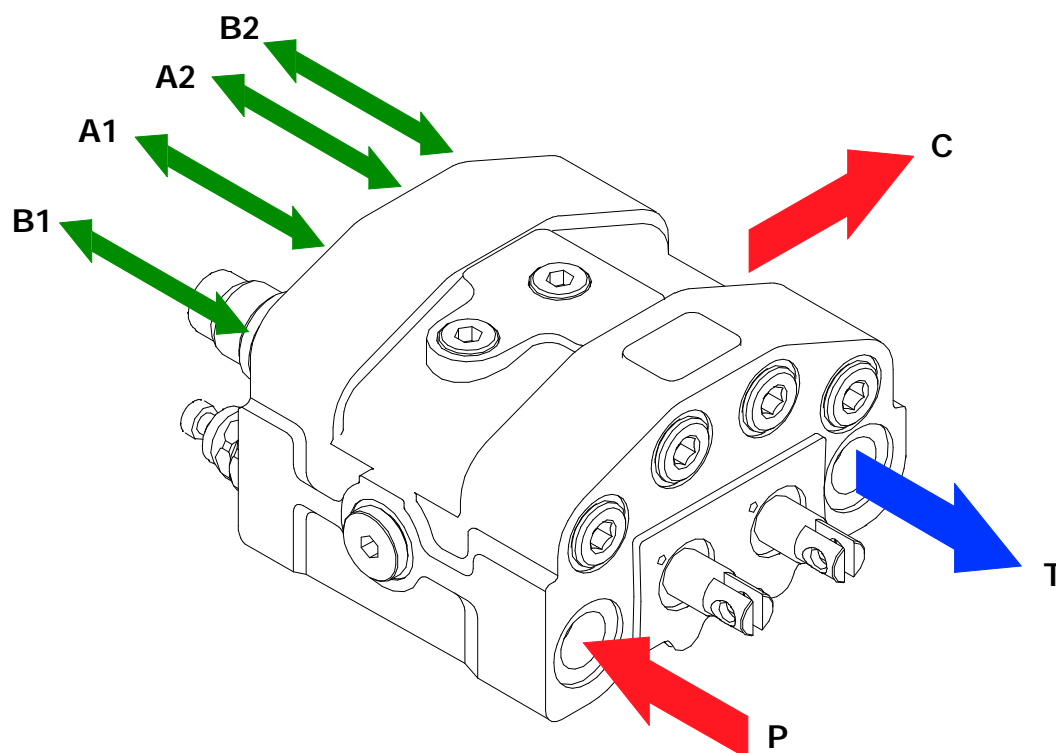

Power beyond configuration

### Fitting tightening torque - Nm / lbft

THREAD TYPE	P and C ports	A and B ports	T port
BSP (ISO 228/1)	G 3/4	G 1/2	G 3/4
With O-Ring seal	70 / 51.6	50 / 36.9	70 / 51.6
With copper washer	70 / 51.6	60 / 44.3	70 / 51.6
With steel and rubber washer	70 / 51.6	60 / 44.3	70 / 51.6
UN-UNF (ISO 11926-1)	1 1/16-12 UN-2B (SAE 12)	7/8-14 UNF-2B (SAE 10)	1 1/16-12 UN-2B (SAE 12)
With O-Ring seal	95 / 70.1	60 / 44.2	95 / 70.1
METRIC (ISO 262)	M27 x 2	M22 x 1.5	M27 x 2
With O-Ring seal	90 / 66.4	50 / 36.9	90 / 66.4
With copper washer	60 / 44.3	40 / 29.5	60 / 44.3
With steel and rubber washer	70 / 51.6	60 / 44.3	70 / 51.6

NOTE - These torque are recommended. Assembly tightening torque depends on many factors, including lubrication, coating and surface finish. The manufacturer shall be consulted.

# SDM143

## Installation and maintenance

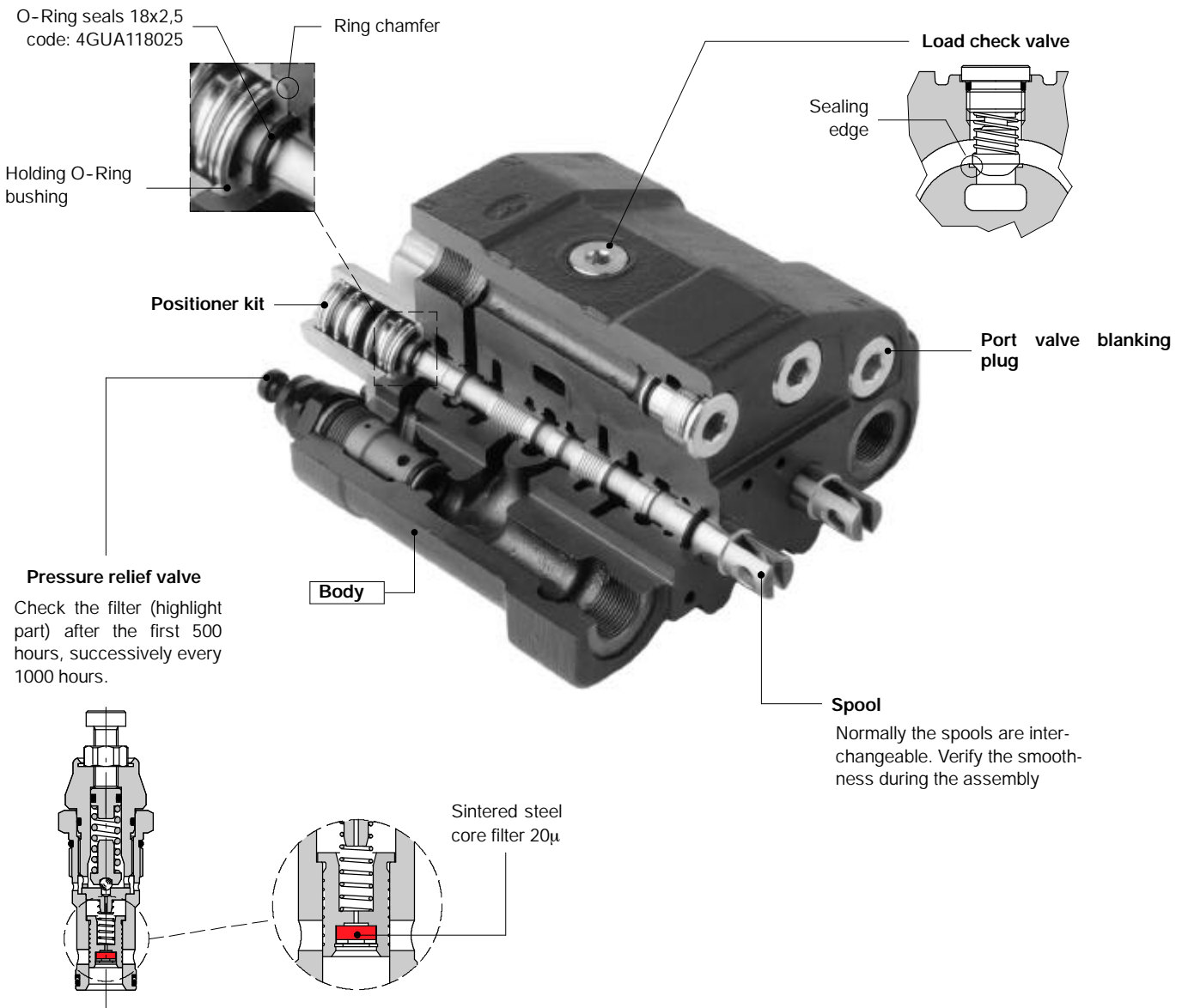

NOTE - All articulated parts inside cap are lubricated with synthetic base grease grade NLGI2.

Malfunction	Cause	Remedy
External leakage control kit or opposite side.	Worn spool seal due to mechanical actuation or high back pressure.	Locate the leakage and replace the seal. Check back pressure level.
Excessive internal leakage on A and B ports.	Increase clearance between spools and body due to high wear	Replace the directional control valve and check the oil contamination level.
Dropping load during transition while raising	High leakage on the load check valve.	Remove the load check valve and clean the seat.
Inability to build pressure on A and B ports.	Main pressure relief valve blocked open.	Remove and clean or replace the main relief valve.
	Port relief valve open.	Remove and clean or replace the port relief valve.
	Low pump pressure and flow.	Check the pump and circuit.





**WALVOIL S.P.A.**

42100 REGGIO EMILIA • ITALY • VIA ADIGE, 13/D  
TEL. +39.0522.932411 • FAX +39.0522.300984  
E-MAIL: INFO@WALVOIL.COM • HTTP: //WWW.WALVOIL.COM

**SALES DEPARTMENT**

TEL. +39.0522.932555 • FAX +39.0522.932455

DAT009A