



# **SDE030 - SDE060**

## **Bankable solenoid valves**

**TECHNICAL CATALOG**



## General informations

---

Simple, compact and heavy duty designed sectional valves from 1 to 10 sections.

### SDE030

- Aluminium alloy inlet sections, available in several configurations.
- Cast iron working sections
- Different types of spools.
- Optional check valves on workports.
- Available for parallel circuit.
- On/off solenoid controls.
- Emergency handlever available.

### SDE060

- Steel inlet sections, available in several configurations.
- Cast iron working sections
- Different types of spools.
- Different options to be flanged on the workports side
- Available for parallel and series circuits.
- On/off solenoid controls.
- Emergency handlever available.

### Additional information

This catalogue shows the product in the most standard configurations.  
Please contact Sales Dpt. for more detailed information or special request.

### WARNING!

All specifications of this catalogue refer to the standard product at this date.  
Walvoil, oriented to a continuous improvement, reserves the right to discontinue, modify or revise the specifications, without notice.

WALVOIL IS NOT RESPONSIBLE FOR ANY DAMAGE CAUSED BY AN  
INCORRECT USE OF THE PRODUCT.

6<sup>th</sup> edition December 2017

**Content**

Working conditions . . . . .	.4
Standard threads . . . . .	.4
Accessories	
Coils and connectors . . . . .	.56
Fixing brackets . . . . .	.59
Installation and maintenance . . . . .	.61

**SDE030**

Dimensions and hydraulic circuit . . . . .	.5
Complete sections ordering codes . . . . .	.6
- Inlet section	
Part ordering codes . . . . .	.8
Dimensions and hydraulic circuit . . . . .	.10
Options . . . . .	.13
- Working section	
Part ordering codes . . . . .	.16
Dimensions and hydraulic circuit . . . . .	.18
Spools . . . . .	.20
Control kits . . . . .	.21
Lower port relief valves . . . . .	.22
Side port relief valves . . . . .	.22
Check valves . . . . .	.23
Solenoid operated check valves . . . . .	.24
- Outlet section	
Dimensions and hydraulic circuit . . . . .	.25

**SDE060**

Dimensions . . . . .	.27
Hydraulic circuit . . . . .	.29
Complete sections ordering codes . . . . .	.30
- Inlet section	
Part ordering codes . . . . .	.32
Dimensions and hydraulic circuit . . . . .	.34
Options . . . . .	.39
- Working section	
Part ordering codes . . . . .	.46
Dimensions and hydraulic circuit . . . . .	.47
Lower port relief valves . . . . .	.48
Spools . . . . .	.49
Control kits . . . . .	.50
- Flangeable valve blocks	
Antishock valves . . . . .	.52
Check valves . . . . .	.53
Solenoid operated check valves . . . . .	.54
Counterbalance valves . . . . .	.56
- Outlet section	
Dimensions and hydraulic circuit . . . . .	.57

# SDE030-SDE060

## Working conditions

This catalogue shows technical specifications and diagrams measured with mineral oil of 46mm<sup>2</sup>/s - 46 cSt viscosity at 40°C - 104°F temperature.

		<b>SDE030</b>	<b>SDE060</b>
Nominal flow rating		30 l/min - 7.9 US gpm	30 l/min - 60 l/min 7.9 US gpm - 15.8 US gpm
Operating pressure (max.)	<i>parallel circuit</i>	250 bar - 3600 psi	315 bar - 4600 psi
	<i>series circuit</i>	-	210 bar - 3050 psi
Back pressure (max.)	<i>outlet port T</i>		210 bar - 3050 psi
	<i>outlet port T, with lever control</i>		30 bar - 435 psi
Internal leakage (max.) A(B)⇒T	$\Delta p = 100 \text{ bar} - 1450 \text{ psi}$ fluid and valve at 40°C - 104°F		14 cm <sup>3</sup> /min - 0.85 in <sup>3</sup> /min
Fluid		Mineral based oil	
Fluid temperature	<i>with NBR (BUNA-N) seals</i>	from -20°C to 80°C - from -4°F to 176°F	
	<i>with FPM (VITON) seals</i>	from -20°C to 100°C - from -4°F to 212°F	
Viscosity	<i>operating range</i>	from 15 to 75 mm <sup>2</sup> /s - from 15 to 75 cSt	
	<i>min.</i>	12 mm <sup>2</sup> /s - 12 cSt	
	<i>max.</i>	400 mm <sup>2</sup> /s - 400 cSt	
Max. contamination level		-/19/16 - ISO 4406 - NAS 1638 - class 10	
Ambient temperature for working conditions		from -20°C to 50°C - from -4°F to 122°F	

NOTE - For different conditions please contact Sales Dept.

## Standard threads

REFERENCE STANDARD			
		<b>BSP</b>	<b>UN-UNF</b>
THREAD ACCORDING TO		ISO 228/1	ISO 263
		BS 2779	ANSI B1.1 unified
CAVITY DIMENSION ACCORDING TO	ISO	1179	11926
	SAE		J11926
	DIN	3852-2 shape X or Y	

PORT THREADING	<b>SDE030</b>		<b>SDE060</b>			
			30 l/min (7.9 US gpm) sections		60 l/min (15.8 US gpm) sections	
	<b>BSP</b>	<b>UN-UNF</b>	<b>BSP</b>	<b>UN-UNF</b>	<b>BSP</b>	<b>UN-UNF</b>
Inlet <b>P</b> and outlet <b>T</b>	G 3/8	3/4-16 (SAE 8)	G 3/8	3/4-16 (SAE 8)	G 1/2	3/4-16 (SAE 8)
Working ports <b>A</b> and <b>B</b>	G 3/8	9/16-18 (SAE 6)	G 3/8	9/16-18 (SAE 6)	G 3/8	9/16-18 (SAE 6)
					G 1/2*	3/4-16 (SAE 8)*
Port <b>M</b>	G 1/4	9/16-18 (SAE 6)	G 1/4	7/16-20 (SAE 4) 9/16-18 (SAE 6)**	G 1/4	7/16-20 (SAE 4) 9/16-18 (SAE 6)**
Port <b>LS</b>	G 1/4	9/16-18 (SAE 6)	G 1/4	9/16-18 (SAE 6)	/	/

NOTE (\*) Optional thread - (\*\*) Only for type N inlet section

Dimensions

This drawing is referred to directional valve with 2 working sections and AN1 type inlet section.

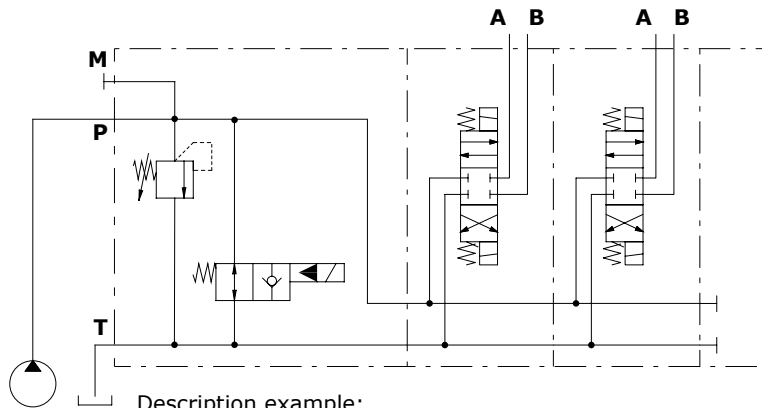
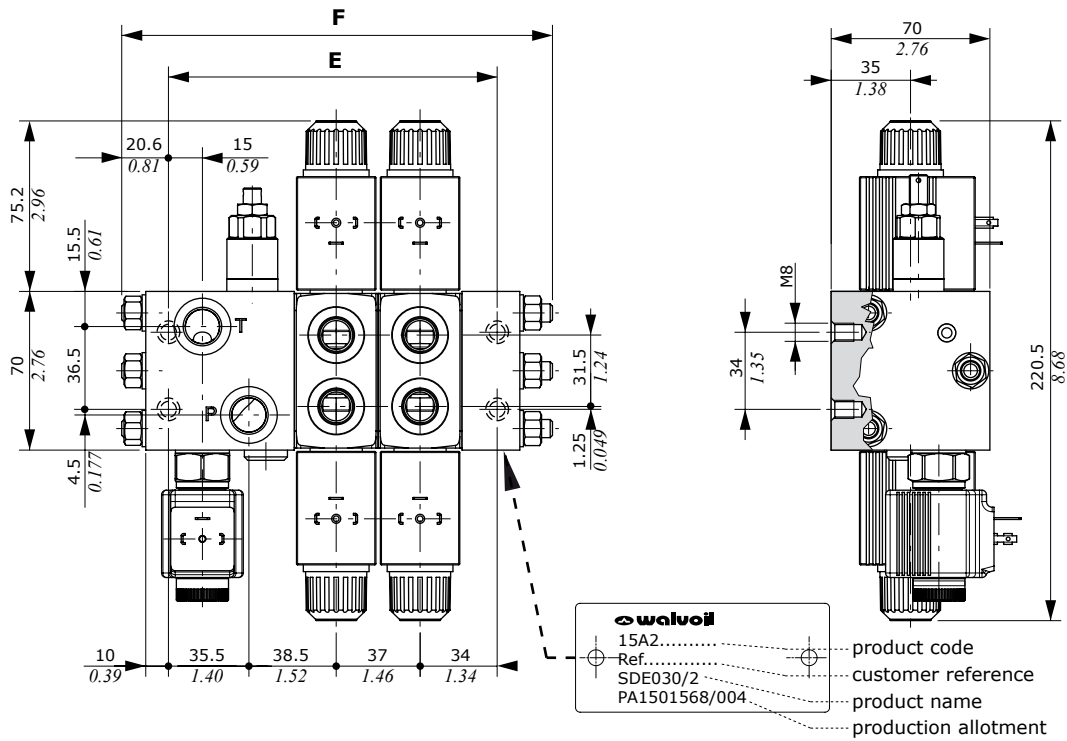

Description example:  
SDE030/2/AN1(JNG3-120)ELN/Q-18ES3B/Q-18ES3B/RF-12VDC

TYPE	AN type inlet section				AN1 type inlet section (see drawing)						AN2-AN6-AN7 type inlet sections			
	E		F		E		F		Weight		E		F	
	mm	in	mm	in	mm	in	mm	in	Kg	lb	mm	in	mm	in
SDE030/1	71	2.80	116	4.57	108	4.25	153	6.02	3.80	8.38	108	4.25	153	6.02
SDE030/2	108	4.25	153	6.02	145	5.71	190	7.48	5.99	13.21	145	5.71	190	7.48
SDE030/3	145	5.71	190	7.48	182	7.17	227	8.94	8.10	17.86	182	7.17	227	8.94
SDE030/4	182	7.17	227	8.94	279	10.98	264	10.39	10.22	22.53	279	8.62	264	10.39
SDE030/5	219	8.62	264	10.39	256	10.08	301	11.85	12.33	27.18	256	10.08	301	11.85
SDE030/6	256	10.08	301	11.85	293	11.54	338	13.31	14.44	31.83	293	11.54	338	13.31
SDE030/7	293	11.54	338	13.31	330	12.99	375	14.76	16.56	36.51	330	12.99	375	14.76
SDE030/8	330	12.99	375	14.76	367	14.45	412	16.22	18.67	41.16	367	14.45	412	16.22
SDE030/9	367	14.45	412	16.22	404	15.91	449	17.68	20.78	45.81	404	15.91	449	17.68
SDE030/10	404	15.91	449	17.68	441	17.36	486	19.13	22.89	50.46	441	17.36	486	19.13

## Complete section ordering codes

SDE030/4/ AN1(JNG3-120)ELN / Q-18ES3B / Q-18ES3B / QL-18ES3B /

Nr. of working sections

1

2

2

2

QBPE-18ES3B.BPEN(NC)3 / RF - ..... - 12VDC

2

3

4

5

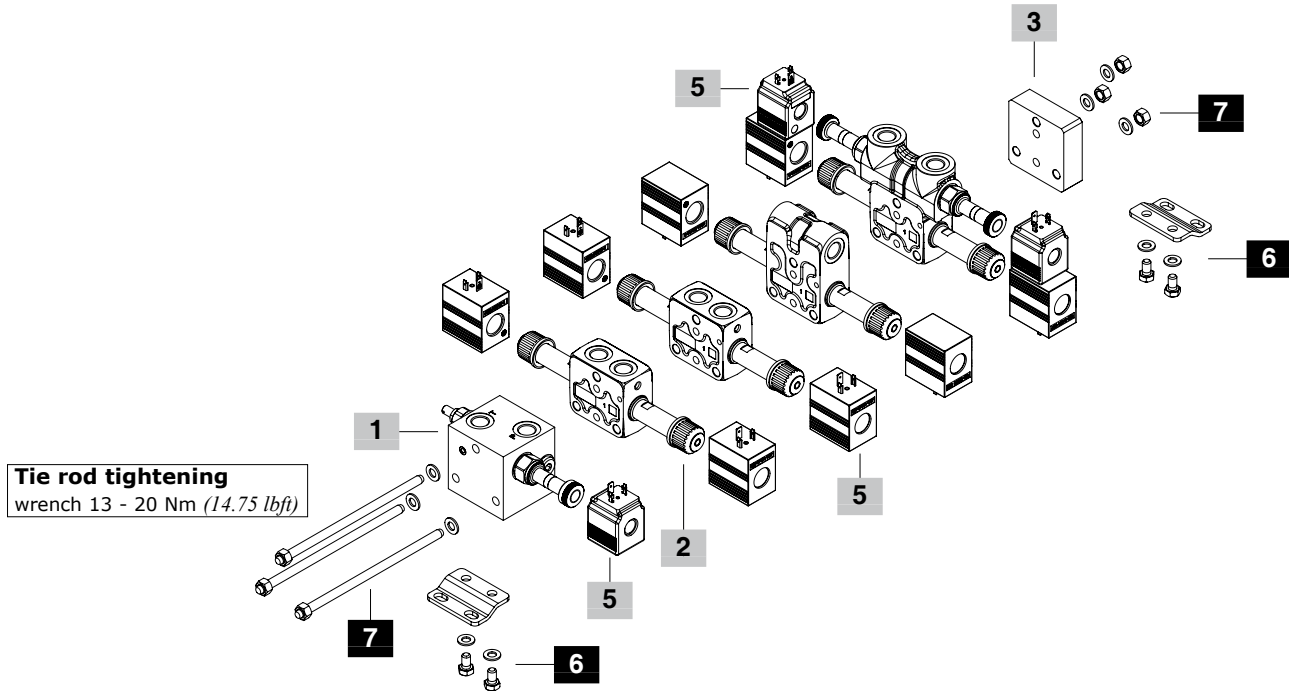

## Complete section ordering codes

**1 Complete inlet section \* page 10**

Section bodies are aluminium alloy made

TYPE: **AN-SAE** CODE: 6192G7000  
 DESCRIPTION: Without valves arrangement, P and T ports open  
 TYPE: **ANP-SAE** CODE: 6192G7001  
 DESCRIPTION: As AN, port P open and T plugged  
 TYPE: **ANT-SAE** CODE: 6192G7002  
 DESCRIPTION: As AN, port P plugged and T open  
 TYPE: **ANS-SAE** CODE: 6192G7003  
 DESCRIPTION: As AN, ports P and T plugged  
 TYPE: **AN1(JNG3-120)ELN-WC-SAE** CODE: Y61S3A7000  
 DESCRIPTION: Relief and unloader valves arrangement, P and T ports open  
 TYPE: **AN1P(JNG3-120)ELN-WC-SAE** CODE: Y61S3A7002  
 DESCRIPTION: As AN1, port P open and T plugged  
 TYPE: **AN2/PPXN1(JNG3-120)ELN-WC-SAE** CODE: Y61S3A7001  
 DESCRIPTION: Relief, unloader and flow control valves arrangement, P and T ports open  
 TYPE: **AN2P/PPXN1(JNG3-120)ELN-WC-SAE** CODE: Y61S3A7005  
 DESCRIPTION: As AN2, port P open and T plugged  
 TYPE: **AN6/EEXL1(VMP02TR-220)-SB10RC(C3)-WC-SAE** CODE: Y61S3A7006  
 DESCRIPTION: With pressure relief valve and flow control valve, for Open Center circuit, compensator with 10 bar (145 psi) stand-by, P and T ports open  
 TYPE: **AN7/EEFN1(VMP02TR-200)-SB10RCV(C3)-WC-SAE** CODE: Y61S3A7007  
 DESCRIPTION: As previous one, compensator with handwheel actuation for Open to Closed Center switching, P and T ports open.  
 TYPE: **AN11/EEFN1(VMP02TR-200)-SB10RCV(C3)-WC-SAE** CODE: Y61S3A307008  
 DESCRIPTION: With pressure relief valve and flow control valve, for Closed Center Circuit with compensator blanking plug, P and T ports open.

**2 Complete working section \* page 16**

Section bodies are cast iron made

TYPE: **Q-18ES3B-WC-SAE** CODE: Y63S3A7001  
 DESCRIPTION: Parallel circuit, type 1 double acting spool  
 TYPE: **Q-28ES3B-WC-SAE** CODE: Y63S3A7006  
 DESCRIPTION: Parallel circuit, type 2 double acting spool  
 TYPE: **QBP-18ES3B.BPC3-WC-SAE** CODE: Y63S3A7002  
 DESCRIPTION: Parallel circuit, type 1 double acting spool, check valves on workports  
 TYPE: **QBPE-18ES3B.BPEN(NC)3-WC-SAE** CODE: Y63S3A7005  
 DESCRIPTION: Parallel circuit, type 1 double acting spool, solenoid operated check valves on workports  
 TYPE: **PFL3(150)-18ES3B-WC-SAE** CODE: Y63S3A7011  
 DESCRIPTION: Parallel circuit, type 1 double acting spool and side relief valve with 150 bar (2175 psi)  
 TYPE: **QL-18ES3B-WC-SAE** CODE: Y63S3A7004  
 DESCRIPTION: Parallel circuit, side workports, type 1 double acting spool  
 TYPE: **QBPL-18ES3B.BPA3-WC-SAE** CODE: Y63S3A7003  
 DESCRIPTION: As previous one with check valves on workports

**3 Complete outlet section\* page 25**

Section bodies are aluminium alloy made

TYPE	CODE	DESCRIPTION
<b>RF</b>	3FIA203000	Without ports
<b>RS-SAE</b>	6193A5200	P and T ports plugged
<b>RP-SAE</b>	6193A5100	P port open and T port plugged
<b>RT-SAE</b>	6193A5000	T port open and P port plugged

**4 Valve threading**

Specify threading always when it is different from BSP standard (see page 4).

**5 Coils page 58**

Coils voltage specification; for list of available coils see pages of related sections

**6 Fixing bracket page 61**

TYPE	CODE	DESCRIPTION
<b>STAF</b>	5STA148065	Brackets with fixing screws

**7 Assembling kit**

CODE	DESCRIPTION	CODE	DESCRIPTION
<b>Per distributore con fiancata d'ingresso tipo AN</b>			
5TIR108116	For 1 section valve	5TIR108305	For 6 sections valve
5TIR108154	For 2 sections valve	5TIR108341	For 7 sections valve
5TIR108194	For 3 sections valve	5TIR108377	For 8 sections valve
5TIR108227	For 4 sections valve	5TIR108412	For 9 sections valve
5TIR108264	For 5 sections valve	5TIR108449	For 10 sections valve
<b>Per distributore con fiancate d'ingresso tipo AN1-AN2-AN6-AN7-AN11</b>			
5TIR108154	For 1 section valve	5TIR108341	For 6 sections valve
5TIR108194	For 2 sections valve	5TIR108377	For 7 sections valve
5TIR108227	For 3 sections valve	5TIR108412	For 8 sections valve
5TIR108264	For 4 sections valve	5TIR108449	For 9 sections valve
5TIR108305	For 5 sections valve	5TIR108486	For 10 sections valve

NOTE (\*) – Codes are referred to **UN-UNF** thread.

## Inlet section: part ordering codes

### SDE030/AN-....

1 6

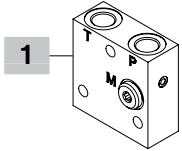

### SDE030/AN1(JNG3-120)ELN-WC-....

Valve setting (bar) Without coil

1 2 3 6

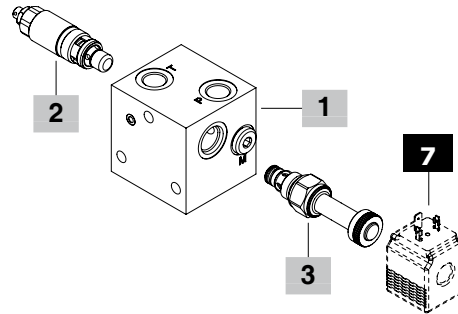

### SDE030/AN2/PPXN1(JNG3-120)ELN-WC-....

Valve setting (bar) Without coil

1 4 2 3 6

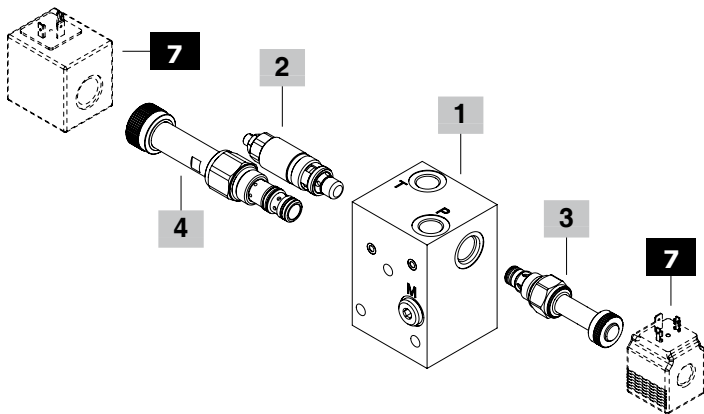

### SDE030/AN6/EEXN1(VMP02TS-200)

Valve setting (bar)

1 4 2

### SB10RCV(C3)-WC-....

5 Without coil 6

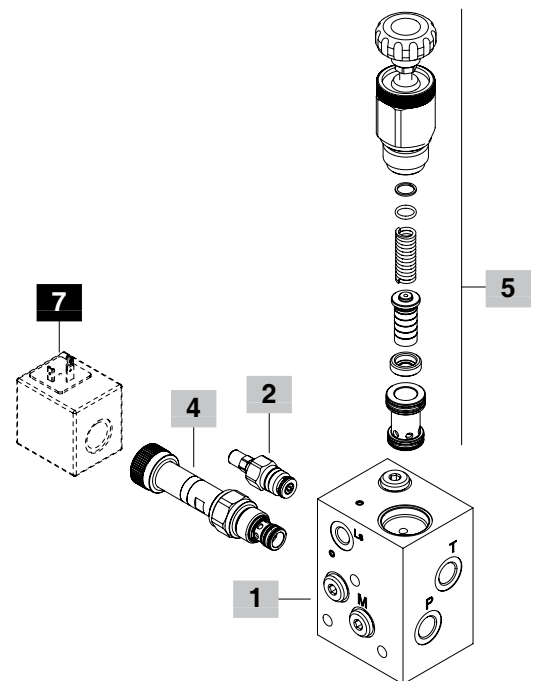



## Inlet section: part ordering codes

**1 Inlet section body kit \* page 10**

Section bodies are aluminium alloy made

TYPE	CODE	DESCRIPTION
<b>AN-SAE</b>	5FIA109703	Without valves arrangement, P and T ports open
<b>ANP-SAE</b>	5FIA109703PT	As AN, port P open and T plugged
<b>ANT-SAE</b>	5FIA109703PT	As AN, port P plugged and T open
<b>ANS-SAE</b>	5FIA109703S	As AN, ports P and T plugged
<b>AN1-SAE</b>	5FIA109700	Relief and unloader valves arrangement, P and T ports open
<b>AN1P-SAE</b>	5FIA109700P	As AN1, port P open and T plugged
<b>AN2-SAE</b>	5FIA109702	Relief, unloader and flow control valves arrangement, P and T open ports
<b>AN2P-SAE</b>	5FIA109702P	As AN2, port P open and T plugged
<b>AN6-SAE</b>	5FIA109701	For Open Center, relief and flow control valves arrangement, compensator, LS port plugged, P and T ports open
<b>AN7-AN11-SAE</b>	5FIA109704	As AN6, for Closed Center, with LS port open

**2 Main relief valve page 13**

TYPE	CODE	DESCRIPTION
<b>For sections AN1-AN2 type</b>		
Valve standard setting is referred to 10 l/min (2.6 US gpm) flow, considering the valve mounted on inlet section.		
<b>(JNG2-63)</b>	5KIT105512	Range 40-63 bar (580-900 psi) std setting 63 bar (900 psi)
<b>(JNG3-120)</b>	5KIT105513	Range 50-200 bar (725-2900 psi) std setting 120 bar (1750 psi)
<b>(JNG4-220)</b>	5KIT105514	Range 160-315 bar (2300-4600 psi) std setting 220 bar (3200 psi)
<b>(JNH2-63)</b>	5KIT105517	As type JNG2, set and locked
<b>(JNH3-120)</b>	5KIT105516	As type JNG3, set and locked
<b>(JNH4-220)</b>	5KIT105515	As type JNG4, set and locked
<b>(JNZT2-63)</b>	5KIT105562	As type JNG2, anti-tampering type
<b>(JNZT3-120)</b>	5KIT105563	As type JNG3, anti-tampering type
<b>(JNZT4-220)</b>	5KIT105564	As type JNG4, anti-tampering type
<b>SV</b>	XTAP623282	Relief valve blanking plug

**For sections AN6-AN7-AN11 type**

Valve standard setting is referred to 1 l/min (0.26 US gpm) flow, considering the valve mounted on inlet section.

<b>(VMP02TV-50)</b>	1100000100	Range 5-80 bar (73-1160 psi) std setting 50 bar (725 psi)
<b>(VMP02TS-150)</b>	1100000101	Range 50-220 bar (725-3200 psi) std setting 150 bar (2200 psi)
<b>(VMP02TR-250)</b>	1100000102	Range 180-350 bar (2600-5100 psi) std setting 250 bar (3600 psi)

**3 Solenoid operated unloading valve page 14**

TYPE	CODE	DESCRIPTION
<b>For sections AN1-AN2 type</b>		
<b>ELN</b>	0EC08002031	Without emergency actuation
<b>ELV</b>	0EC08002034	With screw type emergency actuation
<b>ELP</b>	0EC08002033	With push-button emergency actuation
<b>ELT</b>	0EC08002035	With "twist & push" emergency actuation
<b>LT</b>	XTAP510320	Unloading valve blanking plug

**4 Flow control valve page 14**

TYPE	CODE	DESCRIPTION
<b>For sections AN1-AN2 type</b>		
<b>PPAL1</b>	OPP10002000	Hand-wheel setting type
<b>PPAV1</b>	OPP10002005	Screw setting type
<b>PPXN1</b>	OPP10002031	Solenoid operated, without emergency
<b>PPXV1</b>	OPP10002033	Solenoid operated, screw emergency
<b>PPXL1</b>	OPP10002035	Solenoid operated, hand-wheel emergency
<b>LT</b>	3XTP3545700	Flow control valve blanking plug
<b>For sections AN6-AN7-AN11 type</b>		
<b>EEXN1</b>	0EE10002009	Solenoid operated, without emergency
<b>EEXL1</b>	0EE10002008	Solenoid operated, hand-wheel emergency

**5 Compensator kit page 15**

TYPE	CODE	DESCRIPTION
<b>For section AN6-AN7 type</b>		
<b>SB10RCV(C3)</b>	5KT6200227	With 10 bar (145 psi) stand-by, hand-wheel actuation for Open Center to Closed Center switching
<b>SB10RC(C3)</b>	5KT6200222	With 10 bar (145 psi) stand-by, for Open Center circuit
<b>For section AN11 type</b>		
<b>CL</b>	X451810000	Compensator blanking plug, for Closed Center circuit

**6 Section threading**

Specify threading always when it is different from BSP standard (see page 4).

**7 Optional coil pag. 58**

For list of available coils see pages of related section.

NOTE (\*) – Codes are referred to **UN-UNF** thread.

Inlet section: dimension and hydraulic circuit

AN inlet sections

AN type with P and T ports open

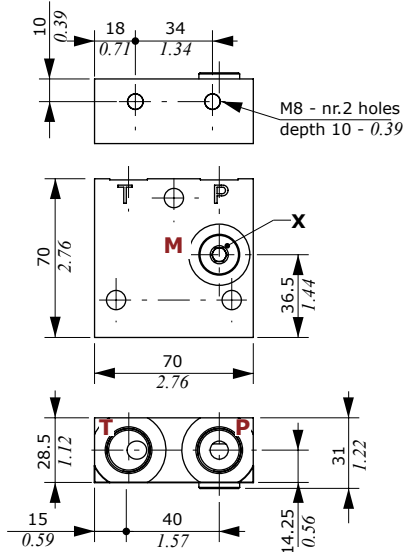

AN type P and T ports open

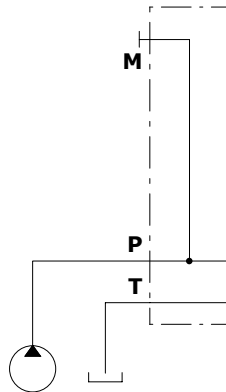

ANP type P port open and T port plugged

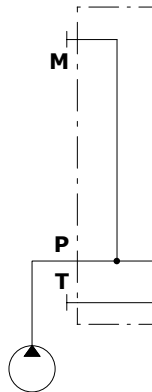

ANT type P port plugged and T port open

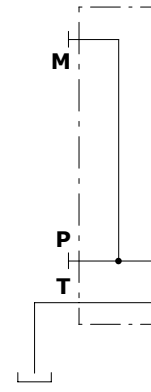

ANS type P and T ports plugged

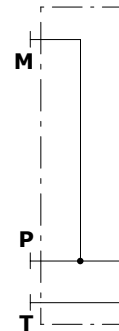

Wrenches and tightening torque  
X = allen wrench 6 - 24 Nm (17.7 lbft)

AN1 inlet sections

AN1 type with P and T ports open

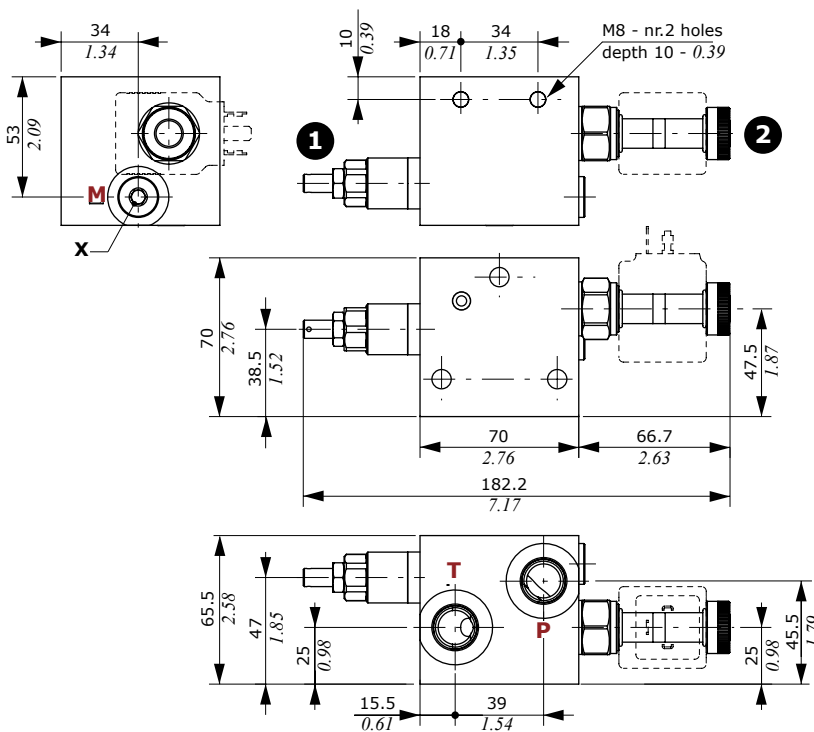

AN1 types P and T ports open

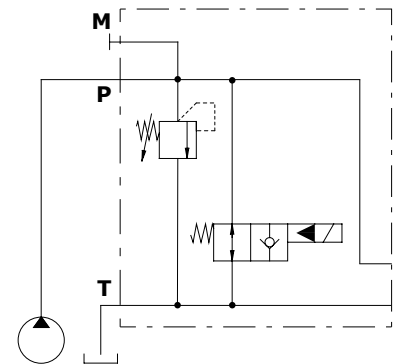

AN1P types

P port open and T port plugged

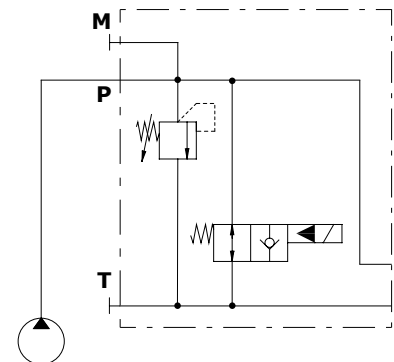

Wrenches and tightening torque  
X = allen wrench 6 - 24 Nm (17.7 lbft)  
NOTE: for valve wrench and torque see pages 13 and 14.

Legenda  
1: Pressure relief valve  
2: Solenoid operated unloading valve

Inlet section: dimension and hydraulic circuit

AN2 inlet sections

AN2 type with P and T ports open

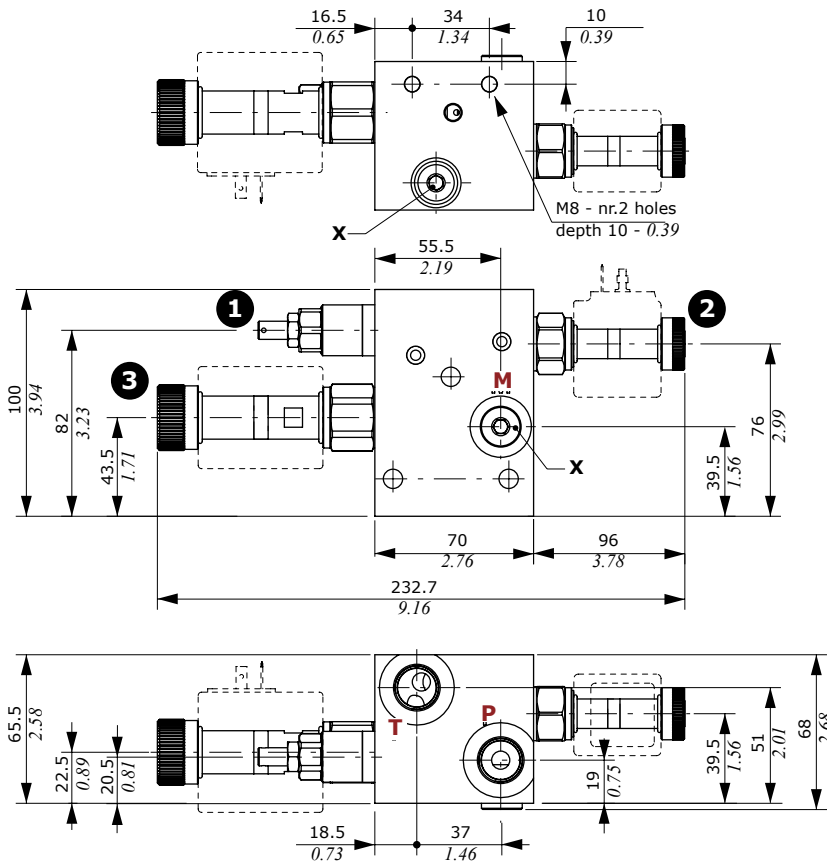

AN2 types  
P and T ports open

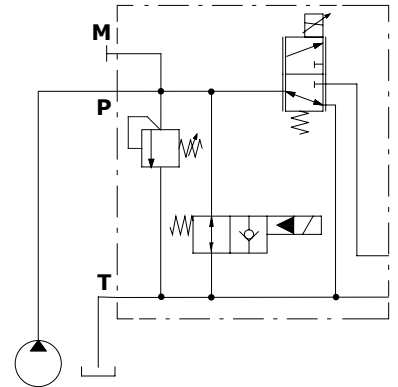

AN2P types  
P port open and T port plugged

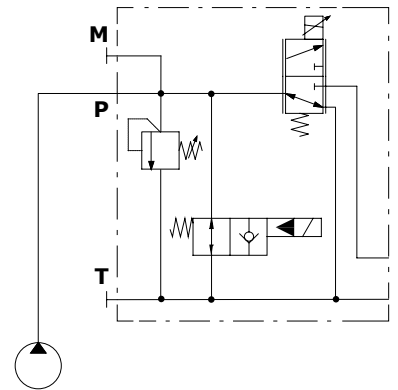

Legenda

- 1: Pressure relief valve
- 2: Solenoid operated unloading valve
- 3: Pressure compensated flow control valve

Wrenches and tightening torque

X = allen wrench 6 - 24 Nm (17.7 lbf<sub>t</sub>)  
NOTE: for valve wrench and torque see pages 13, 14.

Inlet section: dimension and hydraulic circuit

AN6-AN7-AN11 inlet sections

AN7 type; configuration for Open and Closed Center

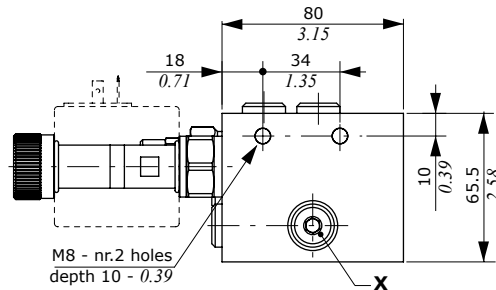

Legenda

- 1: Pressure relief valve
- 2: Flow control valve
- 3: Excludable compensator

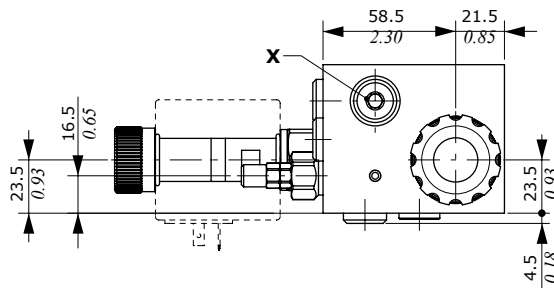
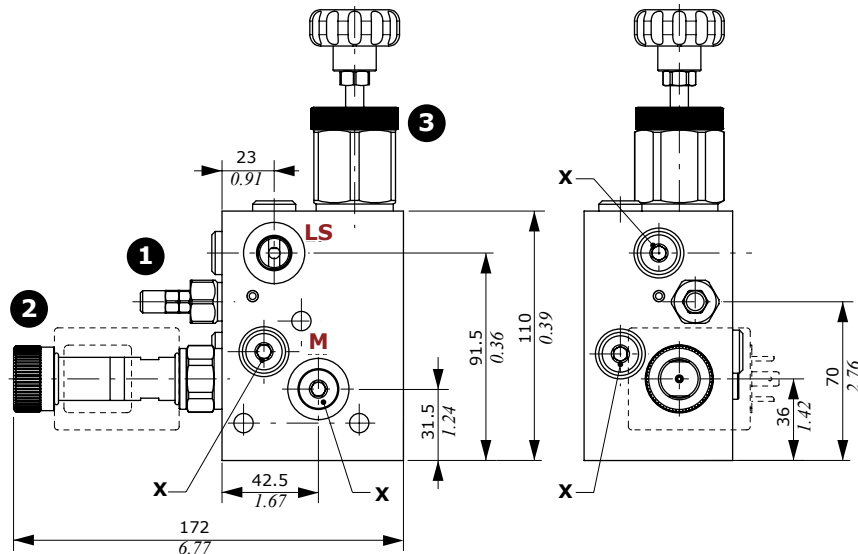
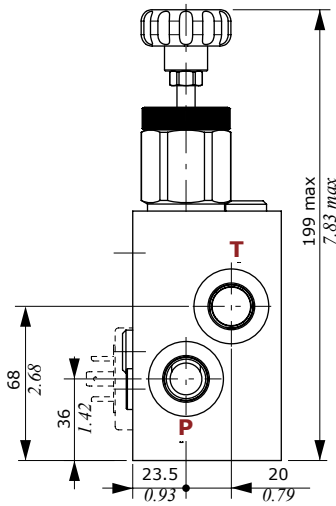

Wrenches and tightening torque

X = allen wrench 6 - 24 Nm (17.7 lbft)  
NOTE: for valve wrench and torque see pages 13 and 15.

AN6 type  
for Open Center circuit

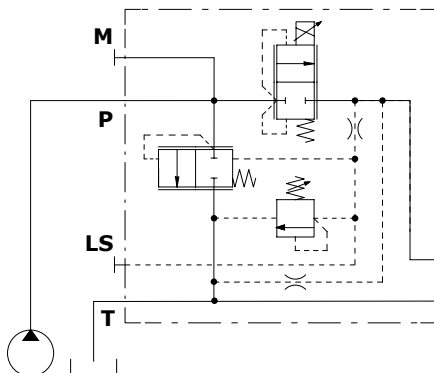

AN7 type  
for Closed and Open Center circuits

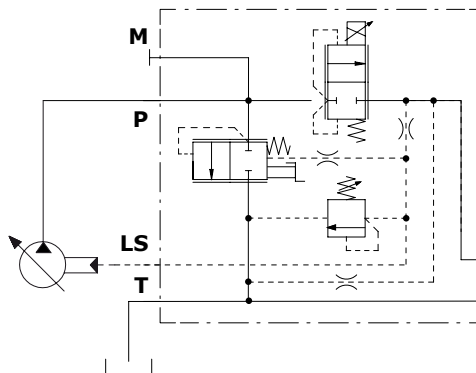

AN11 type  
for Closed Center circuit

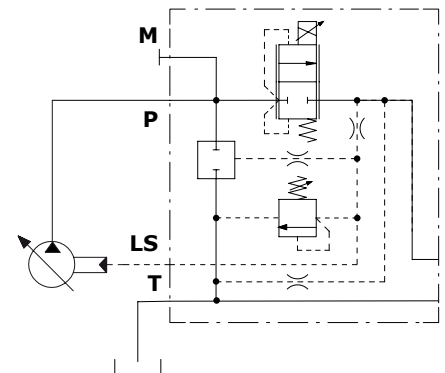

Main relief valve

For sections AN1 and AN2 type

Setting types

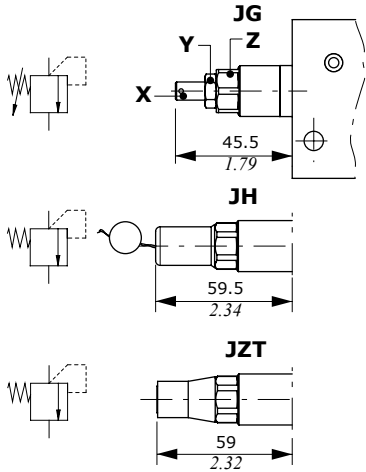

Setting range: JNG2 type

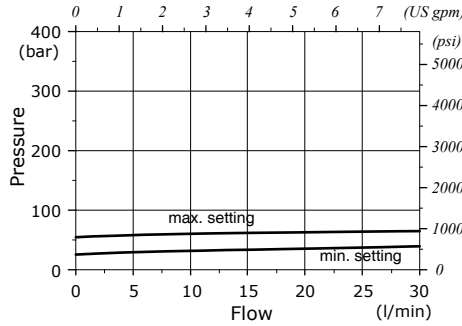

Setting range: JNG3 type

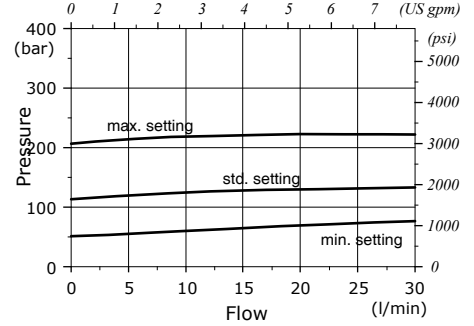

Setting range: JNG4 type

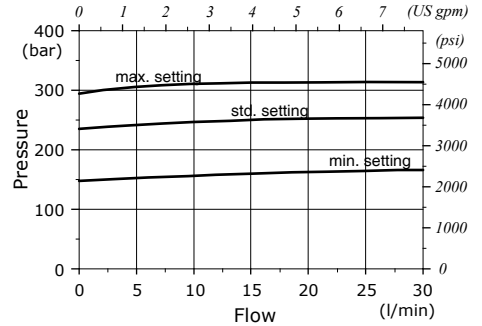

Legenda

- JG: screw setting type
- JH: valve set and locked (cap code 3COP117260)
- JZT: valve set and locked (cap code 4COP120420)

Wrenches and tightening torque

- X = allen wrench 4
- Y = wrench 13 - 24 Nm (17.7 lbft)
- Z = wrench 19 - 24 Nm (17.7 lbft)

For sections AN6 and AN7 type

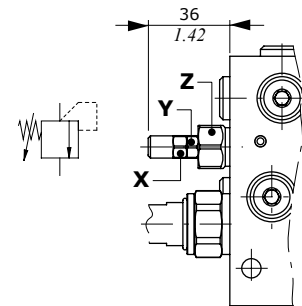

Setting range: VMP02TV type

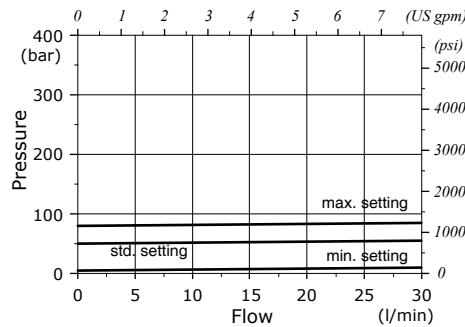

Setting range: VMP02TS type

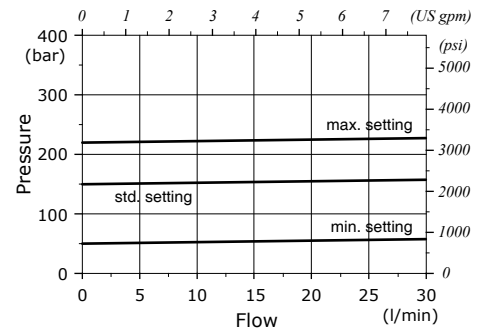

Wrenches and tightening torque

- X = wrench 10
- Y = wrench 10 - 6.6 Nm (4.9 lbft)
- Z = wrench 19 - 24 Nm (17.7 lbft)

Setting range: VMP02TR type

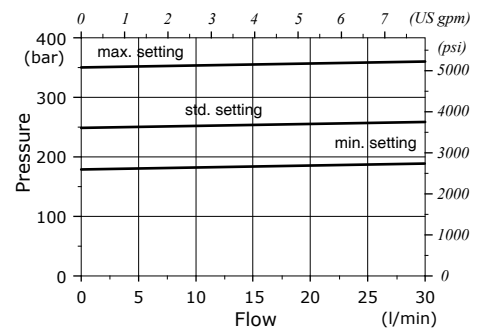

**Inlet section: options**

**Unloading valve**

For sections AN1 and AN2 type

**Emergency actuation types**

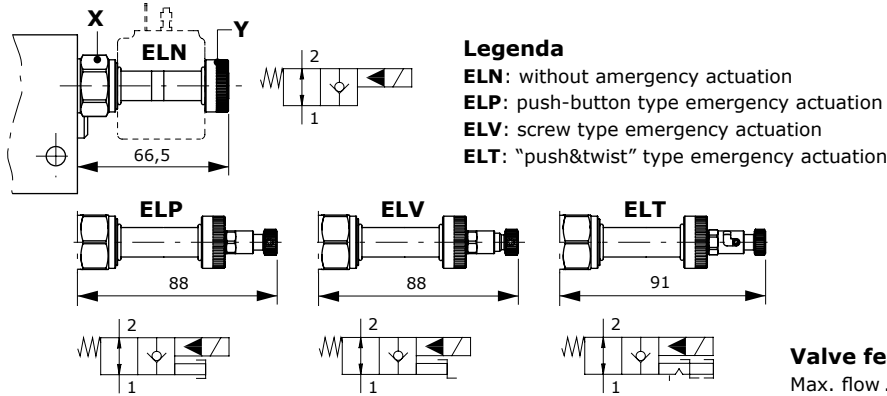

**Pressure drop diagram**

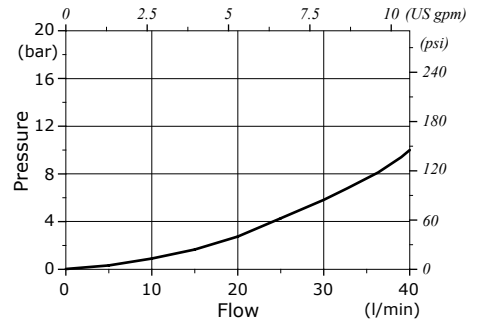

**Valve features**

Max. flow . . . . . : 40 l/min (10.6 US gpm)  
 Max. pressure . . . . . : 380 bar (5500 psi)  
 Internal leakage . . . . . : 0.25 cm<sup>3</sup>/min @ 210 bar  
 (0.015 in<sup>3</sup>/min @ 3050 psi)  
 For coil features and options see **BER** coil on pages 56 and 57.

**Wrenches and tightening torque**

X = wrench 24 - 30 Nm (22 lbf<sub>t</sub>)  
 Y = 5 Nm (3.7 lbf<sub>t</sub>)

**Pressure compensated flow control valve**

For section AN2 type

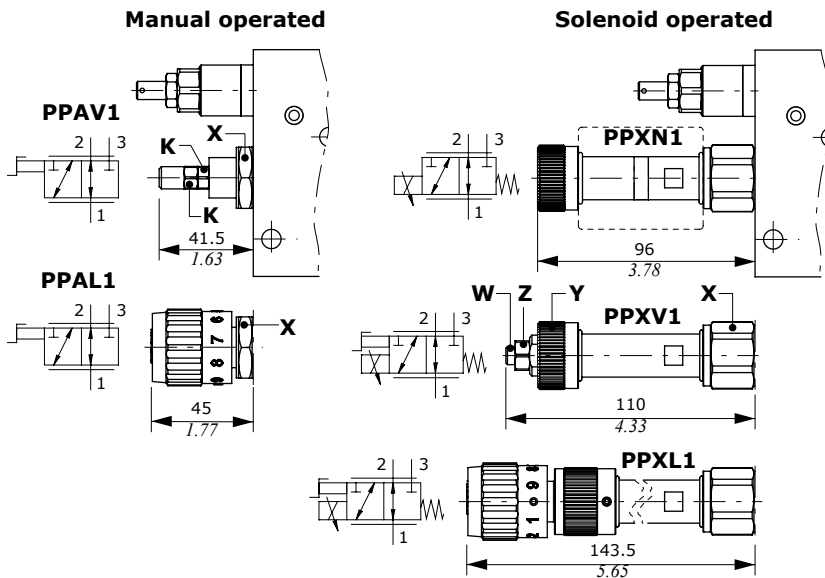

**Flow regulation diagram**

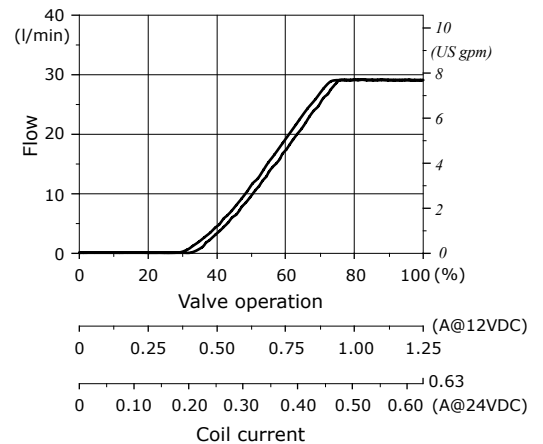

**Legenda**

**PPAV1:** screw setting type  
**PPAL1:** hand-wheel setting type  
**PPXN1:** without emergency actuation  
**PPXV1:** screw type emergency actuation  
**PPXL1:** hand-wheel emergency actuation

**Wrenches and tightening torque**

K = wrench 10 - 6.6 Nm (4.9 lbf<sub>t</sub>)  
 X = wrench 27 - 50 Nm (37 lbf<sub>t</sub>)  
 Y = 5 Nm (3.7 lbf<sub>t</sub>)  
 W = allen wrench 4  
 Z = wrench 8 - 15 Nm (11 lbf<sub>t</sub>)

**Valve features**

Max. inlet flow . . . . . : 50 l/min (13.2 US gpm)  
 Max. regulated flow . . . . . : 30 l/min (7.9 US gpm)  
 Inlet flow (PPX types) . . . . . : regulated flow +5%  
 Max. pressure . . . . . : 350 bar (5100 psi) - PPA types / 315 bar (4600 psi) - PPX types  
 Internal leakage (PPX types) : 150 cm<sup>3</sup>/min @ 210 bar (9.1 in<sup>3</sup>/min @ 3050 psi)  
 For coil features and options see **BQP19** or **BH** coils on pages 56 and 57.

**Flow vs. Pressure diagram**

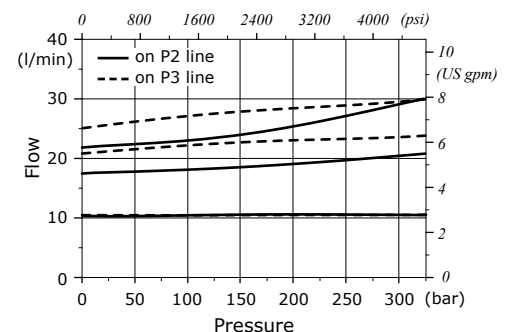

Inlet section: options

Pressure compensated flow control valve

For sections AN6-AN7-AN11 type

Curves are measured using the standard compensator mounted on section, with 10 bar (145 psi) stand-by.

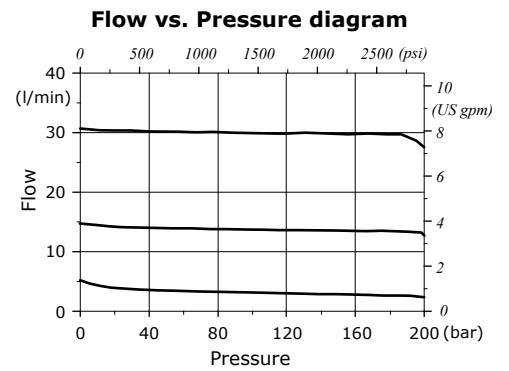
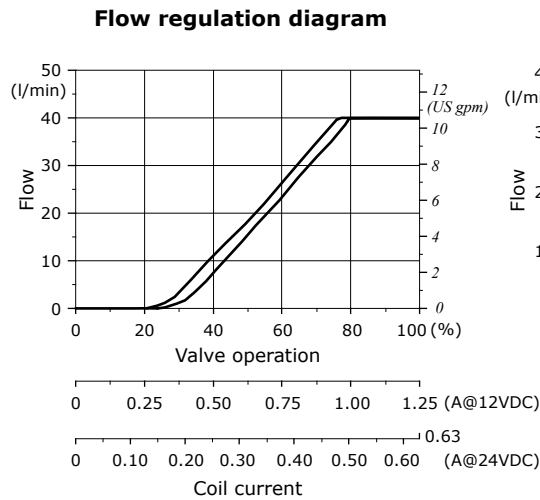
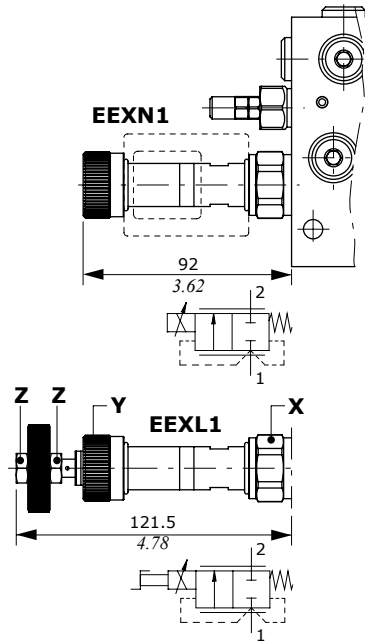

Legenda

- EEXN1: without emergency actuation
- EEXL1: hand-wheel emergency actuation

Wrenches and tightening torque

- K = wrench 10 - 6.6 Nm (4.9 lbft)
- X = wrench 27 - 50 Nm (37 lbft)
- Y = 5 Nm (3.7 lbft)
- Z = wrench 13 - 9.8 Nm (7.2 lbft)

Valve features

- Max. flow . . . . . : 40 l/min (10.6 US gpm)
- Max. pressure . . . . . : 300 bar (5500 psi)
- Internal leakages . . . . . : 150 cm<sup>3</sup>/min @ 150 bar (9.1 in<sup>3</sup>/min @ 2175 psi)

For coil features and options see BQP19 or BH coils on pages 56 and 57.

Compensator kit

For sections AN6-AN7-AN11 type

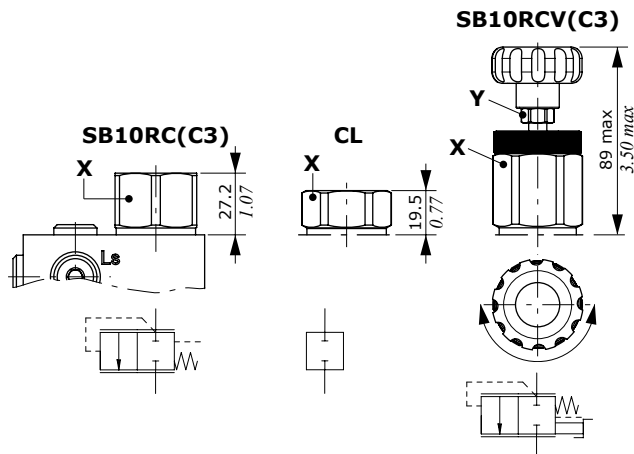

Legenda

- SB10RC(C3): compensator with 10 bar (145 psi) stand-by, for Open Center circuit
- CL: compensator blanking plug, for Closed Center circuit (for AN11 type)
- SB10RCV(C3): compensator with 10 bar (145 psi) stand-by, hand-wheel actuation for Open Center to Closed Center circuit switching

Wrenches and tightening torque

- X = wrench 36 - 42 Nm (31 lbft)
- Y = wrench 13 - 6.6 Nm (4.9 lbft)

## Working section: part ordering codes

Valve setting (bar)

**SDE030/P - 1 8ES3B.P3(G3-100) - WC - .....**

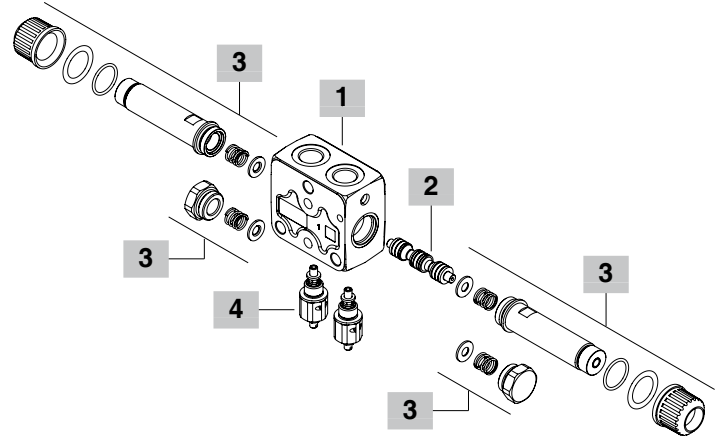
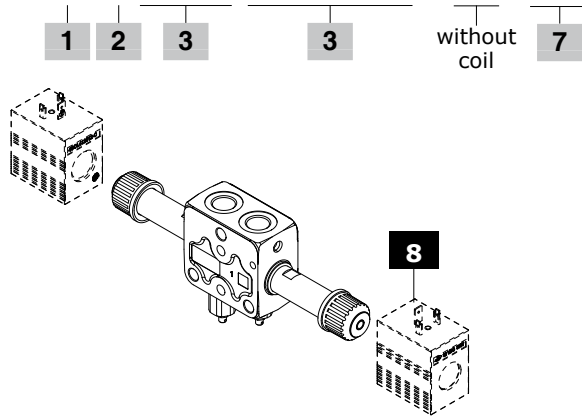

valve on port A - 1  
valve on port B - 2  
valve on ports A and B - 3

**SDE030/QBPL - 1 8ES3B.BPA 3 - WC - .....**

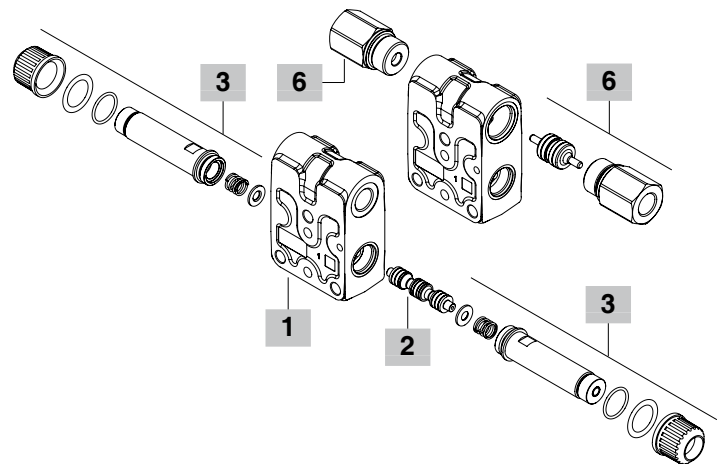
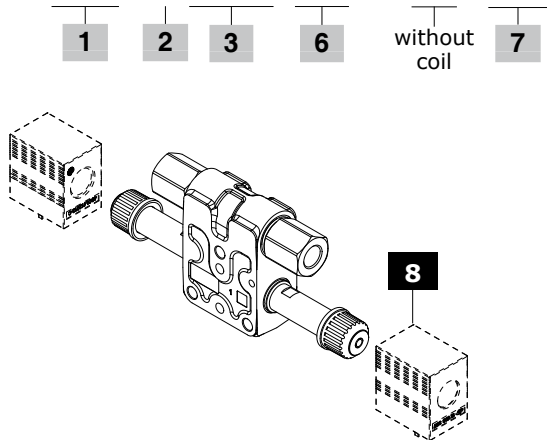

valve on port A - 1  
valve on port B - 2  
valve on ports A and B - 3

**SDE030/QBPE - 1 8ES3B.QBPEN3(NC) - WC - .....**

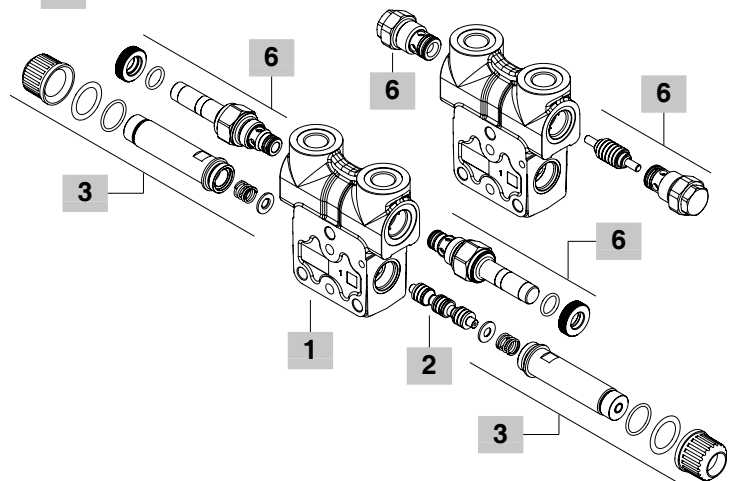
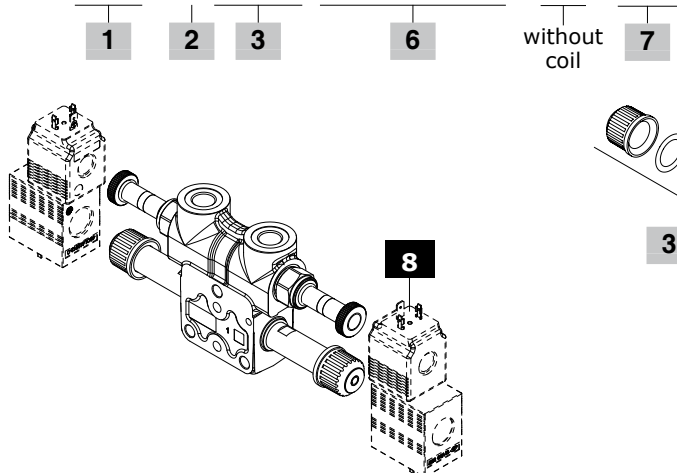



Working section: part ordering codes

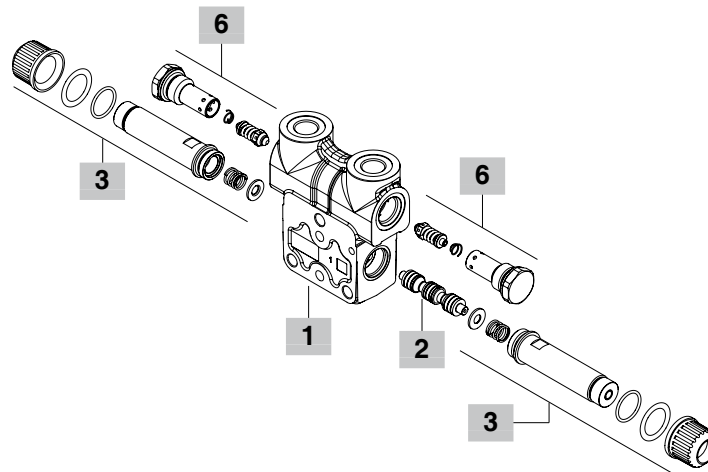
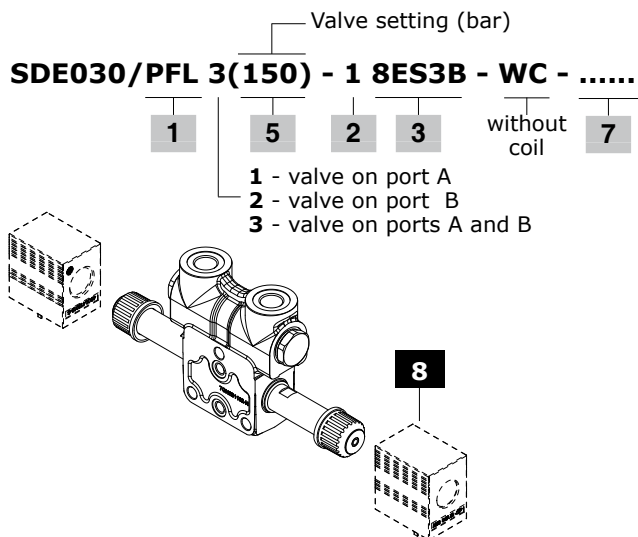

**1 Working section body kit \* page 18**

Section bodies are cast iron made

TYPE	CODE	DESCRIPTION
------	------	-------------

**Working sections with upper ports**

<b>Q-SAE</b>	5EL1097000	Parallel type, lower port relief valve arrangement
<b>P-SAE</b>	5EL1097005	As type Q, lower port relief valve arrangement
<b>QBP-SAE</b>	5EL1097003	As type Q with check valve arrangement
<b>QBPE-SAE</b>	5EL1097004	As type Q with solenoid operated check valve arrangement
<b>PFL-SAE</b>	5EL1093006	As type Q, side port relief valve arrangement

**Working sections with side ports**

<b>QL-SAE</b>	5EL1097002	Parallel type,
<b>QBPL-SAE</b>	5EL1097001	As type QL with check valve arrangement

**2 Spool page 20**

TYPE	CODE	DESCRIPTION
------	------	-------------

**For ON/OFF solenoid control**

<b>1</b>	3CU9010102	Double acting, A and B closed in neutral pos.
<b>1A</b>	3CU9010103	Double acting, A to tank in neutral pos. For connect B to tank (type <b>1B</b> ) is necessary to turn the spool
<b>2</b>	3CU9025100	Double acting, A and B to tank in neutral pos.
<b>2H</b>	3CU9025225	Double acting, A and B partially to tank in neutral position

**For ON/OFF solenoid control with emergency lever operation**

<b>1LHD</b>	3CU9010300	As type 1
<b>1ALHD</b>	3CU9010303	As type 1A
<b>2LHD</b>	3CU9020300	As type 2
<b>2HLHD</b>	3CU9020310	As type 2H

**3 On/off solenoid control page 21**

TYPE	CODE	DESCRIPTION
------	------	-------------

<b>8ES1B</b>	5CAN08E114C	Single acting on port A
<b>8ES2B</b>	5CAN08E114C	Single acting on port B
<b>8ES3B</b>	5CAN08E115C	Double acting
<b>8ES3BLHD</b>	5CAN08E315	Double acting with emergency lever operation: <b>needs dedicated spools</b>

**4 Lower port relief valves page 22**

Standard setting is referred to 10 l/min (2.6 US gpm) flow.

TYPE	CODE	DESCRIPTION
------	------	-------------

<b>P(G3-100)</b>	5KIT060000	From 50 to 200 bar (725 to 2900 psi), standard setting 100 bar (1450 psi)
<b>P(G4-200)</b>	5KIT060001	From 200 to 315 bar (2900 to 4600 psi), standard setting 200 bar (2900 psi)
<b>P3T</b>	5KIT060100	A and B ports valve blanking plugs

**5 Side port relief valve page 22**

The codes are referred to parts with FPM o-ring seals

TYPE	CODE	DESCRIPTION
------	------	-------------

**PT** 5TAP324460 Valve blanking plug

**Fixed setting antishock valves:**

setting is referred to 10 l/min (2.6 US gpm)

TYPE: **P 100** CODE: 5KIT308 100 A

setting (bar) setting (bar)

40 bar (580 psi)	50 bar (725 psi)	60 bar (870 psi)
80 bar (1150 psi)	100 bar (1450 psi)	120 bar (1750 psi)
130 bar (1900 psi)	140 bar (2050 psi)	150 bar (2150 psi)
165 bar (2400 psi)	175 bar (2550 psi)	185 bar (2700 psi)
200 bar (2900 psi)	210 bar (3050 psi)	220 bar (3200 psi)
235 bar (3400 psi)	250 bar (3600 psi)	

**6 Check valve page 23**

TYPE	CODE	DESCRIPTION
------	------	-------------

**For arranged sections with upper ports, QBP type**

<b>BPC3</b>	5KIT430030	Valves kit for A and B ports
<b>BPC1-BPC2</b>	5KIT430012	Valve kit por single port

**For arranged sections with upper ports, QBPE type**

<b>TBP</b>	3XTAP822150	Valve blanking plug
------------	-------------	---------------------

**Normally closed circuit (NC)**

<b>BPEN(NC)</b>	0EC08002032	Without manual emergency
<b>BPEV(NC)</b>	0EC08002037	With screw type emergency
<b>BPEP(NC)</b>	0EC08002036	With pull-button emergency
<b>BPET(NC)</b>	0EC08002038	With "pull & twist" emergency

**Normally open circuit (NO)**

<b>BPEN(NA)</b>	0EC08002031	Without manual emergency
<b>BPEV(NA)</b>	0EC08002034	With screw type emergency
<b>BPEP(NA)</b>	0EC08002033	With push-button emergency
<b>BPET(NA)</b>	0EC08002035	With "push & twist" emergency

**For arranged sections with side ports, QBPL type**

<b>BPA3-SAE</b>	5KIT430230	Valves kit for A and B ports
<b>BPA1-SAE</b>	5KIT430212	Valve kit for A port
<b>BPA2-SAE</b>	5KIT430212	Valve kit for B port

**7 Section threading**

Specify threading always when it is different from BSP standard (see page 4).

**8 Optional coils page 58**

For list of available coils see pages of related section.

NOTE (\*) - Codes are referred to **UN-UNF** thread.

Working section

Dimension and hydraulic circuit

Working section Q type with upper ports

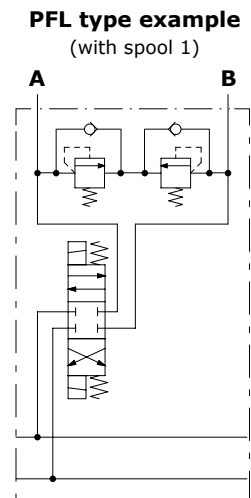
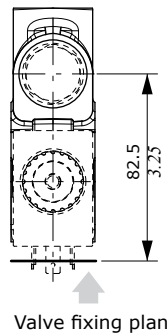
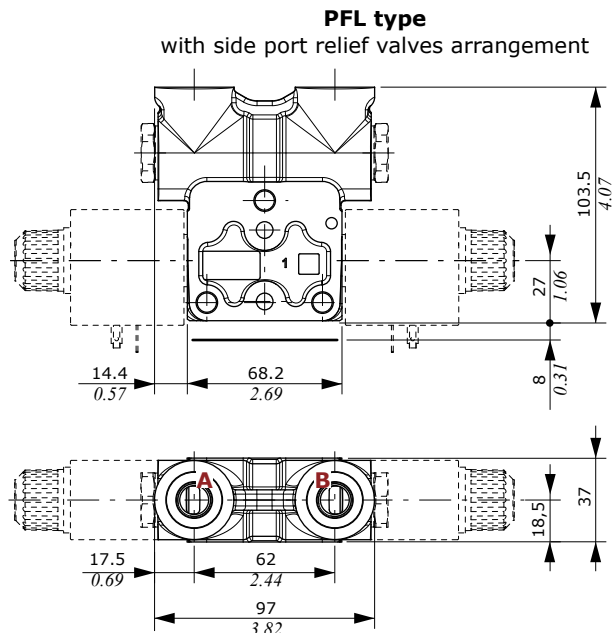
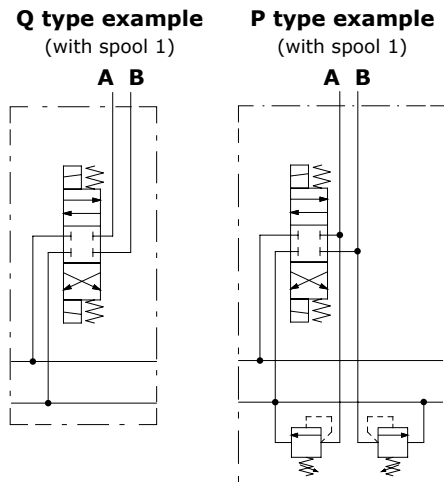
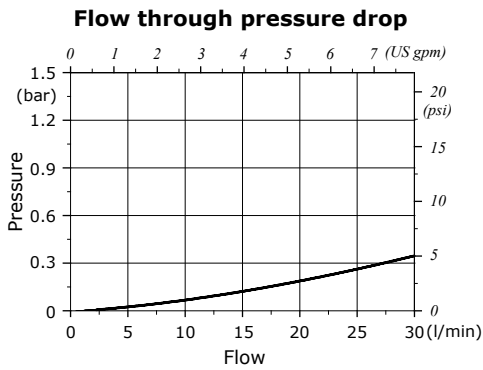
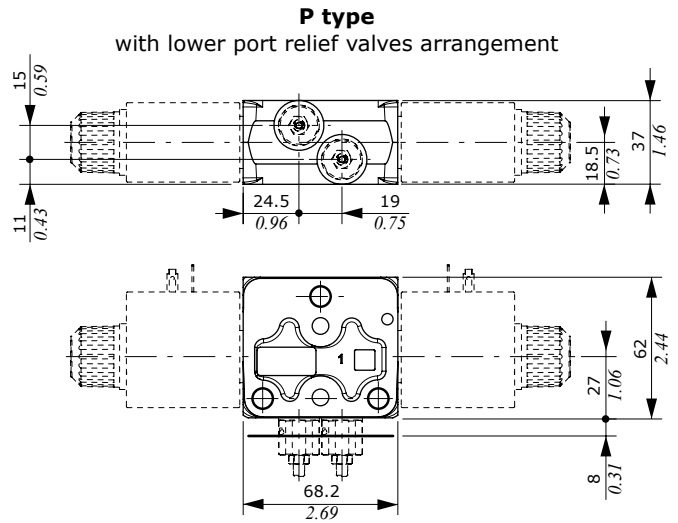
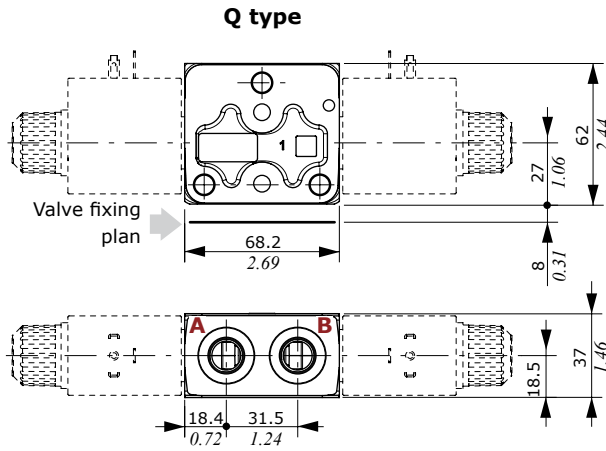

Spools

Working section with side ports

**QBP - QBPE types**  
with check valve arrangement

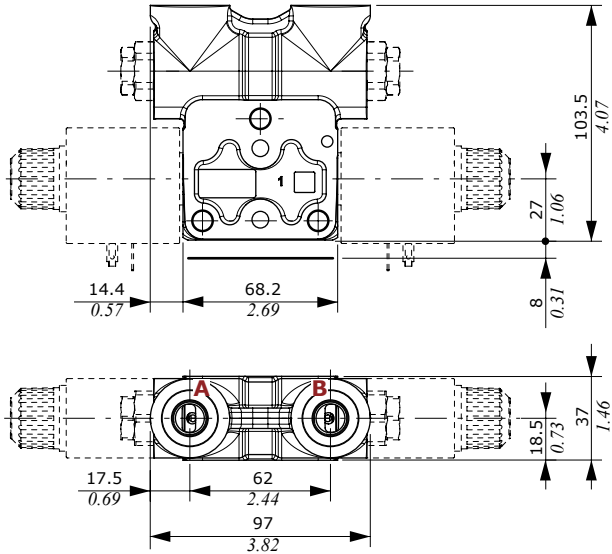

**QBP type example**  
(with spool 1)

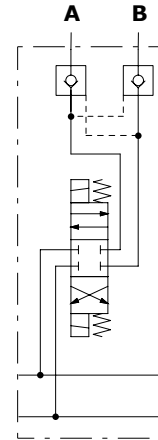

Working section with side ports

**QL - QBPL types**  
with or without check valves arrangement

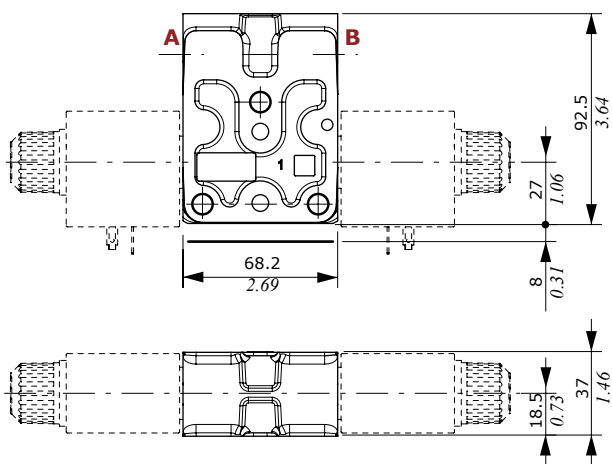

**QBPL type example**  
(with spool 1)

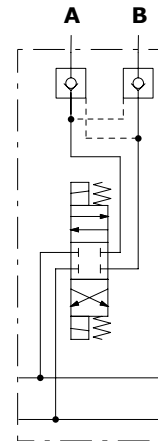
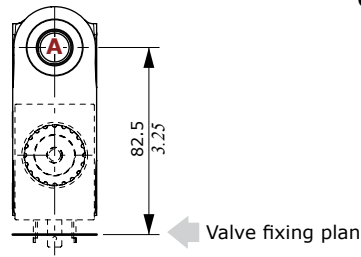

Working section

Spool

**Types 1-1LHD**

Double acting, A and B closed in neutral position

1 0 2

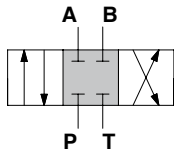

Stroke

position 1: + 3 mm (+ 0.12 in)  
position 2: - 3 mm (- 0.12 in)

**Types 1A-1ALHD**

Double acting, A to tank in neutral position

1 0 2

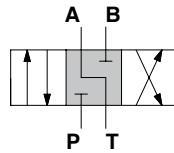

Stroke

position 1: + 3 mm (+ 0.12 in)  
position 2: - 3 mm (- 0.12 in)

**Types 2-2LHD**

Double acting, A and B to tank in neutral position

1 0 2

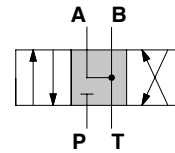

Stroke

position 1: + 3 mm (+ 0.12 in)  
position 2: - 3 mm (- 0.12 in)

**P⇒port - port⇒T pressure drops**  
(curves are matched)

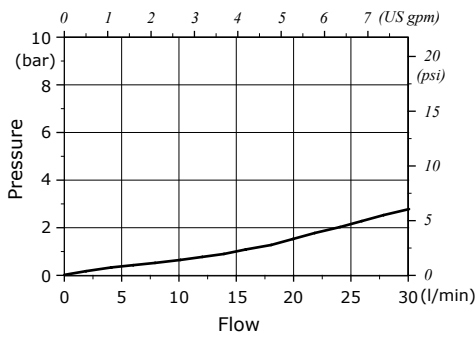

**P⇒port - port⇒T pressure drops**  
(curves are matched)

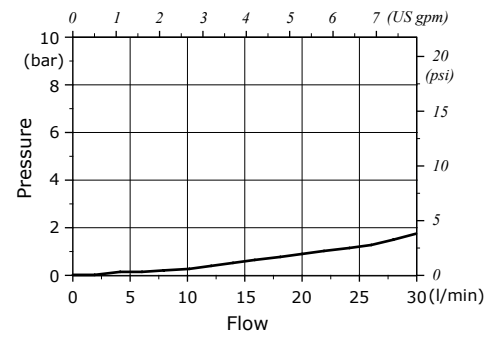

**Types 2H-2HLHD**

Double acting, A and B partially to tank in neutral position

1 0 2

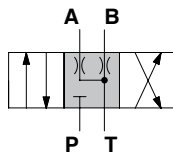

Stroke

position 1: + 3 mm (+ 0.12 in)  
position 2: - 3 mm (- 0.12 in)

**P⇒port - port⇒T pressure drops**  
(curves are matched)

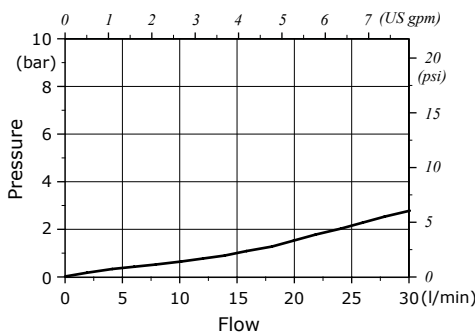

**On/off solenoid control: 8ES3B - 8ES1B - 8ES2B types**

When the section is configured with check valves, the coils on control must be rotated 180°.

**8ES3B: double acting control kit**

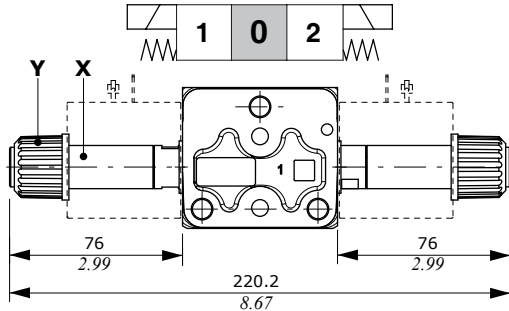

**8ES1B: single acting on A control kit**

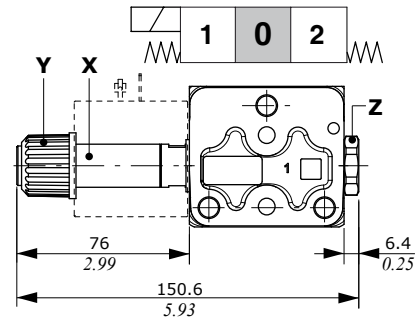

**8ES2B: single acting on B control kit**

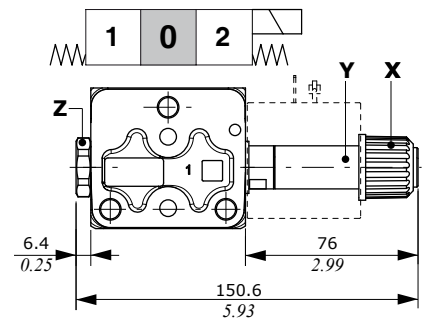

**Operating condition**  
(stroke 3 mm - 0.12 in)

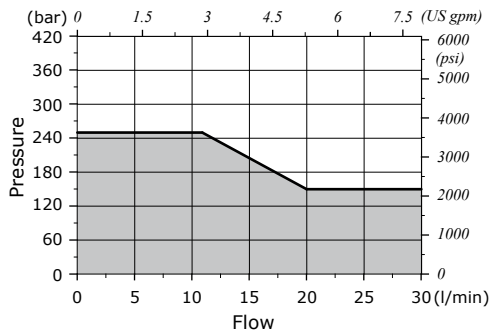

**Wrenches and tightening torque**

- X = wrench 17 - 24 Nm (17.7 lbf<sub>t</sub>)
- Y = 6.6 Nm (4.9 lbf<sub>t</sub>)
- Z = wrench 24 - 24 Nm (17.7 lbf<sub>t</sub>)

For coil features and options see **D12C** coil on pages 56 and 58.

**On/off solenoid control with lever: 8ES3BLHD type**

When the section is configured with side ports or with check valves, control and coils must be rotated 180°.

If the section is configured with solenoid check valves the control can't be used.

The control needs dedicated spools: see page 17 for list.

IMPORTANT: lever to be used only for emergency operation, not for continuative use.

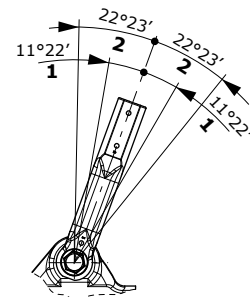
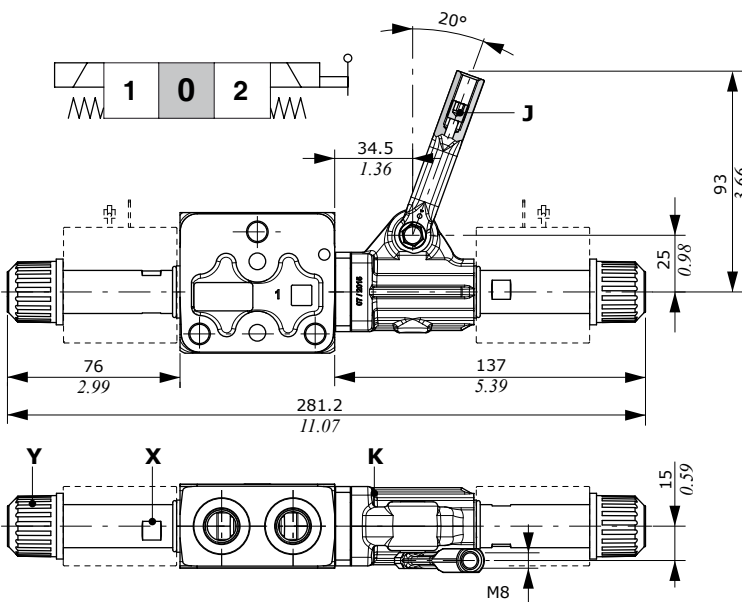

- 1: idle stroke angles
- 2: total operation angles

**Wrenches and tightening torque**

- J = wrench 4 - 9.8 Nm (7.2 lbf<sub>t</sub>)
- K = allen wrench 4 - 6.6 Nm (4.9 lbf<sub>t</sub>)
- X = wrench 17 - 24 Nm (17.7 lbf<sub>t</sub>)
- Y = 6.6 Nm (4.9 lbf<sub>t</sub>)

**Control features**

Max. back pressure on T : 30 bar (435 psi)  
For coil features and options see **D12C** coil on pages 56 and 58.

Working section

Lower port relief valves

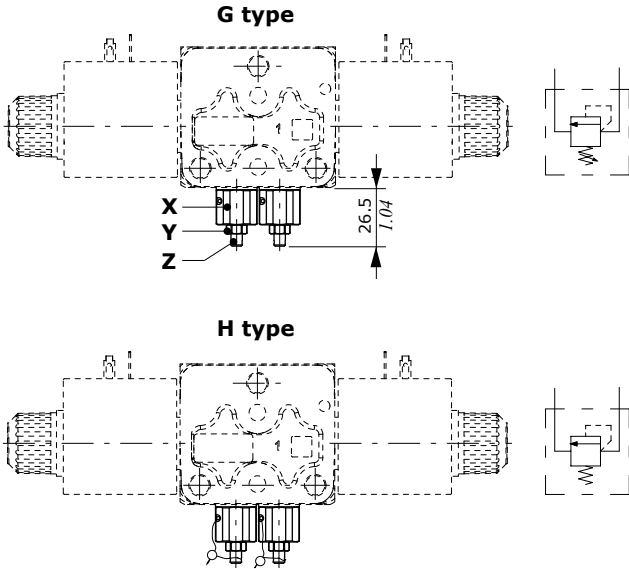

Legenda

G: screw setting type  
H: valve set and locked

Wrenches and tightening torque

X = wrench 17 - 24 Nm (17.7 lbf<sup>t</sup>)  
Y = wrench 8 - 6.6 Nm (4.9 lbf<sup>t</sup>)  
Z = allen wrench 2.5

Setting range: G3 type

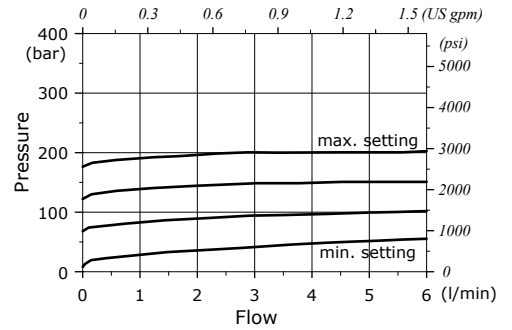

Setting range: G4 type

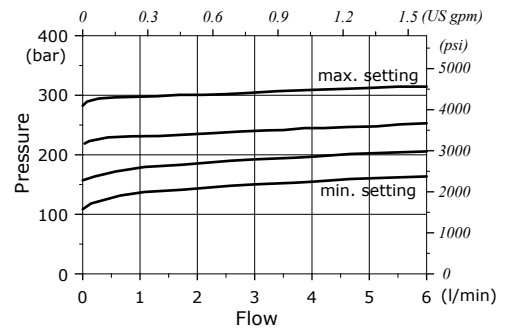

Side port relief valves

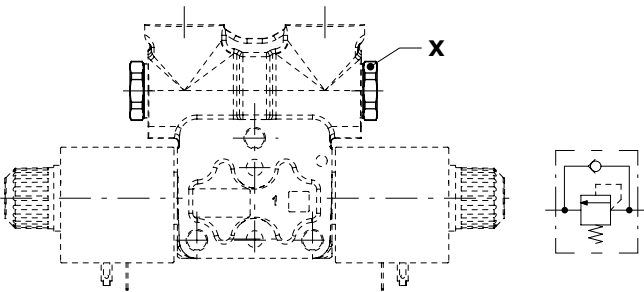

Wrenches and tightening torque

X = wrench 24 - 42 Nm (31 lbf<sup>t</sup>)

Pressure drop

(working section included)

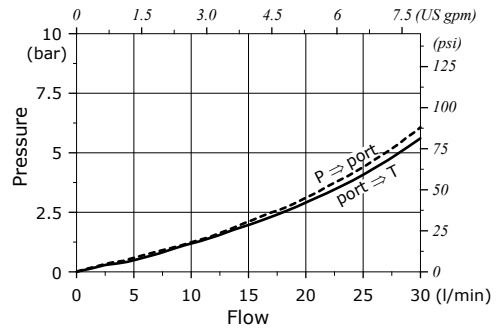

Setting example

(10 l/min - 2.6 US gpm)

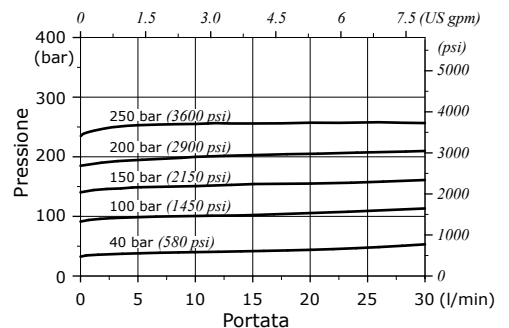

**Check valves**

When the section is configured with check valves, the coils on control must be rotated 180°.

**For sections with upper ports**

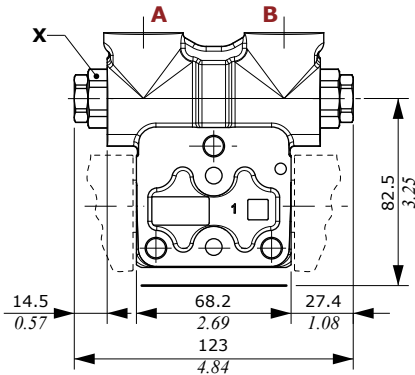

**Wrenches and tightening torque**

X = wrench 24 - 42 Nm (31 lbft)

**Parts ordering codes**

TYPE	CODE	DESCRIPTION
BP	1300020402	Check valve
TBP	XTAP627260	Valve blanking plug
-	3PIS214480	Piston

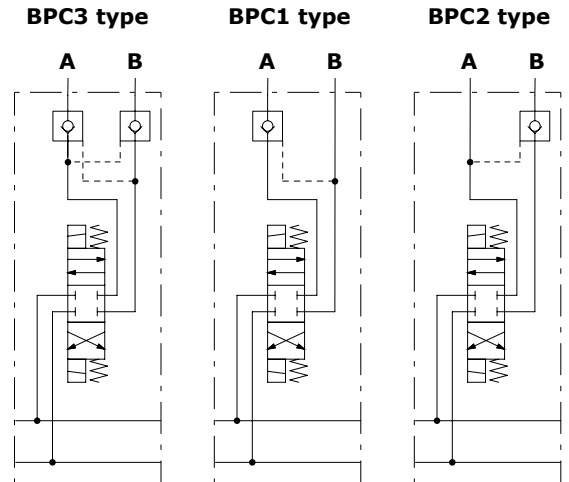

**Pressure drop diagram**  
(working section included)

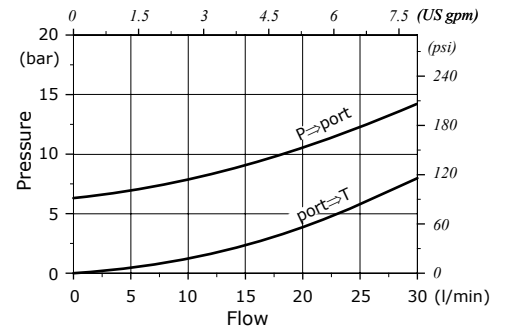

**For sections with side ports**

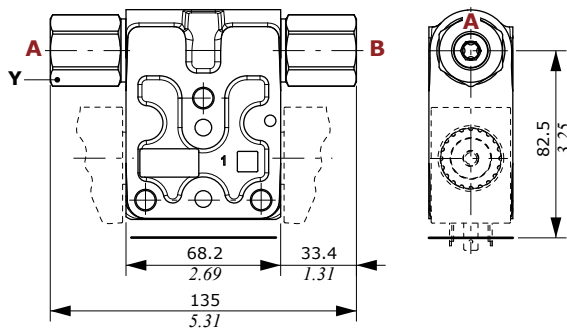

**Wrenches and tightening torque**

X = wrench 28 - 50 Nm (37 lbft)

**Parts ordering codes**

TYPE	CODE	DESCRIPTION
BPA	3XCA0422802	Check valve
-	3PIS3180460	Piston

**Pressure drop diagram**  
(working section included)

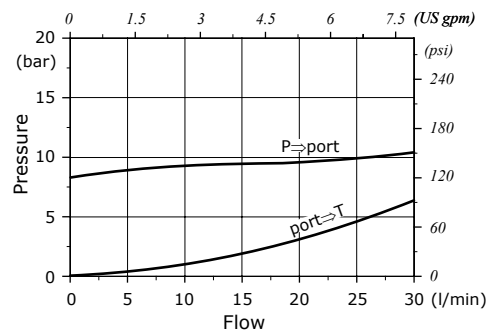

**BPA3 type**

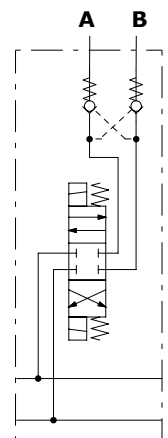

Working section

Solenoid operated check valves

When the section is configured with check valves, the coils on control must be rotated 180°.

For sections with upper ports

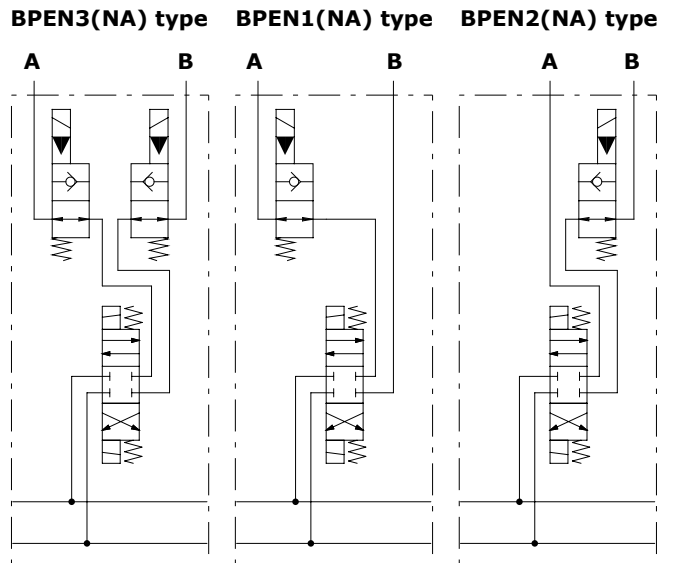
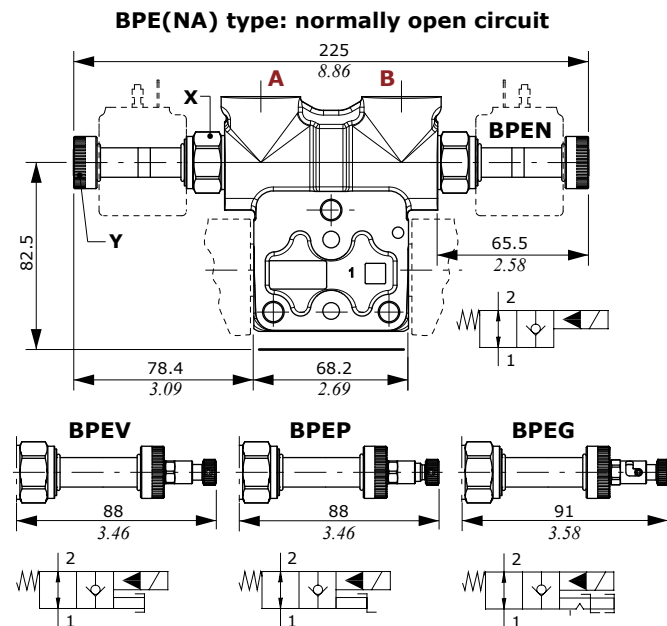
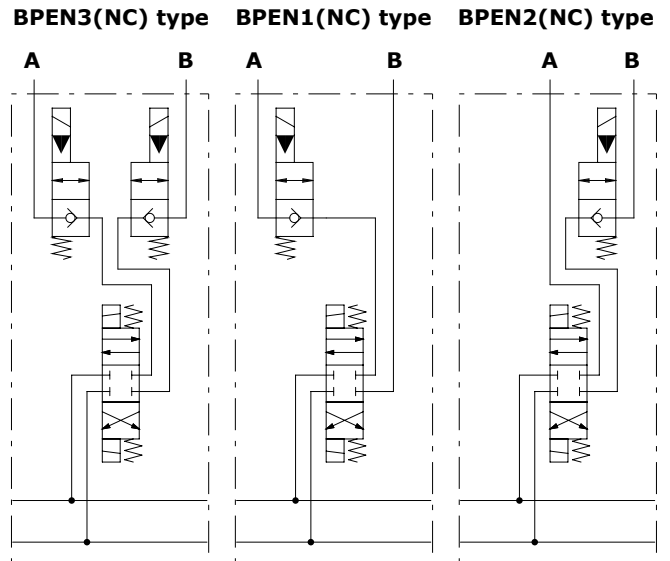
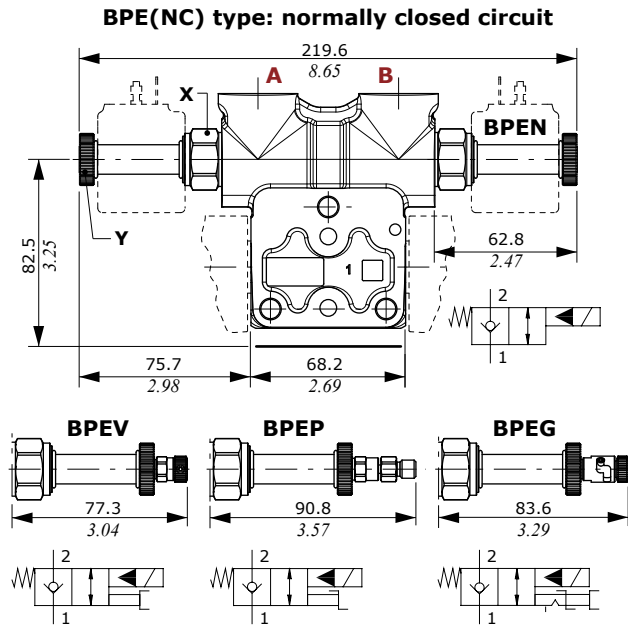

Wrenches and tightening torque

X = wrench 24 - 30 Nm (22 lbf<sub>t</sub>)

Y = 5 Nm (3.7 lbf<sub>t</sub>)

Legenda

- BPEN:** without emergency actuation
- BPEP:** push-button type emergency actuation
- BPEV:** screw type emergency actuation
- BPET:** "push&twist" type emergency actuation

Pressure drop diagram (working section included)

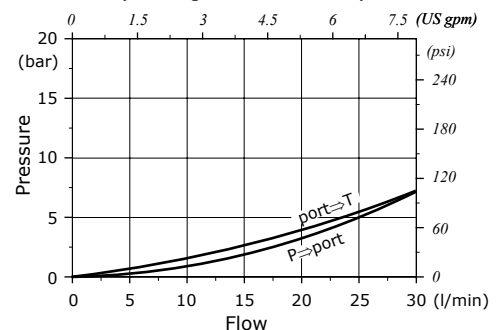



Dimensions and hydraulic circuit

Without port arrangement

RF type

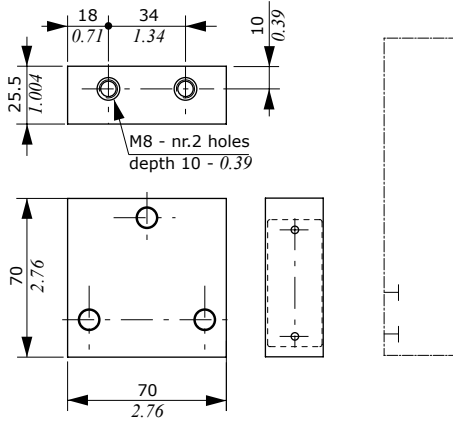

With port arrangement

RS - RP - RT types  
drawing shows RS type

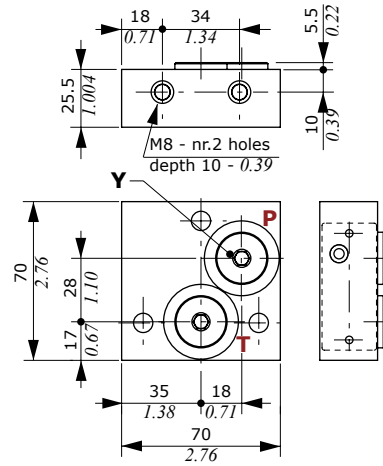

Wrenches and tightening torque

X = allen wrench 8 - 24 Nm (17.7 lbf<sub>t</sub>)  
Y = allen wrench 6 - 24 Nm (17.7 lbf<sub>t</sub>)

**RS type**  
P and T ports plugged

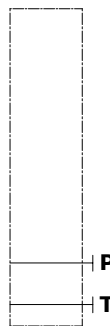

**RP type**  
P open, T plugged

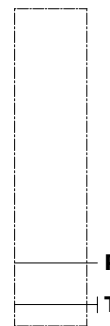

**RT type**  
T open, P plugged

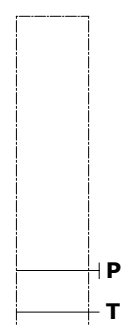



Dimensional data

This drawing is referred to directional valve with mixed working sections (2 sections up 60 to l/min-15.8 US gpm and 2 sections up to 30 l/min-7.9 US gpm), and AN1 type inlet section.

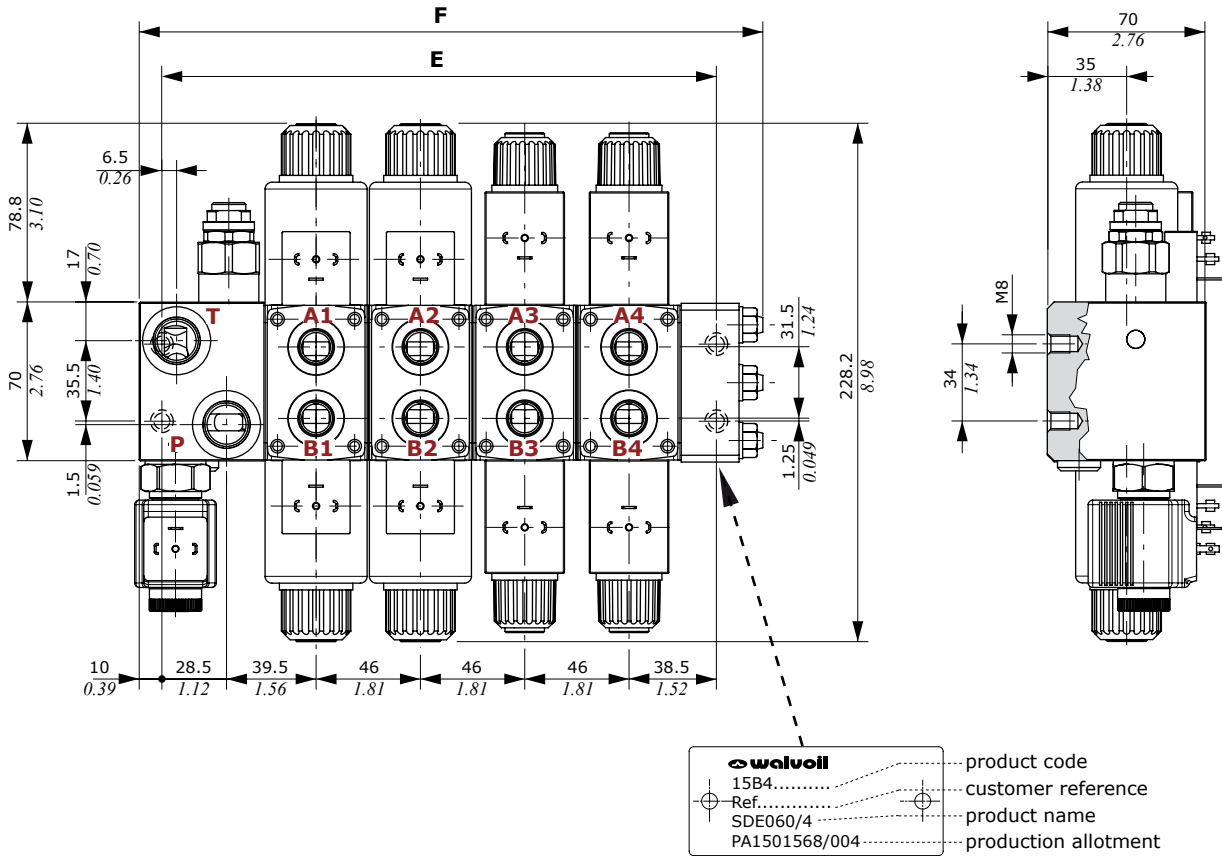

TYPE	AN type inlet section				AN1 type inlet section (see drawing)				Weight		AN2 type inlet section			
	E		F		E		F		Kg	lb	E		F	
	mm	in	mm	in	mm	in	mm	in			mm	in	mm	in
SDE060/1	83.5	3.26	116.5	4.59	106.5	4.19	139.5	5.49	5.08	11.20	137	5.12	170	6.69
SDE060/2	129.5	5.10	162.5	6.40	152.5	6.00	185.5	7.30	7.43	16.38	183	7.21	216	8.50
SDE060/3	175.5	6.91	208.5	8.21	198.5	7.82	231.5	9.11	9.78	21.56	229	9.02	262	10.31
SDE060/4	221.5	8.72	254.5	10.02	244.5	9.63	277.5	10.93	12.13	26.74	275	10.83	308	12.13
SDE060/5	267.5	10.53	300.5	11.83	290.5	11.44	323.5	12.74	14.48	31.92	321	12.64	354	13.94
SDE060/6	313.5	12.34	346.5	13.64	336.5	13.26	369.5	14.55	16.83	37.10	367	14.45	400	15.75
SDE060/7	359.5	14.15	392.5	15.45	382.5	15.06	415.5	16.36	19.18	42.28	413	16.26	446	17.56
SDE060/8	405.5	15.96	438.5	17.26	428.5	16.87	461.5	18.17	21.53	47.47	459	18.07	492	19.37
SDE060/9	451.5	17.78	484.5	19.07	474.5	18.68	507.5	19.98	23.88	52.65	505	19.88	538	21.18
SDE060/10	497.5	19.59	530.5	20.89	520.5	20.49	553.5	21.79	26.23	57.83	551	21.69	584	22.99

## Dimensional data

This drawing is referred to directional valve with all working sections up to 30 l/min (*up to 7.9 US gpm*), and N1B type inlet section.

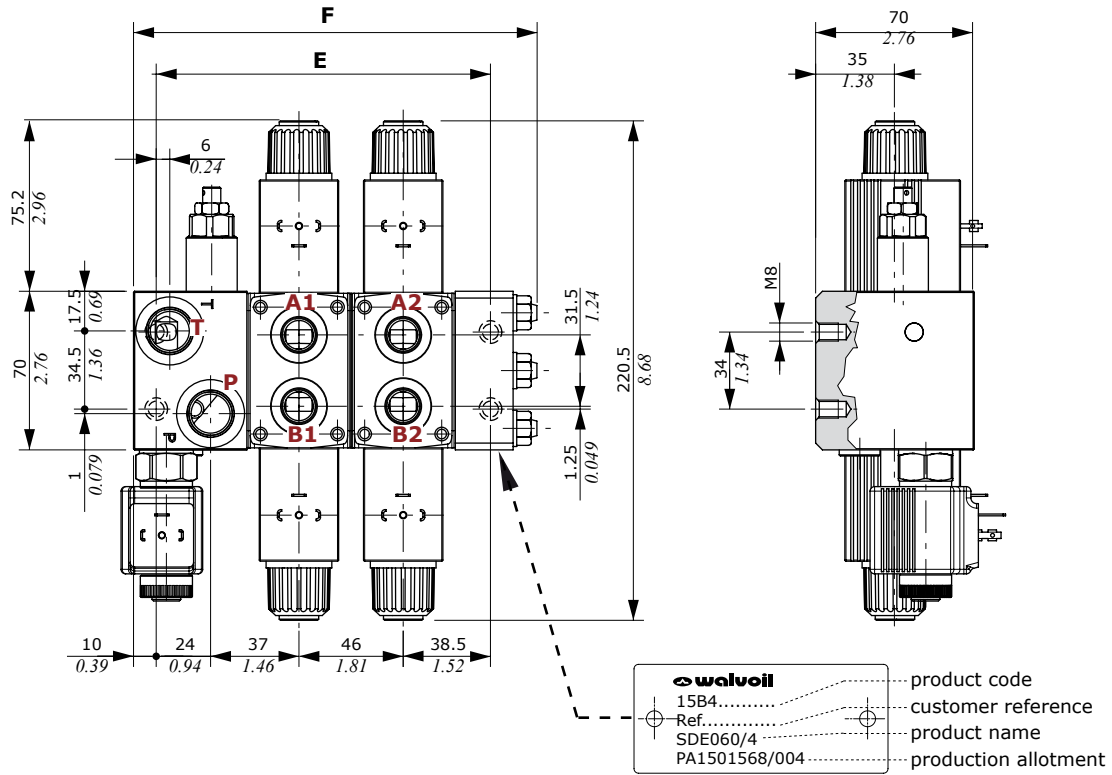

TYPE	ANB type inlet section				AN1B type inlet section (see drawing)				Weight	
	E		F		E		F		Kg	lb
	mm	in	mm	in	mm	in	mm	in		
SDE060/1	83.5	3.26	116.5	4.59	103.5	4.07	136.5	5.37	4.58	10.10
SDE060/2	129.5	5.10	162.5	6.40	149.5	5.89	182.5	7.19	6.61	14.57
SDE060/3	175.5	6.91	208.5	8.21	195.5	7.70	228.5	9.00	8.64	19.05
SDE060/4	221.5	8.72	254.5	10.02	241.5	9.51	274.5	10.81	10.67	23.52
SDE060/5	267.5	10.53	300.5	11.83	287.5	11.32	320.5	12.62	12.70	28.00
SDE060/6	313.5	12.34	346.5	13.64	333.5	13.13	366.5	14.43	14.73	32.47
SDE060/7	359.5	14.15	392.5	15.45	379.5	14.94	412.5	16.24	16.76	36.95
SDE060/8	405.5	15.96	438.5	17.26	425.5	16.75	458.5	18.05	18.79	41.42
SDE060/9	451.5	17.78	484.5	19.07	471.5	18.56	504.5	19.86	20.82	45.90
SDE060/10	497.5	19.59	530.5	20.89	517.5	20.37	550.5	21.67	22.85	50.38

TYPE	AN2B type inlet section				AN6B-AN7B type inlet sections			
	E		F		E		F	
	mm	in	mm	in	mm	in	mm	in
SDE060/1	128	5.04	161	6.34	120.5	4.74	153.5	6.04
SDE060/2	174	6.85	207	8.15	166.5	6.56	199.5	7.85
SDE060/3	220	8.66	253	9.96	212.5	8.37	245.5	9.67
SDE060/4	266	10.47	299	11.77	258.5	10.18	291.5	11.48
SDE060/5	312	12.28	345	13.58	304.5	11.99	337.5	13.29
SDE060/6	358	14.09	391	15.39	350.5	13.80	383.5	15.10
SDE060/7	404	15.91	437	17.20	396.5	15.61	429.5	16.91
SDE060/8	450	17.72	483	19.02	442.5	17.42	475.5	18.72
SDE060/9	496	19.53	529	20.83	488.5	19.23	521.5	20.53
SDE060/10	542	21.34	575	22.64	534.5	21.04	567.5	22.34

**Parallel circuit**

A parallel circuit can be composed using P or Q working sections.  
The outlet section can be with or without port arrangement.

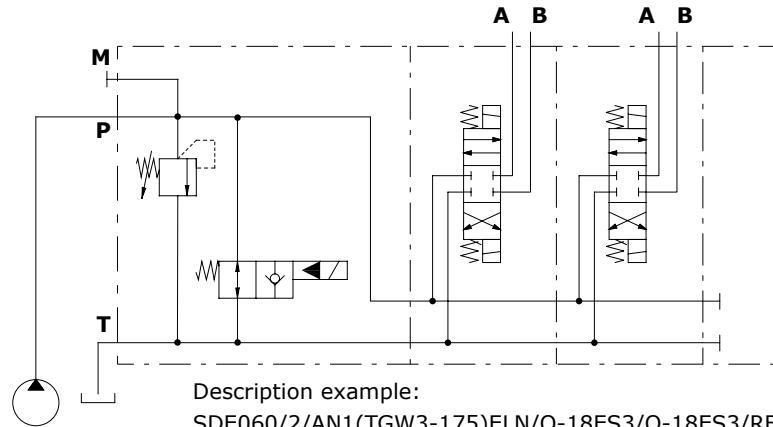

Description example:  
SDE060/2/AN1(TGW3-175)ELN/Q-18ES3/Q-18ES3/RF-12VDC

**Series circuit: only for 60 l/min (15.8 US gpm) sections**

The series circuit is composed using alternately QS and Q working sections, both with 1S series spool.  
The circuit starts always with QS working section.  
The outlet section depends on total number of working sections: if it is even, the outlet section must have P port open, if it is odd, the outlet section must have T port open.

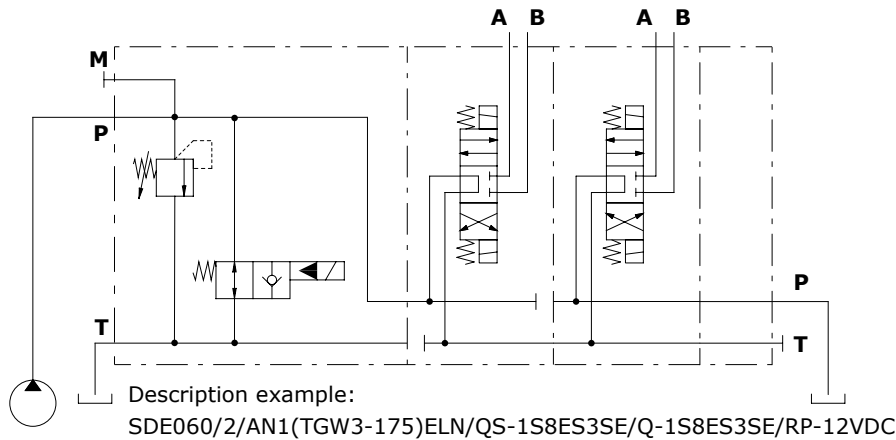

Description example:  
SDE060/2/AN1(TGW3-175)ELN/QS-1S8ES3SE/Q-1S8ES3SE/RP-12VDC

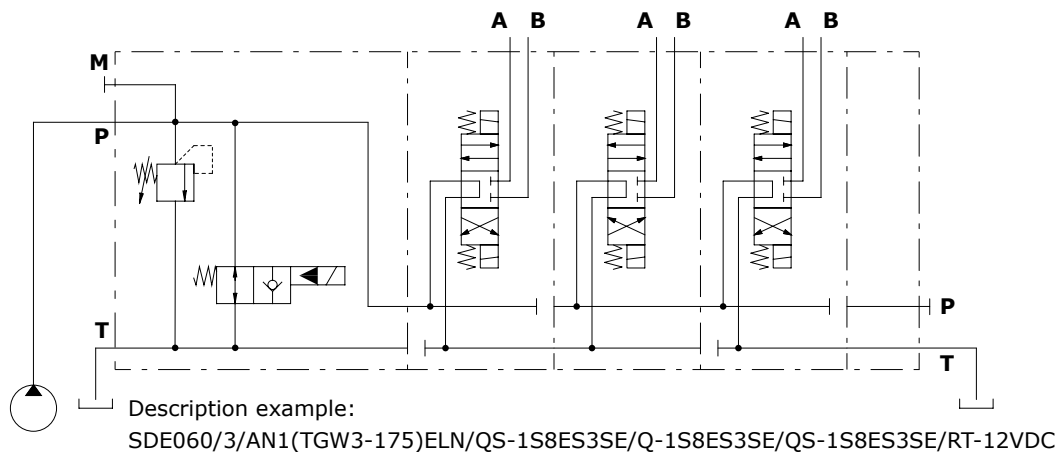

Description example:  
SDE060/3/AN1(TGW3-175)ELN/QS-1S8ES3SE/Q-1S8ES3SE/QS-1S8ES3SE/RT-12VDC

## Complete section ordering codes

**SDE060/4/AN1(TGW3-120)ELN/Q-18ES3/Q-18ES3.BPEN3/Q-18ES3B/**

Nr. of working sections    **1**                      **2**                      **2**                      **4**                      **2**

**Q-18ES3B.PS3(DC3-100)/RF-.....-12VDC**

**2**                      **4**                      **3**                      **5**                      **6**

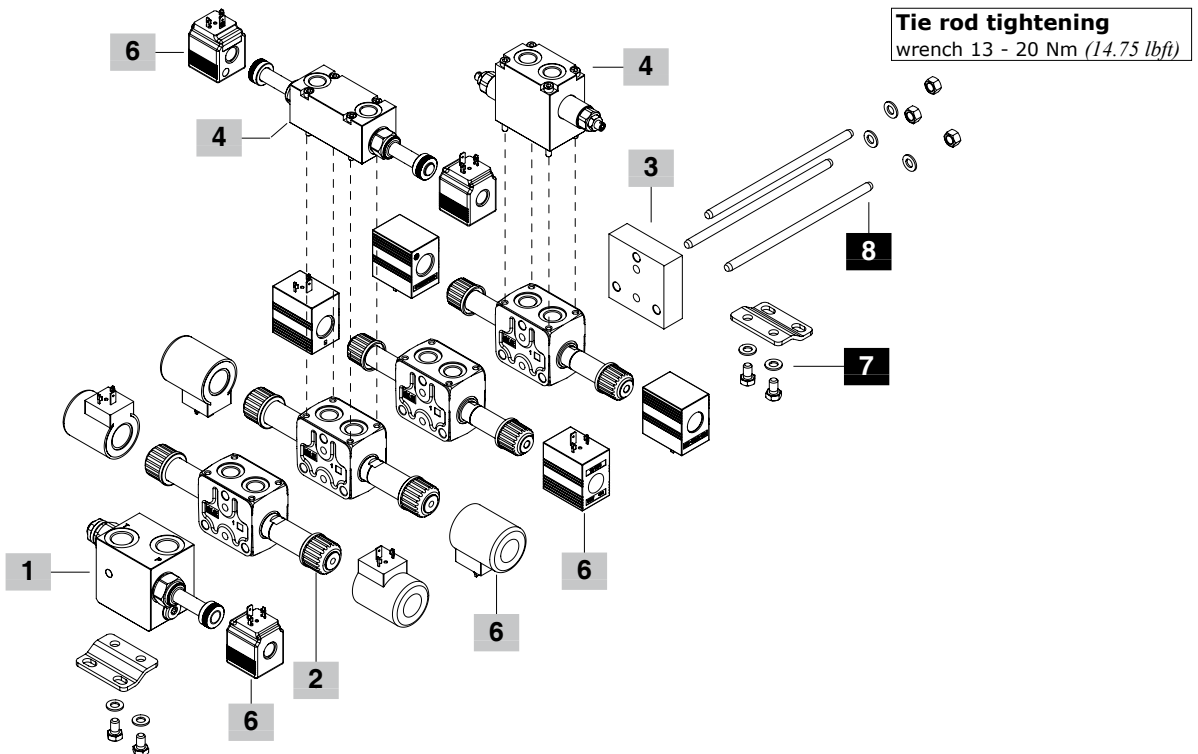

**SDE060/2/AN1B(JNG3-120)ELN/Q-18ES3B/Q-18ES3B.PS3(DC3-100)/RF-.....-12VDC**

Nr. of working sections    **1**                      **2**                      **2**                      **4**                      **3**                      **5**                      **6**

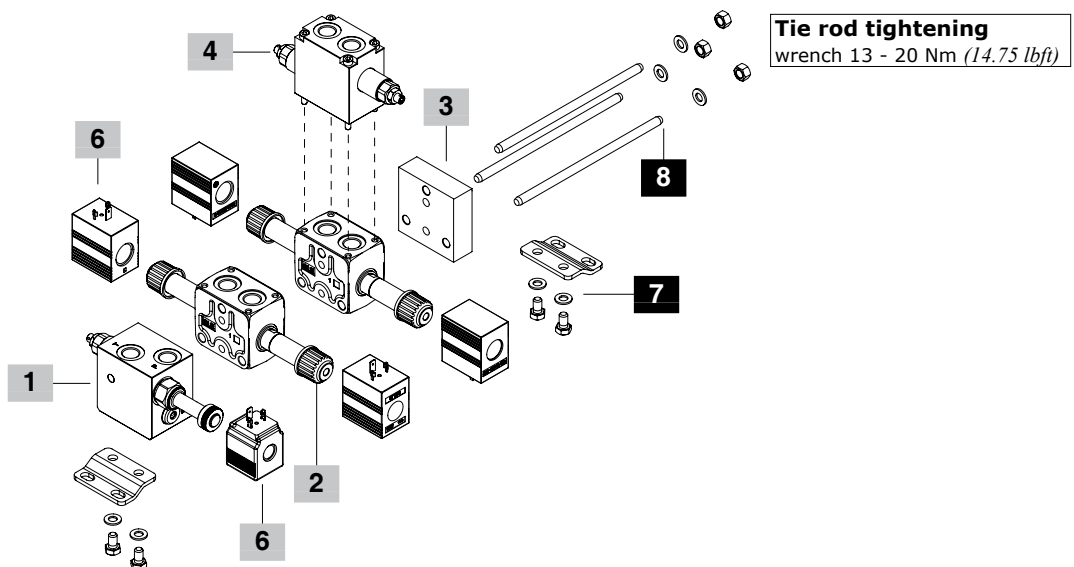

Complete section ordering codes

**1 Complete inlet section \* page 32**

Section bodies are steel made

TYPE: **AN-SAE** CODE: 5FIA103706  
 DESCRIPTION: Without valves arrangement, SAE8 ports, P and T open  
 TYPE: **ANP-SAE** CODE: 5FIA103702  
 DESCRIPTION: As type AN, port P open and T plugged  
 TYPE: **ANT-SAE** CODE: 5FIA103702  
 DESCRIPTION: As type AN, port P plugged and T open  
 TYPE: **ANS-SAE** CODE: 5FIA103705  
 DESCRIPTION: As type AN, ports P and T plugged  
 TYPE: **AN1(TGW3-175)ELN-WC-SAE** CODE: Y61S607000  
 DESCRIPTION: With pressure relief valve and solenoid operated unloading valve, SAE8 ports, P and T open  
 TYPE: **AN1B(JNG3-120)ELN-WC-SAE** CODE: Y61S307000  
 DESCRIPTION: As previous one, up to 30 l/min (7.9 US gpm)  
 TYPE: **AN1P(TGW3-175)ELN-WC-SAE** CODE: Y61S607003  
 DESCRIPTION: As type AN1 port P open and T plugged  
 TYPE: **AN1PB(JNG3-120)ELN-WC-SAE** CODE: Y61S307002  
 DESCRIPTION: As previous one, up to 30 l/min (7.9 US gpm)  
 TYPE: **AN2/PPXN1(TGW3-175)ELN-WC-SAE** CODE: Y61S607001  
 DESCRIPTION: With pressure relief valve, solenoid operated unloading valve and pressure compensated flow control valve, SAE8 ports, P and T open  
 TYPE: **AN2B/PPXN1(JNG3-120)ELN-WC-SAE** CODE: Y61S307001  
 DESCRIPTION: As previous, up to 30 l/min (7.9 US gpm)  
 TYPE: **AN2P/PPXN1(TGW3-175)ELN-WC-SAE** CODE: Y61S607006  
 DESCRIPTION: As type AN2, port P open and T plugged  
 TYPE: **AN2PB/PPXN1(JNG3-120)ELN-WC-SAE** CODE: Y61S307005  
 DESCRIPTION: As previous one, up to 30 l/min (7.9 US gpm)  
 TYPE: **AN6/EEXL1(VMP02TR-220)-SB7RC(C5)-WC-SAE** CODE: Y61S607010  
 DESCRIPTION: With pressure relief valve and flow control valve, for Open Center circuit, compensator with 7 bar (100 psi) stand-by, SAE8 ports, P and T open  
 TYPE: **AN6B/EEXL1(VMP02TR-220)-SB10RC(C3)-WC-SAE** CODE: Y61S307006  
 DESCRIPTION: With pressure relief valve and flow control valve, for Open Center circuit, compensator with 10 bar (145 psi) stand-by, SAE8 ports, P and T open, up to 30 l/min (7.9 US gpm)  
 TYPE: **AN7/EEEXN1(VMP02TR-200)-SB7RCV(C5)-WC-SAE** CODE: Y61S607011  
 DESCRIPTION: As AN6, compensator with handwheel actuation for Open to Closed Center switching, SAE8 ports P and T open.  
 TYPE: **AN7B/EEEXN1(VMP02TR-200)-SB10RCV(C3)-WC-SAE** CODE: Y61S307007  
 DESCRIPTION: As AN6B, compensator with handwheel actuation for Open to Closed Center switching, SAE8 ports P and T open, up to 30 l/min (7.9 US gpm)  
 TYPE: **AN11-EEEXN1(VMP02TR-200)-CL-WC-SAE** CODE: Y61S607008  
 DESCRIPTION: As AN6, for Closed Center circuit, compensator blanking plug, G3/8 ports P and T open  
 TYPE: **AN11B-EEEXN1(VMP02TR-200)-CL-WC-SAE** CODE: Y61S307008  
 DESCRIPTION: As AN6B, for Closed Center circuit, compensator blanking plug, G3/8 ports P and T open, up to 30 l/min (7.9 US gpm)

NOTE (\*) – Codes are referred to **UN-UNF** thread.

**2 Complete working section \* page 46**

Section bodies are cast iron made

Sections are arranged for flangeable valve blocks

TYPE	CODE	DESCRIPTION
<b>Q-18ES3-WC-SAE</b>	Y63S607001C	Parallel circuit, SAE6 ports, type 1 double acting spool
<b>Q-18ES3B-WC-SAE</b>	Y63S307001C	As previous, one up to 30 l/min (7.9 US gpm)
<b>Q-28ES3-WC-SAE</b>	Y63S607002C	Parallel circuit, SAE6 ports, type 2 double acting spool
<b>Q-28ES3B-WC-SAE</b>	Y63S307002C	As previous, one up to 30 l/min (7.9 US gpm)
<b>QS-1S8ES3SE-WC-SAE</b>	Y63S607003C	Series circuit, SAE6 ports, type 1S double acting series spool
<b>Q-1S8ES3SE-WC-SAE</b>	Y63S607005C	Parallel circuit, SAE6 ports, type 1S double acting series spool: <b>placed after QS series section only</b>

**3 Complete outlet section\* page 57**

Unless otherwise stated, outlet section bodies are steel made.

TYPE	CODE	DESCRIPTION
<b>RF</b>	3FIA203000	Without ports, aluminium alloy body
<b>RS-SAE</b>	619305200	With SAE 8 ports, P and T plugged
<b>RP-SAE</b>	619305100	As previous one, P open and T plugged
<b>RT-SAE</b>	619305000	As previous one, T open and P plugged

**4 Complete flangeable valve block**

**Antishock valves . . . . .page 52**  
**Check valves . . . . .page 53**  
**Solenoid operated check valves (without coils) . . . .page 54**  
**Single counterbalance valves . . . . .page 55**  
**Double counterbalance valves. . . . .page 56**

**5 Valve threading**

Specify threading always when it is different from BSP standard (see page 4).

**6 Coils page 58**

Coils voltage specification; for list of available coils see pages of related sections

**7 Fixing bracket page 61**

TYPE	CODE	DESCRIPTION
<b>STAF</b>	5STA148065	Brackets with fixing screws

**8 Assembling kit**

CODE	DESCRIPTION	CODE	DESCRIPTION
5TIR108099	For 1 section valve	5TIR108329	For 6 sections valve
5TIR108144	For 2 sections valve	5TIR108375	For 7 sections valve
5TIR108191	For 3 sections valve	5TIR108420	For 8 sections valve
5TIR108236	For 4 sections valve	5TIR108466	For 9 sections valve
5TIR108282	For 5 sections valve	5TIR108512	For 10 sections valve

## Inlet section: part ordering codes

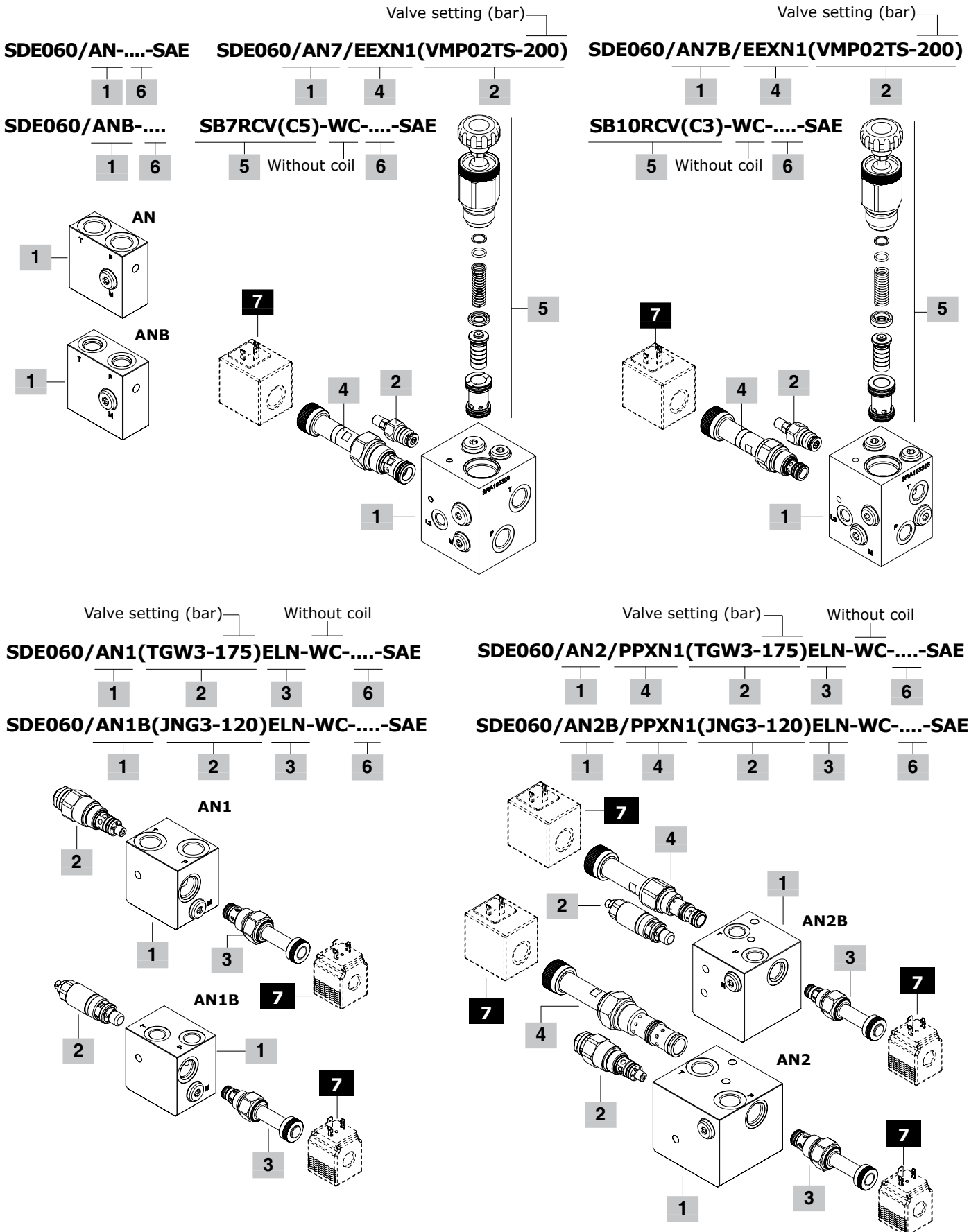



## Inlet section: part ordering codes

**1 Inlet section body kit \* page 34**

Section bodies are steel made

TYPE	CODE	DESCRIPTION
<b>AN-SAE</b>	5FIA103706	Without valves arrangement, SAE8 ports, P and T open
<b>ANP-SAE</b>	5FIA103702	As AN, port P open and T plugged
<b>ANT-SAE</b>	5FIA103702	As AN, port P plugged and T open
<b>ANS-SAE</b>	5FIA103705	As AN, ports P and T plugged
<b>AN1-SAE</b>	5FIA103703	Relief and unloader valves arrangement, SAE8 ports, P and T open
<b>AN1P-SAE</b>	5FIA103709	As previous one, port P open and T plugged
<b>AN1B-SAE</b>	5FIA103700	As AN1, up to 30 l/min (7.9 US gpm)
<b>AN1PB-SAE</b>	5FIA103707	As AN1P, up to 30 l/min (7.9 US gpm)
<b>AN2-SAE</b>	5FIA103704	Relief, unloader and flow control valves arrangement, SAE8 ports, P and T open
<b>AN2P-SAE</b>	5FIA103710	As previous one, port P open and T plugged
<b>AN2B-SAE</b>	5FIA103701	As AN2, up to 30 l/min (7.9 US gpm)
<b>AN2PB-SAE</b>	5FIA103708	As AN2P, up to 30 l/min (7.9 US gpm)
<b>AN6-SAE</b>	5FIA103720	For Open Center, relief and flow control valves arrangement, compensator, LS port plugged, SAE8 ports, P and T open
<b>AN6B-SAE</b>	5FIA103716	For Open Center, relief and flow control valves arrangement, compensator, LS port plugged, SAE8 ports, P and T open, up to 30 l/min (7.9 US gpm)
<b>AN7/AN11-SAE</b>	5FIA103720A	As AN6, for Closed Center, with LS port open
<b>AN7B/AN11B-SAE</b>	5FIA103717	As AN6B, for Closed Center, with LS port open, up to 30 l/min (7.9 US gpm)

**2 Main relief valve page 39**

TYPE	CODE	DESCRIPTION
<b>For sections AN1-AN2 type</b>		
Valve standard setting is referred to 5 l/min (1.3 US gpm) flow.		
<b>(TGW2-80)</b>	OMC10002023	Range 10-120 bar (145-1750 psi) std setting 80 bar (1160 psi)
<b>(TGW3-175)</b>	OMC10002024	Range 40-200 bar (580-2900 psi) std setting 175 bar (2550 psi)
<b>(TGW4-250)</b>	OMC10002025	Range 200-350 bar (2900-5100 psi) std setting 250 bar (3600 psi)
<b>SV</b>	XTAP526360	Relief valve blanking plug
<b>For sections AN1B-AN2B type</b>		
Valve standard setting is referred to 10 l/min (2.6 US gpm) flow, considering the valve mounted on inlet section.		
<b>(JNG2-63)</b>	5KIT105512	Range 40-63 bar (580-900 psi) std setting 63 bar (900 psi)
<b>(JNG3-120)</b>	5KIT105513	Range 50-200 bar (725-2900 psi) std setting 120 bar (1750 psi)
<b>(JNG4-220)</b>	5KIT105514	Range 160-315 bar (2300-4600 psi) std setting 220 bar (3200 psi)
<b>(JNH2-63)</b>	5KIT105517	As type JNG2, set and locked
<b>(JNH3-120)</b>	5KIT105516	As type JNG3, set and locked
<b>(JNH4-220)</b>	5KIT105515	As type JNG4, set and locked
<b>(JNZT2-63)</b>	5KIT105562	As type JNG2, anti-tampering type
<b>(JNZT3-120)</b>	5KIT105563	As type JNG3, anti-tampering type
<b>(JNZT4-220)</b>	5KIT105564	As type JNG4, anti-tampering type
<b>SV</b>	XTAP623282	Relief valve blanking plug
<b>For sections AN6-AN7-AN6B-AN7B-AN11-AN11B type</b>		
Valve standard setting is referred to 1 l/min (0.26 US gpm) flow, considering the valve mounted on inlet section.		
<b>(VMP02TV-50)</b>	1100000100	Range 5-80 bar (73-1160 psi) std setting 50 bar (725 psi)
<b>(VMP02TS-150)</b>	1100000101	Range 50-220 bar (725-3200 psi) std setting 150 bar (2200 psi)
<b>(VMP02TR-250)</b>	1100000102	Range 180-350 bar (2600-5100 psi) std setting 250 bar (3600 psi)

**3 Solenoid operated unloading valve page 41**

TYPE	CODE	DESCRIPTION
<b>For sections AN1-AN2 type</b>		
<b>ELN</b>	0EC10002012	Without emergency override
<b>ELV</b>	0EC10002015	With screw type emergency override
<b>ELP</b>	0EC10002014	With push-button emergency override
<b>ELT</b>	0EC10002016	With "twist & push" emergency override
<b>LT</b>	3XTP3544200	Unloading valve blanking plug
<b>For sections AN1B-AN2B type</b>		
<b>ELN</b>	0EC08002031	Without emergency actuation
<b>ELV</b>	0EC08002034	With screw type emergency actuation
<b>ELP</b>	0EC08002033	With push-button emergency actuation
<b>ELT</b>	0EC08002035	With "twist & push" emergency actuation
<b>LT</b>	XTAP510320	Unloading valve blanking plug

**4 Flow control valve page 42**

TYPE	CODE	DESCRIPTION
<b>For sections AN1-AN2 type</b>		
<b>PPAL1</b>	OPP12002000	Hand-wheel setting type
<b>PPAV1</b>	OPP12002004	Screw setting type
<b>PPXN1</b>	OPP12002037	Solenoid operated, without emergency
<b>PPXV1</b>	OPP12002039	Solenoid operated, screw emergency
<b>PPXL1</b>	OPP12002041	Solenoid operated, hand-wheel emergency
<b>LT</b>	3XTP3558200	Flow control valve blanking plug
<b>For sections AN1B-AN2B type</b>		
<b>PPAL1</b>	OPP10002000	Hand-wheel setting type
<b>PPAV1</b>	OPP10002005	Screw setting type
<b>PPXN1</b>	OPP10002031	Solenoid operated, without emergency
<b>PPXV1</b>	OPP10002033	Solenoid operated, screw emergency
<b>PPXL1</b>	OPP10002035	Solenoid operated, hand-wheel emergency
<b>LT</b>	3XTP3545700	Flow control valve blanking plug
<b>For sections AN6-AN7-AN11 type</b>		
<b>EEXN1</b>	0EE12002007	Solenoid operated, without emergency
<b>EEXL1</b>	0EE12002009	Solenoid operated, hand-wheel emergency
<b>For sections AN6B-AN7B-AN11B type</b>		
<b>EEXN1</b>	0EE10002009	Solenoid operated, without emergency
<b>EEXL1</b>	0EE10002008	Solenoid operated, hand-wheel emergency

**5 Compensator kit page 44**

TYPE	CODE	DESCRIPTION
<b>For section type AN6</b>		
<b>SB7RC(C5)</b>	5KT6200230	With 7 bar (100 psi) stand-by, for Open Center circuit
<b>For section type AN7</b>		
<b>SB7RCV(C5)</b>	5KT6200231	With 7 bar (100 psi) stand-by, hand-wheel actuation for Open Center to Closed Center switching
<b>For section type AN6B</b>		
<b>SB10RC(C3)</b>	5KT6200222	With 10 bar (145 psi) stand-by, for Open Center circuit
<b>For section type AN7B</b>		
<b>SB10RCV(C3)</b>	5KT6200227	With 10 bar (145 psi) stand-by, hand-wheel actuation for Open Center to Closed Center switching
<b>For section type AN11-AN11B</b>		
<b>CL</b>	X451810000	Compensator blanking plug, for Closed Center circuit

**6 Section threading**

Specify threading always when it is different from BSP standard (see page 4).

**7 Optional coil page 58**

For list of available coils see pages of related section.

NOTE (\*) - Codes are referred to **UN-UNF** thread.

Inlet section: dimension and hydraulic circuit

AN inlet section

AN type  
with P and T ports open

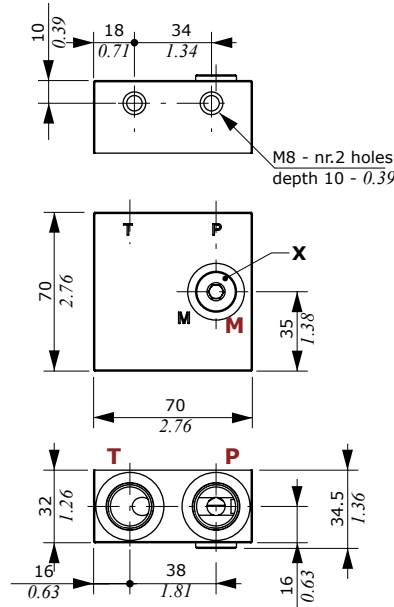

Wrenches and tightening torque

X = allen wrench 6 - 24 Nm (17.7 lbf)

AN-ANB type

P and T ports open

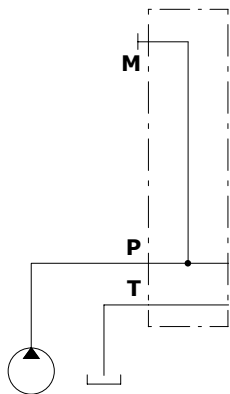

ANP-ANPB type

P port open and T port plugged

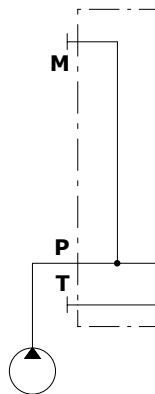

ANT-ANTB type

P port plugged and T port open

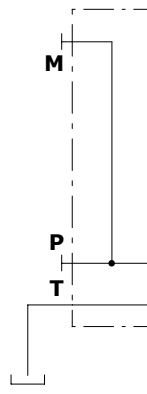

ANS-ANSB type

P and T ports plugged

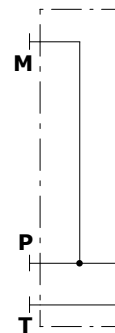

Inlet section: dimension and hydraulic circuit

AN1-AN1B inlet sections

AN1 type with P and T ports open

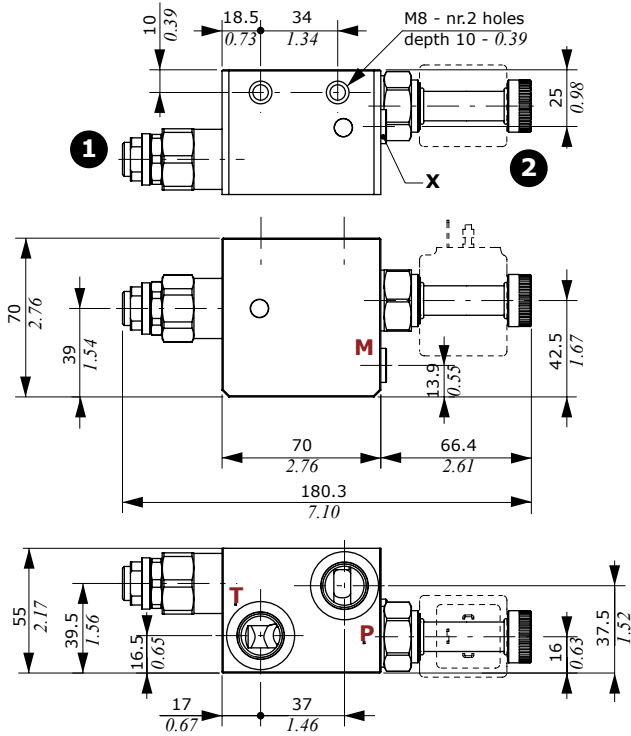

AN1B type with P and T ports open

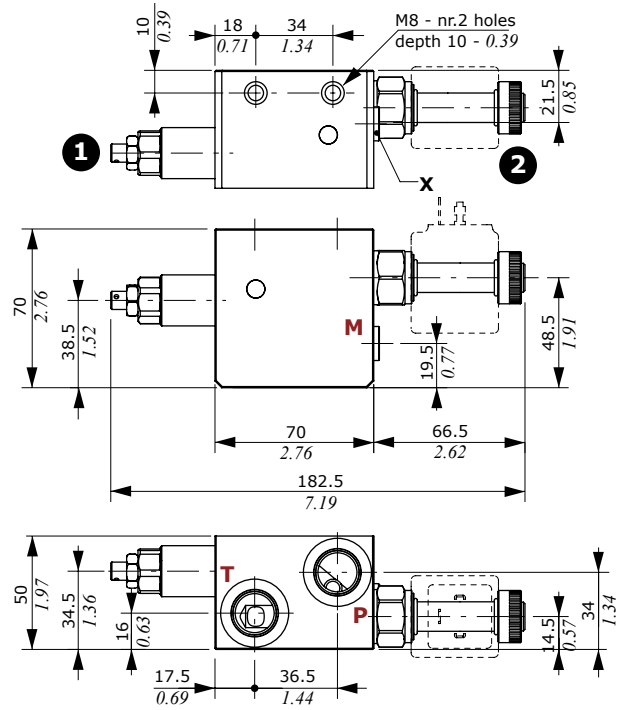

Legenda

- 1: Pressure relief valve
- 2: Solenoid operated unloading valve

Wrenches and tightening torque

X = allen wrench 5 - 9.8 Nm (7.2 lbf)  
 NOTE: for valve wrench and torque see pages 39 and 41.

AN1-AN1B types  
 P and T ports open

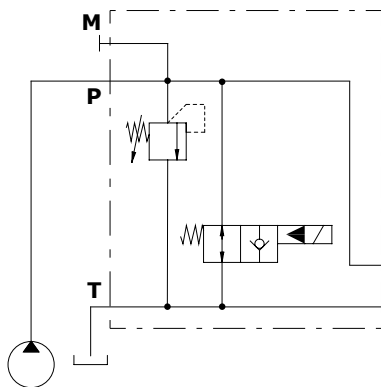

AN1P-AN1PB types

P port open and T port plugged

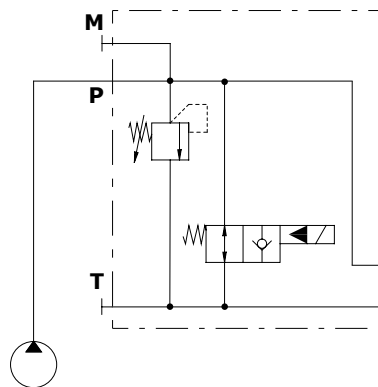

Inlet section: dimension and hydraulic circuit

AN2-AN2B inlet sections

AN2 type with P and T ports open

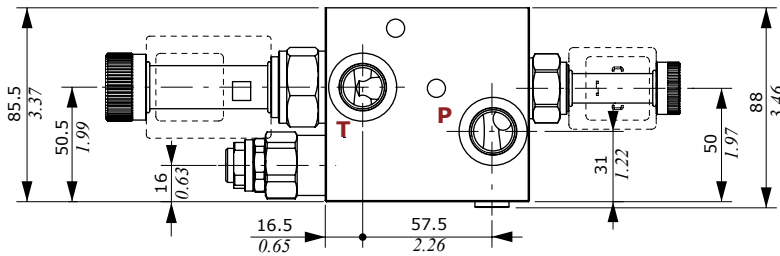
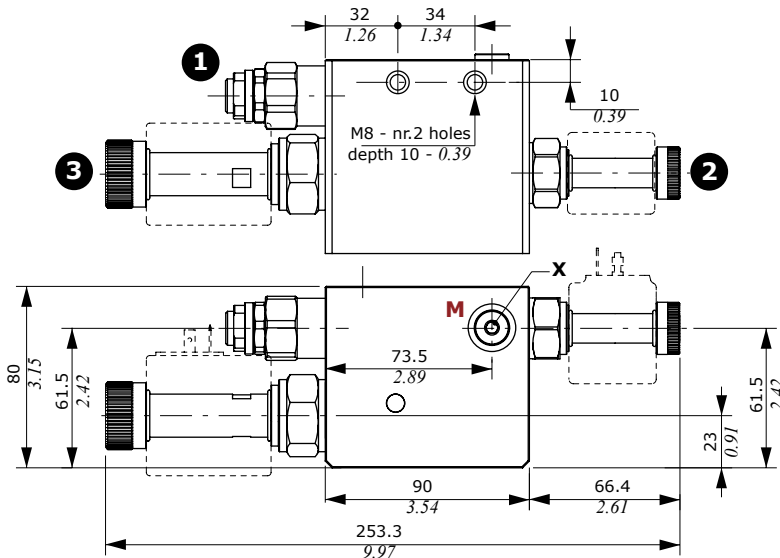

AN2B type with P and T ports open

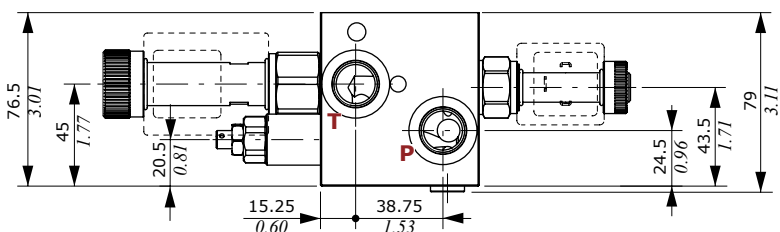
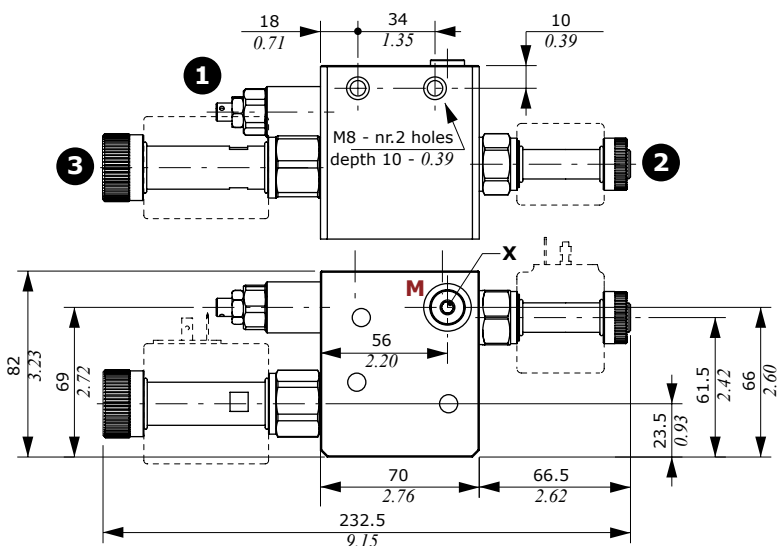

Legenda

- 1: Pressure relief valve
- 2: Solenoid operated unloading valve
- 3: Pressure compensated flow control valve

Wrenches and tightening torque

X = allen wrench 5 - 9.8 Nm (7.2 lbf)  
NOTE: for valve wrench and torque see pages from 39 to 45.

AN2-AN2B types  
P and T ports open

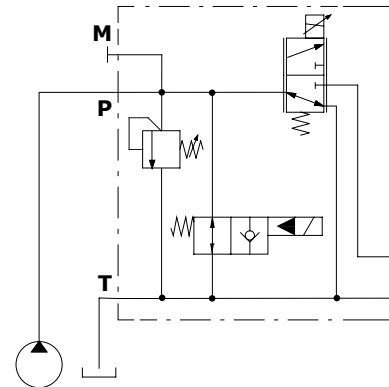

AN2P-AN2PB types  
P port open and T port plugged

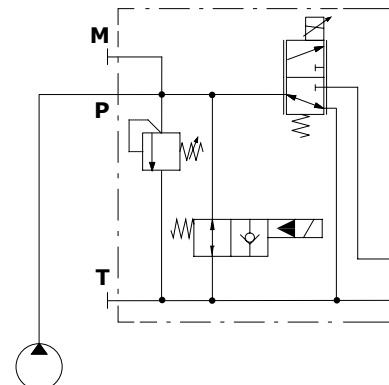

Inlet section: dimension and hydraulic circuit

AN6-AN7-AN11 inlet sections

AN7 type; configuration for Open and Closed Center

Legenda

- 1: Pressure relief valve
- 2: Flow control valve
- 3: Excludable compensator

Wrenches and tightening torque

X = allen wrench 6 - 24 Nm (17.7 lbf<sup>t</sup>)  
 NOTE: for valve wrench and torque see pages 40 and 44.

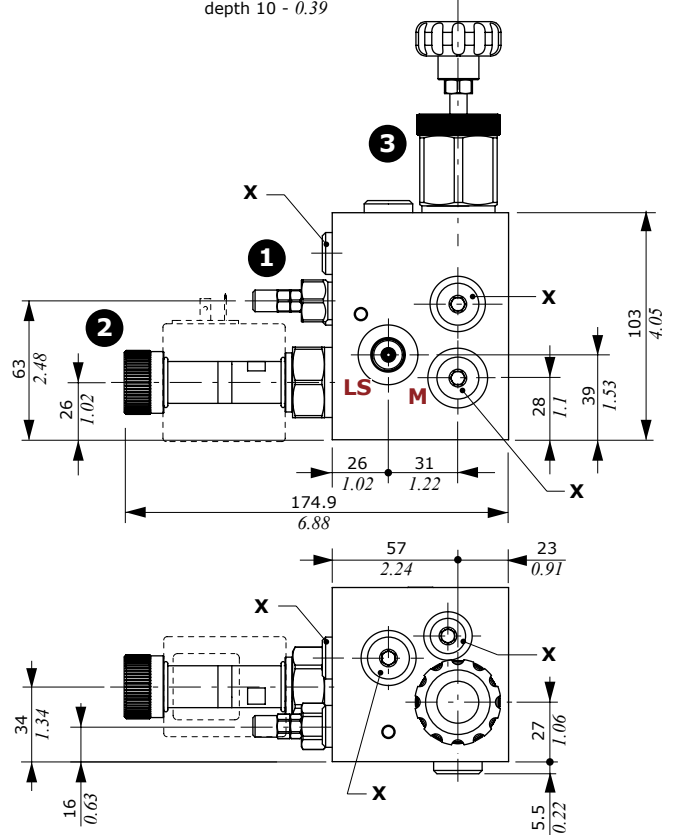
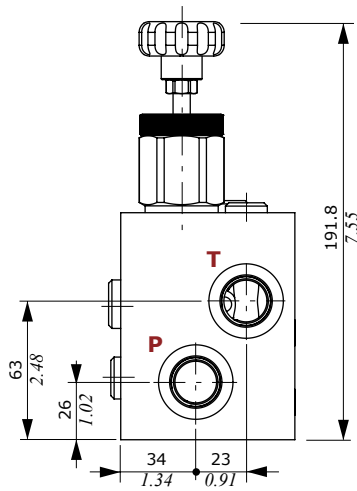
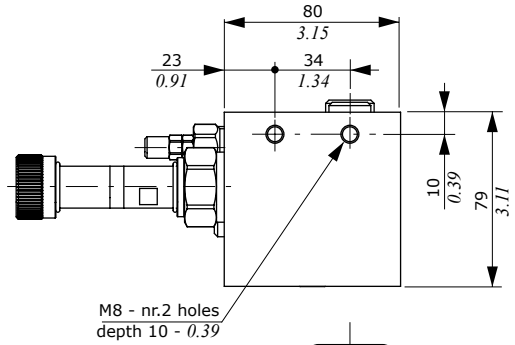

AN6 type  
for Open Center circuit

AN7 type  
for Closed and Open Center circuits

AN11 type  
for Closed Center circuit

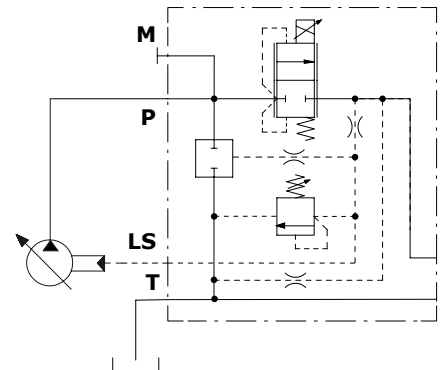
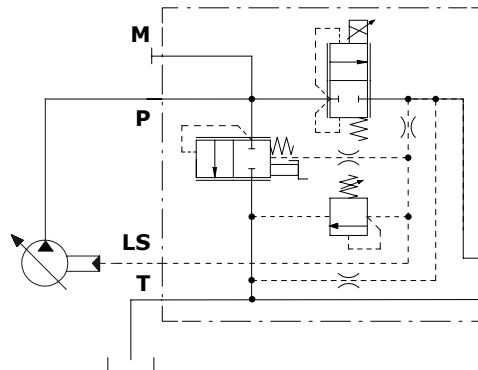
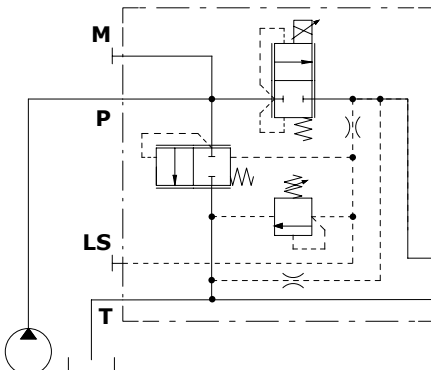

## Inlet section: dimension and hydraulic circuit

### AN6B-AN7B-AN11B inlet sections

#### AN7B type; configuration for Open and Closed Center

#### Legenda

- 1: Pressure relief valve
- 2: Flow control valve
- 3: Excludable compensator

#### Wrenches and tightening torque

X = allen wrench 6 - 24 Nm (17.7 lbf)  
 Y = allen wrench 4 - 9.8 Nm (7.2 lbf)  
 Z = allen wrench 5 - 9.8 Nm (7.2 lbf)  
 NOTE: for valve wrench and torque see pages 40 and 45.

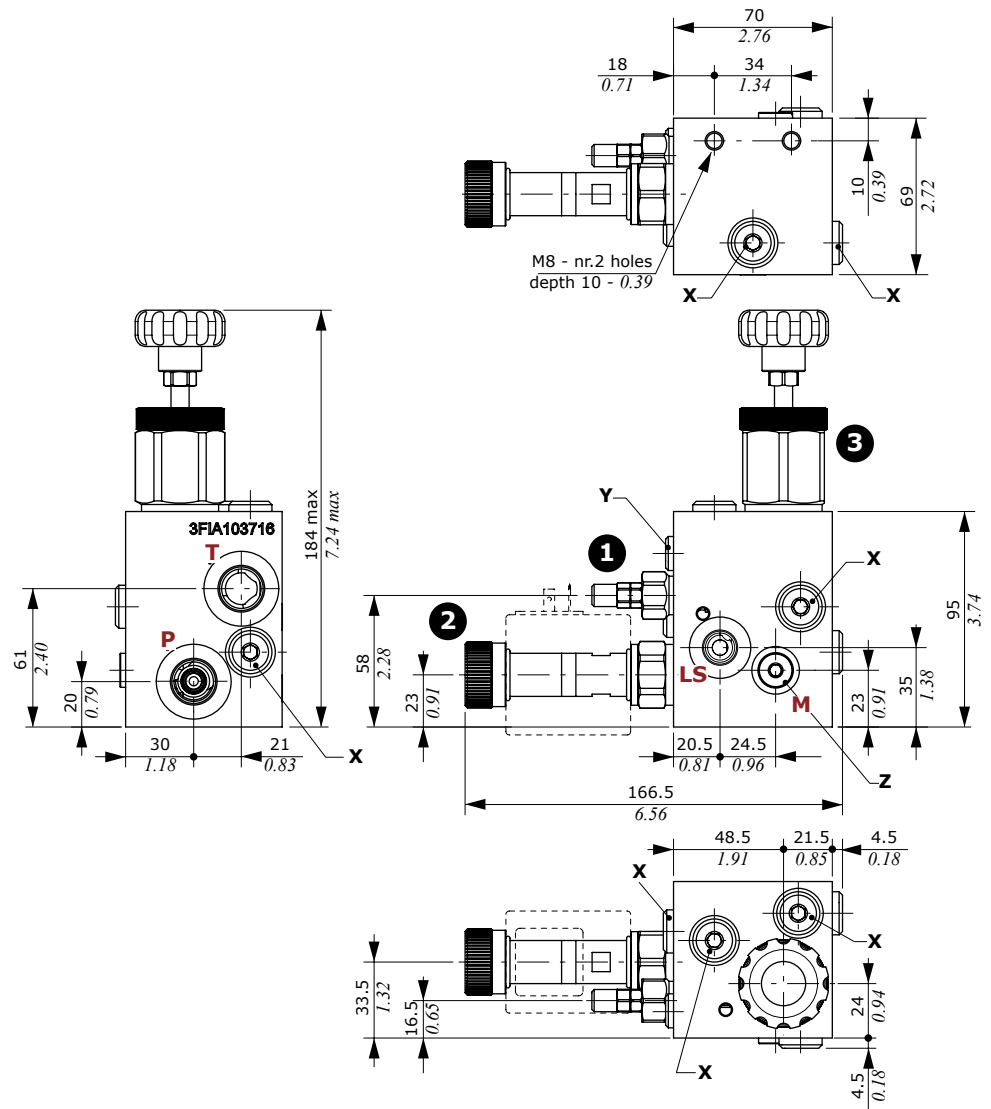

**AN6B type**  
for Open Center circuit

**AN7B type**  
for Closed and Open Center circuits

**AN11B type**  
for Closed Center circuit

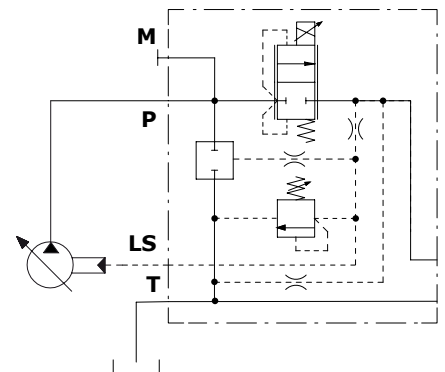
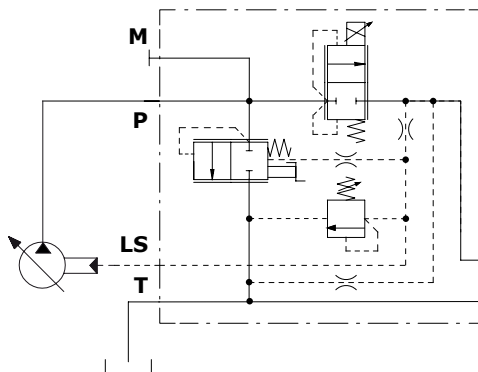
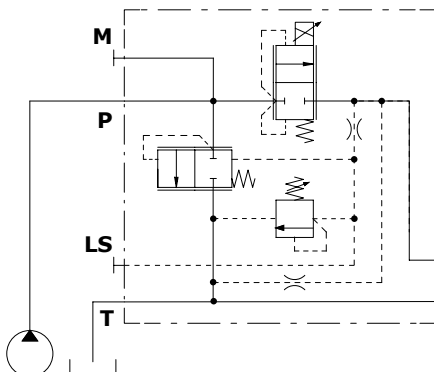

Inlet section: options

Main relief valve

For sections AN1 and AN2 type

Setting types

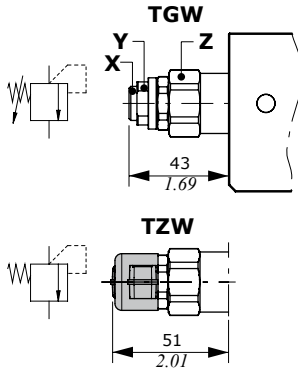

Legenda

**TGW:** screw setting type  
**TZW:** with anti-tampering cap  
 (cap code 4COP126300, nr. 2 pcs)

Wrenches and tightening torque

X = allen wrench 5  
 Y = wrench 19 - 20 Nm (14.8 lbft)  
 Z = wrench 27 - 50 Nm (37 lbft)

Setting range: TGW2 type

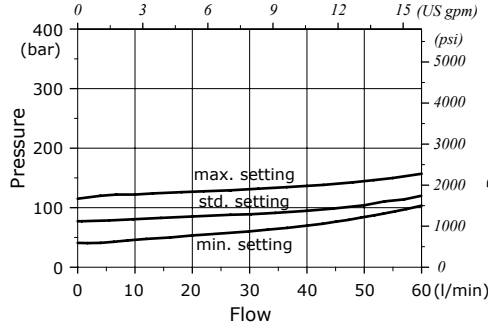

Setting range: TGW3 type

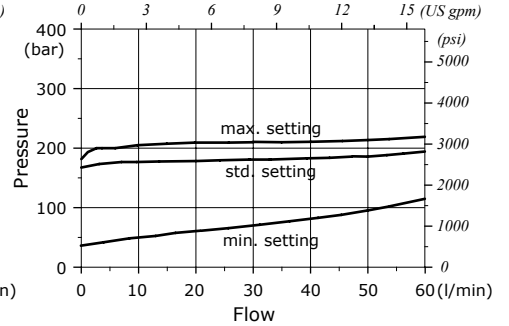

Setting range: TGW4 type

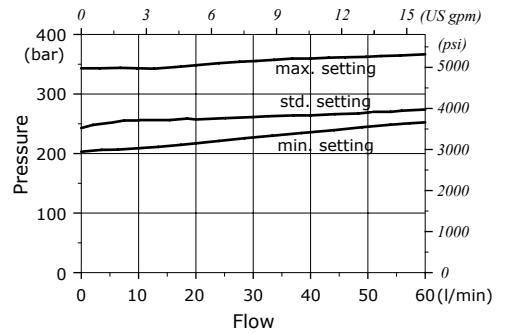

For sections AN1B and AN2B type

Setting types

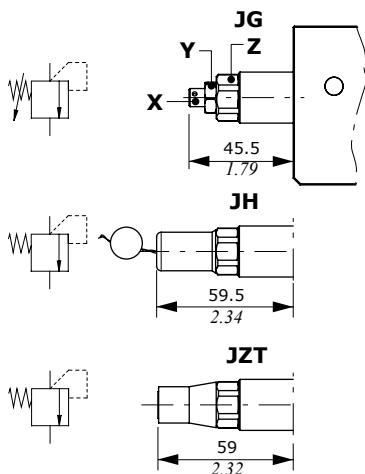

Setting range: JNG2 type

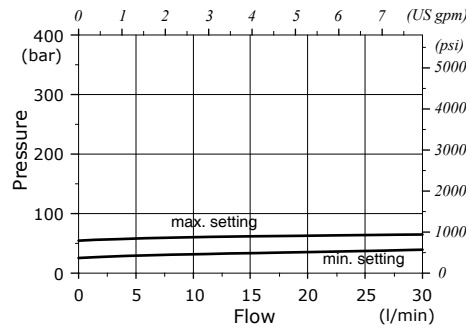

Setting range: JNG3 type

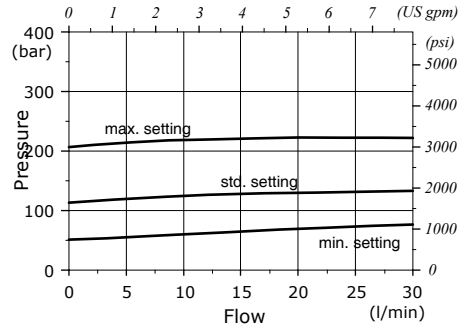

Setting range: JNG4 type

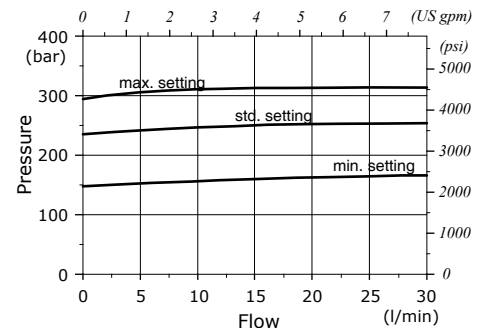

Legenda

**JG:** screw setting type  
**JH:** valve set and locked  
 (cap code 3COP117260)  
**JZT:** valve set and locked  
 (cap code 4COP120420)

Wrenches and tightening torque

X = allen wrench 4  
 Y = wrench 13 - 24 Nm (17.7 lbft)  
 Z = wrench 19 - 24 Nm (17.7 lbft)

Inlet section: options

Main relief valve

For sections AN6 - AN7 - AN11 - AN6B - AN7B and AN11B type

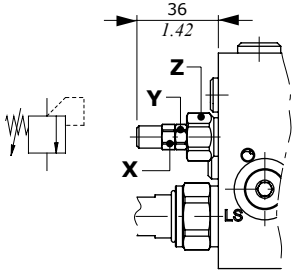

Setting range: VMP02TV type

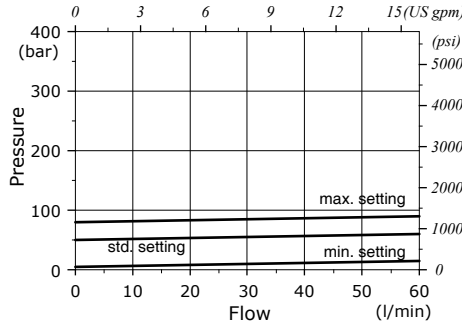

Setting range: VMP02TS type

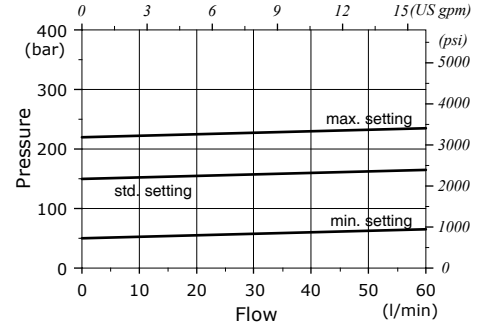

Wrenches and tightening torque

X = wrench 10

Y = wrench 10 - 6.6 Nm (4.9 lbft)

Z = wrench 19 - 24 Nm (17.7 lbft)

Setting range: VMP02TR type

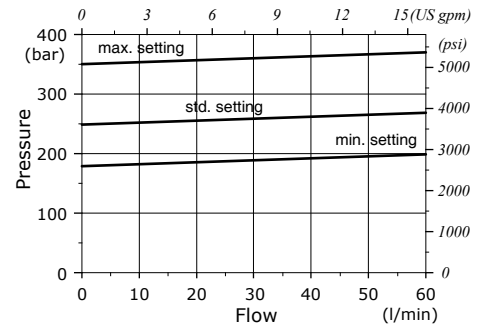



Inlet section: options

Unloading valve

For sections AN1 and AN2 type

Emergency actuation types

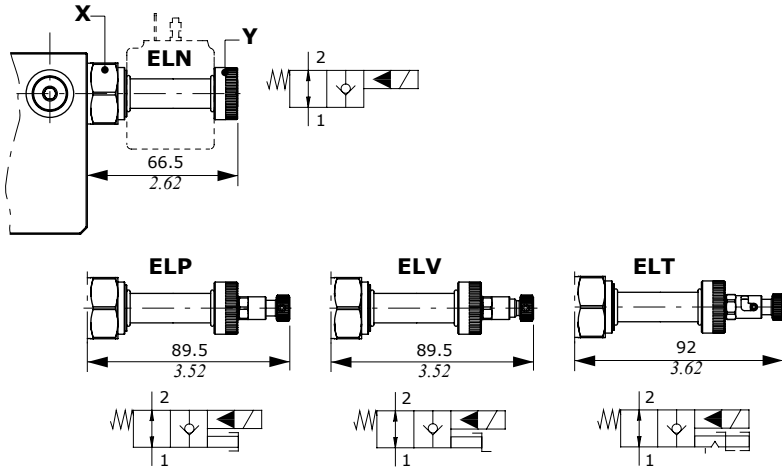

Pressure drop diagram

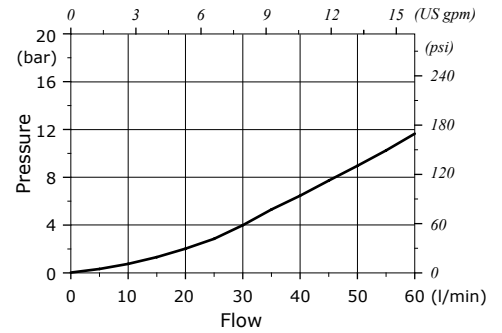

Legenda

- ELN: without emergency actuation
- ELP: push-button type emergency actuation
- ELV: screw type emergency actuation
- ELT: "push&twist" type emergency actuation

Valve features

- Max. flow . . . . . : 60 l/min (15.8 US gpm)
- Max. pressure . . . . . : 380 bar (5500 psi)
- Internal leakage . . . . . : 0.25 cm<sup>3</sup>/min @ 210 bar (0.015 in<sup>3</sup>/min @ 3050 psi)

For coil features and options see **BER** coil on pages 58 and 59

Wrenches and tightening torque

- X = wrench 27 - 50 Nm (37 lbft)
- Y = 5 Nm (3.7 lbft)

For sections AN1B and AN2B type

Emergency actuation types

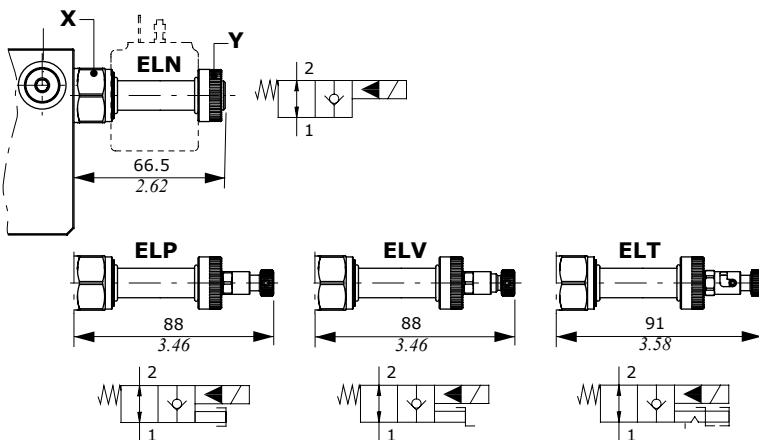

Pressure drop diagram

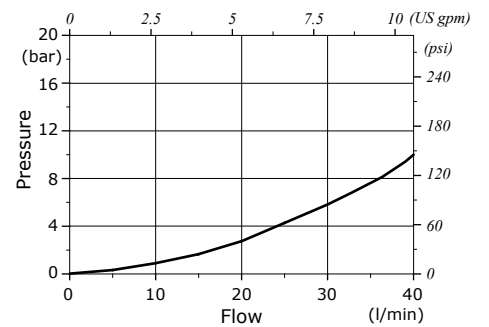

Legenda

- ELN: without emergency actuation
- ELP: push-button type emergency actuation
- ELV: screw type emergency actuation
- ELT: "push&twist" type emergency actuation

Valve features

- Max. flow . . . . . : 40 l/min (10.6 US gpm)
- Max. pressure . . . . . : 380 bar (5500 psi)
- Internal leakage . . . . . : 0.25 cm<sup>3</sup>/min @ 210 bar (0.015 in<sup>3</sup>/min @ 3050 psi)

For coil features and options see **BER** coil on pages 58 and 59

Wrenches and tightening torque

- X = wrench 24 - 30 Nm (22 lbft)
- Y = 5 Nm (3.7 lbft)

Pressure compensated flow control valve

For section AN2 type

Manual operated

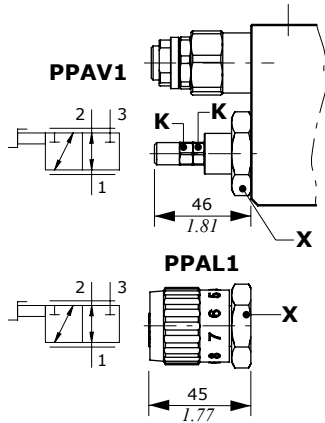

Solenoid operated

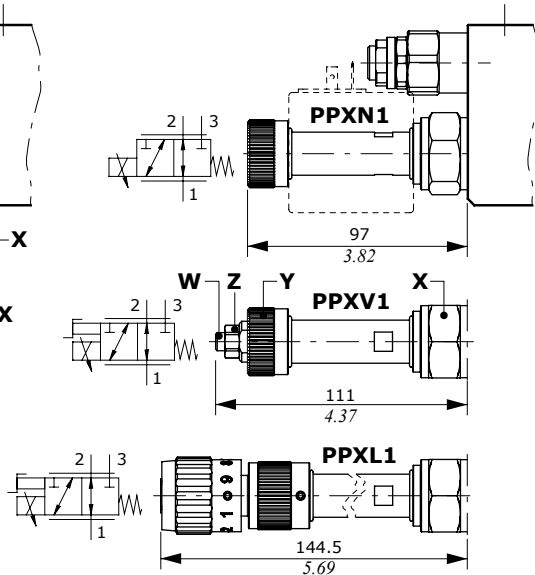

Flow regulation diagram

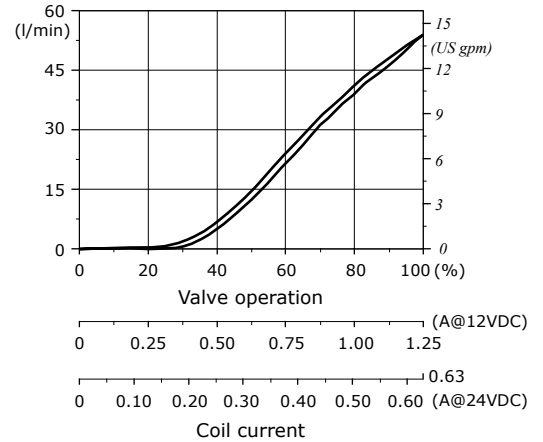

Flow vs. Pressure diagram

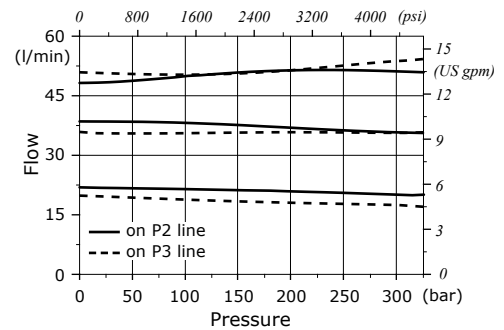

Legenda

- PPAV1: screw setting type
- PPAL1: hand-wheel setting type
- PPXN1: without emergency actuation
- PPXV1: screw type emergency actuation
- PPXL1: hand-wheel emergency actuation

Wrenches and tightening torque

- K = wrench 10 - 6.6 Nm (4.9 lbft)
- X = wrench 32 - 80 Nm (59 lbft)
- Y = 5 Nm (3.7 lbft)
- W = allen wrench 4
- Z = wrench 8 - 15 Nm (11 lbft)

Valve features

- Max. inlet flow . . . . . : 90 l/min (23.8 US gpm)
- Max. regulated flow . . . . . : 50 l/min (13.2 US gpm) - PPA types  
60 l/min (16 US gpm) - PPX types
- Inlet flow (PPX types) . . . . . : regulated flow +15%
- Max. pressure . . . . . : 350 bar (5100 psi) - PPA types  
315 bar (4600 psi) - PPX types
- Internal leakage (PPX types) . . : 250 cm<sup>3</sup>/min a 210 bar  
(15.3 in<sup>3</sup>/min @ 3050 psi)

For coil features and options see **BQP19** or **BH** coils on pages 58 and 59.

Inlet section: options

Pressure compensated flow control valve

For section AN2B type

Manual operated

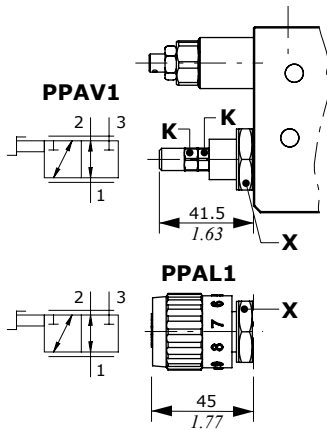

Solenoid operated

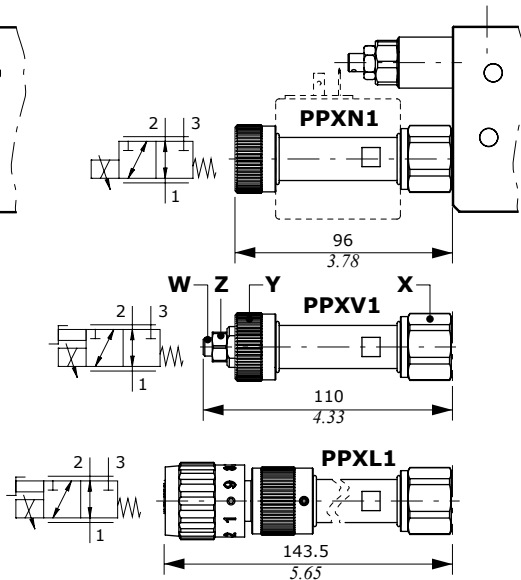

Flow regulation diagram

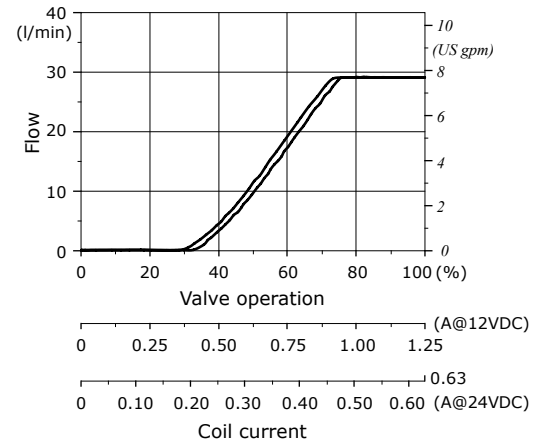

Flow vs. Pressure diagram

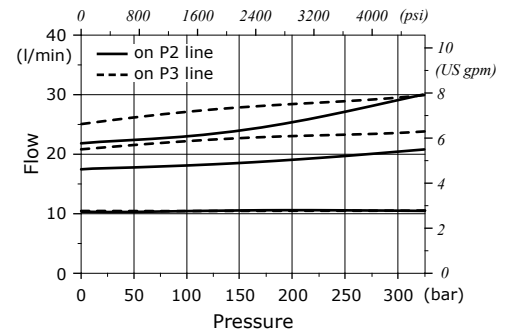

Legenda

- PPAV1: screw setting type
- PPAL1: hand-wheel setting type
- PPXN1: without emergency actuation
- PPXV1: screw type emergency actuation
- PPXL1: hand-wheel emergency actuation

Wrenches and tightening torque

- K = wrench 10 - 6.6 Nm (4.9 lbft)
- X = wrench 27 - 50 Nm (37 lbft)
- Y = 5 Nm (3.7 lbft)
- W = allen wrench 4
- Z = wrench 8 - 15 Nm (11 lbft)

Valve features

- Max. inlet flow . . . . . : 50 l/min (13.2 US gpm)
- Max. regulated flow . . . . . : 30 l/min (7.9 US gpm)
- Inlet flow (PPX types) . . . . . : regulated flow +5%
- Max. pressure . . . . . : 350 bar (5100 psi) - PPA types  
315 bar (4600 psi) - PPX types
- Internal leakage (PPX types) . . : 150 cm<sup>3</sup>/min @ 210 bar  
(9.1 in<sup>3</sup>/min @ 3050 psi)

For coil features and options see **BQP19** or **BH** coils on pages 58 and 59.

Inlet section: options

Pressure compensated flow control valve

For sections AN6-AN7-AN11 type

Curves are measured using the standard compensator mounted on section, with 7 bar (100 psi) stand-by.

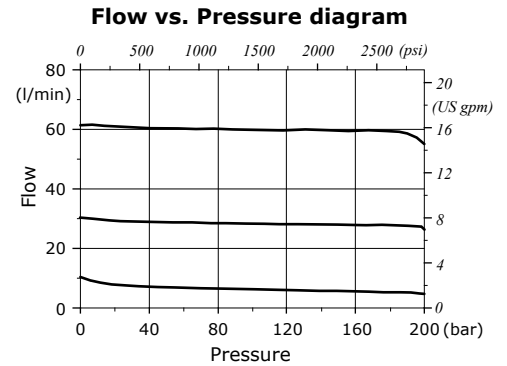
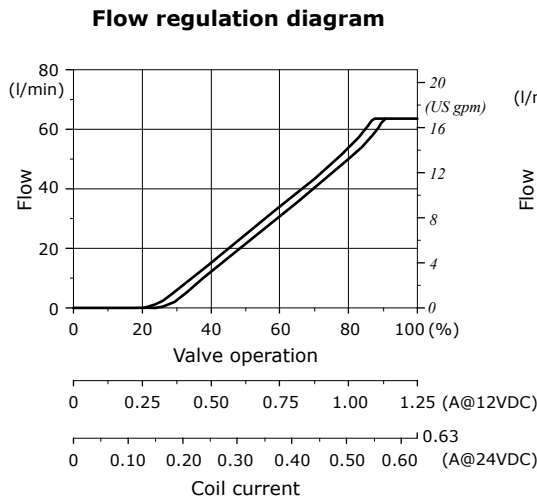
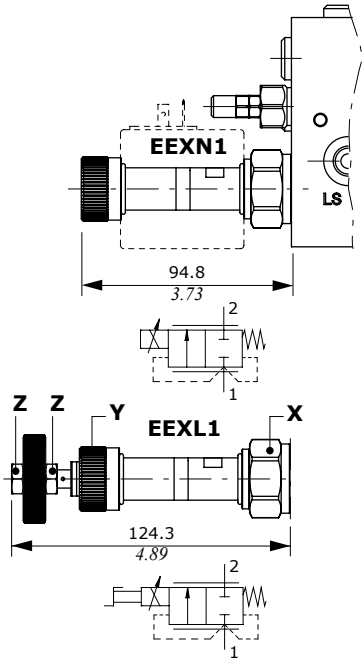

Legenda

- EEXN1: without emergency actuation
- EEXL1: hand-wheel emergency actuation

Wrenches and tightening torque

- K = wrench 10 - 6.6 Nm (4.9 lbf·ft)
- X = wrench 32 - 80 Nm (59 lbf·ft)
- Y = 5 Nm (3.7 lbf·ft)
- Z = wrench 13 - 9.8 Nm (7.2 lbf·ft)

Valve features

- Max. flow . . . . . : 60 l/min (15.8 US gpm)
- Max. pressure . . . . . : 315 bar (4560 psi)
- Internal leakages . . . . . : 200 cm<sup>3</sup>/min @ 150 bar  
(12.2 in<sup>3</sup>/min @ 2175 psi)

For coil features and options see **BQP19** or **BH** coils on pages 58 and 59.

Compensator kit

For sections AN6-AN7-AN11 type

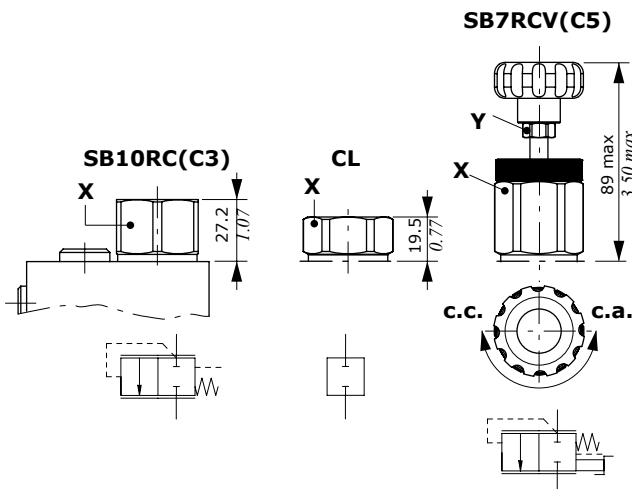

Legenda

- SB7RC(C5): compensator with 7 bar (100 psi) stand-by, for Open Center circuit
- CL: compensator blanking plug, for Closed Center circuit (for AN11 type)
- SB7RCV(C5): compensator with 7 bar (100 psi) stand-by, hand-wheel actuation for Open Center to Closed Center circuit switching

Wrenches and tightening torque

- X = wrench 36 - 42 Nm (31 lbf·ft)
- Y = wrench 13 - 6.6 Nm (4.9 lbf·ft)

Inlet section: options

Pressure compensated flow control valve

For sections AN6B-AN7B-AN11B type

Curves are measured using the standard compensator mounted on section, with 10 bar (145 psi) stand-by.

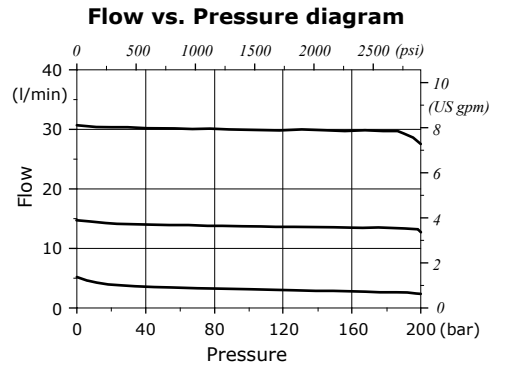
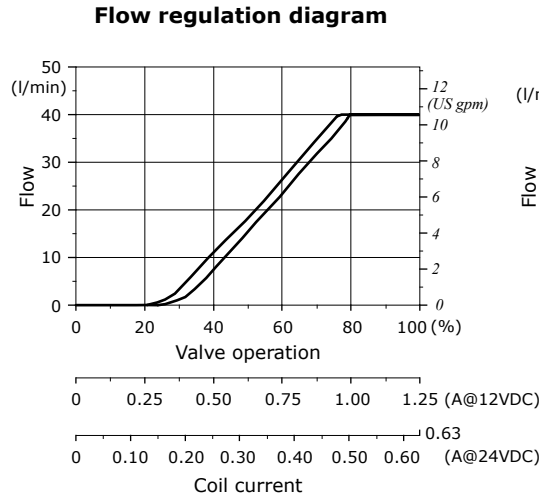
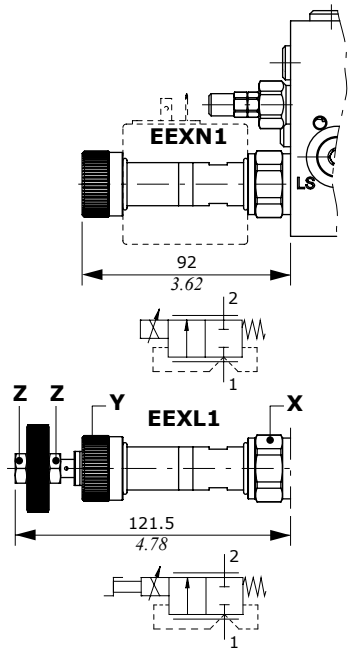

Legenda

- EEXN1: without emergency actuation
- EEXL1: hand-wheel emergency actuation

Wrenches and tightening torque

- K = wrench 10 - 6.6 Nm (4.9 lbft)
- X = wrench 27 - 50 Nm (37 lbft)
- Y = 5 Nm (3.7 lbft)
- Z = wrench 13 - 9.8 Nm (7.2 lbft)

Valve features

- Max. flow . . . . . : 40 l/min (10.6 US gpm)
- Max. pressure . . . . . : 300 bar (5500 psi)
- Internal leakages . . . . . : 150 cm<sup>3</sup>/min @ 150 bar (9.1 in<sup>3</sup>/min @ 2175 psi)

For coil features and options see BQP19 or BH coils on pages 58 and 59.

Compensator kit

For sections AN6B-AN7B-AN11B type

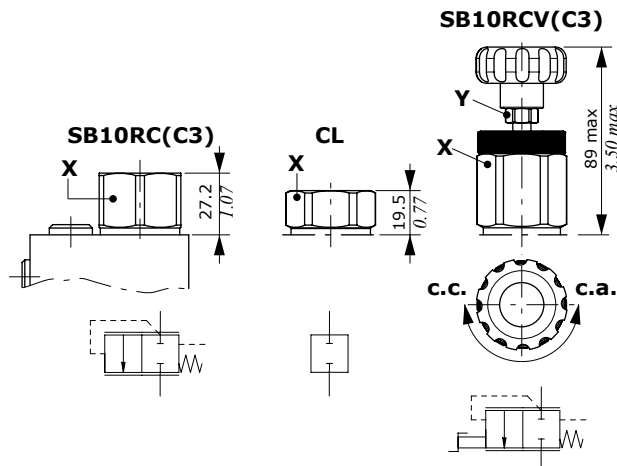

Legenda

- SB10RC(C3): compensator with 10 bar (145 psi) stand-by, for Open Center circuit
- CL: compensator blanking plug, for Closed Center circuit (for AN11B type)
- SB10RCV(C3): compensator with 10 bar (145 psi) stand-by, hand-wheel actuation for Open Center to Closed Center circuit switching

Wrenches and tightening torque

- X = wrench 36 - 42 Nm (31 lbft)
- Y = wrench 13 - 6.6 Nm (4.9 lbft)

## Working section: part ordering codes

SDE060 / P - 1 8ES3 . P3(G3-100) - WC - .....  
 Valve setting (bar)

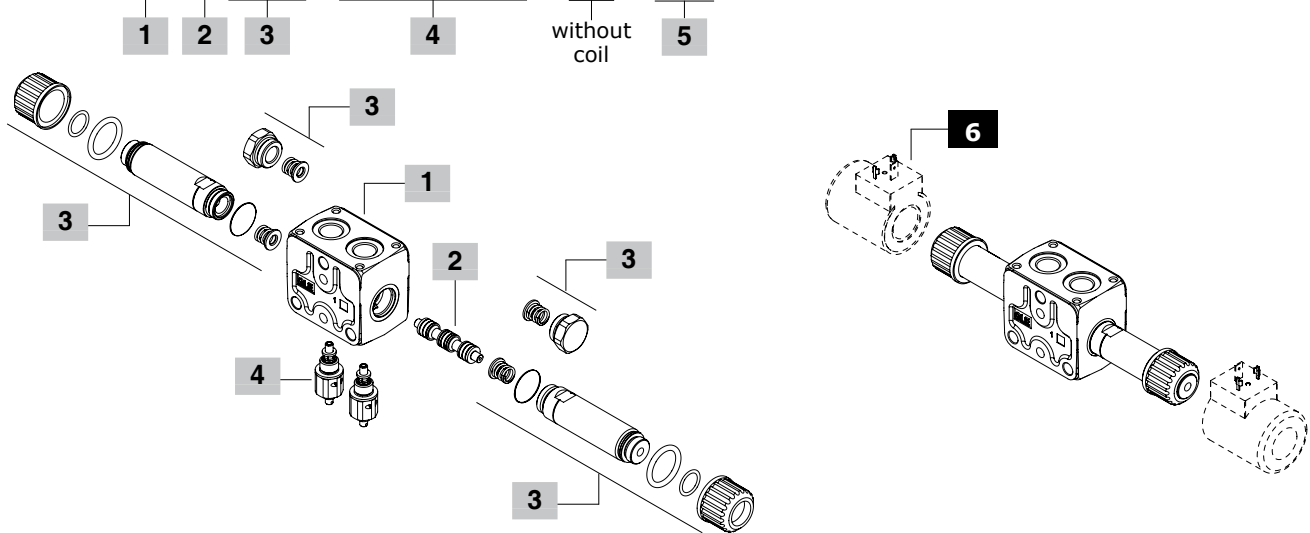

### 1 Working section body kit \* page 47

Section bodies are cast iron made

TYPE	CODE	DESCRIPTION
------	------	-------------

**Sections with standard threads: SAE6**

<b>Q-SAE</b>	5EL1037000	Parallel type, with arrangement for upper flangeable valve block
<b>QS-SAE</b>	5EL2037000	As type Q, for series circuit: <b>need spool type 1S#</b> . <b>Only for section up to 60 l/min (15.8 US gpm)</b>
<b>Q(8)-SAE</b>	5EL1037510	As type Q, for regenerative circuit on port A: <b>need spool type 8</b>
<b>P-SAE</b>	5EL1037010	As type Q, with arrangement for secondary relief valve

**Sections with increased threads: SAE8**

<b>NF-SAE8</b>	5EL1038010	Parallel type, without arrangement for upper flangeable valve block
<b>QSNF-SAE8</b>	5EL1038011	As type Q, for series circuit: <b>needs spool type 1S#</b> . <b>Only for SDE060 valve</b>
<b>QNF(8)-SAE8</b>	5EL1038500	As type Q, for regenerative circuit on port A: <b>needs spool type 8</b>
<b>PNF-SAE8</b>	5EL1038000	As type Q, with arrangement for secondary port valves

### 3 On/off solenoid control page 50

TYPE	CODE	DESCRIPTION
------	------	-------------

**For section up to 60 l/min (15.8 US gpm)**

<b>8ES1</b>	5CAN08E110C	Single acting on port A
<b>8ES2</b>	5CAN08E110C	Single acting on port B
<b>8ES3</b>	5CAN08E111C	Double acting
<b>8ES3LHD</b>	5CAN08E311	Double acting with emergency lever operation: <b>needs dedicated spools</b>
<b>8ES3SE</b>	5CAN08E116C	Double acting: <b>for spool type 1S#</b>

**For section up to 30 l/min (7.9 US gpm)**

<b>8ES1B</b>	5CAN08E114C	Single acting on port A
<b>8ES2B</b>	5CAN08E114C	Single acting on port B
<b>8ES3B</b>	5CAN08E115C	Double acting
<b>8ES3BLHD</b>	5CAN08E315	Double acting with emergency lever operation: <b>needs dedicated spools</b>

### 2 Spool page 49

TYPE	CODE	DESCRIPTION
------	------	-------------

**For ON/OFF solenoid control**

<b>1</b>	3CU9010102	Double acting, A and B closed in neutral pos.
<b>1A</b>	3CU9010103	Double acting, A to tank in neutral pos. For connect B to tank (type <b>1B</b> ) is necessary to turn the spool
<b>2</b>	3CU9025100	Double acting, A and B to tank in neutral pos.
<b>2H</b>	3CU9025225	Double acting, A and B partially to tank in neutral position
<b>1S</b>	3CU9010101	Double acting, for series circuit: <b>needs control type 8ES3SE and section type QS-QSNF#</b>
<b>8</b>	3CU9080100	Double acting, for regenerative circuit, for 30 l/min (7.9 US gpm): <b>needs section type Q8</b>

**For ON/OFF solenoid control with manual lever operation**

<b>1LHD</b>	3CU9010300	As type 1
<b>1ALHD</b>	3CU9010303	As type 1A
<b>2LHD</b>	3CU9020300	As type 2
<b>2HLHD</b>	3CU9020310	As type 2H

### 4 Port relief valves page 48

Standard setting is referred to 10 l/min (2.6 US gpm) flow.

TYPE	CODE	DESCRIPTION
------	------	-------------

<b>P(G3-100)</b>	5KIT060000	From 50 to 200 bar (725 to 2900 psi), standard setting 100 bar (1450 psi)
<b>P(G4-200)</b>	5KIT060001	From 200 to 315 bar (2900 to 4600 psi), standard setting 200 bar (2900 psi)
<b>P3T</b>	5KIT060100	A and B ports valve blanking plugs

### 5 Section threading

Specify threading always when it is different from BSP standard (see page 4).

### 6 Optional coils page 58

For list of available coils see pages of related sections

NOTES (#) - For Series circuit configuration rules see page 29.

(\*) - Codes are referred to **UN-UNF** thread.

Dimensions and hydraulic circuit

Working section Q type

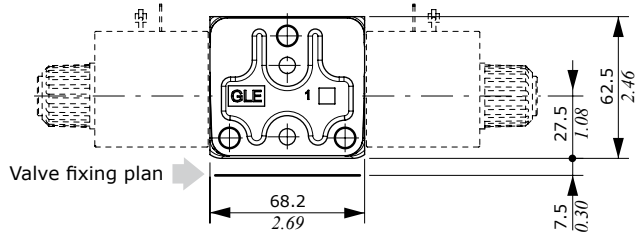

**Standard port thread: SAE6**  
with arrangement for valve blocks

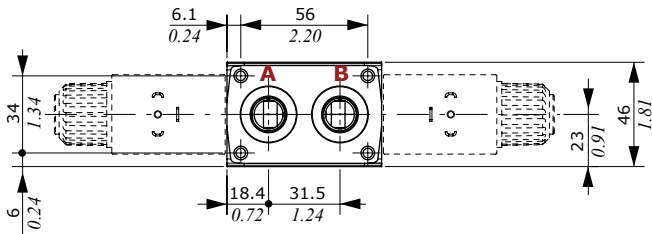

**Increased port thread: SAE8**  
without arrangement for valve blocks (NF type)

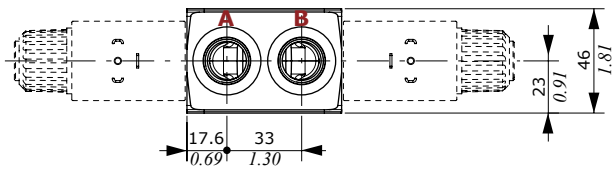

**Q type: parallel circuit**  
(with spool type 1)

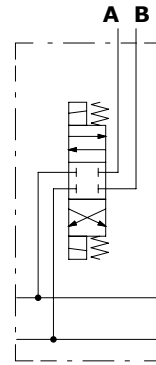

**Q8 type: regenerative circuit**  
(needs spool type 8)

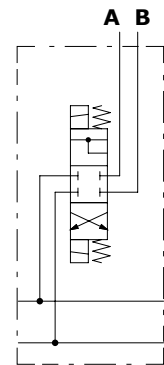

**QS type for series circuit**  
(needs spool type 1S)

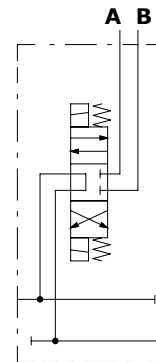

**Flow through pressure drop**  
(parallel and regenerative circuits)

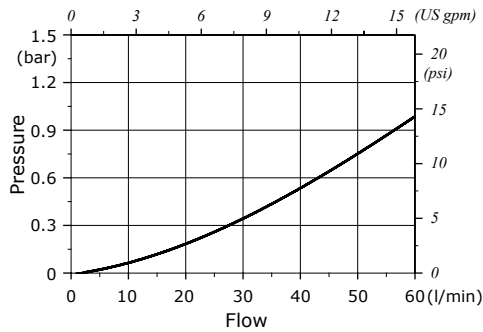

**Flow through pressure drop**  
(QS series section with 1S spool)

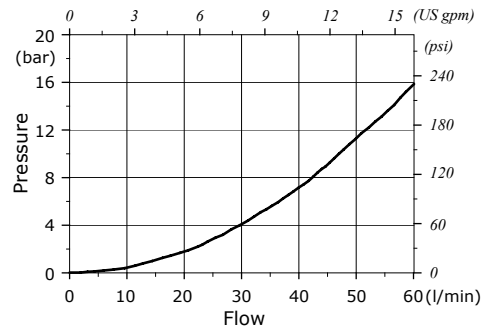

Working section

Dimension and hydraulic circuit

Working section Q type

With arrangement for secondary port valves.

P type section is available also with increased port threads (G1/2): see Q type section for dimensional data.

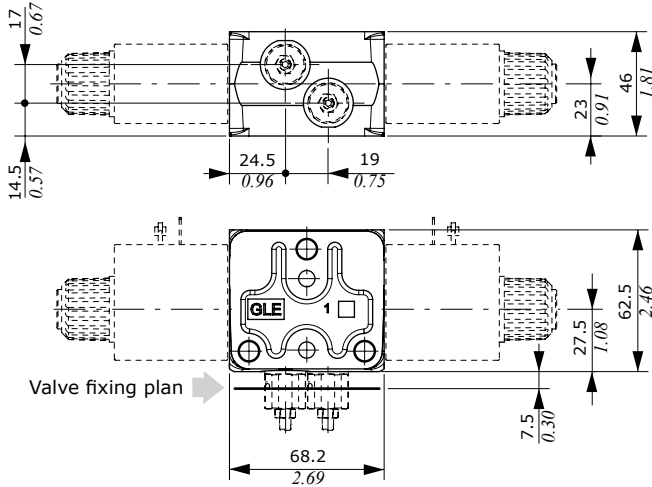

P type: parallel circuit (with spool type 1)

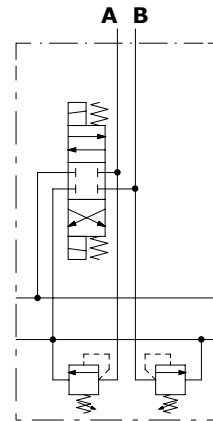

Port relief valves

G type

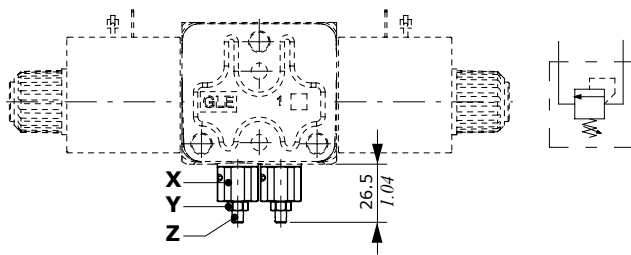

H type

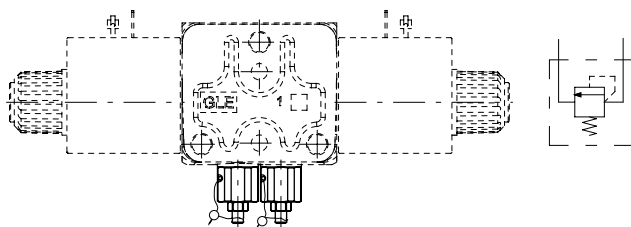

Legenda

- G: screw setting type
- H: valve set and locked

Wrenches and tightening torque

- X = wrench 17 - 24 Nm (17.7 lbf<sub>t</sub>)
- Y = wrench 8 - 6.6 Nm (4.9 lbf<sub>t</sub>)
- Z = allen wrench 2.5

Setting range: G3 type

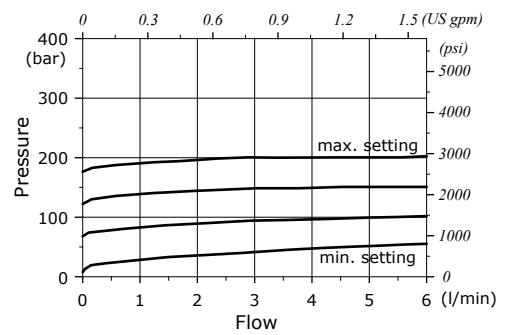

Setting range: G4 type

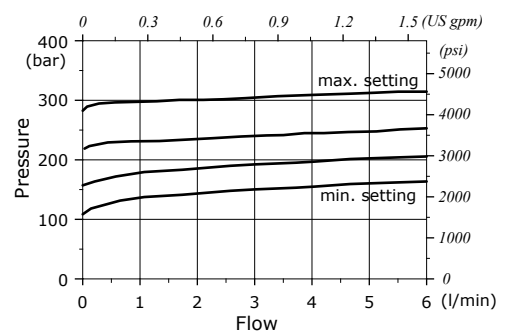



Spools

**Types 1-1LHD**

Double acting, A and B closed in neutral position

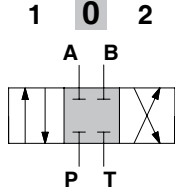

Stroke

position 1: + 3 mm (+ 0.12 in)  
position 2: - 3 mm (- 0.12 in)

**Types 1A-1ALHD**

Double acting, A to tank in neutral position

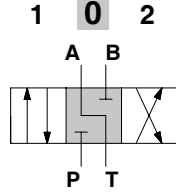

Stroke

position 1: + 3 mm (+ 0.12 in)  
position 2: - 3 mm (- 0.12 in)

**Types 2-2LHD**

Double acting, A and B to tank in neutral position

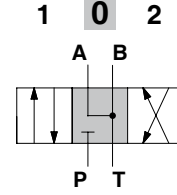

Stroke

position 1: + 3 mm (+ 0.12 in)  
position 2: - 3 mm (- 0.12 in)

**P⇒port - port⇒T pressure drops**  
(curves are matched)

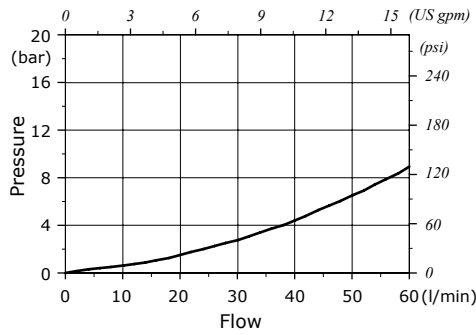

**P⇒port - port⇒T pressure drops**  
(curves are matched)

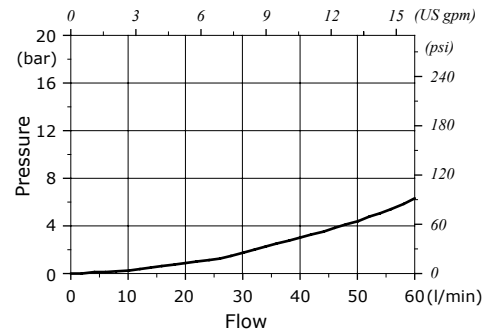

**Types 2H-2HLHD**

Double acting, A and B partially to tank in neutral position

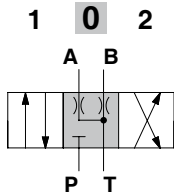

Stroke

position 1: + 3 mm (+ 0.12 in)  
position 2: - 3 mm (- 0.12 in)

**Types 1S**

Double acting, for series circuit

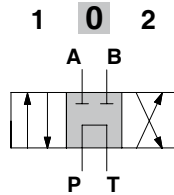

Stroke

position 1: + 3 mm (+ 0.12 in)  
position 2: - 3 mm (- 0.12 in)

**Types 8-8LHD**

Double acting, for regenerative circuit

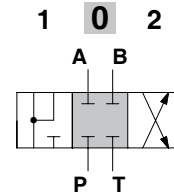

Stroke

position 1: + 3 mm (+ 0.12 in)  
position 2: - 3 mm (- 0.12 in)

**P⇒port - port⇒T pressure drops**  
(curves are matched)

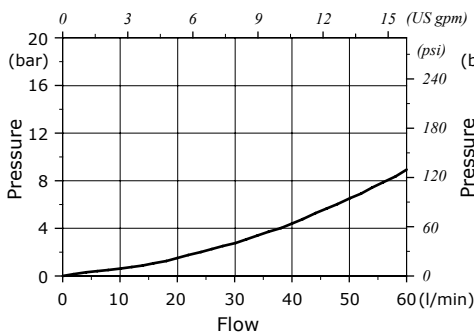

**P⇒port - port⇒T pressure drops**  
(curves are matched)

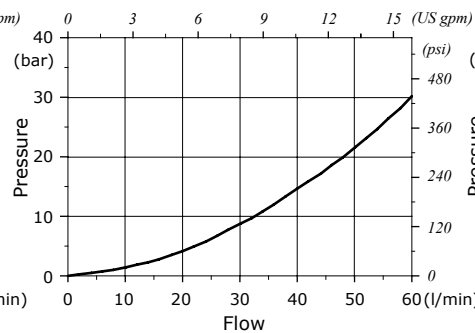

**P⇒port - port⇒T pressure drops**  
indicated for 30 l/min (7.9 US gpm) max

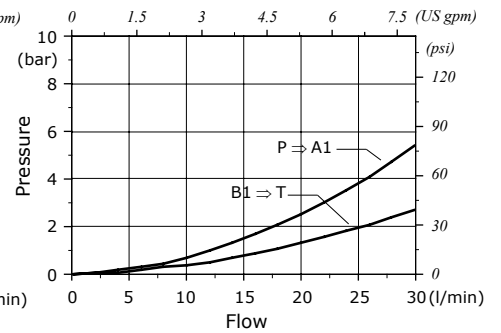

Working section

**On/off solenoid control: 8ES3 - 8ES1 - 8ES2 - 8ES3SE types**

For section configuration up to 60 l/min (15.8 US gpm) flow rate.

When the section is configured with flangeable valve block, the coils on control must be rotated 180°

**8ES3 - 8ES3SE: double acting control kit**

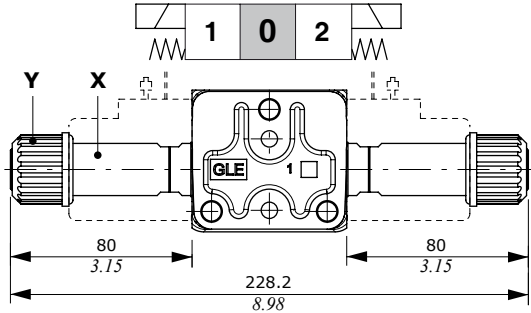

**8ES1: single acting on A control kit**

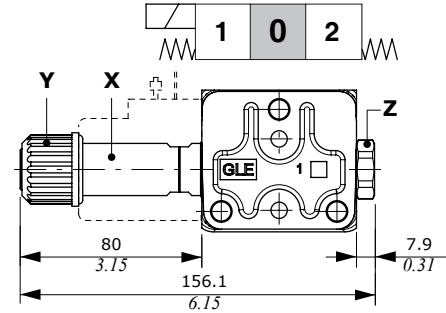

**Operating condition**  
(stroke 3 mm - 0.12 in)

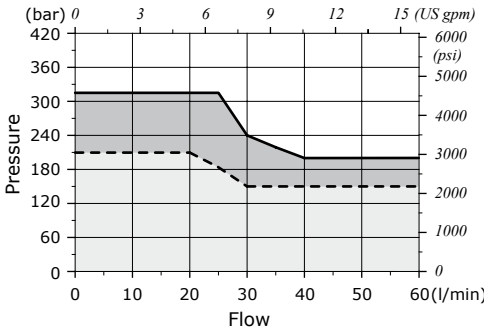

**Wrenches and tightening torque**

- X = wrench 20 - 24 Nm (17.7 lbft)
- Y = 15 Nm (11 lbft)
- Z = wrench 24 - 24 Nm (17.7 lbft)

For coil options and features see **D15C** coil on pages 58 and 60.

- SDE060 with 8ES3 control kit; parallel circuit
- - - SDE060 with 8ES3SE control kit; series circuit

**8ES2: single acting on B control kit**

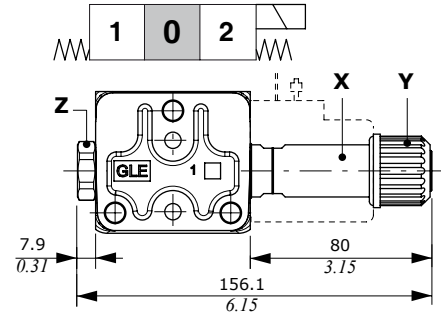

**On/off solenoid control with lever: type 8ES3LHD**

For section configuration up to 60 l/min (15.8 US gpm) flow rate; this control is not suitable for series circuit.

To properly operation the coil on lever side must be rotated 10° (figure A).

When the section is configured with flangeable valve block, the control (with coil) must be rotated 180°.

The control needs dedicated spools: see page 44 for list.

IMPORTANT: lever to be used only for emergency operation, not for continuative use.

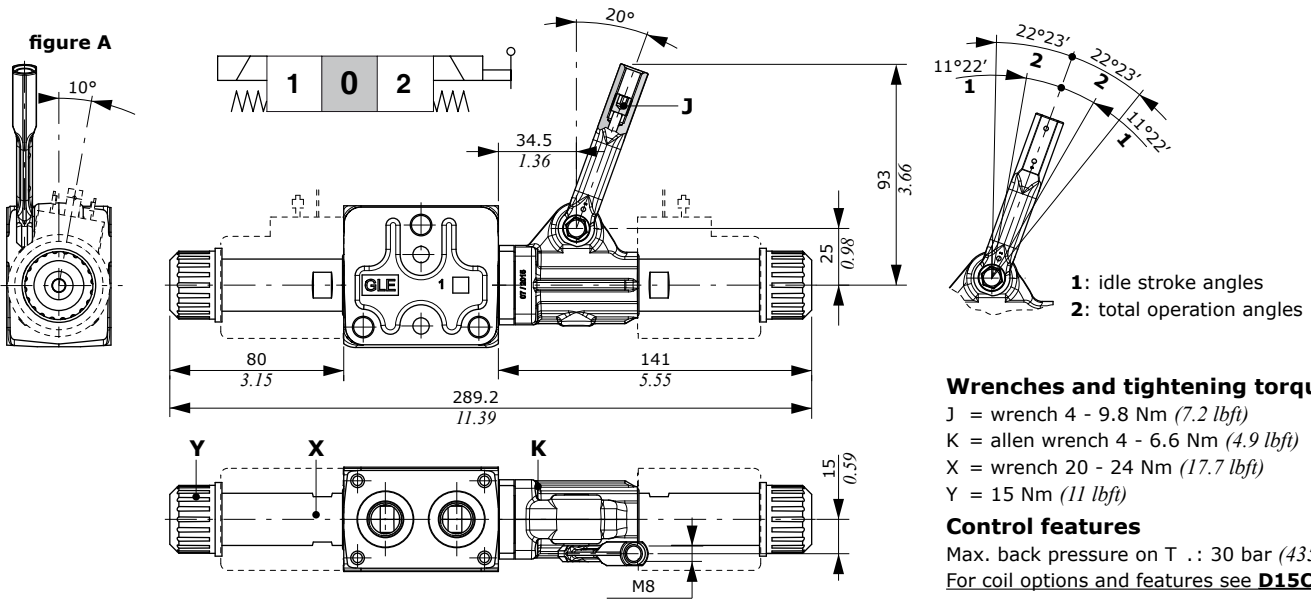

**Wrenches and tightening torque**

- J = wrench 4 - 9.8 Nm (7.2 lbft)
- K = allen wrench 4 - 6.6 Nm (4.9 lbft)
- X = wrench 20 - 24 Nm (17.7 lbft)
- Y = 15 Nm (11 lbft)

**Control features**

Max. back pressure on T : 30 bar (435 psi)  
For coil options and features see **D15C** coil on pages 58 and 60.

**On/off solenoid control: 8ES3B - 8ES1B - 8ES2B types**

For section configuration up to 30 l/min (7.9 US gpm) flow rate; control is not suitable for series circuit  
 When the section is configured with flangeable valve block, the coils on control must be rotated 180°

**8ES3B: double acting control kit**

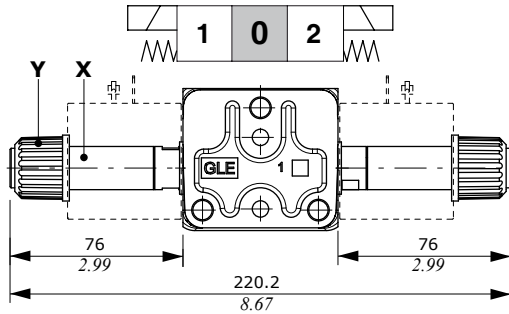

**8ES1B: single acting on A control kit**

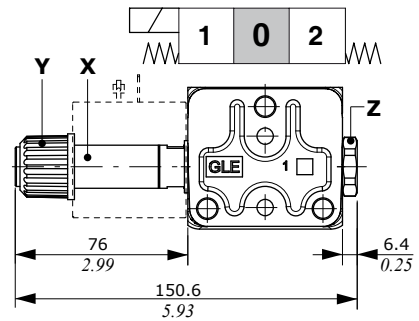

**8ES2B: single acting on B control kit**

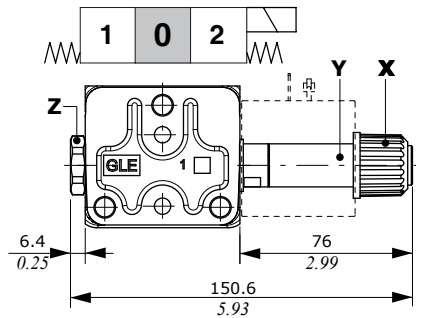

**Operating condition**  
(stroke 3 mm - 0.12 in)

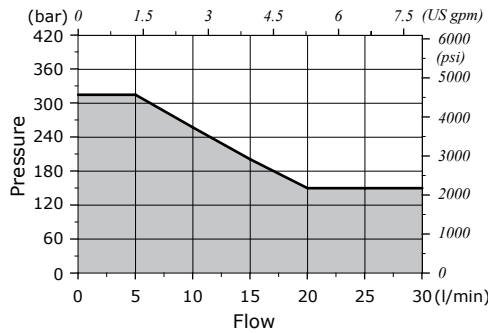

**Wrenches and tightening torque**

- X = wrench 17 - 24 Nm (17.7 lbft)
- Y = 6.6 Nm (4.9 lbft)
- Z = wrench 24 - 24 Nm (17.7 lbft)

For coil options and features see **D12C** coil on pages 58 and 60.

**On/off solenoid control with lever: 8ES3BLHD type**

For section configuration up to 30 l/min (7.9 US gpm) flow rate; this control is not suitable for series circuit  
 When the section is configured with flangeable valve block, the control (with coil) must be rotated 180°. The control needs dedicated spools: see page 44 for list.  
**IMPORTANT:** lever to be used only for emergency operation, not for continuative use.

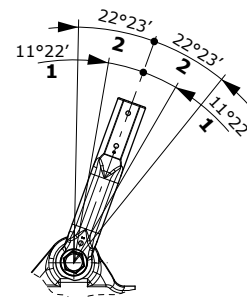
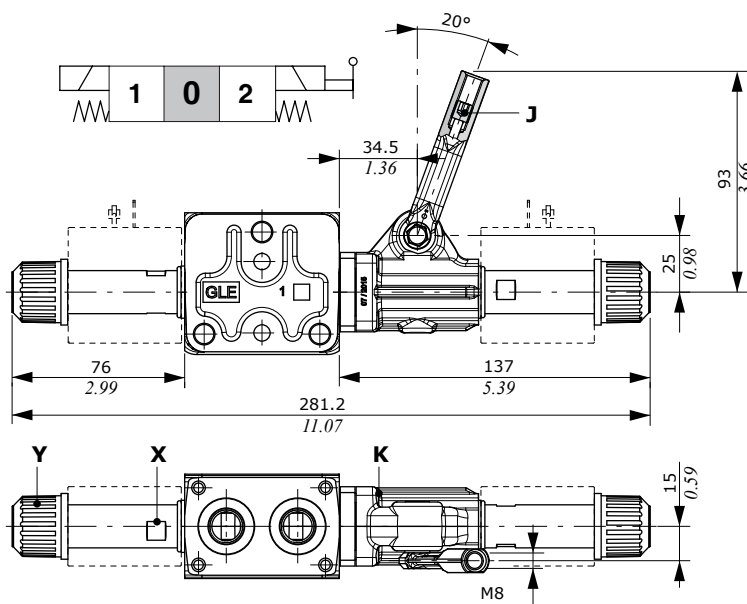

- 1: idle stroke angles
- 2: total operation angles

**Wrenches and tightening torque**

- J = wrench 4 - 9.8 Nm (7.2 lbft)
- K = allen wrench 4 - 6.6 Nm (4.9 lbft)
- X = wrench 17 - 24 Nm (17.7 lbft)
- Y = 6.6 Nm (4.9 lbft)

**Control features**

Max. back pressure on T : 30 bar (435 psi)  
 For coil options and features see **D12C** coil on pages 58 and 60.

Flangeable valve blocks

Antishock valves with cross operation

8ES on/off solenoid controls (with or without lever operation) must be rotated 180°.

PS3 type: valves on both ports

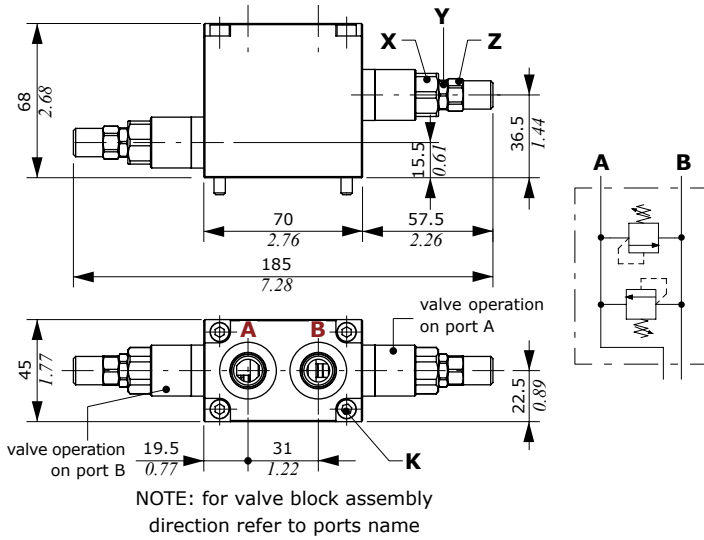

PS1 or PS2 types: valve on single port

(PS1 type is drawn: PS2 type has the valve mounted on the opposite side and the same dimensions)

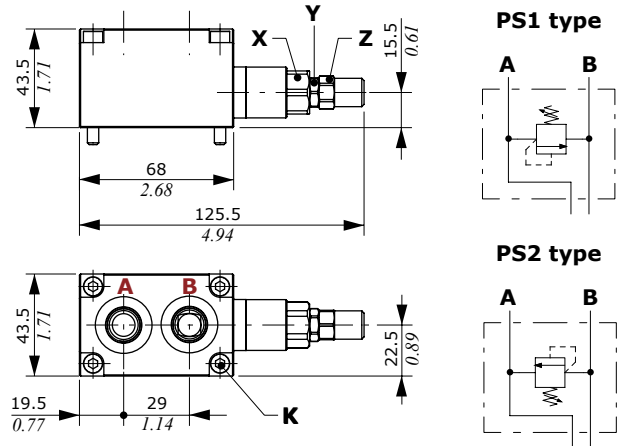

Ordering codes

TYPE	CODE	DESCRIPTION
<b>Complete antishock valves</b>		
PS1(DC3-160)-SAE	619001001	Valve with operation on port A
PS2(DC3-160)-SAE	619001001	Valve with operation on port B
PS3(DC3-160\DC4-200)-SAE	619001104	Valves with operation on port A (160) and B (200)

Part #1: Valve kit

Valve standard setting is referred to 5 l/min (1.3 US gpm) flow, considering the valve mounted on block.

(DC2-60)	1100520460	Range 20-80 bar (290-1150 psi) std setting 60 bar (870 psi)
(DC3-160)	1100520408	Range 50-220 bar (725-3200 psi) std setting 160 bar (2300 psi)
(DC4-280)	1100520414	Range 180-350 bar (2600-5100 psi) std setting 280 bar (4050 psi)
PST	XTAP623282	Valve blanking plug

Part #2: Block body kit

PS1-PS2-SAE	5COR245683	For single valve on port A or B
PS3-SAE	5COR245681	For valves on port A and B

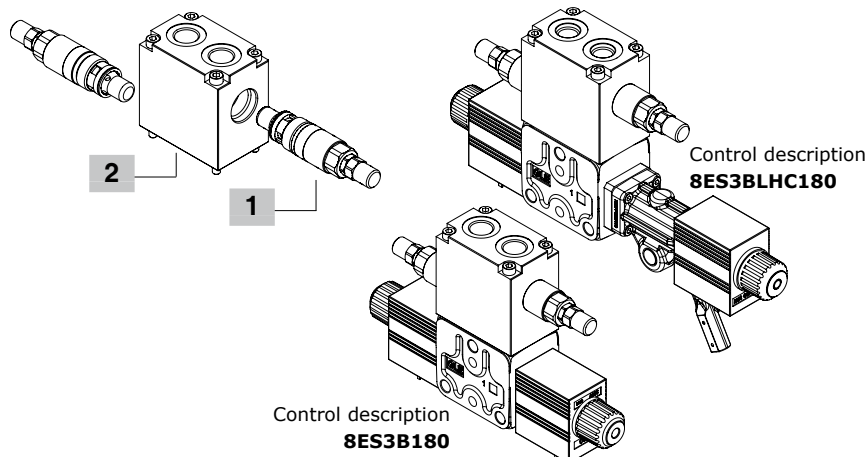

Wrenches and tightening torque

- K = allen wrench 4 - 9.8 Nm (7.2 lbft)
- X = wrench 19 - 42 Nm (31 lbft)
- Y = wrench 13 - 24 Nm (17.7 lbft)
- Z = wrench 13 - 6.6 Nm (4.9 lbft)

Antishock valve pressure drops

P⇒port - port⇒T (curves are matched)

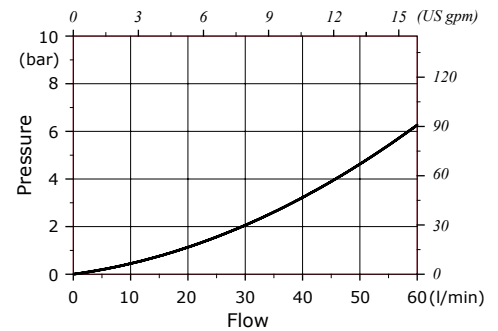

Setting range

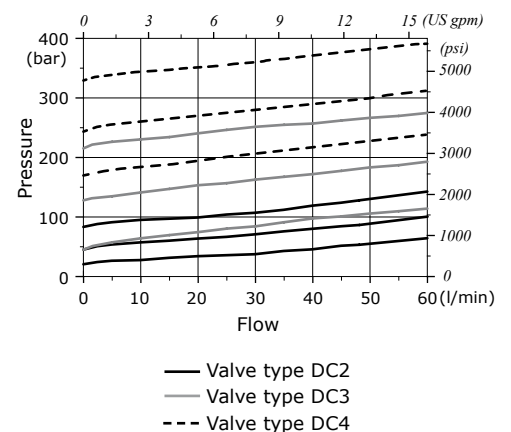

Flangeable valve blocks

Check valves

8ES on/off solenoid controls (with or without lever operation) must be rotated 180°.

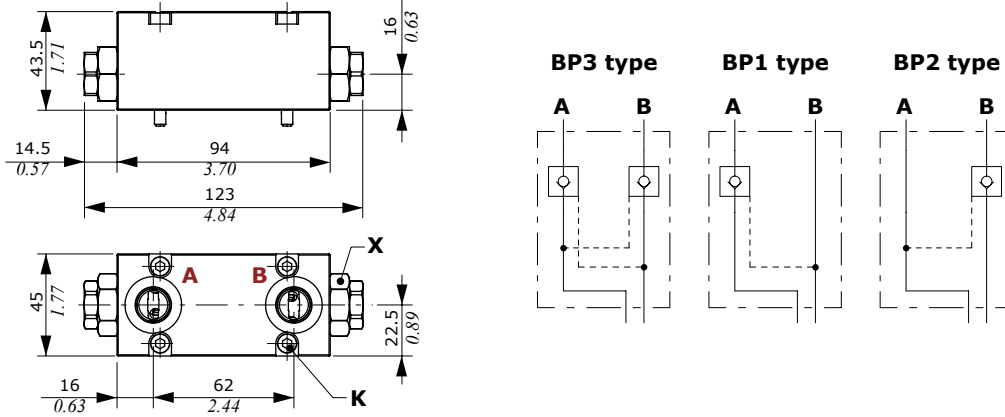

Wrenches and tightening torque

- K = allen wrench 4 - 9.8 Nm (7.2 lbft)
- X = wrench 29 - 42 Nm (31 lbft)

Ordering codes

TYPE	CODE	DESCRIPTION
<b>Complete valve block</b>		
BP1-SAE	619002001	Valve on port A
BP2-SAE	619002001	Valve on port B
BP3-SAE	619002101	Valves on ports A and B
<b>Part #1: Valve kit</b>		
BP	1300020402	Check valve
TBP	XTAP627260	Valve blanking plug
<b>Part #2: Body kit and piston</b>		
	5COR245891	Block body kit
	3PIS214480	Piston

Check valve pressure drop

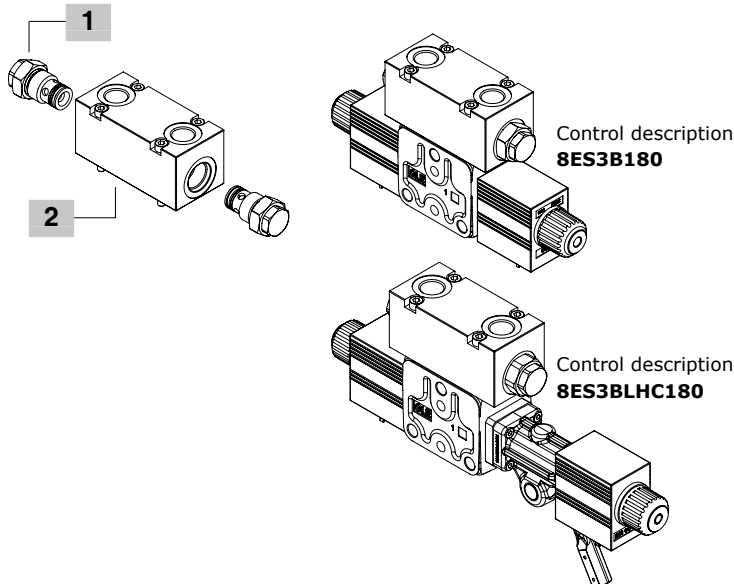
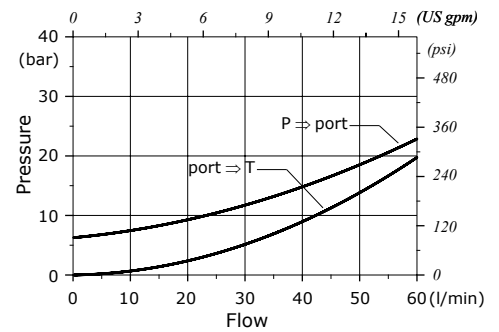

Flangeable valve blocks

Solenoid operated check valves

8ES on/off solenoid controls (with or without lever operation) must be rotated 180°.

BPE(NC) type: normally closed circuit

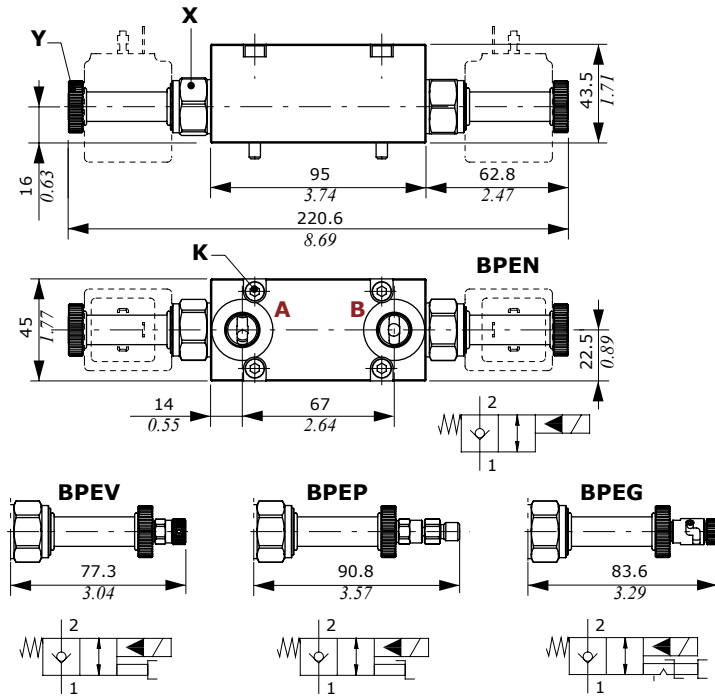

BPEN3(NC) type

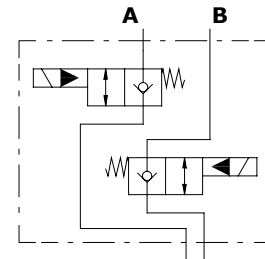

BPEN1(NC) type

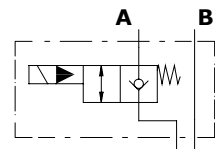

BPEN2(NC) type

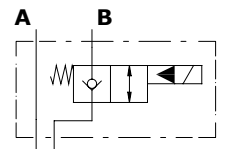

Wrenches and tightening torque

K = allen wrench 4 - 9.8 Nm (7.2 lbf<sub>t</sub>)

X = wrench 24 - 30 Nm (22 lbf<sub>t</sub>)

Y = 5 Nm (3.7 lbf<sub>t</sub>)

BPE(NA) type: normally open circuit

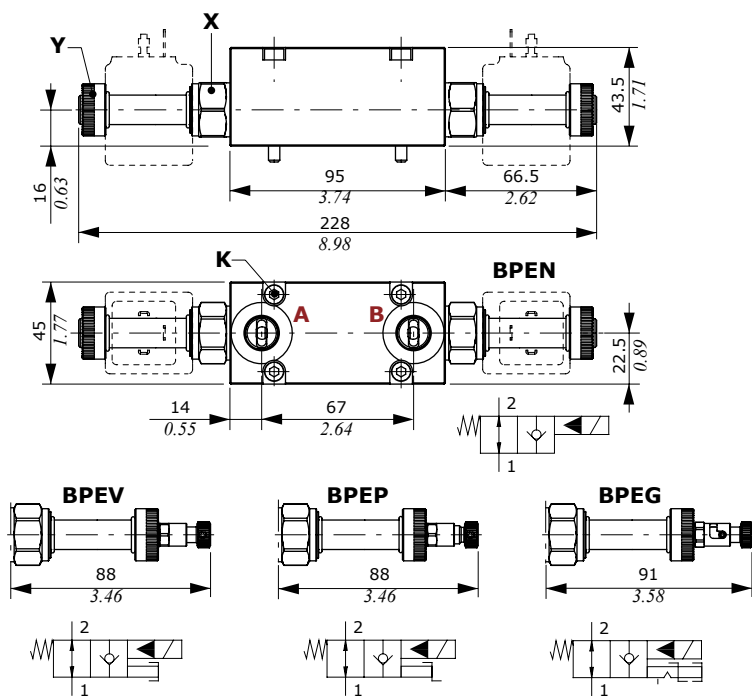

BPEN3(NA) type

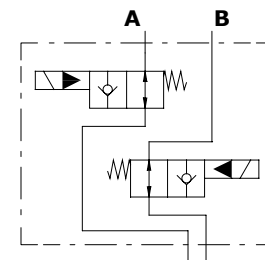

BPEN3(NA) type

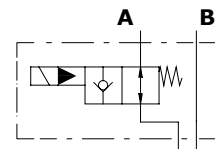

BPEN3(NA) type

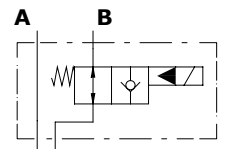

Flangeable valve blocks

Solenoid operated check valves

Check valve pressure drop  
(curves without section)

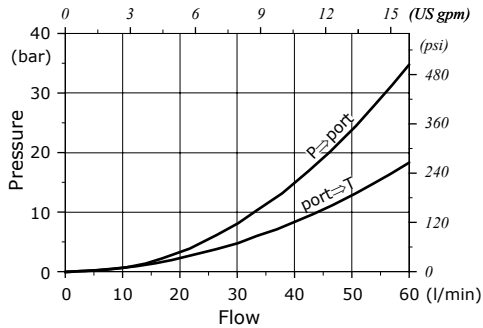

Ordering codes

TYPE	CODE	DESCRIPTION
<b>Complete valve block, without coil</b>		
<b>BPEN1(NC)-WC-SAE</b>	Y64S367001	On ports A, NC circuit, without manual emergency
<b>BPEN2(NC)-WC-SAE</b>	Y64S367001	As previous, on port B
<b>BPEN3(NC)-WC-SAE</b>	Y64S367000	As previous, on ports A and B
<b>Part #1: Valve kit</b>		
<b>TBPE</b>	3XTAP822150	Valve blanking plug
<b>Normally closed circuit</b>		
<b>BPEN(NC)</b>	0EC08002032	Without manual emergency
<b>BPEV(NC)</b>	0EC08002037	With screw type emergency
<b>BPEP(NC)</b>	0EC08002036	With pull-button emergency
<b>BPET(NC)</b>	0EC08002038	With "pull & twist" emergency
<b>Normally open circuit</b>		
<b>BPEN(NA)</b>	0EC08002031	Without manual emergency
<b>BPEV(NA)</b>	0EC08002034	With screw type emergency
<b>BPEP(NA)</b>	0EC08002033	With push-button emergency
<b>BPET(NA)</b>	0EC08002035	With "push & twist" emerg.
<b>Part #2: Block body kit</b>		
<b>BPE3-SAE</b>	5COR245951	Block body kit
<b>Part #3: Coil</b>		
Valves needs type BER coil, see page 58.		

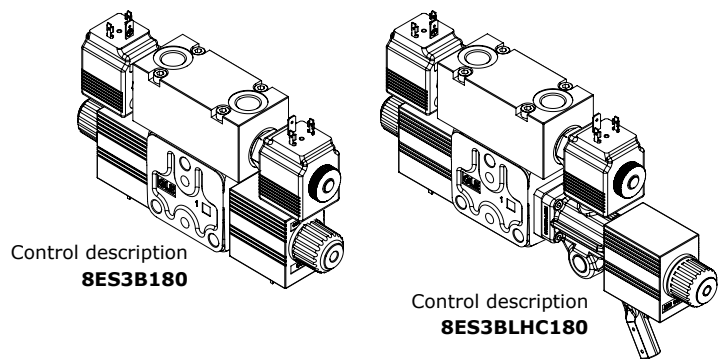
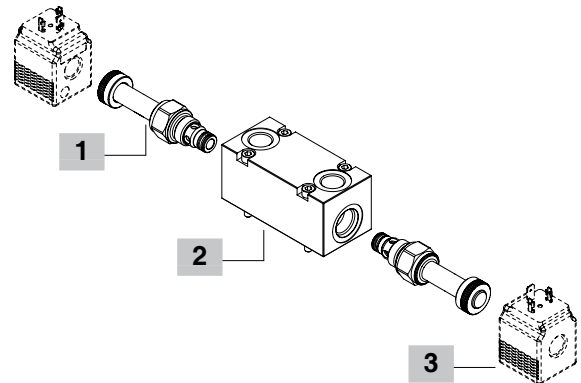

Flangeable valve blocks

Counterbalance valves

8ES on/off solenoid controls (with or without lever operation) must be rotated 180°.

Double acting valve

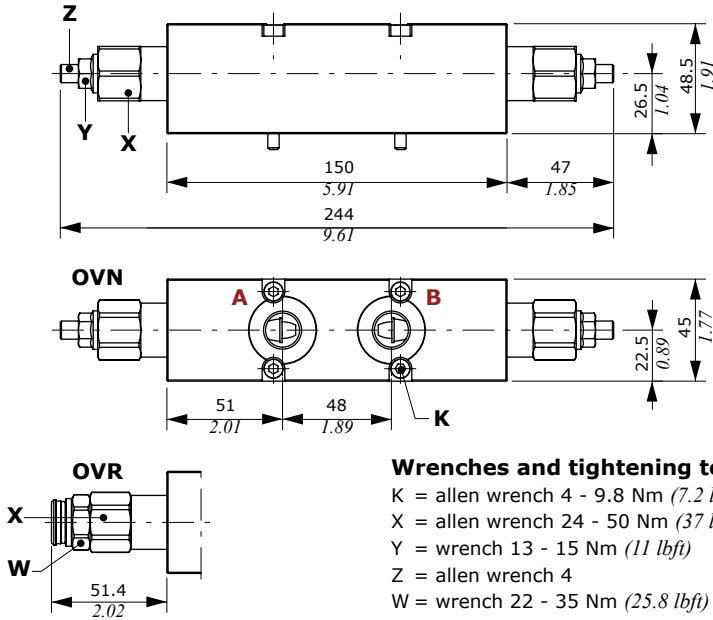

Single acting valve

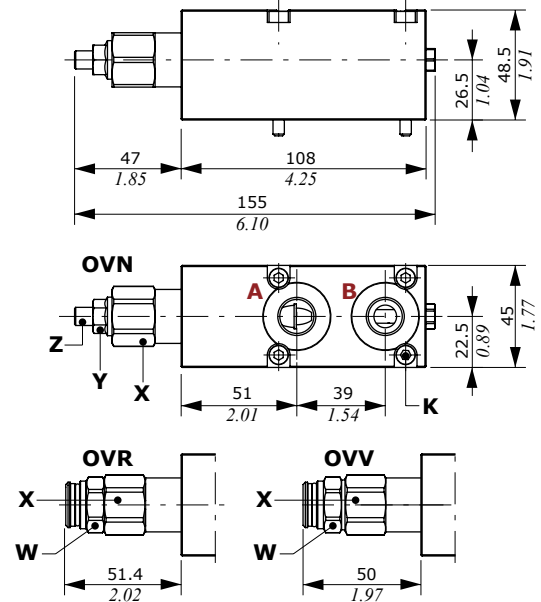

Wrenches and tightening torque

- K = allen wrench 4 - 9.8 Nm (7.2 lbft)
- X = allen wrench 24 - 50 Nm (37 lbft)
- Y = wrench 13 - 15 Nm (11 lbft)
- Z = allen wrench 4
- W = wrench 22 - 35 Nm (25.8 lbft)

OVN301 type

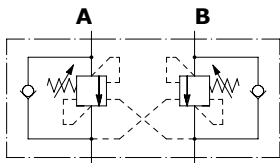

OVR301 type

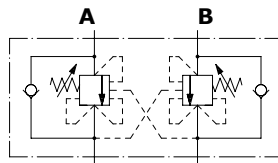

OVR101 type

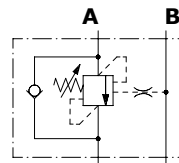

OVR101 type

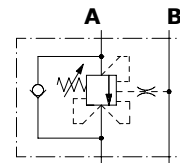

OVV101 type

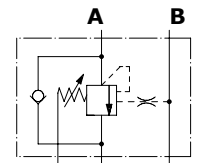

Ordering codes

TYPE CODE DESCRIPTION

Single counterbalance valves

- OVN101-SAE** 1515322200 On port A, load sensitive, pilot ratio = 4
- OVN201-SAE** 1515322200 As previous, on ports B
- OVR101-SAE** 1515422200 On port A, relief comp., pilot ratio = 4
- OVR201-SAE** 1515422200 As previous, on ports B
- OVV101-SAE** 1515522200 On port A, vented type, pilot ratio = 4
- OVV201-SAE** 1515522200 As previous, on port B

Double counterbalance valves

- OVN301-SAE** 1555222200 Load sensitive, pilot ratio = 4
- OVR301-SAE** 1555322200 Relief compensated, pilot ratio = 4

OVN201 type

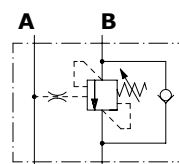

OVR201 type

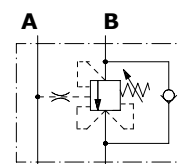

OVV201 type

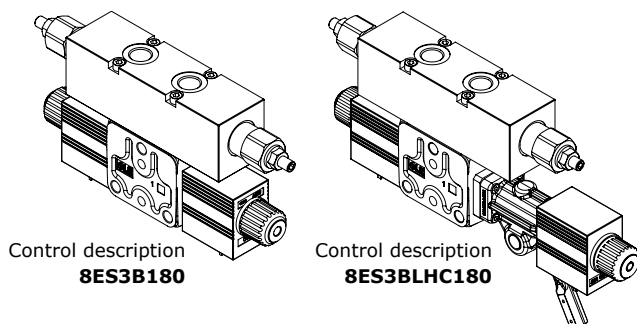
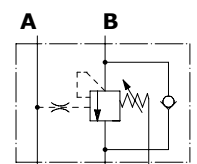

Counterbalance valves pressure drop

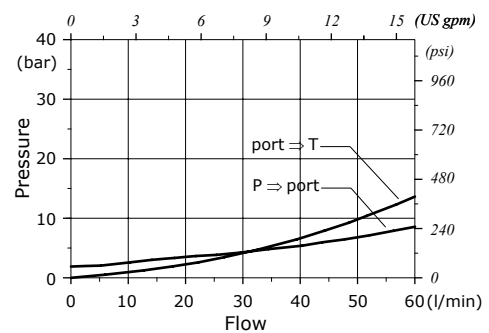



Dimensions and hydraulic circuit

Without port arrangement

RF type

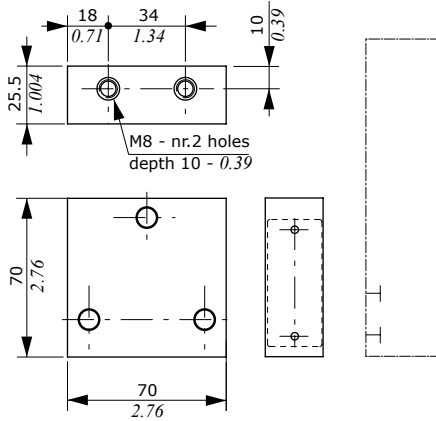

With ports arrangement

RS - RP - RT types  
drawing shows type RS

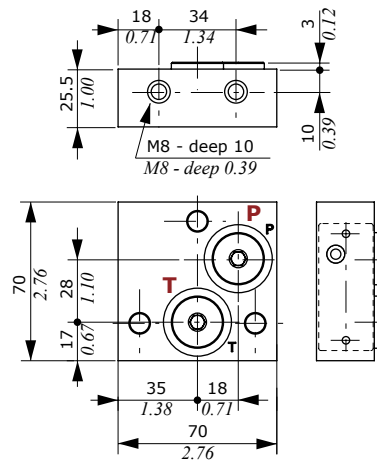

Wrenches and tightening torque

X = allen wrench 8 - 24 Nm (17.7 lbf)  
Y = allen wrench 6 - 24 Nm (17.7 lbf)

RS-RSB types

P and T ports plugged



RP-RPB types

P open, T plugged

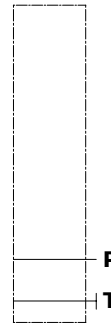

RT-RTB types

T open, P plugged

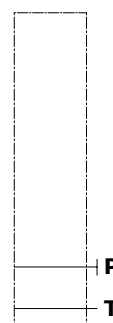

## Accessories

### Coils and connectors

Application on	Coil type	Voltage	Connectors						
			ISO4400	Deutsch DT	AMP JPT	Packard Weatherpack	Packard Metri-pack	Flying leads (without connector)	
Solenoid operated unloading valve	BER	10 VDC	4SLE001000A	-	-	-	-	-	
		12 VDC	4SLE001200A	4SLE001201A <sup>(5)</sup>	4SLE001203A <sup>(4)</sup>	4SLE001210A <sup>(2)</sup>	4SLE001214A <sup>(2)</sup>	4SLE001207A	
			4SLE001217A <sup>(3)</sup>	4SLE001202A <sup>(5)</sup>	4SLE001211A <sup>(3-4)</sup>	-	-	-	
			-	4SLE001216A <sup>(3-5)</sup>	-	-	-	-	
		14 VDC	-	4SLE001400A <sup>(5)</sup>	4SLE001403A <sup>(3-4)</sup>	-	-	-	
			-	4SLE001401A <sup>(3-5)</sup>	4SLE001402A <sup>(3-4)</sup>	-	-	-	
		24 VDC	4SLE002400A	4SLE002401A <sup>(4)</sup>	4SLE002403A <sup>(4)</sup>	-	-	4SLE002404A	
			4SLE002408A <sup>(3)</sup>	4SLE002407A <sup>(3-4)</sup>	-	-	-	-	
		28 VDC	-	4SLE002400A <sup>(1)</sup>	4SLE002402A <sup>(5)</sup>	4SLE002800A <sup>(4)</sup>	-	-	-
			-	-	-	-	-	-	
48 VDC	4SLE004800A	4SLE004800A <sup>(1)</sup>	-	-	-	-	-		
	-	-	-	-	-	-			
110VDC	4SLE011000A	4SLE311000A <sup>(1)</sup>	-	-	-	-	-		
	-	-	-	-	-	-			
220 VDC	4SLE022000A	4SLE322000A <sup>(1)</sup>	-	-	-	-	-		
	-	-	-	-	-	-			
Pressure compensated flow control valve	BQP19	12VDC	4SL5000126A	4SL5000125A <sup>(5)</sup>	4SL5000129A <sup>(4)</sup>	-	-	-	
		24VDC	4SL5000245A	4SL5000244A <sup>(5)</sup>	4SL5000248A <sup>(4)</sup>	-	-	-	
	BH	12VDC	4SLD001200A	4SLD001201A <sup>(5)</sup>	4SLD001202A <sup>(4)</sup>	-	-	4SLD001203A	
		24VDC	4SLD002400A	4SLD002401A <sup>(5)</sup>	4SLD002402A <sup>(4)</sup>	-	-	4SLD002403A	
	D12C	12VDC	4SOL412011-C	-	-	-	-	-	
		24VDC	4SOL412012-C	4SOL412013-C <sup>(5)</sup>	4SOL412014-C <sup>(4)</sup>	-	-	4SOL412019-C	
Controls	D15C	12VDC	4SOL412024-C	4SOL412025-C <sup>(5)</sup>	4SOL412026-C <sup>(5)</sup>	-	-	-	
		14VDC	4SOL515012-C	4SOL515014-C <sup>(3-5)</sup>	-	-	-	4SOL515019-C 4SOL515020-C <sup>(3)</sup>	
	24VDC	-	-	4SOL515016A-C <sup>(4)</sup>	-	-	-	-	
		4SOL515024-C	4SOL515025-C <sup>(3-5)</sup>	-	-	-	-	-	

Notes: (1) supply with AC and use only with rectifier connector - (2) with flying leads - (3) with bidirectional diode - (4) integrated perpendicular type - (5) integrated parallel type

### BQP19 type

ISO4400 connector

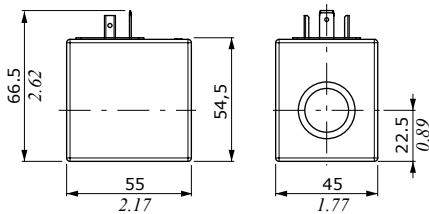

DEUTSCH DT04 connector

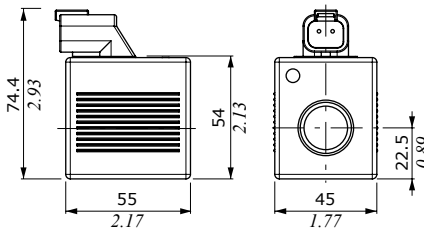

AMP JPT connector

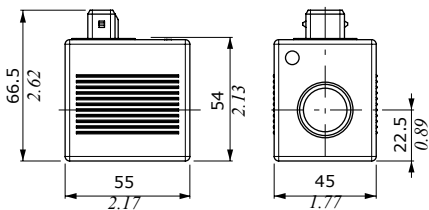

### Features

- Nominal voltage tolerance : ±10%
- Power rating . . . . . : 15 W @ 12 VDC  
: 15 W @ 24 VDC
- Max. operating current . . . : 1.25 A @ 12 VDC  
: 0.63 A @ 24VDC
- Coil insulation . . . . . : Class H  
(180°C - 356°F)
- Weather protection . . . . . : IP65 - ISO4400  
: IP69K - Deutsch DT  
: IP65 - AMP JPT
- Insertion . . . . . : 100%

### Coils and connectors

#### BH type

**ISO4400 connector**

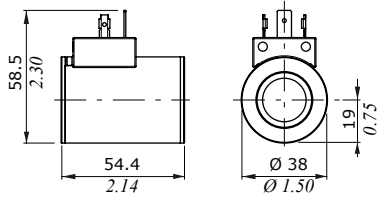

**DEUTSCH DT04 connector**

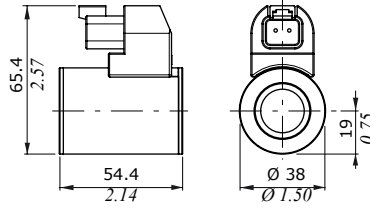

**Features**

- Nominal voltage tolerance : ±10%
- Power rating . . . . . : 33 W - 12/24 VDC
- Max. oper. current (on/off) . . . . . : 2.75 A - 12 VDC  
: 1.38 A - 24 VDC
- Max. prop. control current . . . . . : 1.7 A - 12 VDC  
: 0.85 A - 24 VDC
- Coil insulation . . . . . : Class H  
(180°C - 356°F)
- Weather protection . . . . . : IP65 - ISO4400  
: IP69K - Deutsch DT  
: IP65 - AMP JPT
- Insertion . . . . . : 100%

**AMP JPT connector**

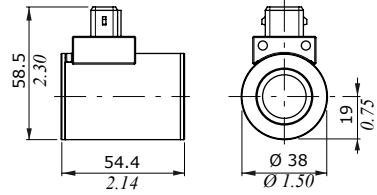

**Flying leads**

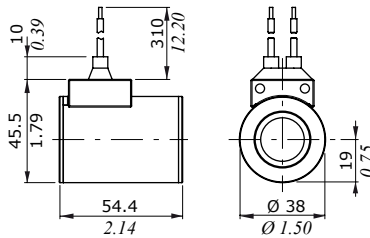

#### BER type

**ISO4400 connector**

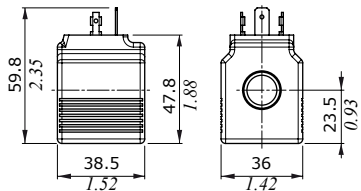

**DEUTSCH DT04 connector  
(perpendicular type)**

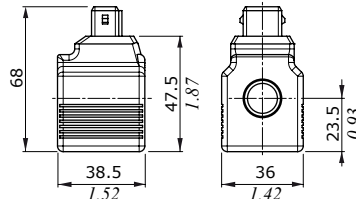

**Features**

- Nominal voltage tolerance : ±10%
- Power rating . . . . . : 19.2 W @ 10/12/24/48/  
110/220 VDC  
: 19 W @ 24/110/220 RAC
- Max. operating current . . . . . : 1.9 A @ 10 VDC  
: 1.61 A @ 12 VDC  
: 0.80 A @ 24 VDC  
: 0.40 A @ 48 VDC  
: 0.17 A @ 110 VDC  
: 0.09 A @ 220 VDC
- Coil insulation . . . . . : Class H (180°C - 356°F)
- Weather protection . . . . . : IP65 - ISO4400  
: IP69K - Deutsch DT  
: IP65 - AMP JPT  
: IP67 - Weatherpack  
: IP67 - Metri-pack
- Insertion . . . . . : 100%

**DEUTSCH DT04 connector  
(parallel type)**

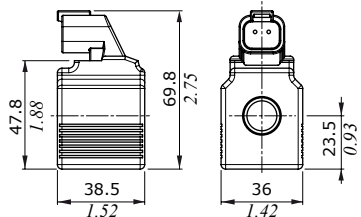

**AMP JPT connector**

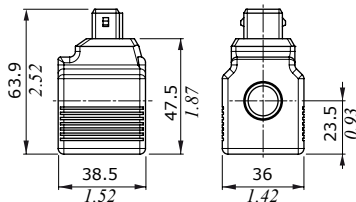

**Flying leads**

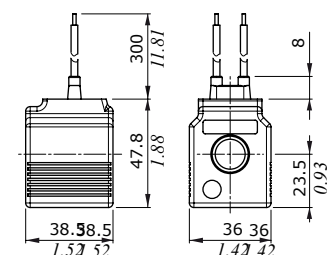

**Flying leads with  
DEUTSCH DT04 connector**

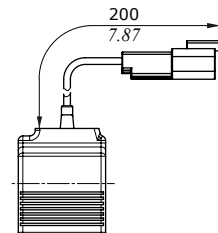

**Flying leads with PACKARD  
WEATHER-PACK connector**

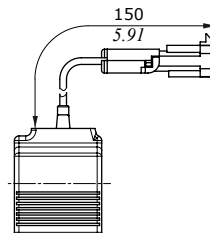

**Flying leads with PACKARD  
METRI-PACK connector**

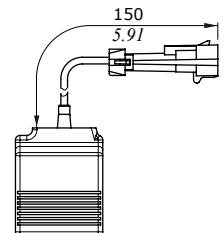

## Accessories

### Coils and connectors

#### D12C type

**ISO4400 connector**

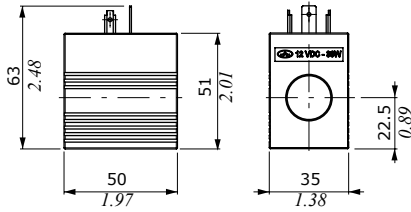

**DEUTSCH DT04 connector**

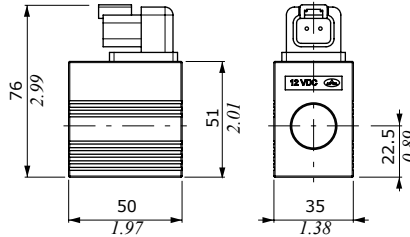

**Features**

- Nominal voltage tolerance : ±10%
- Power rating . . . . . : 36 W @  
 . . . . . : 10.5/12/24 VDC
- Max. operating current . . . : 3.43 A @ 10.5 VDC  
 : 3 A @ 12 VDC  
 : 1.5 A @ 24VDC
- Coil insulation . . . . . : Class H (180°C - 356°F)
- Weather protection . . . . . : IP65 - ISO4400  
 : IP69K - Deutsch DT  
 : IP65 - AMP JPT
- Insertion . . . . . : 100%

**Flying leads**

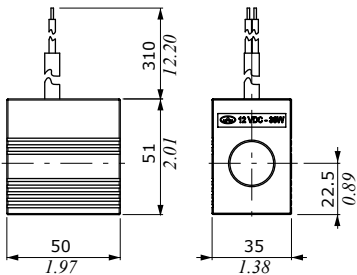

**Flying leads with DEUTSCH DT04 connector**

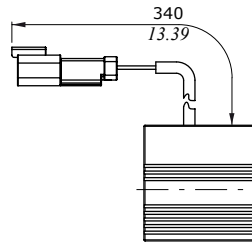

**AMP JPT connector**

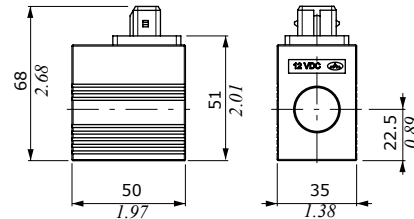

#### D15C type

**ISO4400 connector**

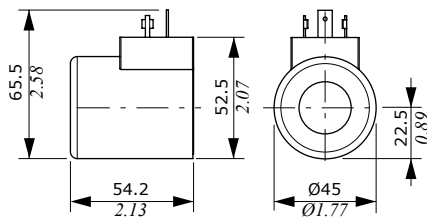

**DEUTSCH DT04 connector**

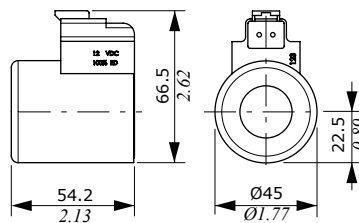

**Features**

- Nominal voltage tolerance : ±10%
- Power rating . . . . . : 38 W @  
 . . . . . : 12/14/24/ VDC
- Max. operating current . . . : 3.16 A @ 12 VDC  
 : 2.75 A @ 14VDC  
 : 1.58 A @ 24VDC
- Coil insulation . . . . . : Class H  
 (180°C - 356°F)
- Weather protection . . . . . : IP65 - ISO4400  
 : IP69K - Deutsch DT  
 : IP65 - AMP JPT
- Insertion . . . . . : 100%

**Flying leads**

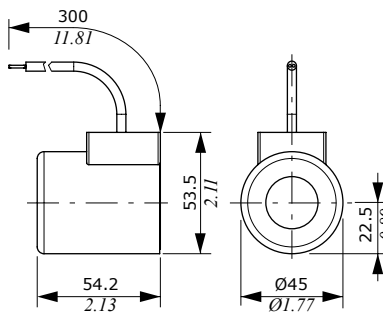

**AMP JPT connector**

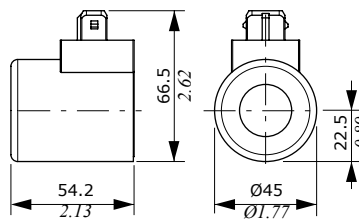



## Accessories

### Fixing brackets

#### SDE060

Dimensions (\*) are referred to directional valve with N1 type inlet section.

On valve for 60 l/min (15.8 US gpm) flow rate

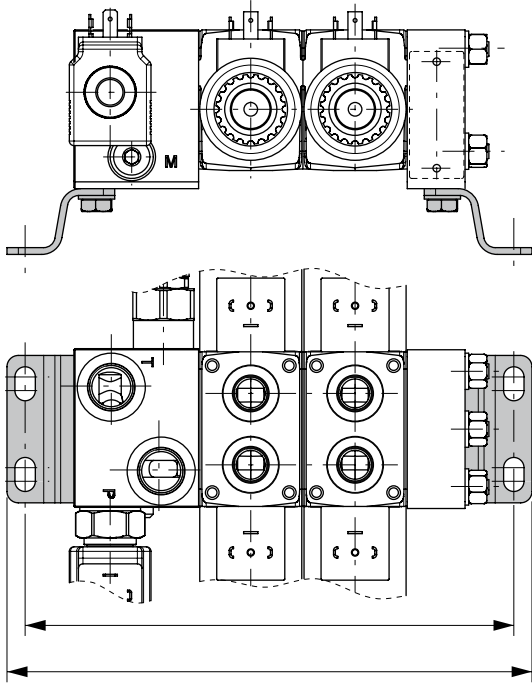

On valve for 30 l/min (7.9 US gpm) flow rate

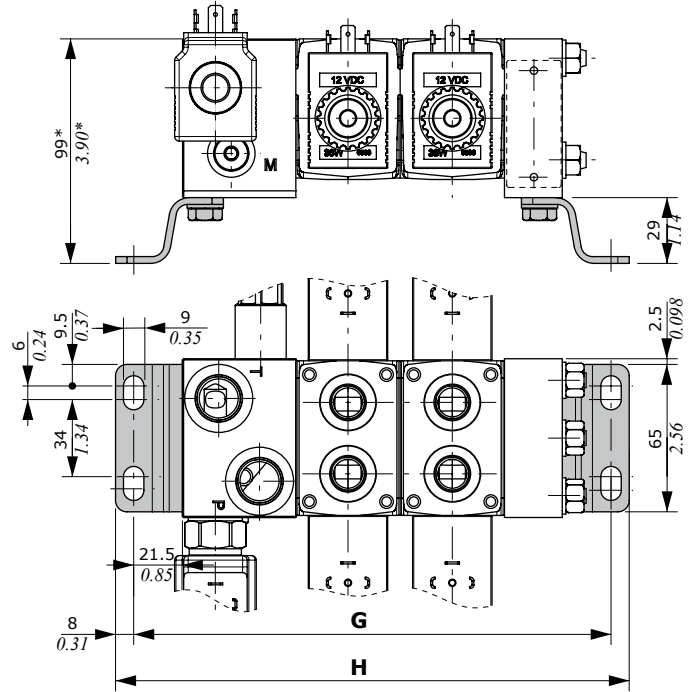

Valve for 60 l/min (15.8 US gpm) flow rate

TYPE	with section N type		with section N1 type		with section N2 type							
	G	H	G	H	G	H						
	mm	in	mm	in	mm	in						
SDE060/1	146.5	5.77	162.5	6.40	169.5	6.67	185.5	7.30	200	7.87	216	8.50
SDE060/2	192.5	7.58	208.5	8.21	215.5	8.48	231.5	9.11	246	9.69	262	10.31
SDE060/3	238.5	9.39	254.5	10.02	261.5	10.29	277.5	10.93	292	11.50	308	12.13
SDE060/4	284.5	11.20	300.5	11.83	307.5	12.11	323.5	12.74	338	13.31	354	13.94
SDE060/5	330.5	13.01	346.5	13.64	353.5	13.92	369.5	14.55	384	15.12	400	15.75
SDE060/6	376.5	14.82	392.5	15.45	399.5	15.73	415.5	16.36	430	16.93	446	17.56
SDE060/7	422.5	16.63	441.5	17.38	445.5	17.54	461.5	18.17	476	18.74	492	19.37
SDE060/8	468.5	18.44	484.5	19.07	491.5	19.35	507.5	19.98	522	20.55	538	21.18
SDE060/9	514.5	20.26	530.5	20.89	537.5	21.16	553.5	21.79	568	22.36	584	22.99
SDE060/10	560.5	22.07	575.5	22.66	583.5	22.97	599.5	23.60	614	24.17	630	24.80

Valve for 30 l/min (7.9 US gpm) flow rate

TYPE	with section NB type		with section N1B type		with section N2B type		with sections N6B-N7B type									
	G	H	G	H	G	H	G	H								
	mm	in	mm	in	mm	in	mm	in								
SDE060/1	146.5	5.77	162.5	6.40	162.5	6.40	178.5	7.03	191	7.52	207	8.15	183.5	7.22	199.5	7.85
SDE060/2	192.5	7.58	208.5	8.21	208.5	8.21	224.5	8.84	237	9.33	253	9.96	229.5	9.04	245.5	9.66
SDE060/3	238.5	9.39	254.5	10.02	254.5	10.02	270.5	10.65	283	11.14	299	11.77	275.5	10.85	291.5	11.48
SDE060/4	284.5	11.20	300.5	11.83	300.5	11.83	316.5	12.46	329	12.95	345	13.58	321.5	12.66	337.5	13.29
SDE060/5	330.5	13.01	346.5	13.64	346.5	13.64	362.5	14.27	375	14.76	391	15.39	367.5	14.47	383.5	15.10
SDE060/6	376.5	14.82	392.5	15.45	392.5	15.45	408.5	16.08	421	16.57	437	17.20	413.5	16.28	429.5	16.91
SDE060/7	422.5	16.63	441.5	17.38	438.5	17.26	454.5	17.89	467	18.39	483	19.02	459.5	18.09	475.5	18.72
SDE060/8	468.5	18.44	484.5	19.07	484.5	19.07	500.5	19.70	513	20.20	529	20.83	505.5	19.90	521.5	20.53
SDE060/9	514.5	20.26	530.5	20.89	530.5	20.89	546.5	21.52	559	22.01	575	22.64	551.5	21.71	567.5	22.34
SDE060/10	560.5	22.07	575.5	22.66	576.5	22.70	592.5	23.33	605	23.82	621	24.45	597.5	23.52	613.5	24.15

## Installation and maintenance

The SDE060-SDE030 valves are assembled and tested as per the technical specifications of this catalogue.

Before the final installation on your equipment, kindly follow the recommendations below:

- the valves can be assembled in any position; in order to prevent body deformation and spool sticking, mount the products on a flat surface;
- In order to prevent the possibility of water entering into the spool control kit, do not use high pressure wash down directly on the valves;
- Before painting, ensure plastic port plugs are tightly in their place.

### Fittings tightening torque (Nm-lbft)

SDE030			
THREAD TYPE	P-T ports	A-B ports	M-LS ports
BSP	G 3/8	G 3/8	G 1/4
With O-Ring seal	35 - 25.8	35 - 25.8	25 - 18.4
With copper washer	40 - 29.5	40 - 29.5	30 - 22
With steel and rubber washer	30 - 22	30 - 22	16 - 11.8
UN-UNF	3/4-16 (SAE 8)	9/16-18 (SAE 6)	7/16-20(SAE 4) 9/16-18 (SAE 6)**
With O-Ring seal	35 - 25.8	30 - 22	18-13.3 • 30**-22**

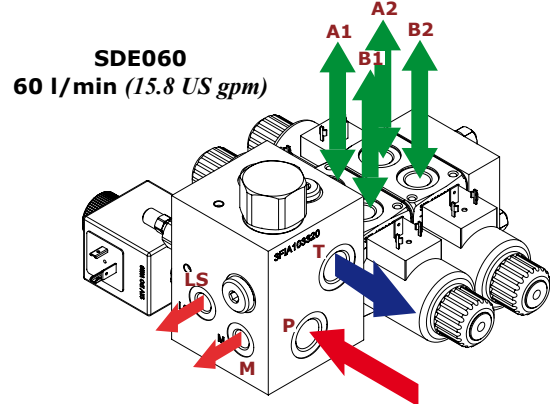
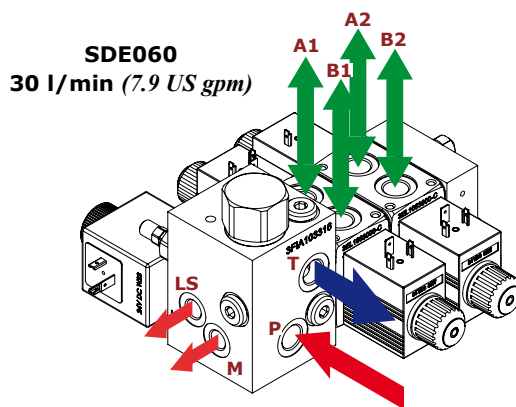
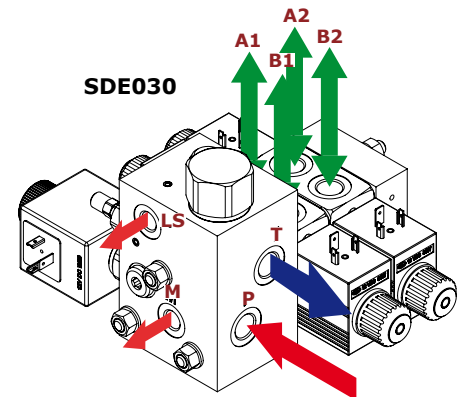

THREAD TYPE	Section for 30 l/min (7.9 US gpm)			Section for 60 l/min (15.8 US gpm)		
	P-T ports	A-B ports	M-LS ports	P-T ports	A-B ports	M-LS ports
BSP	G 3/8	G 3/8	G 1/4	G 1/2	G 3/8 • G 1/2*	G 1/4
With O-Ring seal	35 - 25.8	35 - 25.8	25 - 18.4	50 - 37	35-25.8 • 50*-37*	25 - 18.4
With copper washer	40 - 29.5	40 - 29.5	30 - 22	60 - 44.3	40-29.5 • 60*-44.3*	30 - 22
With steel and rubber washer	30 - 22	30 - 22	16 - 11.8	60 - 44.3	30-22 • 60*-44.3*	16 - 11.8
UN-UNF	3/4-16 (SAE 8)	9/16-18 (SAE 6)	7/16-20(SAE 4) 9/16-18 (SAE 6)**	3/4-16 (SAE 8)	9/16-18 (SAE 6) 3/4-16 (SAE 8)**	7/16-20 (SAE 4) 9/16-18 (SAE 6)**
With O-Ring seal	35 - 25.8	30 - 22	18-13.3 • 30**- 22**	35 - 25.8	30-22 • 35**- 25.8**	18-13.3 • 30**- 22**

NOTE – These torques are recommended. Assembly tightening torque depends on many factors, including lubrication, coating and surface finishing. The manufacturer must be consulted.

Malfunction	Cause	Remedy
External leakage from electric control	Control spool seal due to mechanical wear.	Replace the seal.
Excessive internal leakage on A and B ports.	Increase clearance between spools and body due to high wear.	Replace the directional control valve and check the oil contamination level.
Inability to build pressure on A and B	Main pressure relief valve blocked open.	Remove, clean or replace the main relief valve.
	Port relief valve open.	Remove, clean or replace the port relief valve.
	Low pump pressure and flow.	Check the pump and the circuit.



Innovation · Continuity · Integration  
————— It is Power —————

 **walvoil**  
FLUID POWER EMOTION



D1WWEB04A  
6<sup>th</sup> edition December 2017

Walvoil S.P.A. • 42124 Reggio Emilia • Italy • Via Adige, 13/D • Tel. +39.0522.932411 • Fax +39.0522.300984  
[www.walvoil.com](http://www.walvoil.com)

