

OEM REPLACEMENT 200 LBS OR 80 LBS DC VIBRATOR MOTOR

The new CNX vibrator motor from Canimex is built with high-quality materials and is totally sealed from outside elements including salt, sand, water, snow and dirt so that it can withstand extreme conditions.

FEATURES

- 200 lbs or 80 lbs vibration force
- Heavy duty vibrator motor for 200 lbs or 80 lbs spreaders with a nominal 12 volt DC power source
- Pressures decay tested
- ASTM B117 normalized standards salt spray tested



CLEVER DESIGN

- A** Low temperature, vibration proof harness, standards SAEJ928 moulded connector type installed. Delphi, AMP or custom sealed connectors available on request.
- B** Counterweight design, speed and motor adapted to match the customer vibration requirements. Canimex owns the equipment to control vibration parameters.
- C** Permanently greased and sealed bearings to avoid motor brush contamination.
- D** Vibration proof motor brush assembly.
- E** Cast aluminum housing with a protective coating and stainless steel fasteners.

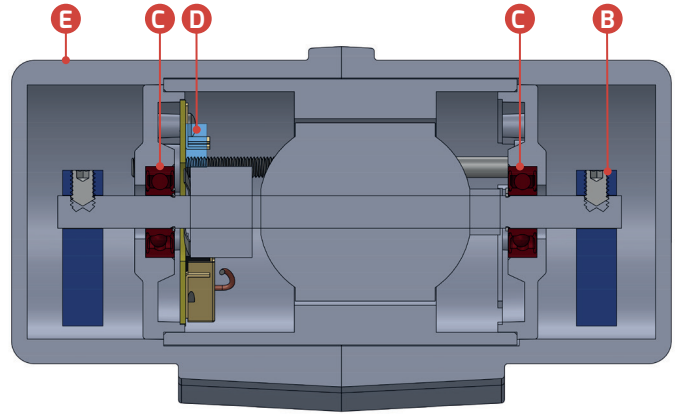

WORLD-CLASS OEM SOLUTIONS PROVIDER SINCE 1969

As an integrated company, we are much more than a supplier of components. We supply comprehensive and customized solutions, providing design, quality management, packaging, storage, handling, transportation and customs clearance services. In addition, our commitment to offering you the best service has been our hallmark since 1969.

- | | | |
|----------------------------------|-----------------------------|--|
| • One stop shop | • Design services | • Transportation and customs clearance services |
| • "Just in time" delivery | • Quality management | • Project development support from our engineering team |
| • Customized solutions | • Packaging | • Sub-assembly and welding services |



For more information, please contact:
Sales Department, Mechanical and Electrical Division | Canimex
mec@canimex.com

canimex.com |   

PUBMEC0081-EN