

ATTACCHI :

A - B - P - T = SAE 10

Portata massima : 60 L/min

Pressione massima = 210 Bar

Fluido = olio minerale 20-150 cSt

Filtraggio = 50 micron nominali

Temperatura ambiente = 0 ÷ 40 °C

Temperatura olio = 0 ÷ 90 °C

Guarnizioni : BUNA N

MATERIALE :

Corpo : Alluminio

Particolari interni. : Acciaio cmt. tmp. rettificati

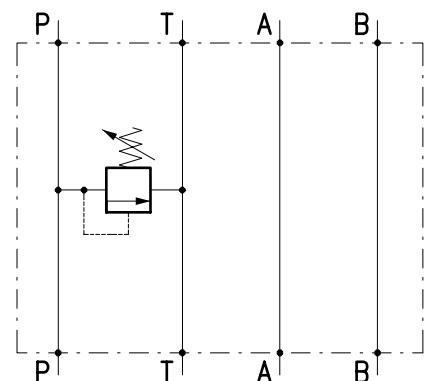

N° R.S.	Approvazione	Disegnatore	Data	I.R.
108/97		L.B.	30/9/97	2