



Hydraulic Valves (Parts in body)

TECHNICAL CATALOGUE



Additional information

This catalogue shows the product in the most standard configurations.
Please contact Sales Dpt. for more detailed information or special request.

WARNING!

All specifications of this catalogue refer to the standard product at this date.
Walvoil, oriented to a continuous improvement, reserves the right to
discontinue, modify or revise the specifications, without notice.



WALVOIL IS NOT RESPONSIBLE FOR ANY DAMAGE CAUSED BY AN
INCORRECT USE OF THE PRODUCT.

4th edition June 2019

Pressure control valves

Pressure relief valves								
Hydraulic diagram	Type	Execution	Operation/ Features	Max. flow up to		Max. press. up to		Page
				l/min	US gpm	bar	psi	
	VMD20 		direct acting	20	5.3	210 alum. body 350 steel body	3050 alum. body 5100 steel body	17
	VMP/B/L		direct acting	100	26.4	210 alum. body 350 steel body	3050 alum. body 5100 steel body	19
	VMPP/B/L		pilot operated	250	66	210 alum. body 350 steel body	3050 alum. body 5100 steel body	19
	VMDL..20 VMD..35 VMD..80 		direct acting	80	21.1	210 alum. body 350 steel body	3050 alum. body 5100 steel body	25
	VMPD/B	poppet	differential acting	180	47.6	210 alum. body 350 steel body	3050 alum. body 5100 steel body	29
	VMD150 		differential acting	150	39.6	210 alum. body	3050 alum. body	33
	VMDS150 		differential acting	150	39.6	350 steel body	5100 steel body	37
	VMP/VE		pilot operated, electric venting	250	66	210 alum. body 350 steel body	3050 alum. body 5100 steel body	41
	PBL		direct acting, subplate with VMP, CETOP flange connection	60	16	210 alum. body 350 steel body	3050 alum. body 5100 steel body	45
	VAIL		direct acting	120	31.7	210 alum. body 350 steel body	3050 alum. body 5100 steel body	49
	VADDL		differential acting, double antishock type	180	47.6	210 alum. body 350 steel body	3050 alum. body 5100 steel body	53
	VBDC35 VBDC80 		dual cross	80	21	210 alum. body 350 steel body	3050 alum. body 4350 steel body	57

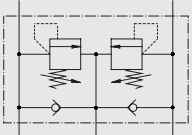
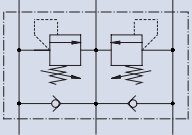
Pressure control valves

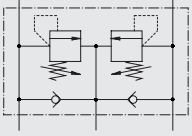
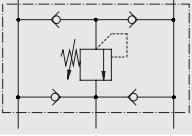
Pressure relief valves								
Hydraulic diagram	Type	Execution	Operation/ Features	Max. flow up to		Max. press. up to		Page
				l/min	US gpm	bar	psi	
	VAIL/VA		direct acting, double antishock and anticavitation type	80	21	210 alum. body 300 steel body	3050 alum. body 4350 steel body	61
	VMDACSV 		differential acting, double antishock and anticavitation type	70	18.5	350 steel body	5100 steel body	65
	VADDL/VA		differential acting, double antishock and anticavitation type	180	47.6	210 alum. body 350 steel body	3050 alum. body 5100 steel body	67
	VAA/RU/DL		direct acting, antishock and anticavitation type	180	47.6	210 alum. body 350 steel body	3050 alum. body 5100 steel body	71

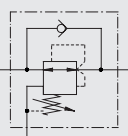
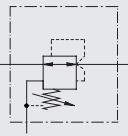
Pressure reducing valves								
Hydraulic diagram	Type	Execution	Operation/ Features	Max. flow up to		Max. press. up to		Page
				l/min	US gpm	bar	psi	
	VRPRL		with relieving and reverse free-flow check	50	13.2	210 alum. body 350 steel body	3050 alum. body 5100 steel body	75
	VRPRL/U		with relieving	50	13.2	210 alum. body 350 steel body	3050 alum. body 5100 steel body	75

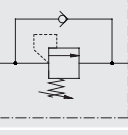
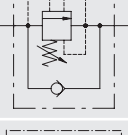
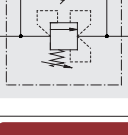





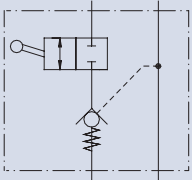

Sequence valves								
Hydraulic diagram	Type	Execution	Operation/ Features	Max. flow up to		Max. press. up to		Page
				l/min	US gpm	bar	psi	
	VDSRL		direct acting	120	31.7	210 alum. body 350 steel body	3050 alum. body 5100 steel body	79
	VDSRL/APP		direct acting, back-pressure proof	120	31.7	210 alum. body 350 steel body	3050 alum. body 5100 steel body	83
	VDSB/B		differential acting	200	52.8	210 alum. body 350 steel body	3050 alum. body 5100 steel body	87

Motion control valves

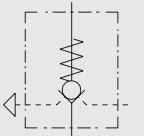
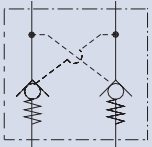
Check valves and shuttle valves								
Hydraulic diagram	Type	Execution	Operation / Features	Max. flow up to		Max. press. up to		Page
				l/min	US gpm	bar	psi	
	VUI	poppet type		160	42.3	400	5800	91
	VUS/INC	ball type		78	20.6	350	5100	95
	VUS/INC/A	poppet type		80	21.1	350	5100	97
	VUS/INC/B	poppet type		80	21.1	350	5100	99
	VUS	ball type		80	21.1	400	5800	101
	VUC	poppet type		380	100	400	5800	103
	VUC/M	poppet type		250	66	400	5800	105
	VT	ball type		180	47.6	350	5100	107
	VBD VBD/VP		double acting	90	23.8	350	5100	109
	VB		hose burst	225	59.4	350 steel body	5100 steel body	113

Pilot operated check valves								
Hydraulic diagram	Type	Execution	Operation / Features	Max. flow up to		Max. press. up to		Page
				l/min	US gpm	bar	psi	
	VUPSL		single acting	130	34.3	350 steel body	5100 steel body	117
	VBPSL		single acting	120	31.7	350 steel body	5100 steel body	119
	VRSE..A		single acting DIN2353	80	21.1	350 steel body	5100 steel body	123
	VRSE..CIL		single acting, bolt connection	20	5.3	300 steel body	4350 steel body	127
	VBPSL/T		single acting	100	26.4	210 alum. body 350 steel body	3050 alum. body 5100 steel body	129
	VBPSL/SO		single acting, bolt connection	50	13.2	210 alum. body	3050 alum. body	131
	VBPSF		single acting and face mounting	100	26.4	210 alum. body 350 steel body	3050 alum. body 5100 steel body	135

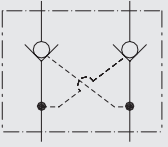
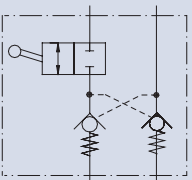
Motion control valves

Pilot operated check valves								
Hydraulic diagram	Type	Execution	Operation/ Features	Max. flow up to		Max. press. up to		Page
				l/min	US gpm	bar	psi	
	VBPSL/R 		single acting with shut-off	50	13.2	350 steel body	5100 steel body	139
	VRPSE..A.. 		single acting DIN2353 with shut-off	50	13.2	350 steel body	5100 steel body	141
	VBPSL/PS		external pilot operated type	35	9.2	210 alum. body 350 steel body	3050 alum. body 5100 steel body	143
	VBPDL 		double acting	120	31.7	350 steel body	5100 steel body	145
	VRDE..A 		double acting DIN2353	80	21.1	350 steel body	5100 steel body	149
	VRDE..CIL 		double acting bolt connection	20	5.3	300 steel body	4350 steel body	153
	VBPDL/T	double acting		100	26.4	210 alum. body 350 steel body	3050 alum. body 5100 steel body	155
	VBPDL/SO	double acting	bolt connection	50	13.2	210 alum. body 350 steel body	3050 alum. body 5100 steel body	157
	VBPDF	double acting	face mounting	100	26.4	210 alum. body 350 steel body	3050 alum. body 5100 steel body	161
	VBPDL/R 	double acting		50	13.2	350 steel body	5100 steel body	165
	VRPDE..A 	double acting	DIN2353 connection	50	13.2	350 steel body	5100 steel body	167

Motion control valves

Counterbalance valves								
Hydraulic diagram	Type	Execution	Operation/ Features	Max. flow up to		Max. press. up to		Page
				l/min	US gpm	bar	psi	
	VO SL/N78 VO SL/N78/PB	single acting	load sensitive	40	10.6	350 steel body	5100 steel body	169
	VO SLP/N78	single acting	external pilot	40	10.6	350 steel body	5100 steel body	173
	VO DL/N78 VO DL/N78/PB	double acting	load sensitive	40	10.6	350 steel body	5100 steel body	175
	VO SL/N1116 VO SL/N1116/PB	single acting	load sensitive	60	15.9	210 alum. body 350 steel body	3050 alum. body 5100 steel body	179
	VO SL/R1116	single acting	relief compensated	60	15.9	210 alum. body 350 steel body	3050 alum. body 5100 steel body	179
	VO SL/V1116	single acting	vented	60	15.9	210 alum. body 350 steel body	3050 alum. body 5100 steel body	179
	VO SLP/N1116	single acting	load sensitive with external pilot	60	15.9	210 alum. body 350 steel body	3050 alum. body 5100 steel body	189
	VO SLP/R1116	single acting	relief compensated with external pilot	60	15.9	210 alum. body 350 steel body	3050 alum. body 5100 steel body	189
	VO DL/N1116 VO DL/N1116/PB	double acting	load sensitive	60	15.9	210 alum. body 350 steel body	3050 alum. body 5100 steel body	197
	VO DL/R1116	double acting	relief compensated	60	15.9	210 alum. body 350 steel body	3050 alum. body 5100 steel body	197
	VO DL/V1116/CS	double acting	vented	60	15.9	350 steel body	5100 steel body	205

Motion control valves

Counterbalance valves								
Hydraulic diagram	Type	Execution	Operation/ Features	Max. flow up to		Max. press. up to		Page
				l/min	US gpm	bar	psi	
	VOSL/N1516	single acting	load sensitive	160	42.3	400 steel body	5800 steel body	209
	VOSL/V1516	single acting	vented	160	42.3	400 steel body	5800 steel body	209
	VODL/N1516/CS	double acting	load sensitive	160	42.3	400 steel body	5800 steel body	217
	VODL/V1516/CS	double acting	vented	160	42.3	400 steel body	5800 steel body	217
	VOSL	single acting	load sensitive	180	47.6	210 alum. body 350 steel body	3050 alum. body 5100 steel body	225
	VOSL/CC	single acting	relief compensated	180	47.6	210 alum. body 350 steel body	3050 alum. body 5100 steel body	229
	VOSL/SC	single acting		180	47.6	210 alum. body 350 steel body	3050 alum. body 5100 steel body	233
	VOSL/SC/CC	single acting		180	47.6	210 alum. body 350 steel body	3050 alum. body 5100 steel body	237
	VOSLP	single acting	with external pilot	180	47.6	210 alum. body 350 steel body	3050 alum. body 5100 steel body	241
	VOSLP/CC	single acting	relief compensated, with external pilot	180	47.6	210 alum. body 350 steel body	3050 alum. body 5100 steel body	245
	VOSLP/SC	single acting	load sensitive, with external pilot	180	47.6	210 alum. body 350 steel body	3050 alum. body 5100 steel body	249
	VOSLP/SC/RO	single acting	load sensitive, with external pilot, bolt connection	180	47.6	210 alum. body 350 steel body	3050 alum. body 5100 steel body	253

Motion control valves

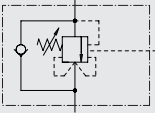
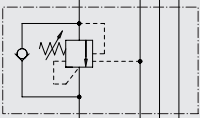
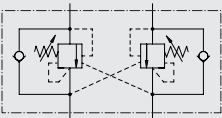
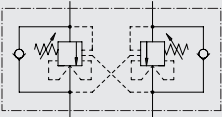
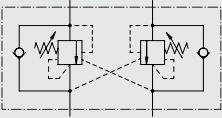
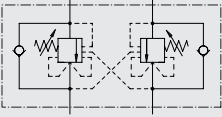
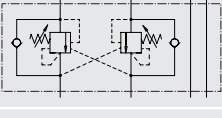
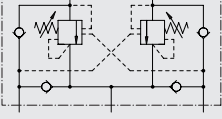
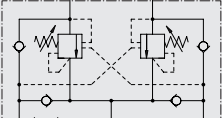
Counterbalance valves								
Hydraulic diagram	Type	Execution	Operation/ Features	Max. flow up to		Max. press. up to		Page
				l/min	US gpm	bar	psi	
	VOSLP/SC/CC	single acting	relief compensated, with external pilot	180	47.6	210 alum. body 350 steel body	3050 alum. body 5100 steel body	257
	VOSL/ML	single acting	load sensitive, CETOP flange connection	70	18.5	210 alum. body 350 steel body	3050 alum. body 5100 steel body	261
	VODL	double acting	load sensitive	180	47.6	210 alum. body 350 steel body	3050 alum. body 5100 steel body	265
	VODL/CC	double acting	relief compensated	180	47.6	210 alum. body 350 steel body	3050 alum. body 5100 steel body	269
	VODL/SC	double acting	load sensitive	180	47.6	210 alum. body 350 steel body	3050 alum. body 5100 steel body	273
	VODL/SC/CC	double acting	relief compensated	180	47.6	210 alum. body 350 steel body	3050 alum. body 5100 steel body	277
	VODL/ML	double acting	load sensitive, CETOP flange connection	70	18.5	210 alum. body 350 steel body	3050 alum. body 5100 steel body	281
	VABAL	double acting	load sensitive, relief valve for motion control	180	47.5	210 alum. body 350 steel body	3050 alum. body 5100 steel body	285
	VABAL/SF	double acting	load sensitive, relief valve for motion control	180	47.6	210 alum. body 350 steel body	3050 alum. body 5100 steel body	289

Flow control valves

Needle valves								
Hydraulic diagram	Type	Execution	Operation/ Features	Max. flow up to		Max. press. up to		Page
				l/min	US gpm	bar	psi	
	VSRU 	ball or poppet type	with check valve	280	74	350 steel body	5100 steel body	293
	VSRB 		bidirectional	150	39.6	350 steel body	5100 steel body	299
	VRFB90 	2 way	bidirectional	110	29.1	350 steel body	5100 steel body	301
	VRFU90 	2 way	with check valve	180	47.6	350 steel body	5100 steel body	303

Flow control pressure compensated valves								
Hydraulic diagram	Type	Execution	Operation/ Features	Max. flow up to		Max. press. up to		Page
				l/min	US gpm	bar	psi	
	VPR/2/RL	2 way	reverse free-flow check	150	39.6	210 alum. body 350 steel body	3050 alum. body 5100 steel body	307
	VPR/2/RL/EX 	2 way	compensated, with check valve	45	11.9	300 steel body	4350 steel body	311
	VPR/2/U	2 way	variable constant flow	150	39.6	210 alum. body 350 steel body	3050 alum. body 5100 steel body	313
	VPF/3/EP	3 way	exceeding flow to pressure, with constant flow in "C"	150	39.6	210 alum. body 350 steel body	3050 alum. body 5100 steel body	317
	VPF/3/EP+VMP	3 way	exceeding flow to pressure, with pressure relief valve	150	39.6	210 alum. body 350 steel body	3050 alum. body 5100 steel body	321
	VPR/3/ET	3 way		350	92.5	210 alum. body 350 steel body	3050 alum. body 5100 steel body	325
	VPR/3/ET/RL	3 way	with reverse free-flow check	150	39.6	210 alum. body 350 steel body	3050 alum. body 5100 steel body	329
	VPR/3/ET/VMP	3 way	with pressure relief valve	350	92.5	210 alum. body 350 steel body	3050 alum. body 5100 steel body	333

Flow control pressure compensated valves								
Hydraulic diagram	Type	Execution	Operation/ Features	Max. flow up to		Max. press. up to		Page
				l/min	US gpm	bar	psi	
	VPR/3/ET/RL/VMP	3 way	with reverse free-flow check and pressure relief valve	150	39.6	210 alum. body 350 steel body	3050 alum. body 5100 steel body	337
	VPR/3/ET VMP+VE	3 way	electric venting	240	63.4	210 alum. body 350 steel body	3050 alum. body 5100 steel body	341
	VPR/3/EP	3 way	exceeding flow to pressure	450	119	210 alum. body 350 steel body	3050 alum. body 5100 steel body	347
	VPR/3/EP/VMP+VE	3 way	exceeding flow to pressure, with pressure relief valve and electric venting	450	119	210 alum. body 350 steel body	3050 alum. body 5100 steel body	353
	VPR/3/EP/VMP+VE/LPD	3 way	exceeding flow to pressure, with pressure relief valve and electric venting, low pressure drop	450	119	350 steel body	5100 steel body	359
	VDR 	cartridge	adjustable type	220	58.1	350 steel body	5100 steel body	363
	VDR/CO 	cartridge	fixed type	60	15.9	350 steel body	5100 steel body	367
	VSCOR 	pop-in cartridge	fixed type	25	6.6	350 steel body	5100 steel body	371
	VDFR		flow divider combiners	250	66	210 alum. body 350 steel body	3050 alum. body 5100 steel body	373

Directional solenoid valves

Directional solenoid valves								
Hydraulic diagram	Type	Execution	Operation/ Features	Max. flow up to		Max. press. up to		Page
				l/min	US gpm	bar	psi	
	VE/B	2 way	pilot operated with emergency	160	42.3	210 alum. body 350 steel body	3050 alum. body 5100 steel body	377
	VE/B/RO		pilot operated with emergency, bolt connection	40	10.6	210 alum. body 350 steel body	3050 alum. body 5100 steel body	381
	VE/B/VMP/VUI/SR		block for single acting cylinder	150	39.6	210 alum. body 350 steel body	3050 alum. body 5100 steel body	385

Logic valves

Stroke end valves								
Hydraulic diagram	Type	Execution	Operation/ Features	Max. flow up to		Max. press. up to		Page
				l/min	US gpm	bar	psi	
	FCS..C FC..C 	double lock	normally closed	60	15.9	300 steel body	4350 steel body	389
	FC..A 		normally open	60	15.9	300 steel body	4350 steel body	391

Unloader valves								
Hydraulic diagram	Type	Execution	Operation/ Features	Max. flow up to		Max. press. up to		Page
				l/min	US gpm	bar	psi	
	VDA		single acting	100	26.5	210 alum. body 350 steel body	3050 alum. body 5100 steel body	393
	VDA/FL		face mounting	50	13.2	210 alum. body 350 steel body	3050 alum. body 5100 steel body	397

Regenerative valves

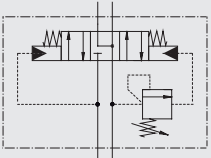
Hydraulic diagram	Type	Execution	Operation/ Features	Max. flow up to		Max. press. up to		Page
				l/min	US gpm	bar	psi	
	VRCL/KD		regenerative	150	39.6	350 steel body	5100 steel body	401



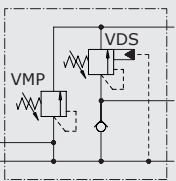
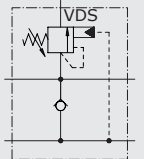
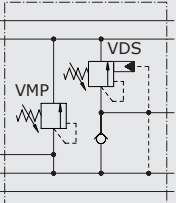



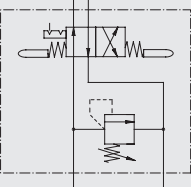
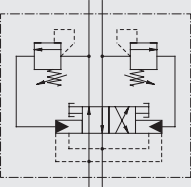
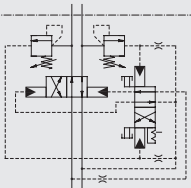
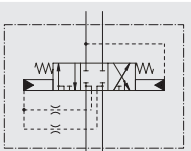

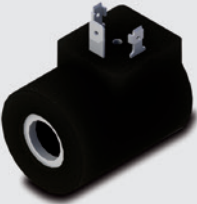

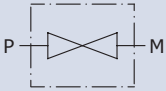
Two pump "hi low" unloading-valves

Hydraulic diagram	Type	Execution	Operation/ Features	Max. flow up to		Max. press. up to		Page
				l/min	US gpm	bar	psi	
	VEP		single acting	250	66	210 alum. body 350 steel body	3050 alum. body 5100 steel body	405
	VEP/FC		face mounting on gear pump	180	47.6	210 alum. body 350 steel body	3050 alum. body 5100 steel body	409
	VEP/FL		cetop base 3-5-7	100	26.5	210 alum. body 350 steel body	3050 alum. body 5100 steel body	413

Logic valves

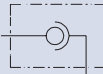
Automatic reversing valves								
Hydraulic diagram	Type	Execution	Operation/Features	Max. flow up to		Max. press. up to		Page
				l/min	US gpm	bar	psi	
	SD.../IAM		mechanical control	65	17.2	210 cast iron body	3050 cast iron body	419
	VIA/AP		CETOP flange connection	60	15.9	210 cast iron body	3050 cast iron body	423
	VIA/AP 12/L/CMEB		mechanical and hydraulic control	60	15.9	210 cast iron body	3050 cast iron body	427
	VIA/DSL		CETOP flange connection	60	15.9	210 cast iron body	3050 cast iron body	431

Coils							
Diagram	Type	Description	Nominal power rating		Available nominal voltage		Page
			W		VDC	RAC	
	BER	coil	19		10 - 12 14 - 24 28 - 48 110 - 220	24 - 48 110 - 220	433
	BT	coil	21		10 - 12 24 - 26 48 - 110 220	24 - 48 110 - 220	433

Coupling & adapters							
Diagram	Type	Description	Max. flow up to		Max. press. up to		Page
			l/min	US gpm	bar	psi	
	EMIL EM90 	gauge isolator	5	1.3	350 brass body	5100 brass body	436
	VTS 	throttle valve	30	7.9	350 steel body	5100 steel body	437
	GGIL 	rotary coupling	300	79.3	400 steel body	5800 steel body	438
	GG90 						
	OCC VT RON 	fittings for DIN2353 valves	/	/	350 steel body	5100 steel body	439

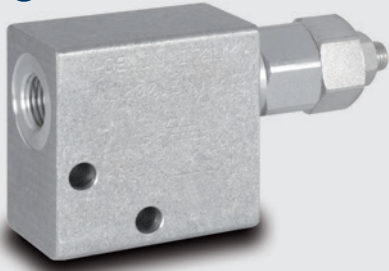

Type VMD..20 pressure relief valves

- Direct acting

Technical specifications and diagrams are measured with mineral oil of 46 cSt viscosity at 40°C (104°F) temperature.

	VMD..2001	VMD..2002
Nominal flow	20 l/min (5.3 US gpm)	20 l/min (5.3 US gpm)
Max. pressure	Aluminium body = 210 bar (3050 psi) Steel body = 350 bar (5100 psi)	
Fluid	mineral based oil	
Viscosity	from 10 to 200 cSt	
Max. level of contamination	18/16/13 ISO4406	
Fluid temperature	with NBR seals from -20°C (-4°F) to 80°C (176°F)	
Environmental temp.for working conditions	from -40°C (-40°F) to 100°C (212°F)	
Weight	aluminium	0.30 kg (0.66 lb)
	steel	0.61 kg (1.34 lb)
		0.28 kg (0.62 lb)
		0.59 kg (1.30 lb)

NOTE - For different conditions, please contact Walvoil Sales Dpt.

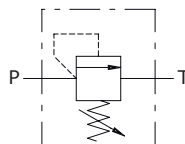

Dimensions

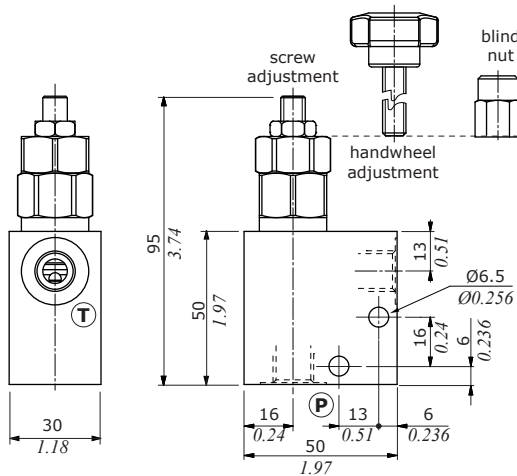

Dimensions are in mm-in

Valve type	All ports
VMD..20 01	G1/4
VMD..20 02	G3/8

Ordering codes and description composition

Port size: **VMD..20 01**
- aluminium
S = steel

Setting range: **B 1**
Adjustment option:
1 = screw type
2 = handwheel type
3 = blind nut

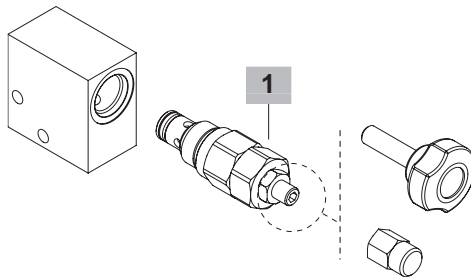

Spring type	Setting range bar (psi)	Std. setting bar (psi)
A	5-60 (72.5-870)	40 (580)
B	50-240 (725-3500)	100 (1450)
C	90-350 (130-5100)	100 (1450)
D	20-130 (290-1900)	100 (1450)

VMD..20 complete valves

TYPE	CODE	DESCRIPTION
Configuration with G1/4 standard thread		
VMD2001B1	1110611100	Aluminium body, setting range from 50 to 240 bar (725-3500 psi), std setting 100 bar @ 5 l/min (1450 psi @ 1.32 US gpm)
VMDS2001B1	1110612100	Steel body, as previous
Configuration with G3/8 standard thread		
VMD2002B1	1110621100	Aluminium body, setting range from 50 to 240 bar (725-3500 psi), std setting 100 bar @ 5 l/min (1450 psi @ 1.32 US gpm)
VMDS2002B1	1110622100	Steel body, as previous

For different configurations and SAE thread please contact our Sales Dpt.

1 Direct acting pressure relief valves

TYPE	CODE	DESCRIPTION
MC08F/0G2B	0MC08002069	Screw adjustment, setting range from 50 to 240 bar (725-3500 psi)

Rating diagrams

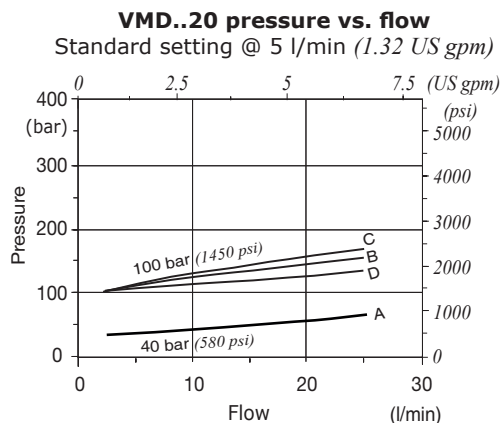

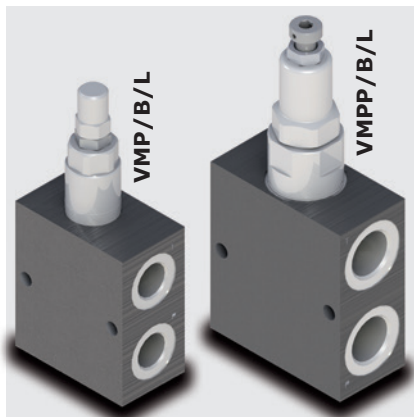

Type VMP/B/L - VMPP/B/L pressure relief valves

- Direct acting
- Piloted operated

Technical specifications and diagrams are measured with mineral oil of 46 cSt viscosity at 40°C (104°F) temperature.

	VMP/B/L						VMPP/B/L			
	02-14	03-14	5-38 5-12	5Y-38	10-12 10-34	20-34 20-100	10-12	20-34 20-100	45-114	
Nominal flow	5 l/min (1.3 US gpm)	10 l/min (2.6 US gpm)	35 l/min (9.2 US gpm)	35 l/min (9.2 US gpm)	60 l/min (16 US gpm)	100 l/min (26.4 US gpm)	70 l/min (18.5 US gpm)	120 l/min (31.7 US gpm)	250 l/min (66 US gpm)	
Max. pressure	Aluminium body = 210 bar (3050 psi) Steel body = 350 bar (5100 psi)									
Oil leakage at 80% of max. setting	5 cm ³ /min (0.30 in ³ /min)	5 cm ³ /min (0.30 in ³ /min)	3 cm ³ /min (0.18 in ³ /min)	1 cm ³ /min (0.06 in ³ /min)	3 cm ³ /min (0.18 in ³ /min)	3 cm ³ /min (0.18 in ³ /min)	20 cm ³ /min (1.22 in ³ /min)	25 cm ³ /min (1.52 in ³ /min)	40 cm ³ /min (2.44 in ³ /min)	
Fluid	mineral based oil									
Viscosity	from 10 to 200 cSt									
Max. level of contamination	18/16/13 ISO4406									
Fluid temp.	with NBR seals from -20°C (-4°F) to 80°C (176°F)									
Environmental temp. for wor- king conditions	from -40°C (-40°F) to 100°C (212°F)									
Weight	alum.	0.21 kg (0.46 lb)	0.40 kg (0.88 lb)	38: 0.48 kg (1.06 lb) 12: 0.46 kg (1.01 lb)	0.47 kg (1.04 lb)	12: 0.66 kg (1.46 lb) 34: 0.76 kg (1.68 lb)	34: 1.18 kg (2.60 lb) 100: 1.77 kg (3.90 lb)	0.66 kg (1.46 lb)	34: 1.27 kg (2.80 lb) 100: 1.85 kg (4.08 lb)	2.73 kg (6.02 lb)
		steel	0.99 kg (2.18 lb)	0.85 kg (1.87 lb)	38: 1.08 kg (2.38 lb) 12: 0.99 kg (2.18 lb)		12: 1.40 kg (3.09 lb) 34: 1.67 kg (3.68 lb)	34: 2.52 kg (5.56 lb) 100: 4.08 kg (8.99 lb)	1.39 kg (3.06 lb)	34: 2.60 kg (5.73 lb) 100: 4.16 kg (9.17 lb)

NOTE - For different conditions, please contact Walvoil Sales Dpt.

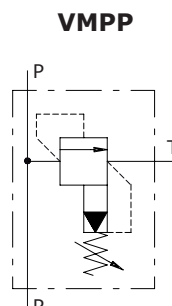
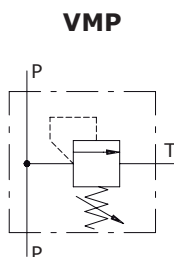

Dimensions

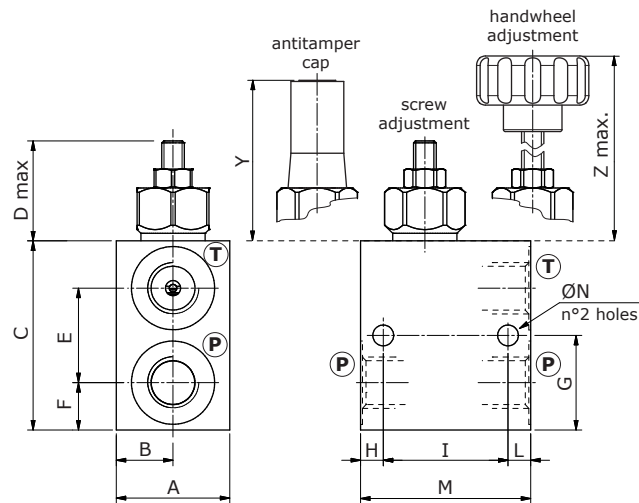

Valve type	All ports
VMP/B/L 02-14	G1/4
VMP/B/L 03-14	G1/4
Valve type	All ports
VMP/B/L 02-14/SAE	SAE6
VMP/B/L 03-14/SAE	SAE6

Dimensions are in mm-in

Valve type	A	B	C	D max	E	F	G	H-L	I	M	ØN	Y	ØK	Z max
VMP/B/L 02-14	30-1.18	15-0.59	50-1.97	29-1.14	25-0.98	12.5-0.49	25-0.98	6-0.24	33-1.30	45-1.77	5.5-0.22	42.5-1.67	30-1.18	49-1.93
VMP/B/L 03-14	30-1.18	15-0.59	60-2.36	53-2.09	32-1.26	14-0.55	30-1.18	6-0.24	48-1.89	60-2.98	6.5-0.25	52-2.05	40-1.57	86.5-3.41

Valve type	All ports
VMP/B/L 5-38	G3/8
VMP/B/L 5-12	G1/2
VMP/B/L 5Y-38	G3/8
VMP/B/L 5Y-12	G1/2
Valve type	All ports
VMP/B/L 5-38/SAE	SAE8
VMP/B/L 5-12/SAE	SAE10
VMP/B/L 5Y-38/SAE	SAE8
VMP/B/L 5Y-12/SAE	SAE10

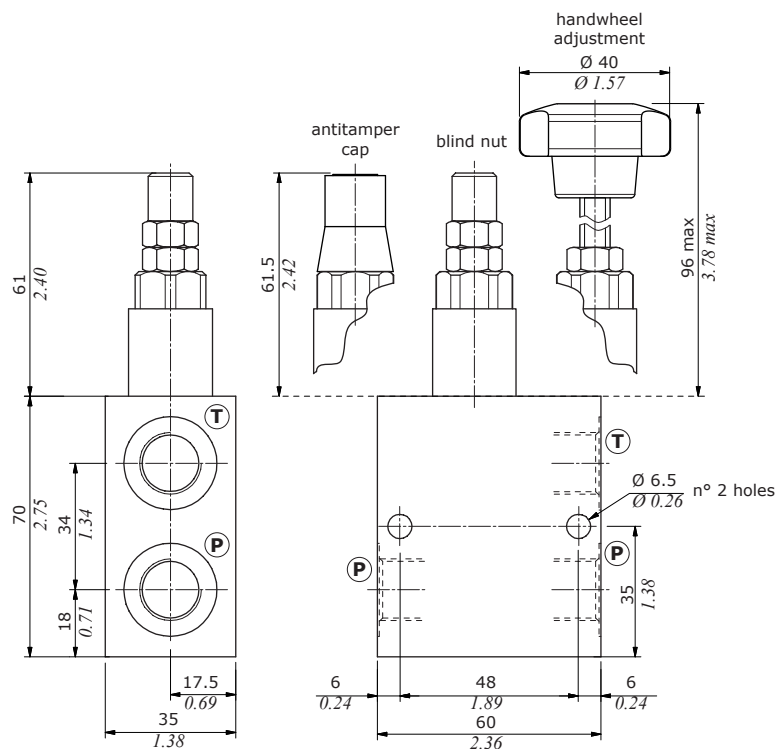

Ordering codes

Valve type	All ports	Valve type	All ports
VMP/B/L 10-12	G1/2	VMP/B/L 10-12/SAE	SAE10
VMP/B/L 10-34	G3/4	VMP/B/L 10-34/SAE	SAE12
VMP/B/L 20-34	G3/4	VMP/B/L 20-34/SAE	SAE12
VMP/B/L 20-100	G1"	VMP/B/L 20-100/SAE	SAE16

Dimensions are in mm-in

Valve type	A	B	C	D	E	E
VMP/B/L 10-12	35-1.38	17.5-0.69	78-3.07	67-2.64	40-2.28	40-2.28
VMP/B/L 10-12/SAE	35-1.38	17.5-0.69	78-3.07	67-2.64	40-2.28	40-2.28
VMP/B/L 10-34	40-1.57	20-0.79	90-3.54	67-2.64	50-1.97	50-1.97
VMP/B/L 10-34/SAE	40-1.57	20-0.79	90-3.54	67-2.64	50-1.97	50-1.97
VMP/B/L 20-34	50-1.97	25-0.98	100-3.94	76.5-3.01	57-2.24	57-2.24
VMP/B/L 20-34/SAE	50-1.97	25-0.98	100-3.94	76.5-3.01	57-2.24	57-2.24
VMP/B/L 20-100	60-3.34	30-1.18	120-4.72	76.5-3.01	65-2.56	65-2.56
VMP/B/L 20-100/SAE	60-3.34	30-1.18	120-4.72	76.5-3.01	65-2.56	65-2.56

F	G	H	I	L	ØN	ØK	Y	Z max
20-0.79	39-1.53	6-0.24	70-2.75	58-2.28	6.5-0.25	40-1.57	64.7-2.55	98-3.59
20-0.79	45-1.77	8-0.31	70-2.75	54-2.12	8.5-0.33	40-1.57	64.7-2.55	98-3.59
22-0.87	50-1.97	8-0.31	70-2.75	54-2.12	8.5-0.33	40-1.57	74-2.91	89.5-3.52
30-1.18	63-2.48	10-0.39	85-3.34	65-2.56	8.5-0.33	40-1.57	74-2.91	89.5-3.52

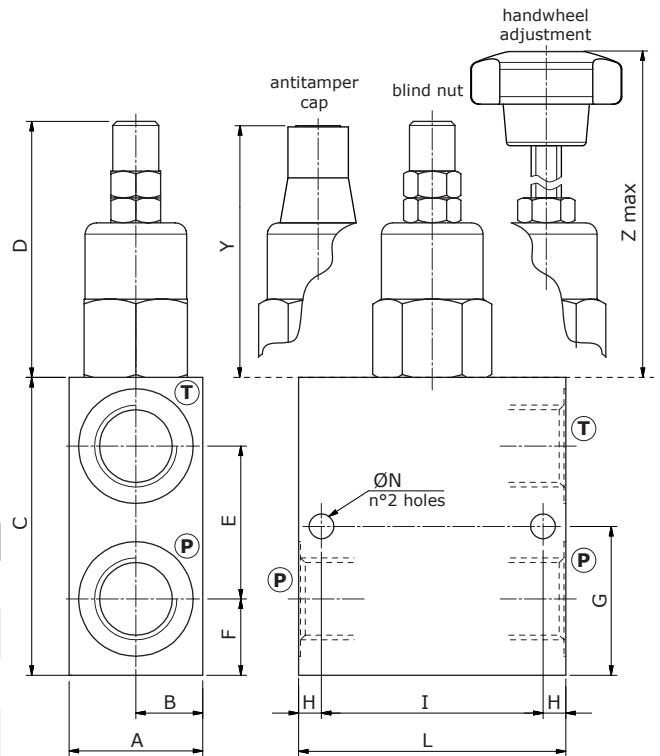

Valve type	All ports	Valve type	All ports
VMPP/B/L 10-12	G1/2	VMPP/B/L 10-12/SAE	SAE10
VMPP/B/L 20-34	G3/4	VMPP/B/L 20-34/SAE	SAE12
VMPP/B/L 20-100	G1"	VMPP/B/L 20-100/SAE	SAE16
VMPP/B/L 45-114	G1"1/4	VMPP/B/L 45-114/SAE	SAE20

Dimensions are in mm-in

Valve type	A	B	C	D max	E	F
VMPP/B/L 10-12	35-1.38	78-3.07	17.5-0.69	74.3-2.96	39-1.53	6-0.24
VMPP/B/L 10-12/SAE	35-1.38	78-3.07	17.5-0.69	74.3-2.96	39-1.53	6-0.24
VMPP/B/L 20-34	50-1.97	100-3.94	25-0.98	77.5-3.05	50-1.97	8-0.31
VMPP/B/L 20-34/SAE	50-1.97	100-3.94	25-0.98	77.5-3.05	50-1.97	8-0.31
VMPP/B/L 20-100	60-2.36	120-4.72	30-1.18	77.5-3.05	63-2.48	10-0.39
VMPP/B/L 20-100/SAE	60-2.36	120-4.72	30-1.18	77.5-3.05	63-2.48	10-0.39
VMPP/B/L 45-114	70-2.75	135-5.31	35-1.38	94.5-3.72	70-2.75	10-0.39
VMPP/B/L 45-114/SAE	70-2.75	135-5.31	35-1.38	94.5-3.72	70-2.75	10-0.39

G	H	I	L	ØN	Y	ØK	Z max
70-2.75	58-2.28	20-0.79	40-1.57	6.5-0.25	25.5-1	40-1.57	56-2.2
70-2.75	54-2.12	22-0.87	57-2.44	8.5-0.33	25.5-1	40-1.57	56-2.2
85-3.34	65-2.56	30-1.18	65-2.56	8.5-0.33	25.5-1	40-1.57	56-2.2
100-3.94	80-3.15	35-1.38	68-2.68	10.5-0.41	28-1.10	40-1.57	56-2.20

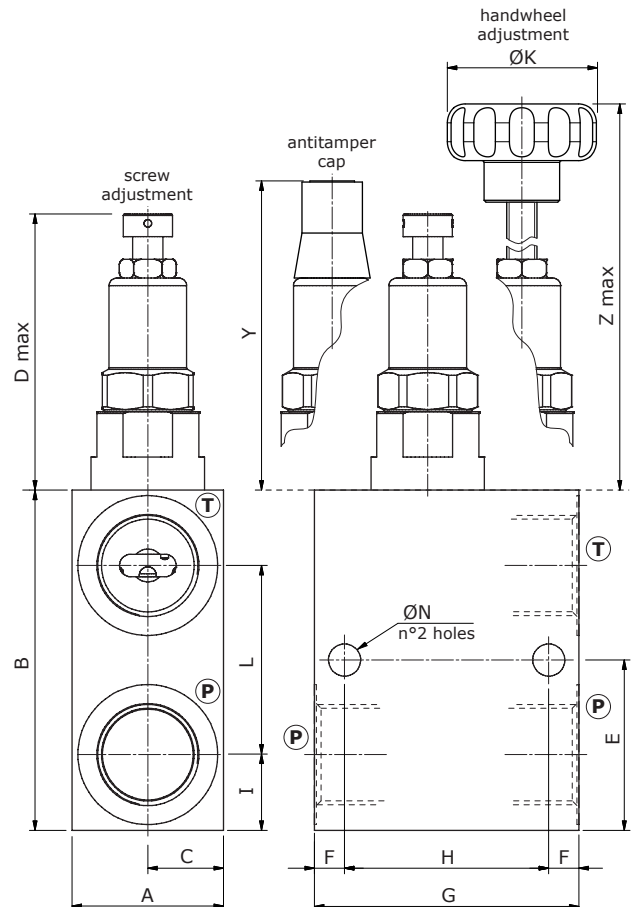

Ordering codes and description composition

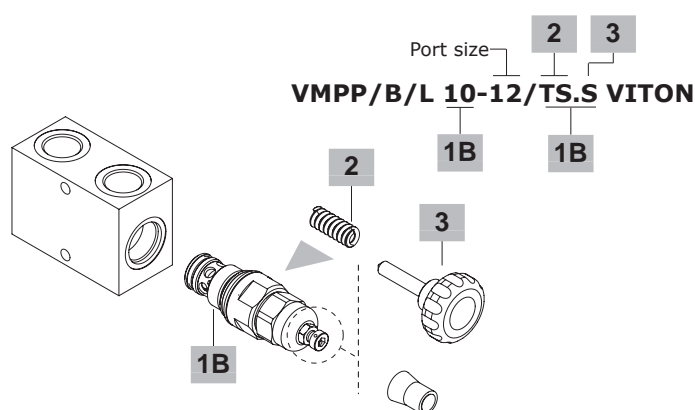
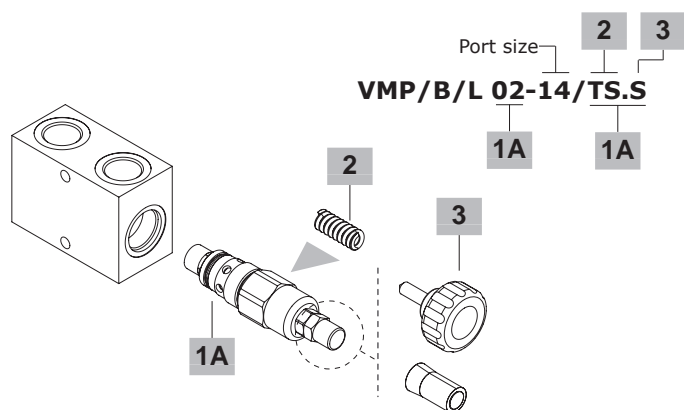

VMP/B/L complete direct acting valves

TYPE	CODE	DESCRIPTION
Configuration with G1/4 standard thread		
<i>Standard setting 150 bar @ 3 l/min (2175 psi @ 0.79 US gpm)</i>		
VMP/B/L 02-14/TS.G	1111001104	Aluminium body, range 50-220 bar (725-3200 psi)
VMP/B/L 02-14/TS.G/ac	1111002103	Steel body, as previous one
VMP/B/L 03-14/TS.S	1111011104	Aluminium body, range 50-200 bar (725-3200 psi)
VMP/B/L 03-14/TS.S/ac	1111012101	Steel body, as previous one
Configuration with G3/8 standard thread		
<i>Standard setting 160 bar @ 5 l/min (2320 psi @ 1.32 US gpm)</i>		
VMP/B/L 5-38/TS.S	1111021104	Aluminium body, range 50-220 bar (725-3200 psi)
VMP/B/L 5-38/TS.S/ac	1111022101	Steel body, as previous one
VMP/B/L 5Y-38/TS.S	1111021116	Aluminium body, range 50-220 bar (725-3200 psi)
Configuration with G1/2 standard thread		
<i>Standard setting 160 bar @ 5 l/min (2320 psi @ 1.32 US gpm)</i>		
VMP/B/L 5-12/TS.S	1111021154	Aluminium body, range 50-220 bar (725-3200 psi)
VMP/B/L 5-12/TS.S/ac	1111022150	Steel body, as previous one
VMP/B/L 10-12/TS.S	1111031104	Aluminium body, range 50-220 bar (725-3200 psi)
VMP/B/L 10-12/TS.S/ac	1111032100	Steel body, as previous one
Configuration with G3/4 standard thread		
<i>Standard setting 160 bar @ 5 l/min (2320 psi @ 1.32 US gpm)</i>		
VMP/B/L 10-34/TS.S	1111031154	Aluminium body, range 50-220 bar (725-3200 psi)
VMP/B/L 10-34/TS.S/ac	1111032151	Steel body, as previous one
VMP/B/L 20-34/TS.S	1111041104	Aluminium body, range 50-220 bar (725-3200 psi)
VMP/B/L 20-34/TS.S/ac	1111042102	Steel body, as previous one
Configuration with G1" standard thread		
<i>Standard setting 160 bar @ 5 l/min (2320 psi @ 1.32 US gpm)</i>		
VMP/B/L 20-100/TS.S	1111041154	Aluminium body, range 50-220 bar (725-3200 psi)
VMP/B/L 20-100/TS.S/ac	1111042150	Steel body, as previous one
Configuration with SAE6 standard thread		
<i>Standard setting 150 bar @ 3 l/min (2175 psi @ 0.79 US gpm)</i>		
VMP/B/L 02-14/TS.G/SAE	1111001201	Aluminium body, range 50-220 bar (725-3200 psi)
VMP/B/L 03-14/TS.S/SAE	1111011200	Aluminium body, range 50-200 bar (725-3200 psi)
Configuration with SAE8 standard thread		
<i>Standard setting 160 bar @ 5 l/min (2320 psi @ 1.32 US gpm)</i>		
VMP/B/L 5-38/TS.S/SAE	1111021200	Aluminium body, range 50-220 bar (725-3200 psi)
Configuration with SAE10 standard thread		
<i>Standard setting 160 bar @ 5 l/min (2320 psi @ 1.32 US gpm)</i>		
VMP/B/L 5-12/TS.S/SAE	1111021250	Aluminium body, range 50-220 bar (725-3200 psi)
VMP/B/L 10-12/TS.S/SAE	1111031200	Aluminium body, range 50-220 bar (725-3200 psi)

VMP/B/L complete direct acting valves (cont.)

Configuration with SAE12 standard thread		
<i>Standard setting 160 bar @ 5 l/min (2320 psi @ 1.32 US gpm)</i>		
VMP/B/L 10-34/TS.S/SAE	1111031250	Aluminium body, range 50-220 bar (725-3200 psi)
VMP/B/L 20-34/TS.S/SAE	1111041200	Aluminium body, range 50-220 bar (725-3200 psi)
Configuration with SAE16 standard thread		
<i>Standard setting 160 bar @ 5 l/min (2320 psi @ 1.32 US gpm)</i>		
VMP/B/L 20-100/TS.S/SAE	1111041250	Aluminium body, range 50-220 bar (725-3200 psi)

VMPP/B/L complete pilot operated valves

Configuration with G1/2 standard thread		
<i>Standard setting 120 bar @ 10 l/min (1740 psi @ 2.64 US gpm)</i>		
TYPE: VMPP/B/L 10-12/TS.W VITON	CODE: 1132031100	DESCRIPTION: Aluminium body, range 20-400 bar (290-5800 psi)
TYPE: VMPP/B/L 10-12/TS.W/ac VITON	CODE: 1132032100	DESCRIPTION: Steel body, as previous one
Configuration with G3/4 standard thread		
<i>Standard setting 120 bar @ 10 l/min (1740 psi @ 2.64 US gpm)</i>		
TYPE: VMPP/B/L 20-34/TS.W VITON	CODE: 1132041100	DESCRIPTION: Aluminium body, range 20-400 bar (290-5800 psi)
TYPE: VMPP/B/L 20-34/TS.W/ac VITON	CODE: 1132042100	DESCRIPTION: Steel body, as previous one
Configuration with G1" standard thread		
<i>Standard setting 120 bar @ 10 l/min (1740 psi @ 2.64 US gpm)</i>		
TYPE: VMPP/B/L 20-100/TS.W VITON	CODE: 1132041150	DESCRIPTION: Aluminium body, range 20-400 bar (290-5800 psi)
TYPE: VMPP/B/L 20-100/TS.W/ac VITON	CODE: 1132042151	DESCRIPTION: Steel body, as previous one
Configuration with G1"1/4 standard thread		
<i>Standard setting 160 bar @ 5 l/min (2320 psi @ 1.32 US gpm)</i>		
TYPE: VMPP/B/L 45-114/TS.S	CODE: 1132061104	DESCRIPTION: Aluminium body, range 50-220 bar (725-3200 psi)
TYPE: VMPP/B/L 45-114/TS.S/ac	CODE: 1132062101	DESCRIPTION: Steel body, as previous one
Configuration with SAE10 standard thread		
<i>Standard setting 120 bar @ 10 l/min (1740 psi @ 2.64 US gpm)</i>		
TYPE: VMPP/B/L 10-12/TS.W SAE VITON	CODE: 1132031200	DESCRIPTION: Aluminium body, range 20-400 bar (290-5800 psi)
Configuration with SAE12 standard thread		
<i>Standard setting 120 bar @ 10 l/min (1740 psi @ 2.64 US gpm)</i>		
TYPE: VMPP/B/L 20-34/TS.W VITON SAE	CODE: 1132041200	DESCRIPTION: Aluminium body, range 20-400 bar (290-5800 psi)
Configuration with SAE20 standard thread		
<i>Standard setting 160 bar @ 5 l/min (2320 psi @ 1.32 US gpm)</i>		
TYPE: VMPP/B/L 45-114/TS.S/SAE	CODE: 1132061200	DESCRIPTION: Aluminium body, range 50-220 bar (725-3200 psi)
For other steel body configurations, SAE thread and configurations with FPM (Viton) seals, please contact our Sales Dpt.		

Ordering codes and description composition

1A Direct acting pressure relief valves

TYPE	CODE	DESCRIPTION
For G1/4 ports configuration		
VMP 02/TS.G	1100000101	Range 50-220 bar (725-3200 psi)
<i>For VMP/B/L 03-14 valve</i>		
MC08A/0S2B	0MC08002000	Range 50-200 bar (725-2900 psi)
MC08R/0Y2B	0MC08002051	Range 40-200 bar (580-2900 psi)
For G3/8 and G1/2 ports configuration		
VMP 5/TS.S	1100520400	Range 50-220 bar (725-3200 psi)
VMP 5Y/TS.S	1100520406	Range 140-190 bar (2030-2755 psi)
VMP 5J/TS.S	1100520432	Range 63-200 bar (913-2900 psi)
For G1/2 and G3/4 ports configuration		
VMP 10/TS.S	1100530400	Range 50-220 bar (725-3200 psi)
VMP 10Y/TS.S	1100530407	Range 125-250 bar (1810-3600 psi)
For G3/4 and G1" ports configuration		
VMP 20/TS.S	1100540400	Range 50-220 bar (725-3200 psi)
VMP 20Y/TS.S	1100540407	Range 125-250 bar (1810-3600 psi)

1B Pilot operated pressure relief valves

TYPE	CODE	DESCRIPTION
For G1/2 ports configuration		
VMXP 10/1(XG)	XCAR110313	Range 20-400 bar (290-5800 psi)
For G3/4 and G1" ports configuration		
VMXP 20/1(XG)	X007211120	Range 20-400 bar (290-5800 psi)
For G1"1/4 ports configuration		
VMPP 45/TS.S	1130060404	Range 50-250 bar (725-3600 psi)

2 Pressure setting spring

TYPE	CODE	DESCRIPTION
For VMP 02 valve		
TV	3ML1081400	Range 5-80 bar (72.5-1160 psi)
TS	3ML1081401	Range 50-220 bar (725-3200 psi)
TR	3ML1081402	Range 180-350 bar (2600-5100 psi)
For MC08 valve		
TB	3ML1092500	Range 5-50 bar (72.5-725 psi)
TS	3ML1092501	Range 50-200 bar (725-2900 psi)
TR	3ML1092502	Range 180-350 bar (2600-5100 psi)
For VMP 5, VMP 5J and VMPP 45 valves		
TB	3MOL314311	Range 5-40 bar (72.5-580 psi)
TV	3MOL314330	Range 20-80 bar (290-1160 psi)
TS	3MOL315330	Range 50-220 bar (725-3200 psi)
TR	3ML1143600	Range 180-350 bar (2600-5100 psi)

2 Pressure setting spring (continue)

For VMP 5Y valve		
TB	3MOL314311	Range 5-80 bar (72.5-1160 psi)
TV	3MOL314330	Range 40-150 bar (580-2200 psi)
TS	3ML1143400	Range 140-190 bar (2600-5100 psi)
TR	3MOL315330	Range 180-350 bar (2600-5100 psi)
For VMP 10 valve		
TB	3MOL316410	Range 5-40 bar (72.5-580 psi)
TV	3ML1154300	Range 20-80 bar (290-1160 psi)
TS	3MOL317420	Range 50-220 bar (725-3200 psi)
TR	3MOL317440	Range 180-350 bar (2600-5100 psi)
For VMP 10Y valve		
TV	3MOL316580	Range 100-160 bar (1450-3220 psi)
TS	3MOL317560	Range 125-250 bar (1800-3600 psi)
TR	3MOL317570	Range 200-315 bar (2900-4600 psi)
For VMP 20 valve		
TB	3ML1184300	Range 5-40 bar (72.5-580 psi)
TV	3ML1174500	Range 20-80 bar (290-1160 psi)
TS	3ML1204200	Range 50-220 bar (725-3200 psi)
TR	3ML1214500	Range 180-350 bar (2600-5100 psi)
For VMP 20Y valve		
TV	3MOL318690	Range 100-160 bar (1450-3220 psi)
TS	3MOL321621	Range 125-250 bar (1800-3600 psi)
TR	3MOL321620	Range 200-315 bar (2900-4600 psi)

3 Adjusting options

TYPE	CODE	DESCRIPTION
For VMP 02		
G	-	Standard, screw type
V	4VL2307000	Handwheel
X	4COP116420	Antitamper cap
For MC08, VMP 5, VMP 10 and VMPP 45 valves		
S	-	Standard with blind nut
V	4VL2407100	Handwheel
X	4COP120420	Antitamper cap
For VMP 20 valve		
S	-	Standard with blind nut
V	4VL2407101	Handwheel
X	4AC6102800	Antitampering cap
For VMPP 10 and VMPP 20 valves		
W	-	Standard, screw type
V	XVOL105140	Handwheel
Z	5COP120420	Antitamper kit

Rating diagrams

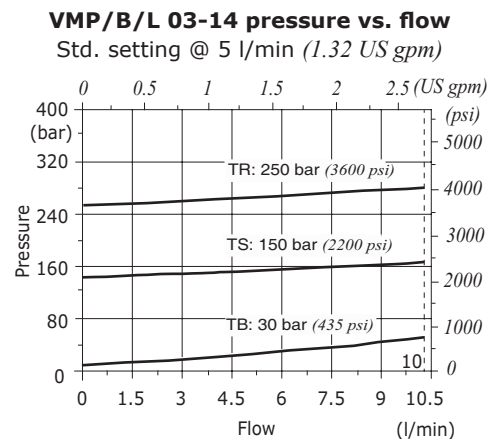
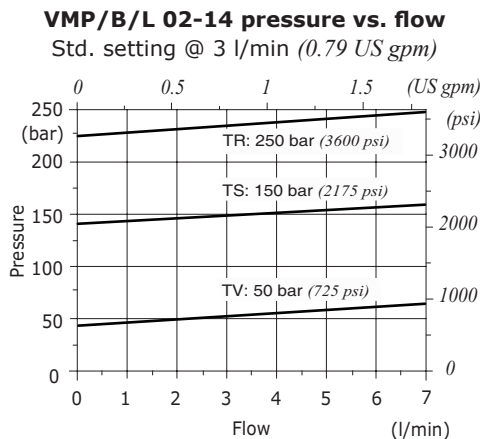

Rating diagrams

VMP/B/L 5 38-12 pressure vs. flow
Std. setting @ 5 l/min (1.32 US gpm)

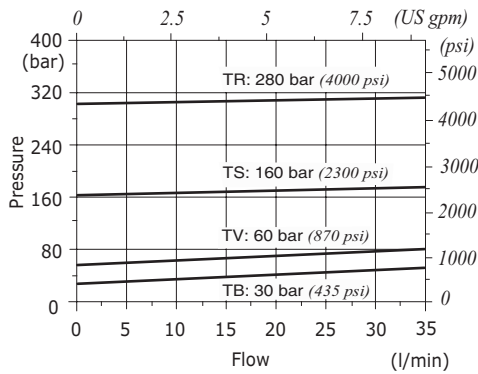

VMP/B/L 5Y 38-12 pressure vs. flow
Std. setting @ 5 l/min (1.32 US gpm)

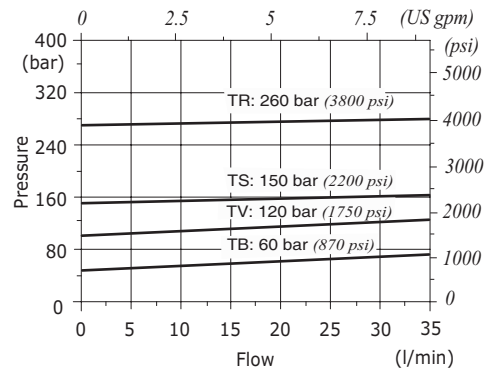

VMP/B/L 10 12-34 pressure vs. flow
Std. setting @ 5 l/min (1.32 US gpm)

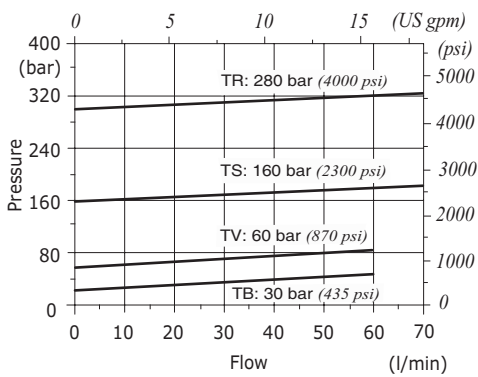

VMP/B/L 20 34-100 pressure vs. flow
Std. setting @ 5 l/min (1.32 US gpm)

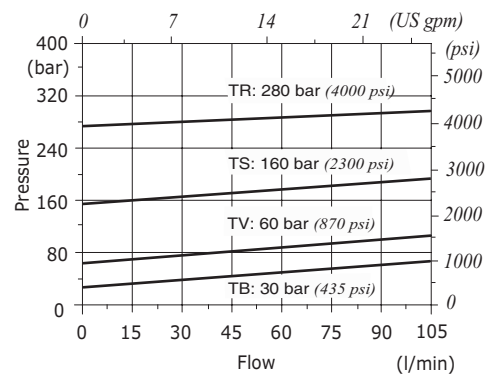

VMPP/B/L 10-12 pressure vs. flow
Std. setting @ 10 l/min (2.64 US gpm)

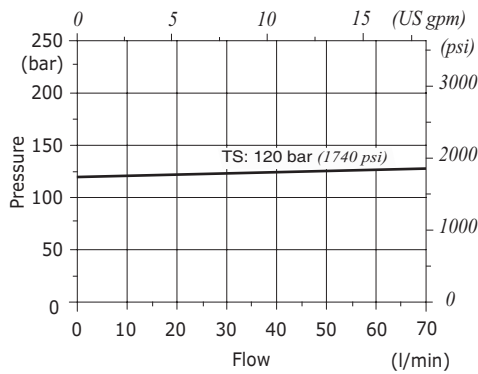

VMPP/B/L 20 34-100 pressure vs. flow
Std. setting @ 10 l/min (2.64 US gpm)

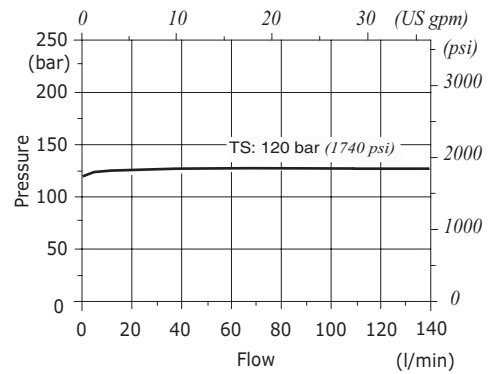

VMPP/B/L 45-114 pressure vs. flow
Std. setting @ 5 l/min (1.32 US gpm)

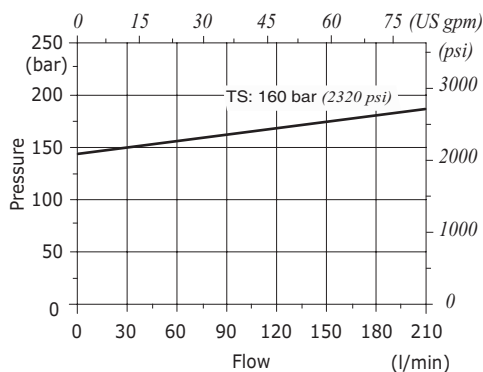



Type VMDL..20 - VMD..35 - VMD..80 pressure relief valves

- Direct acting

Technical specifications and diagrams are measured with mineral oil of 46 cSt viscosity at 40°C (104°F) temperature.

	VMDL..2001	VMDL..2002	VMD..3502	VMD..3503	VMD..8003	VMD..8004	
Nominal flow	20 l/min (5.3 US gpm)		35 l/min (9.2 US gpm)		80 l/min (21.1 US gpm)		
Max. pressure	Aluminium body = 210 bar (3050 psi) Steel body = 350 bar (5100 psi)						
Fluid	mineral based oil						
Viscosity	from 10 to 200 cSt						
Max. level of contamination	18/16/13 ISO4406						
Fluid temperature	with NBR seals from -20°C (-4°F) to 80°C (176°F)						
Environmental temp. for working conditions	from -40°C (-40°F) to 100°C (212°F)						
Weight	aluminium	0.24 kg (0.53 lb)	0.24 kg (0.53 lb)	0.40 kg (0.88 lb)	0.39 kg (0.86 lb)	0.72 kg (1.59 lb)	0.72 kg (1.59 lb)
	steel	-	-	0.85 kg (1.87 lb)	0.78 kg (1.72 lb)	1.45 kg (3.20 lb)	1.35 kg (2.98 lb)

NOTE - For different conditions, please contact Walvoil Sales Dpt.

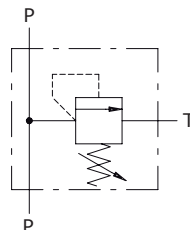

Dimensions

VMDL..20

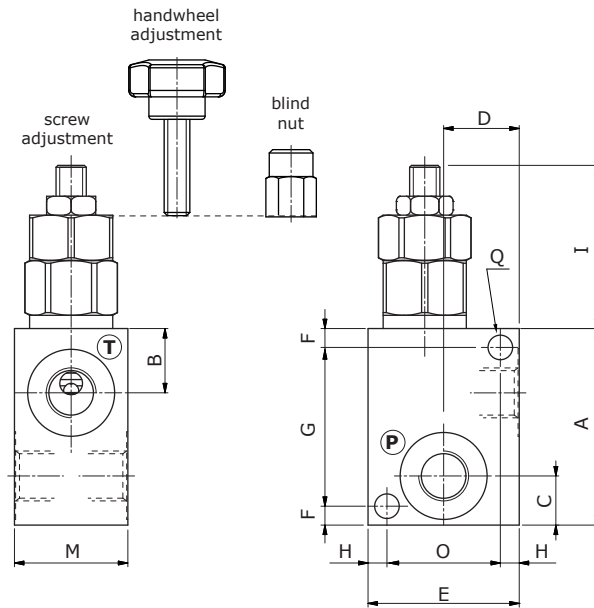

VMD..35 - VMD..80

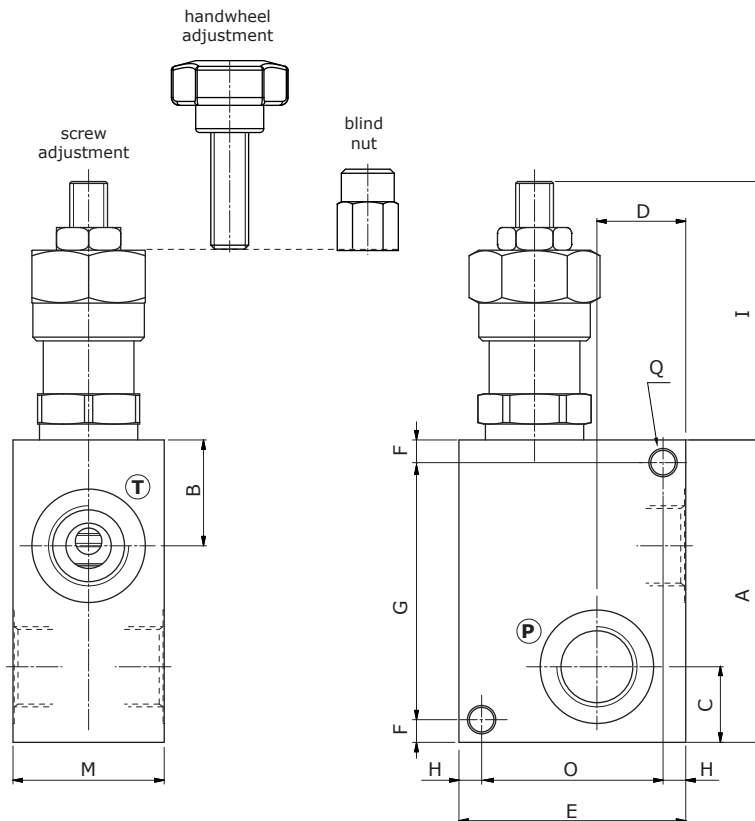

Valve type	All ports
VMDL..2001	G1/4
VMDL..2002	G3/8
VMD..3502	G3/8
VMD..3503	G1/2
VMD..8003	G1/2
VMD..8004	G3/4

Dimensions are in mm-in

Valve type	A	B	C	D	E	F	G	H	I	M	O	$\varnothing Q$
VMDL..20	45-1.77	17-0.67	13-0.51	20-0.79	40-1.57	5-0.197	42-1.65	5-0.197	44-1.73	30-1.18	30-1.18	6.5-0.256
VMD..35	65-2.56	24-0.95	17-0.67	20-0.79	50-1.97	5-0.197	53-2.09	6-0.236	64-2.52	35-1.38	34-1.34	6.5-0.256
VMD..80	80-3.15	28-1.10	20-0.79	23.5-0.93	60-2.36	6-0.236	68-2.68	6-0.236	77-3.03	40-1.57	48-1.89	6.5-0.256

Ordering codes and description composition

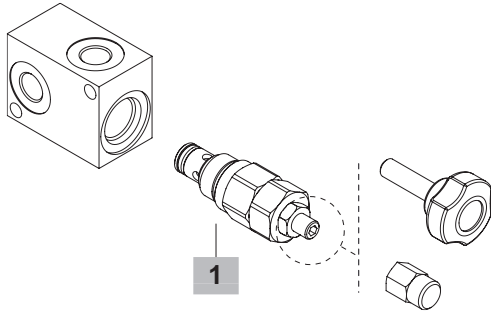
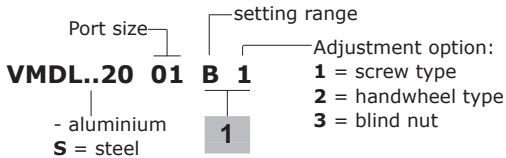

Type	Setting range bar (psi)	Std. setting bar (psi)
VMDL..20	A 5-60 (72.5-870)	40 (580)
	B 50-240 (725-3500)	100 (1450)
	C 90-350 (130-5100)	100 (1450)
	D 20-100 (290-1450)	100 (1450)
VMD..35	A 5-50 (72.5-725)	40 (580)
	B 40-210 (580-3050)	100 (1450)
	C 100-350 (1450-5100)	100 (1450)
VMD..80	A 5-50 (72.5-725)	40 (580)
	B 20-260 (290-3770)	100 (1450)
	C 120-350 (1750-5100)	120 (1740)

VMD complete valves

Standard setting 150 bar @ 5 l/min (2200 psi @ 1.32 US gpm)

TYPE	CODE	DESCRIPTION
Configuration with G1/4 standard thread		
VMDL2001B1	1110711100	Aluminium body, setting range from 50 to 240 bar (725-3500 psi)
Configuration with G3/8 standard thread		
VMDL2002B1	1110721100	Aluminium body, setting range from 50 to 240 bar (725-3500 psi)
VMD3502B1	1110821100	Aluminium body, setting range from 40 to 210 bar (580-3050 psi)
VMDS3502B1	1110822100	Steel body, setting range from 40 to 210 bar (580-3050 psi)
Configuration with G1/2 standard thread		
VMD3503B1	1110821101	Aluminium body, setting range from 40 to 210 bar (580-3050 psi)
VMD8003B1	1110831100	Aluminium body, setting range from 20 to 260 bar (290-3770 psi)
VMDS3503B1	1110822101	Steel body, setting range from 40 to 210 bar (580-3050 psi)
VMDS8003B1	1110832100	Steel body, setting range from 20 to 260 bar (290-3770 psi)
Configuration with G3/4 standard thread		
VMD8004B1	1110831101	Aluminium body, setting range from 20 to 260 bar (290-3770 psi)
VMDS8004B1	1110832101	Steel body, setting range from 20 to 260 bar (290-3770 psi)

For different configurations and SAE thread please contact our Sales Dpt.

1 Direct acting pressure relief valves

Standard setting 150 bar @ 5 l/min (2200 psi @ 1.32 US gpm)

TYPE	CODE	DESCRIPTION
For VMDL..20 valve		
MC08F/0G2B	0MC08002069	Screw adjustment from 50 to 240 bar (725-3500 psi)
For VMD..35 valve		
VMDC35B1(M20X1,5)	1100220400	Screw adjustment from 40 to 210 bar (580-3050 psi)
For VMD..80 valve		
VMDC80B1(M26X1,5)	1100230400	Screw adjustment from 40 to 260 bar (290-3770 psi)

Rating diagrams

VMDL..20 pressure vs. flow
standard setting @ 5 l/min (1.32 US gpm)

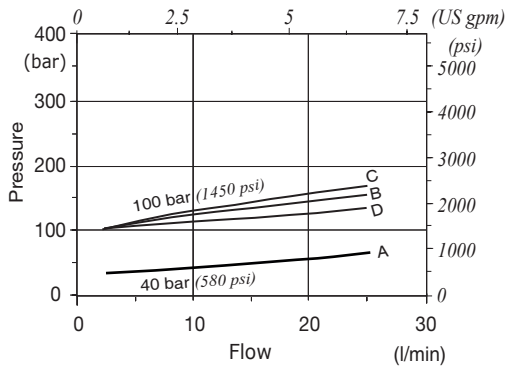

VMD..35 pressure vs. flow
standard setting @ 5 l/min (1.32 US gpm)

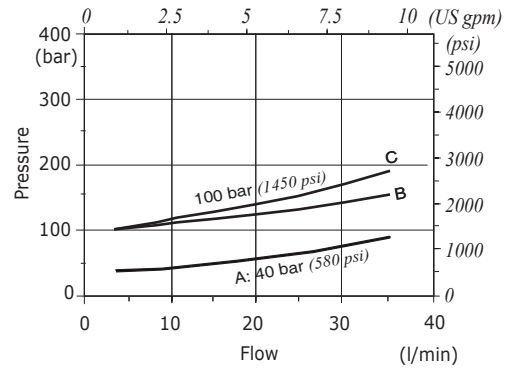

VMD..80 pressure vs. flow
standard setting @ 5 l/min (1.32 US gpm)

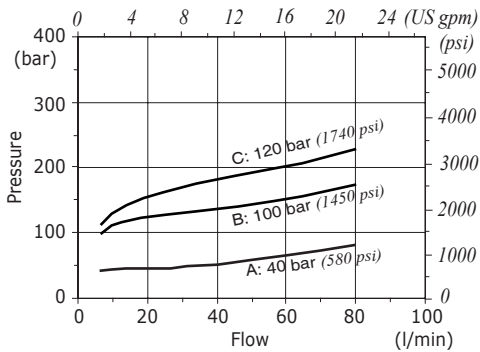



Type VMPD/B pressure relief valves

- Differential pressure relief valve
- Poppet type

Technical specifications and diagrams are measured with mineral oil of 46 cSt viscosity at 40°C (104°F) temperature.

	VMPD/B 38	VMPD/B 12	VMPD/B 34	VMPD/B 100	
Nominal flow	35 l/min (9.2 US gpm)	60 l/min (16 US gpm)	100 l/min (26.4 US gpm)	180 l/min (47.6 US gpm)	
Max. pressure	Aluminium body = 210 bar (3050 psi) Steel body = 350 bar (5100 psi)				
Oil leakage at 80% of max. setting	0.25 cm ³ /min (0.01 in ³ /min)				
Fluid	mineral based oil				
Viscosity	from 10 to 200 cSt				
Max. level of contamination	18/16/13 ISO4406				
Fluid temperature	with NBR seals from -20°C (-4°F) to 80°C (176°F)				
Environmental temp. for working conditions	from -40°C (-40°F) to 100°C (212°F)				
Weight	alum.	0.50 kg (1.10 lb)	0.68 kg (1.50 lb)	1.12 kg (2.47 lb)	1.42 kg (3.13 lb)
	steel	0.92 kg (2.03 lb)	1.28 kg (2.82 lb)	2.04 kg (4.50 lb)	2.72 kg (6.65 lb)

NOTE - For different conditions, please contact Walvoil Sales Dpt.

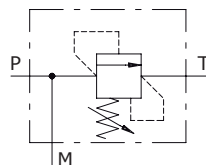

Dimensions

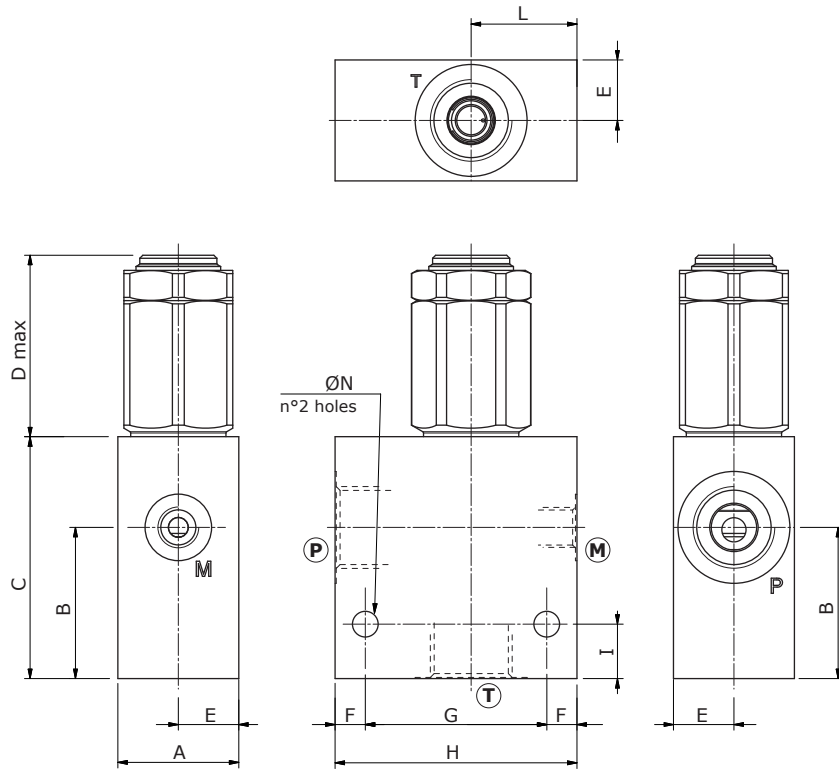

Valve type	T	P	M
VMPD/B 38	G3/8	G3/8	G1/4
VMPD/B 12	G1/2	G1/2	G1/4
VMPD/B 34	G3/4	G3/4	G1/4
VMPD/B 100	G1"	G1"	G1/4

Dimensions are in mm-in

Valve type	A	B	C	D max	E	F	G	H	I	L	ØN
VMPD/B 38	30-1.18	38-1.50	60-2.36	57.7-2.27	15-0.59	10-0.39	40-1.57	60-2.36	15-0.59	30-1.18	6.5-0.25
VMPD/B 12	35-1.38	43-1.69	65-2.55	56.2-2.21	17.5-0.69	10-0.39	50-1.97	70-2.75	15-0.59	33-1.30	8.5-0.33
VMPD/B 34	40-1.57	50-1.97	80-3.15	68.8-2.71	20-0.79	10-0.39	60-2.36	80-3.15	18-0.71	35-1.38	8.5-0.33
VMPD/B 100	50-1.97	59-2.32	90-3.54	68.8-2.71	25-0.98	10-0.39	70-2.75	90-3.54	20-0.79	42-1.65	10.5-0.41

Ordering codes and description composition

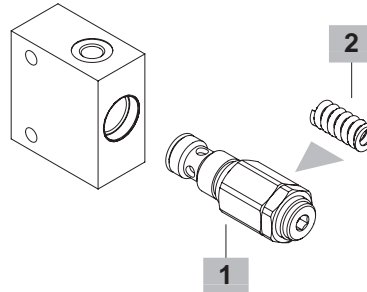
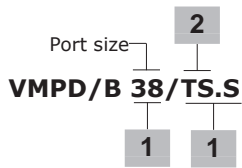

VMPD/B complete valves

TYPE	CODE	DESCRIPTION
Configuration with G3/8 standard thread		
VMPD/B 38/TS.S	1121021102	Aluminium body, setting range 5-210 bar (72.5-3045 psi), std. setting 150 bar @ 5 l/min (2175 psi at 1.32 US gpm)
VMPD/B 38/TS.S/ac	1121022102	Steel body, as previous one
Configuration with G1/2 standard thread		
VMPD/B 12/TS.S	1121031102	Aluminium body, setting range 5-210 bar (72.5-3045 psi), std. setting 150 bar @ 5 l/min (2175 psi at 1.32 US gpm)
VMPD/B 12/TS.S/ac	1121032100	Steel body, as previous one)
Configuration with G3/4 standard thread		
VMPD/B 34/TS.S	1121041102	Aluminium body, setting range 5-210 bar (72.5-3045 psi), std. setting 150 bar @ 5 l/min (2175 psi at 1.32 US gpm)
VMPD/B 34/TS.S/ac	1121042100	Steel body, as previous one
Configuration with G1" standard thread		
VMPD/B 100/TS.S	1121051102	Aluminium body, setting range 5-210 bar (72.5-3045 psi), std. setting 150 bar @ 5 l/min (2175 psi at 1.32 US gpm)
VMPD/B 100/TR.S/ac	1121052100	Steel body, setting range 50-350 bar (725-5100 psi), std. setting 250 bar @ 5 l/min (3600 psi at 1.32 US gpm)

For other steel body configurations, SAE thread and configurations with FPM (Viton) seals please contact our Sales Dpt.

1 Direct acting pressure relief valves

Standard setting 150 bar at 5 l/min (2175 psi at 1.32 US gpm)

TYPE	CODE	DESCRIPTION
For G3/8 ports configuration		
VMPD 38/TS.S	1120020402	Setting range 5-210 bar (72.5-3050 psi)
For G1/2 ports configuration		
VMPD 12/TS.S	1120030402	Setting range 5-210 bar (72.5-3050 psi)
For G3/4 and G1" ports configuration		
VMPD 34/TS.S	1120040402	Setting range 5-210 bar (72.5-3050 psi)

2 Pressure setting spring

TYPE	CODE	DESCRIPTION
For VMPD/B38 valve		
TS	3ML1144000	Setting range 5-210 bar (72.5-3050 psi)
TR	3ML1144001	Setting range 50-350 bar (725-5100 psi)
For VMPD/B12 valve		
TS	3ML1164000	Setting range 5-210 bar (72.5-3050 psi)
TR	3ML1164001	Setting range 50-350 bar (725-5100 psi)
For VMPD/B34 and VMPD/B100 valves		
TS	3ML1194500	Setting range 5-210 bar (72.5-3050 psi)
TR	3ML1194501	Setting range 50-350 bar (725-5100 psi)

Rating diagrams

VMPD/B 38 pressure vs. flow

Std. setting @ 5 l/min (1.32 US gpm)

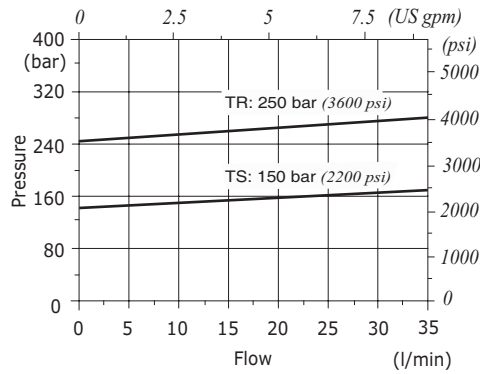

VMPD/B 12 pressure vs. flow

Std. setting @ 5 l/min (1.32 US gpm)

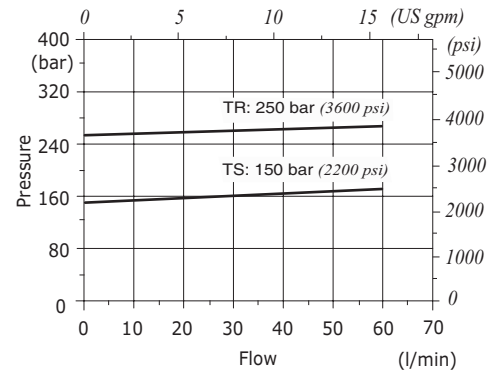

VMPD/B 34 pressure vs. flow

Std. setting @ 5 l/min (1.32 US gpm)

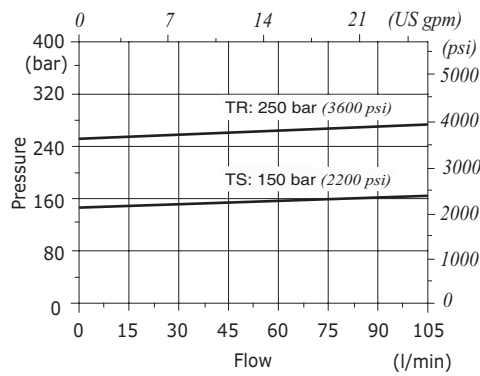

VMPD/B 100 pressure vs. flow

Std. setting @ 5 l/min (1.32 US gpm)

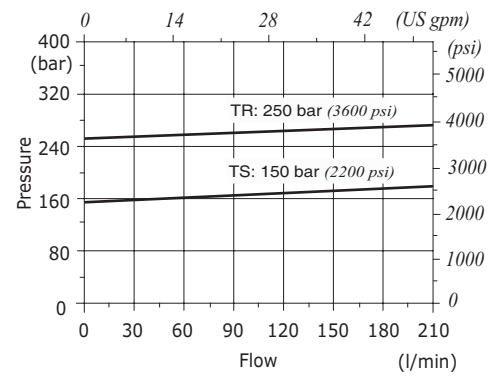

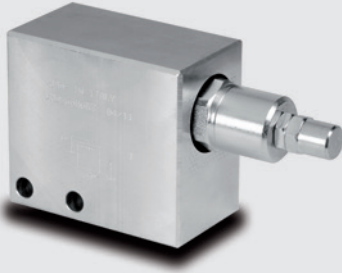

Type VMD150 pressure relief valves

- Differential acting

Technical specifications and diagrams are measured with mineral oil of 46 cSt viscosity at 40°C (104°F) temperature.

	VMD15005	VMD15006
Nominal flow	150 l/min (39.6 US gpm)	
Max. pressure	Aluminium body = 210 bar (3050 psi)	
Fluid	mineral based oil	
Viscosity	from 10 to 200 cSt	
Max. level of contamination	18/16/13 ISO4406	
Fluid temperature	with NBR seals from -20°C (-4°F) to 80°C (176°F)	
Environmental temperature for working conditions	from -40°C (-40°F) to 100°C (212°F)	
Weight	aluminium 1.49 kg (3.28 lb)	1.41 kg (3.11 lb)

NOTE - For different conditions, please contact Walvoil Sales Dpt.

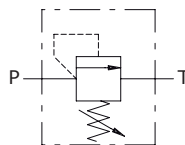

Dimensions

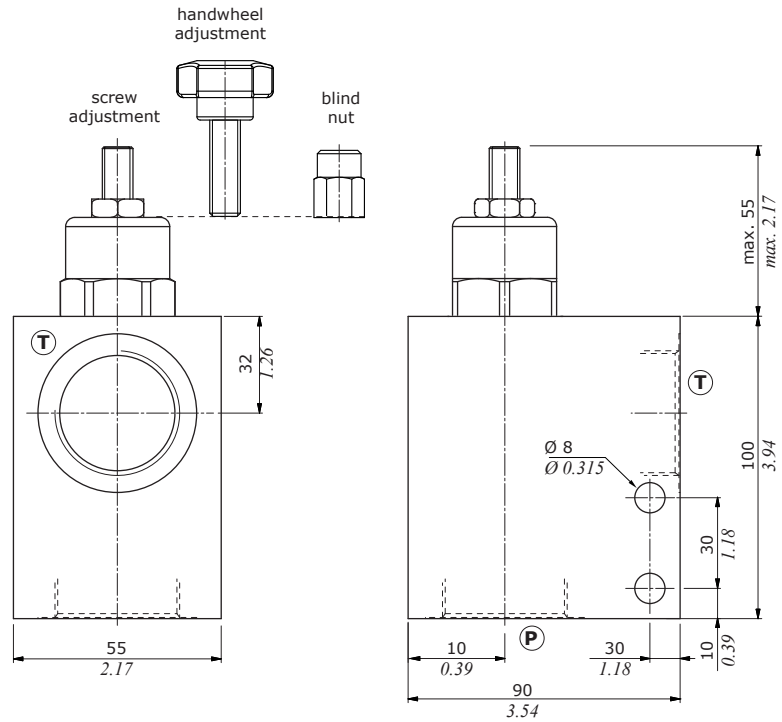

Valve type	All ports
VMD15005	G1"
VMD15006	G1"1/4

Ordering codes and description composition

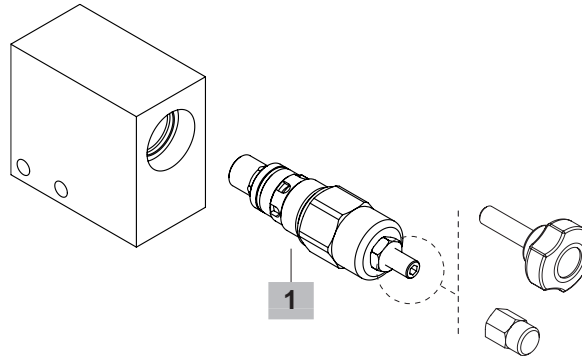
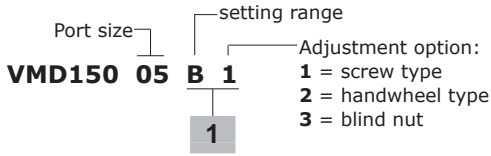

VMD150 complete valves

Standard setting 250 bar @ 5 l/min (3600 psi @ 1.32 US gpm)

TYPE	CODE	DESCRIPTION
------	------	-------------

Configuration with G1 standard thread

VMD15005B1	1121251100	Aluminium body, setting range 30-350 bar (435-5100 psi)
-------------------	------------	---

Configuration with G1 1/4 standard thread

VMD15006B1	1121261100	Aluminium body, setting range 30-350 bar (435-5100 psi)
-------------------	------------	---

For different configurations and SAE thread please contact our Sales Dpt.

1 Direct acting pressure relief valves

TYPE	CODE	DESCRIPTION
VMDC150B1	1120250400	Screw adjustment, setting range 30-350 bar (435-5100 psi), std setting 100 bar @ 5 l/min (1450 psi @ 1.32 US gpm)

Rating diagrams

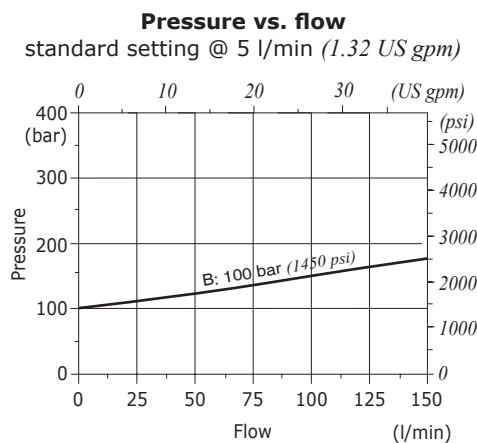



Type VMDS150 pressure relief valves

- Differential acting

Technical specifications and diagrams are measured with mineral oil of 46 cSt viscosity at 40°C (104°F) temperature.

	VMDS15005	VMDS15006
Nominal flow	150 l/min (39.6 US gpm)	
Max. pressure	Steel body = 350 bar (5100 psi)	
Fluid	mineral based oil	
Viscosity	from 10 to 200 cSt	
Max. level of contamination	18/16/13 ISO4406	
Fluid temperature	with NBR seals from -20°C (-4°F) to 80°C (176°F)	
Environmental temperature for working conditions	from -40°C (-40°F) to 100°C (212°F)	
Weight	steel 2.76 kg (6.08 lb)	2.43 kg (5.42 lb)

NOTE - For different conditions, please contact Walvoil Sales Dpt.

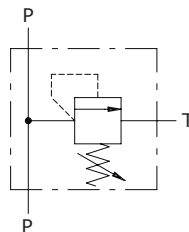

Dimensions

Valve type	All ports
VMDS15005	G1"
VMDS150 06	G1"1/4

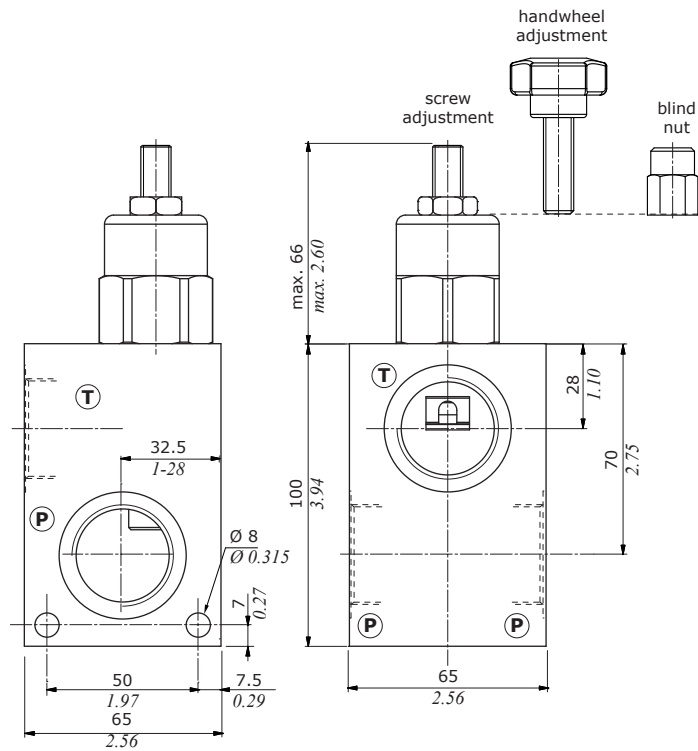

Ordering codes and description composition

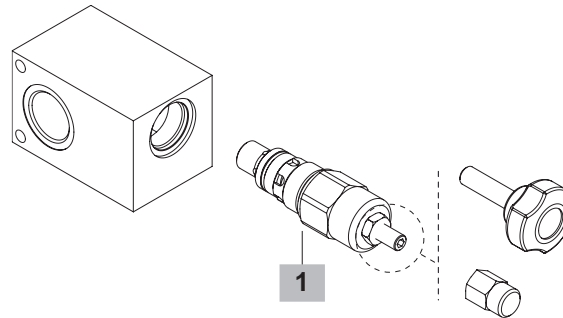
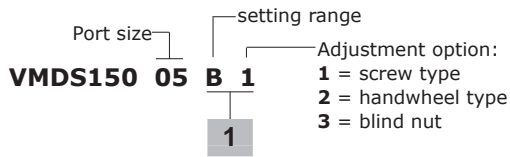

VMDS150 complete valves

Standard setting 250 bar @ 5 l/min (3600 psi @ 1.32 US gpm)

CODE DESCRIPTION

Configuration with G1 standard thread

VMDS15005B1 1121352100 Steel body, setting range 30-350 bar (435-5100 psi)

Configuration with G1 1/4 standard thread

VMDS15006B1 1121362100 Steel body, setting range 30-350 bar (435-5100 psi)

For different configurations and SAE thread please contact our Sales Dpt.

1 Direct acting pressure relief valves

TYPE	CODE	DESCRIPTION
VMDC150B1	1120250400	Screw adjustment, setting range 30-350 bar (435-5100 psi), std setting 100 bar @ 5 l/min (1450 psi @ 1.32 US gpm)

Rating diagrams

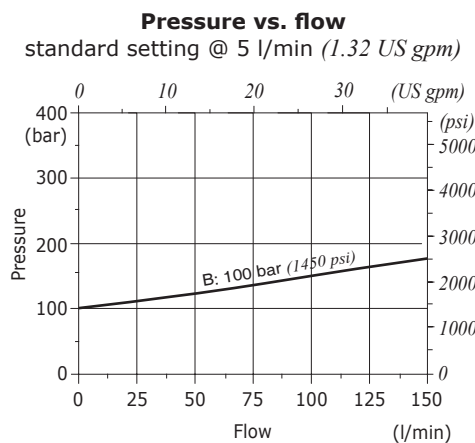



Type VMP/VE pressure relief valves

- Piloted operated
- With electric venting

Technical specifications and diagrams are measured with mineral oil of 46 cSt viscosity at 40°C (104°F) temperature.

	VMP/VE 14	VMP/VE 38	VMP/VE 12	VMP/VE 34	VMP/VE 100	VMP/VE 114	
Nominal flow	20 l/min (5.3 US gpm)	35 l/min (9.2 US gpm)	90 l/min (23.8 US gpm)	90 l/min (23.8 US gpm)	150 l/min (39.6 US gpm)	250 l/min (66 US gpm)	
Max. pressure	Aluminium body = 210 bar (3050 psi) Steel body = 350 bar (5100 psi)						
Oil leakage at 80% of max. setting	3 cm ³ /min (0.18 in ³ /min)	3 cm ³ /min (0.18 in ³ /min)	200 cm ³ /min (12.20 in ³ /min)	200 cm ³ /min (12.20 in ³ /min)	200 cm ³ /min (12.20 in ³ /min)	200 cm ³ /min (12.20 in ³ /min)	
Fluid	mineral based oil						
Viscosity	from 10 to 200 cSt						
Max. level of contamination	18/16/13 ISO4406						
Fluid temperature	with NBR seals from -20°C (-4°F) to 80°C (176°F)						
Environmental temp. for working conditions	from -40°C (-40°F) to 100°C (212°F)						
Weight	aluminium	0.67 kg (1.48 lb)	0.66 kg (1.46 lb)	1.42 kg (3.13 lb)	1.26 kg (2.78 lb)	1.92 kg (4.23 lb)	3.77 kg (8.31 lb)
	steel	1.13 kg (2.49 lb)	1.27 kg (2.80 lb)	2.58 kg (5.69 lb)	2.57 kg (5.67 lb)	3.95 kg (8.71 lb)	7.73 kg (17.04 lb)

NOTE - For different conditions, please contact Walvoil Sales Dpt.

VMP/VE 14-38

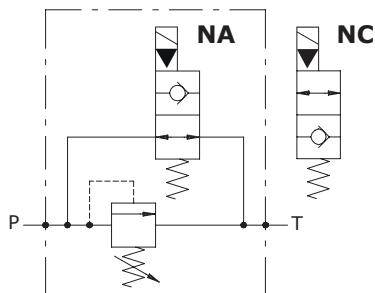

VMP/VE 12-34-100-114

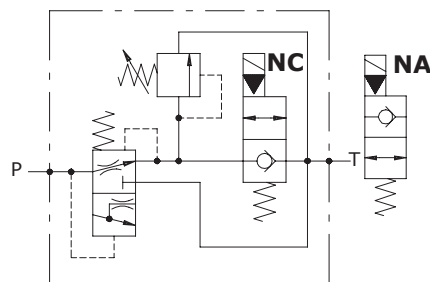

Dimensions

Valve type	All ports
VMP/VE 14	G1/4
VMP/VE 38	G3/8
Valve type	All ports
VMP/VE 38/SAE	SAE8

Dimensions are in mm-in

Valve type	A*
VMP/VE 14	66.5-2.62
VMP/VE 38 VMP/VE 38/SAE	66.5-2.62

(*) With normally open valve

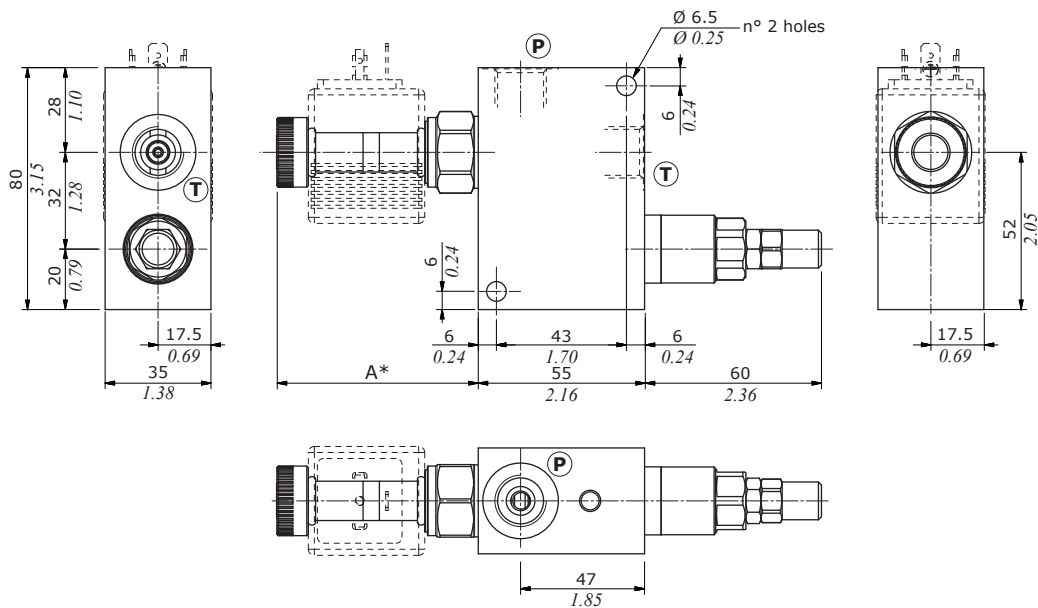

Valve type	All ports
VMP/VE 12	G1/2
VMP/VE 34	G3/4
VMP/VE 100	G1"
VMP/VE 114	G1 1/4"
Valve type	All ports
VMP/VE 12/SAE	SAE10
VMP/VE 34/SAE	SAE12
VMP/VE 100/SAE	SAE16

Dimensions are in mm-in

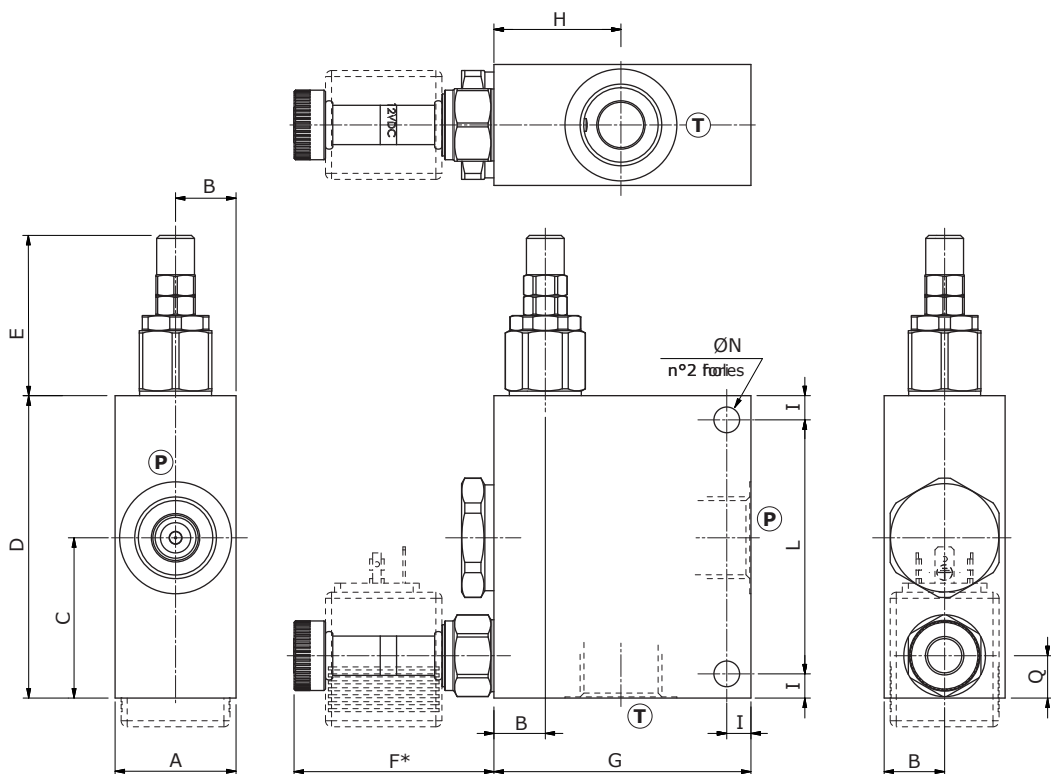

Valve type	A	B	C	D	E	F*	G	H	I	L	ØN	Q
VMP/VE 12 VMP/VE 12/SAE	40-1.57	20-0.70	53-2.09	100-3.93	51.5-2.03	66.5-2.62	85-3.35	42-1.65	8-0.31	84-3.31	8.5-0.33	14-0.55
VMP/VE 34 VMP/VE 34/SAE	40-1.57	20-0.70	53-2.09	100-3.93	51.5-2.03	66.5-2.62	85-3.35	42-1.65	8-0.31	84-3.31	8.5-0.3	14-0.55
VMP/VE 100 VMP/VE 100/SAE	50-1.97	25-0.98	60-2.36	110-4.33	53-2.09	66.5-2.62	100-3.94	50-1.97	10-0.40	90-3.54	10.5-0.41	17-0.67
VMP/VE 114	70-2.75	35-2.75	72-2.83	130-5.12	53-2.09	66.5-2.62	130-5.12	62-2.44	12-0.47	106-4.17	12.5-0.49	18-0.71

(*) With normally open valve

Ordering codes and description composition

VMP/VE complete valves

With direct acting valves; standard setting is referred to 5 l/min (1.32 US gpm)

Configuration with G1/4 standard thread

TYPE: **VMP/VE 14/NA/5.TS.S/EC08M** CODE: 1116011104
DESCRIPTION: Aluminium body, range 50-220 bar (725-3200 psi).
Std setting 160 bar (2300 psi), with (NA) normally open solenoid valve
TYPE: **VMP/VE 14/NC/5.TS.S/EC08M** CODE: 1116011105
DESCRIPTION: As previous one, with (NC) normally closed solenoid valve

Configuration with G3/8 standard thread

TYPE: **VMP/VE 38/NA/5.TS.S/EC08M** CODE: 1116021104
DESCRIPTION: Aluminium body, range 50-220 bar (725-3200 psi).
Std setting 160 bar (2300 psi), with (NA) normally open solenoid valve
TYPE: **VMP/VE 38/NC/5.TS.S/EC08M** CODE: 1116021105
DESCRIPTION: As previous one, with (NC) normally closed solenoid valve
TYPE: **VMP/VE 38/NA/5.TR.S/EC08M/ac** CODE: 1116022101
DESCRIPTION: Steel body, range 180-350 bar (2600-5100 psi).
Std setting 280 bar (4050 psi), with (NA) normally open solenoid valve
TYPE: **VMP/VE 38/NC/5.TR.S/EC08M/ac** CODE: 1116022100
DESCRIPTION: As previous one, with (NC) normally closed solenoid valve

Configuration with G1/2 standard thread

TYPE: **VMP/VE 12/NA/03.TS.S/EC08M** CODE: 1116031102
DESCRIPTION: Aluminium body, range 50-200 bar (725-2900 psi).
Std setting 150 bar (2200 psi), with (NA) normally open solenoid valve
TYPE: **VMP/VE 12/NC/03.TS.S/EC08M** CODE: 1116031103
DESCRIPTION: As previous one, with (NC) normally closed solenoid valve
TYPE: **VMP/VE 12/NA/03.TR.S/EC08M/ac** CODE: 1116032100
DESCRIPTION: Steel body, range 180-350 bar (2600-5100 psi).
Std setting 250 bar (3600 psi), with (NA) normally open solenoid valve
TYPE: **VMP/VE 12/NC/03.TR.S/EC08M/ac** CODE: 1116032103
DESCRIPTION: As previous one, with (NC) normally closed solenoid valve

Configuration with G3/4 standard thread

TYPE: **VMP/VE 34/NA/03.TS.S/EC08M** CODE: 1116041102
DESCRIPTION: Aluminium body, range 50-200 bar (725-2900 psi).
Std setting 150 bar (2200 psi), with (NA) normally open solenoid valve
TYPE: **VMP/VE 34/NC/03.TS.S/EC08M** CODE: 1116041103
DESCRIPTION: As previous one, with (NC) normally closed solenoid valve
TYPE: **VMP/VE 34/NA/03.TR.S/EC08M/ac** CODE: 1116042100
DESCRIPTION: Steel body, range 150-350 bar (2175-5100 psi).
Std setting 250 bar (3600 psi), with (NA) normally open solenoid valve
TYPE: **VMP/VE 34/NC/03.TR.S/EC08M/ac** CODE: 1116042101
DESCRIPTION: As previous one, with (NC) normally closed solenoid valve

Configuration with G1" standard thread

TYPE: **VMP/VE 100/NA/03.TS.S/EC08M** CODE: 1116051102
DESCRIPTION: Aluminium body, range 50-200 bar (725-2900 psi).
Std setting 150 bar (2200 psi), with (NA) normally open solenoid valve
TYPE: **VMP/VE 100/NC/03.TS.S/EC08M** CODE: 1116051103
DESCRIPTION: As previous one, with (NC) normally closed solenoid valve
TYPE: **VMP/VE 100/NA/03.TR.S/EC08M/ac** CODE: 1116052100
DESCRIPTION: Steel body, range 150-350 bar (2175-5100 psi).
Std setting 250 bar (3600 psi), with (NA) normally open solenoid valve
TYPE: **VMP/VE 100/NC/03.TR.S/EC08M/ac** CODE: 1116052101
DESCRIPTION: As previous one, with (NC) normally closed solenoid valve

Configuration with G1"1/4 standard thread

TYPE: **VMP/VE 114/NA/03.TS.S/EC08M** CODE: 1116061102
DESCRIPTION: Aluminium body, range 50-200 bar (725-2900 psi).
Std setting 150 bar (2200 psi), with (NA) normally open solenoid valve
TYPE: **VMP/VE 114/NC/03.TS.S/EC08M** CODE: 1116061103
DESCRIPTION: As previous one, with (NC) normally closed solenoid valve
TYPE: **VMP/VE 114/NA/03.TR.S/EC08M/ac** CODE: 1116062100
DESCRIPTION: Steel body, range 150-350 bar (2175-5100 psi).
Std setting 250 bar (3600 psi), with (NA) normally open solenoid valve
TYPE: **VMP/VE 114/NC/03.TR.S/EC08M/ac** CODE: 1116062101
DESCRIPTION: As previous one, with (NC) normally closed solenoid valve

Configuration with SAE8 standard thread

TYPE: **VMP/VE 38/NA/5.TS.S/EC08M/SAE** CODE: 1116021200
DESCRIPTION: Aluminium body, range 50-220 bar (725-3200 psi).
Std setting 160 bar (2300 psi), with (NA) normally open solenoid valve

Configuration with SAE10 standard thread

TYPE: **VMP/VE 12/NA/03.TS.S/EC08M** CODE: 1116031200
DESCRIPTION: Aluminium body, range 50-200 bar (725-2900 psi).
Std setting 150 bar (2200 psi), with (NA) normally open solenoid valve

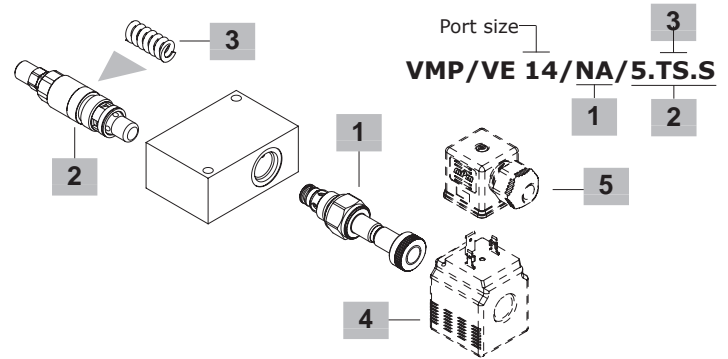

VMP/VE complete valves

Configuration with SAE12 standard thread

TYPE: **VMP/VE 34/NA/03.TS.S/EC08M/SAE** CODE: 1116041201
DESCRIPTION: Aluminium body, range 50-200 bar (725-2900 psi).
Std setting 150 bar (2200 psi), with (NA) normally open solenoid valve

Configuration with SAE16 standard thread

TYPE: **VMP/VE 100/NA/03.TS.S/EC08M/SAE** CODE: 1116051200
DESCRIPTION: Aluminium body, range 50-200 bar (725-2900 psi).
Std setting 150 bar (2200 psi), with (NA) normally open solenoid valve

1 Solenoid valves

TYPE	CODE	DESCRIPTION
EC08M/10NB	0EC08002031	(NA) normally open, electric venting
EC08M/20NB	0EC08002032	(NC) normally closed, electric venting

Note: BER coils are required

2 Direct acting pressure relief valves

Standard setting is referred to 5 l/min (1.32 US gpm)

TYPE	CODE	DESCRIPTION
For G3/8, G1/4 and SAE8 ports configuration		
VMP 5/TS.S	1100520400	Setting range 50-220 bar (725-3200 psi) Standard setting 160 bar (2300 psi)
VMP 5/TR.S	1100520401	Setting range 180-350 bar (2600-5100 psi) Standard setting 280 bar (4050 psi)
For G1/2, G3/4, G1" and G1"1/4 ports configuration		
MC08A/0S2B	0MC08002000	Setting range 50-200 bar (725-2900 psi) Standard setting 150 bar (2200 psi)
MC08A/0S3B	0MC08002002	Setting range 150-350 bar (2200-5100 psi) Standard setting 250 bar (3600 psi)

3 Pressure setting springs

TYPE	CODE	DESCRIPTION
For VMP 5 valves		
TB	3MOL314311	Setting range 5-40 bar (72.5-580 psi)
TV	3MOL314330	Setting range 20-80 bar (290-1160 psi)
TS	3MOL315330	Setting range 50-220 bar (725-3200 psi)
TR	3ML1143600	Setting range 180-350 bar (2600-5100 psi)
For MC08A valves		
TB	3ML1092500	Setting range 5-50 bar (72.5-725 psi)
TS	3ML1092501	Setting range 50-200 bar (725-2900 psi)
TR	3ML1092502	Setting range 180-350 bar (2600-5100 psi)

4 Coils

TYPE	CODE	DESCRIPTION
BER 12VDC	4SLE001200A	12VDC-ISO4400, BER type coil

For complete coil list see from page 437

5 Connector

TYPE	CODE	DESCRIPTION
ISO4400	4CN1009995	Connector

For complete connectors list see from page 437
For other steel body configurations, other port sizes and configurations with FPM (Viton) seals please contact our Sales Dpt.

Rating diagrams

VMP/VE 14 pressure vs. flow

Std. setting @ 5 l/min (1.32 US gpm)

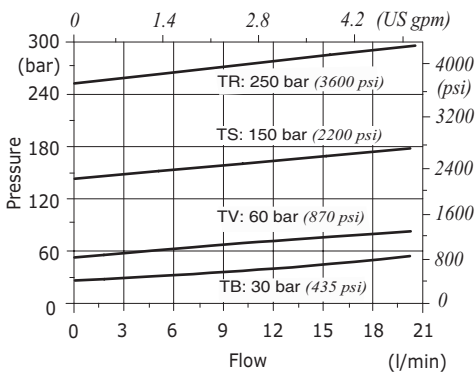

VMP/VE 14 pressure drop diagram

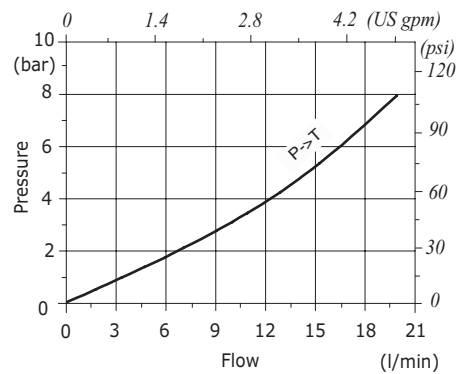

VMP/VE 38 pressure vs. flow

Std. setting @ 5 l/min (1.32 US gpm)

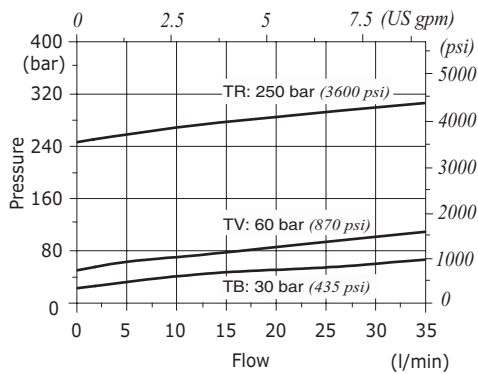

VMP/VE 38 pressure drop diagram

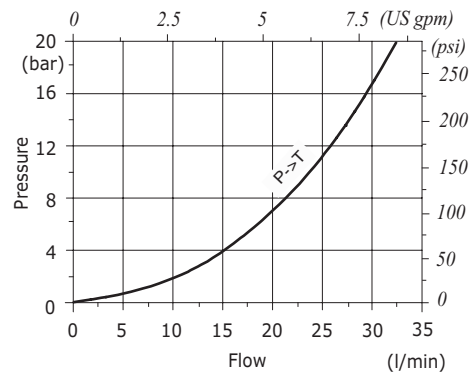

VMP/VE 12-34 pressure vs. flow

Std. setting @ 5 l/min (1.32 US gpm)

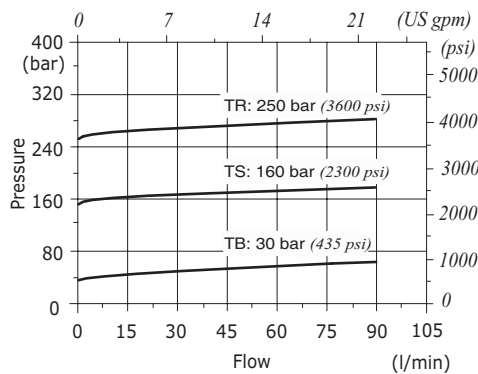

VMP/VE 12-34 pressure drop diagram

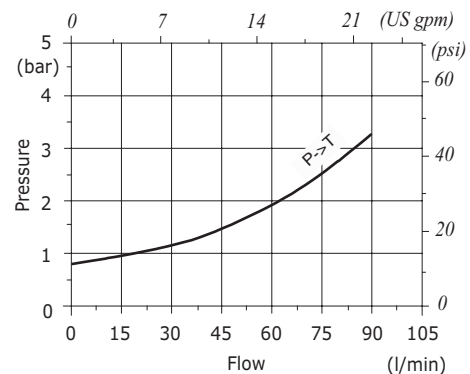

VMP/VE 100-114 pressure vs. flow

Std. setting @ 5 l/min (1.32 US gpm)

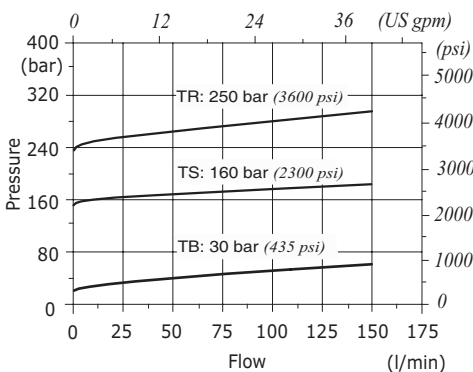

VMP/VE 100 pressure drop diagram

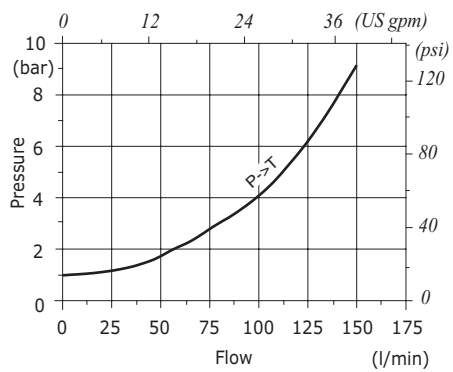

VMP/VE 114 pressure drop diagram

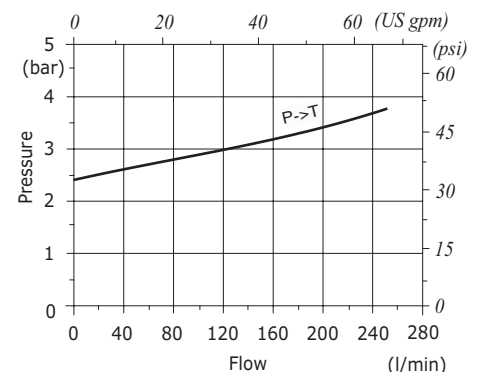



Type PBL pressure relief valves

- Subplates with pressure relief valve face mounting cetop 3 (6-38) or 5 (10-12)

Technical specifications and diagrams are measured with mineral oil of 46 cSt viscosity at 40°C (104°F) temperature.

	PBL 6/VMP 38	PBL 6/VMP 38/5Y	PBL 10/VMP 12	
Nominal flow	35 l/min (9.2 US gpm)	35 l/min (9.2 US gpm)	60 l/min (16 US gpm)	
Max. pressure	Aluminium body = 210 bar (3050 psi) Steel body = 350 bar (5100 psi)			
Oil leakage at 80% of max. setting	3 cm ³ /min (0.18 in ³ /min)	1 cm ³ /min (0.06 in ³ /min)	5 cm ³ /min (0.30 in ³ /min)	
Fluid	mineral based oil			
Viscosity	from 10 to 200 cSt			
Max. level of contamination	18/16/13 ISO4406			
Fluid temperature	with NBR seals from -20°C (-4°F) to 80°C (176°F)			
Environmental temp. for working conditions	from -40°C (-40°F) to 100°C (212°F)			
Weight	<i>aluminium</i>	0.80 kg (1.76 lb)	0.80 kg (1.76 lb)	1.70 kg (3.75 lb)
	<i>steel</i>	1.98 kg (4.36 lb)	1.98 kg (4.36 lb)	4.29 kg (9.46 lb)

NOTE - For different conditions, please contact Walvoil Sales Dpt.

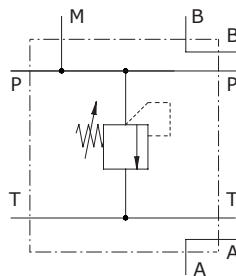

Dimensions

Valve type	(P) (T) (A) (B) (M)	(M)
PBL 6/VMP 38	G3/8	G1/4
PBL 6/VMP 38/5Y	G3/8	G1/4

Valve type	(P) (T) (A) (B) (M)	(M)
PBL 6/VMP 38/SAE	SAE8	SAE6

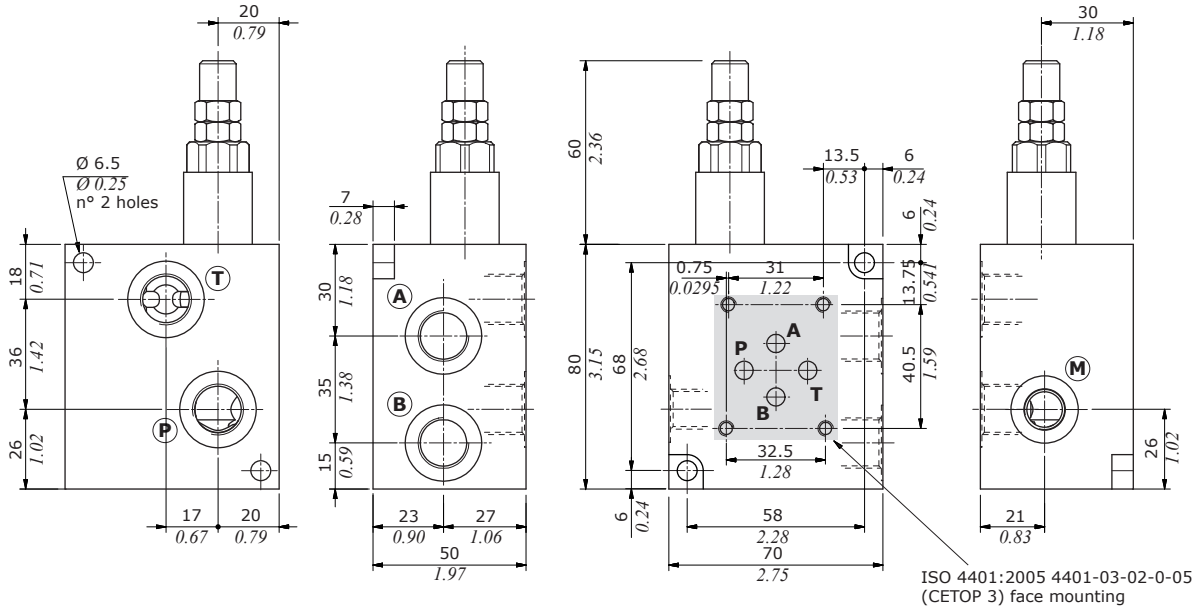

Valve type	(P) (T) (A) (B) (M)	(M)
PBL 10/VMP 12	G1/2	G1/4

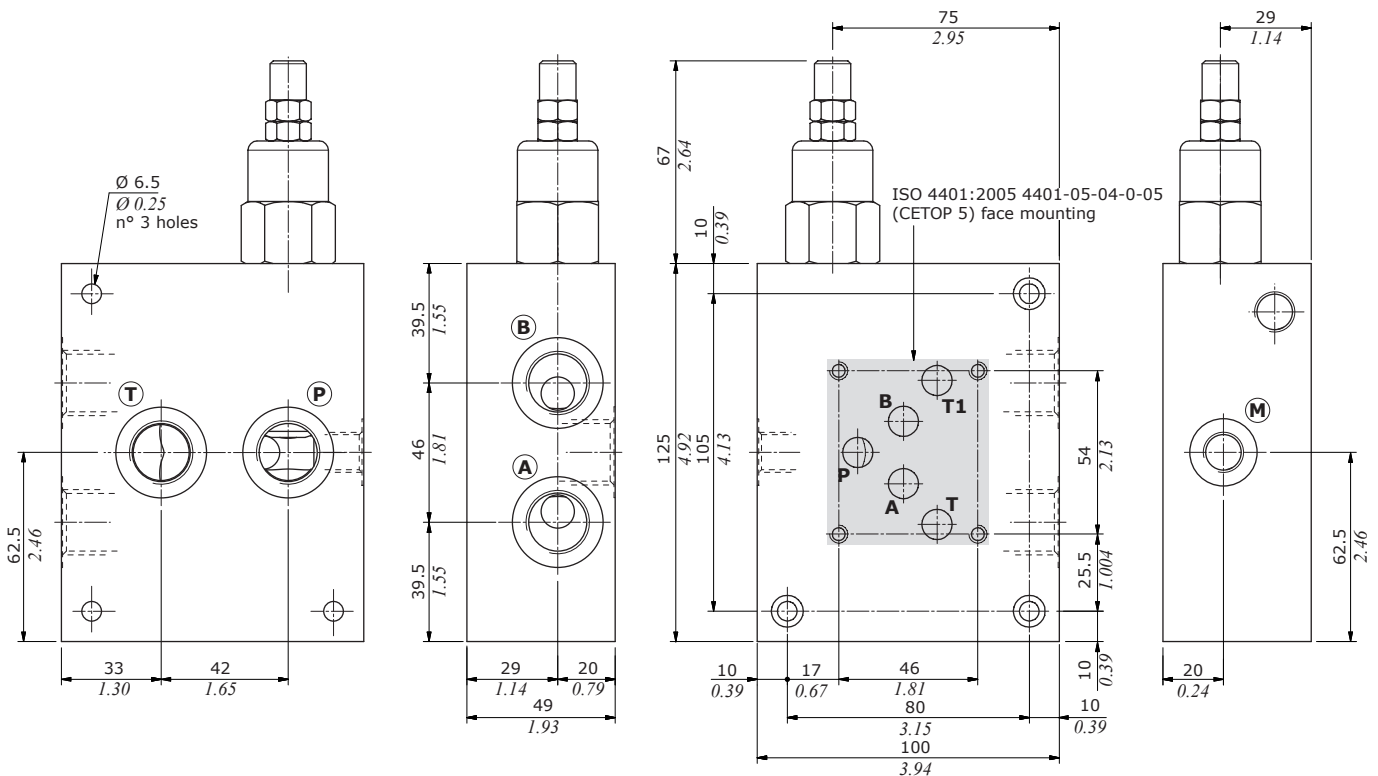

Ordering codes and description composition

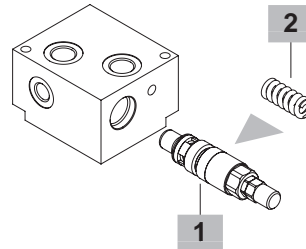
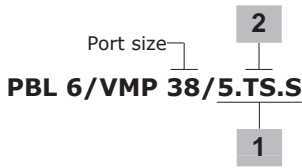

PBL complete valves

With direct acting valves; standard setting is referred to 5 l/min (1.32 US gpm)

Configuration with G3/8 standard thread and ISO 4401:2005 4401-03-02-0-05 (CETOP 3) face mounting

TYPE: **PBL 6/VMP 38/5.TS.S** CODE: 1114021102
DESCRIPTION: Aluminium body, range 50-220 bar (725-3200 psi).
Standard setting 160 bar (2300 psi)

TYPE: **PBL 6/VMP 38/5.TS.S/ac** CODE: 1114022101
DESCRIPTION: Steel body, as previous one

TYPE: **PBL 6/VMP 38/5Y.TS.S** CODE: 1114021123
DESCRIPTION: Aluminium body, range 140-190 bar (2030-2750 psi).
Standard setting 150 bar (2200 psi)

Configuration with G1/2 standard thread and ISO 4401:2005 4401-05-04-0-05 (CETOP 5) face mounting

TYPE: **PBL 10/VMP 12/10.TS.S** CODE: 1114031102
DESCRIPTION: Aluminium body, range 50-220 bar (725-3200 psi).
Standard setting 160 bar (2300 psi)

TYPE: **PBL 10/VMP 12/10.TS.S/ac** CODE: 1114032101
DESCRIPTION: Steel body, as previous one

Configuration with SAE8 standard thread and ISO 4401:2005 4401-03-02-0-05 (CETOP 3) face mounting

TYPE: **PBL 6/VMP 38/5.TS.S/SAE** CODE: 1114021200
DESCRIPTION: Aluminium body, range 50-220 bar (725-3200 psi).
Standard setting 160 bar (2300 psi)

For other steel body configurations, SAE thread and configurations with FPM (Viton) seals please contact our Sales Dpt.

1 Direct acting pressure relief valves

Standard setting is referred to 5 l/min (1.32 US gpm)

TYPE	CODE	DESCRIPTION
------	------	-------------

For G3/8 and SAE8 ports configuration

VMP 5/TS.S	1100520400	Setting range 50-220 bar (725-3200 psi) Standard setting 160 bar (2300 psi)
VMP 5Y/TS.S	1100520406	Setting range 140-190 bar (2030-2755 psi) Standard setting 150 bar (2200 psi)

For G1/2 ports configuration

VMP 10/TS.S	1100530400	Setting range 50-220 bar (725-3200 psi)
--------------------	------------	---

2 Pressure setting spring

TYPE	CODE	DESCRIPTION
------	------	-------------

For VMP 5 valve

TB	3MOL314311	Setting range 5-40 bar (72.5-580 psi)
TV	3MOL314330	Setting range 20-80 bar (290-1160 psi)
TS	3MOL315330	Setting range 50-220 bar (725-3200 psi)
TR	3ML1143600	Setting range 180-350 bar (2600-5100 psi)

For VMP 5Y valve

TB	3MOL314311	Setting range 5-80 bar (72.5-1160 psi)
TV	3MOL314330	Setting range 40-150 bar (580-2200 psi)
TS	3ML1143400	Setting range 140-190 bar (2600-5100 psi)
TR	3MOL315330	Setting range 180-350 bar (2600-5100 psi)

For VMP 10 valve

TB	3MOL316410	Setting range 5-40 bar (72.5-580 psi)
TV	3ML1154300	Setting range 20-80 bar (290-1160 psi)
TS	3MOL317420	Setting range 50-220 bar (725-3200 psi)
TR	3MOL317440	Setting range 180-350 bar (2600-5100 psi)

Rating diagrams

PBL 6/VMP 38 pressure vs. flow
Std. setting @ 5 l/min (1.32 US gpm)

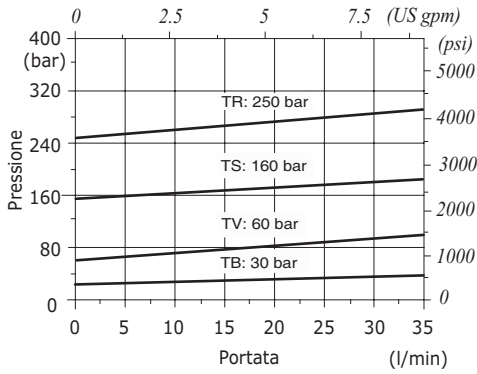

PBL 6/VMP 38/5Y pressure vs. flow
Std. setting @ 5 l/min (1.32 US gpm)

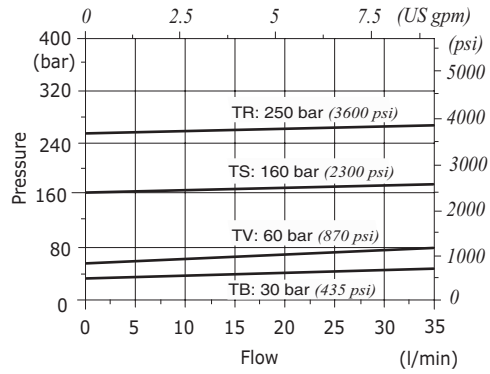

PBL 10/VMP 12 pressure vs. flow
Std. setting @ 5 l/min (1.32 US gpm)

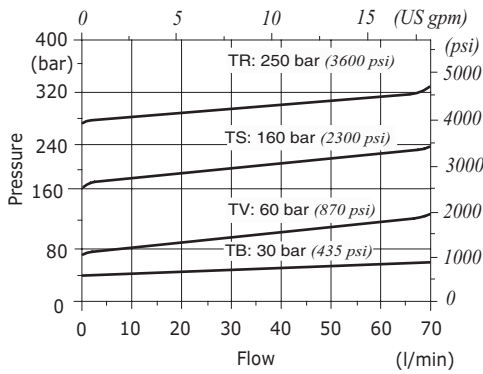



Type VAIL pressure relief valves

- Double antishock direct acting relief valve

Technical specifications and diagrams are measured with mineral oil of 46 cSt viscosity at 40°C (104°F) temperature.

	VAIL 5-38	VAIL 5-12	VAIL 10-12	VAIL 10-34	VAIL 20-34	VAIL 20-100	
Nominal flow	25 l/min (6.6 US gpm)	35 l/min (9.2 US gpm)	70 l/min (18.4 US gpm)	70 l/min (18.4 US gpm)	100 l/min (26.4 US gpm)	120 l/min (31.7 US gpm)	
Max. pressure	Aluminium body = 210 bar (3050 psi) Steel body = 350 bar (5100 psi)						
Oil leakage at 80% of max. setting	3 cm ³ /min (0.18 in ³ /min)						
Fluid	mineral based oil						
Viscosity	from 10 to 200 cSt						
Max. level of contamination	18/16/13 ISO4406						
Fluid temperature	with NBR seals from -20°C (-4°F) to 80°C (176°F)						
Environmental temp. for working conditions	from -40°C (-40°F) to 100°C (212°F)						
Weight	<i>aluminium</i>	0.67 kg (1.48 lb)	0.69 kg (1.52 lb)	1.12 kg (2.47 lb)	1.10 kg (2.43 lb)	1.87 kg (4.12 lb)	1.85 kg (4.08 lb)
	<i>steel</i>	1.31 kg (2.89 lb)	1.35 kg (2.98 lb)	2.20 kg (4.85 lb)	2.11 kg (4.65 lb)	3.55 kg (7.83 lb)	3.93 kg (8.66 lb)

NOTE - For different conditions, please contact Walvoil Sales Dpt.

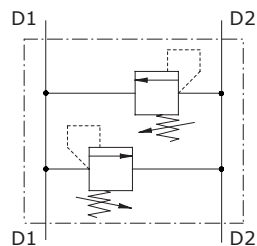

Dimensions

Valve type	All ports
VAIL 5-38	G3/8
VAIL 5-12	G1/2
VAIL 10-12	G1/2
VAIL 10-34	G3/4
VAIL 20-34	G3/4
VAIL 20-100	G1
Valve type	All ports
VAIL 5-38/SAE	SAE8
VAIL 5-12/SAE	SAE10
VAIL 10-12/SAE	SAE10
VAIL 10-34/SAE	SAE12
VAIL 20-34/SAE	SAE12
VAIL 20-100/SAE	SAE16

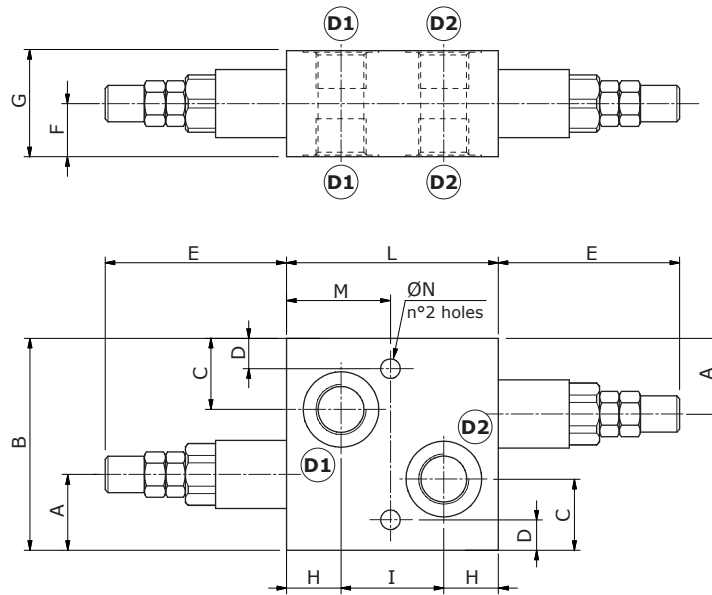

Dimensions are in mm-in

Valve type	A	B	C	D	E	F	G	H	I	L	M	ØN
VAIL 5-38 VAIL 5-38/SAE	25-0.98	70-2.75	23.5-0.92	10-0.39	60-4.92	17.5-0.69	35-1.38	18-0.70	34-1.34	70-2.75	35-1.38	6.5-0.25
VAIL 5-12 VAIL 5-12/SAE	25-0.98	70-2.75	23.5-0.92	10-0.39	60-4.92	17.5-0.69	35-1.38	18-0.70	39-1.53	75-2.95	37.5-1.48	6.5-0.25
VAIL 10-12 VAIL 10-12/SAE	29-1.41	82-3.23	25-0.98	8.5-0.33	67-2.64	20-0.79	40-1.57	20-0.79	50-1.97	90-3.54	45-1.77	8.5-0.33
VAIL 10-34 VAIL 10-34/SAE	29-1.41	82-3.23	25-0.98	8.5-0.33	67-2.64	20-0.79	40-1.57	20-0.79	50-1.97	90-3.54	45-1.77	8.5-0.33
VAIL 20-34 VAIL 20-34/SAE	31.5-1.84	95-3.74	30.5-1.2	10-0.39	76.5-3.01	25-0.98	50-1.97	22-0.87	56-2.20	100-3.93	50-1.97	8.5-0.33
VAIL 20-100 VAIL 20-100/SAE	31.5-1.84	95-3.74	30.5-1.2	10-0.39	76.5-3.01	25-0.98	50-1.97	32-1.26	56-2.20	120-4.72	60-2.36	8.5-0.33

Ordering codes and description composition

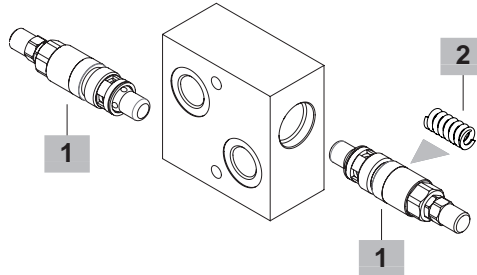
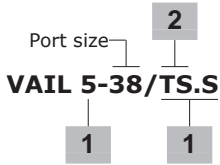

VAIL complete valves

With direct acting valves: standard setting 160 bar @ 5 l/min (2300 psi at 1.32 US gpm)

TYPE	CODE	DESCRIPTION
Configuration with G3/8 standard thread		
VAIL 5-38/TS.S	1140021102	Aluminium body, range 50-220 bar (725-3200 psi)
VAIL 5-38/TS.S/ac	1140022100	Steel body, as previous one
Configuration with G1/2 standard thread		
VAIL 5-12/TS.S	1140021152	Aluminium body, setting range 50-220 bar (725-3200 psi)
VAIL 5-12/TS.S/ac	1140022150	Steel body, as previous one
VAIL 10-12/TS.S	1140031102	Aluminium body, setting range 50-220 bar (725-3200 psi)
VAIL 10-12/TS.S/ac	1140032101	Steel body, as previous one
Configuration with G3/4 standard thread		
VAIL 10-34/TS.S	1140031152	Aluminium body, setting range 50-220 bar (725-3200 psi)
VAIL 10-34/TS.S/ac	1140032150	Steel body, as previous one
VAIL 20-34/TS.S	1140041102	Aluminium body, setting range 50-220 bar (725-3200 psi)
VAIL 20-34/TS.S/ac	1140042101	Steel body, as previous one
Configuration with G1" standard thread		
VAIL 20-100/TS.S	1140041152	Aluminium body, setting range 50-220 bar (725-3200 psi)
VAIL 20-100/TS.S/ac	1140042151	Steel body, as previous one
Configuration with SAE8 standard thread		
VAIL 5-38/TS.S/SAE	1140021200	Aluminium body, range 50-220 bar (725-3200 psi)
Configuration with SAE10 standard thread		
VAIL 5-12/TS.S/SAE	1140021250	Aluminium body, setting range 50-220 bar (725-3200 psi)
VAIL 10-12/TS.S	1140031200	Aluminium body, setting range 50-220 bar (725-3200 psi)
Configuration with SAE12 standard thread		
VAIL 10-34/TS.S/SAE	1140031250	Aluminium body, setting range 50-220 bar (725-3200 psi)
VAIL 20-34/TS.S/SAE	1140041200	Aluminium body, setting range 50-220 bar (725-3200 psi)
Configuration with SAE16 standard thread		
VAIL 20-100/TS.S/SAE	1140041250	Aluminium body, setting range 50-220 bar (725-3200 psi)

For other steel body configurations, SAE thread and configurations with FPM (Viton) seals please contact our Sales Dpt.

1 Direct acting pressure relief valves

Standard setting 160 bar @ 5 l/min (2300 psi at 1.32 US gpm)

TYPE	CODE	DESCRIPTION
For G1/2 and G3/4 ports configuration		
VMP 5/TS.S	1100520400	Setting range 50-220 bar (725-3200 psi)
VMP 10/TS.S	1100530400	Setting range 50-220 bar (725-3200 psi)
For G3/4 and G1" ports configuration		
VMP 20/TS.S	1100540400	Setting range 50-220 bar (725-3200 psi)

2 Pressure setting spring

CODE	TYPE	DESCRIPTION
For VMP 5 valve		
TB	3MOL314311	Setting range 5-40 bar (72.5-580 psi)
TV	3MOL314330	Setting range 20-80 bar (290-1160 psi)
TS	3MOL315330	Setting range 50-220 bar (725-3200 psi)
TR	3ML1143600	Setting range 180-350 bar (2600-5100 psi)
For VMP 10 valve		
TB	3ML1154100	Setting range 5-40 bar (72.5-580 psi)
TV	3ML1154300	Setting range 20-80 bar (290-1160 psi)
TS	3ML1164200	Setting range 50-220 bar (725-3200 psi)
TR	3ML1164400	Setting range 180-350 bar (2600-5100 psi)
For VMP 20 valve		
TB	3MOL316410	Setting range 5-40 bar (72.5-580 psi)
TV	3ML1154300	Setting range 20-80 bar (290-1160 psi)
TS	3MOL317420	Setting range 50-220 bar (725-3200 psi)
TR	3MOL317440	Setting range 180-350 bar (2600-5100 psi)

Rating diagrams

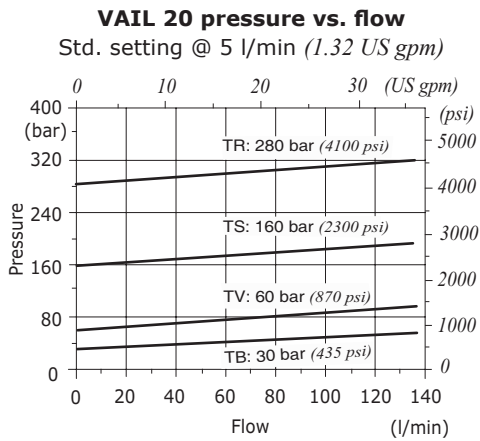
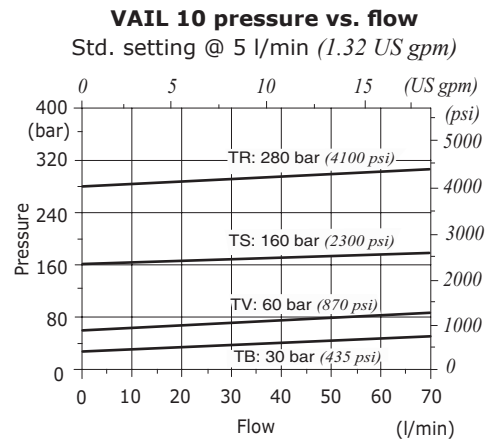
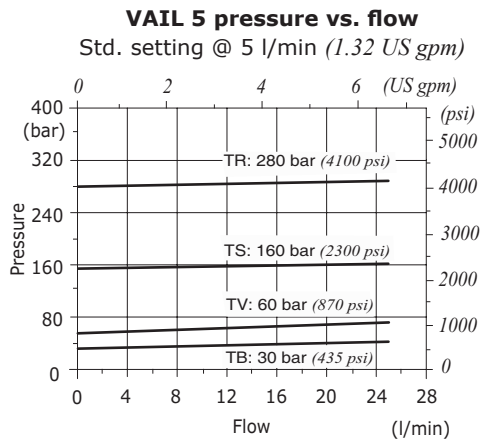

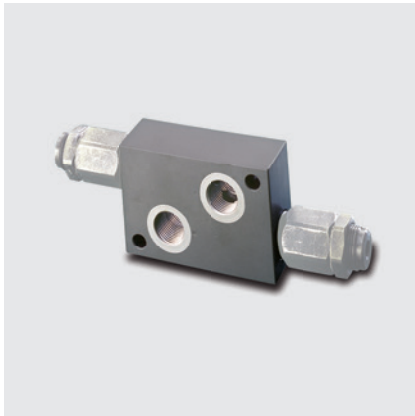

Type VADDL pressure relief valves

- Double antishock differential acting relief valve

Technical specifications and diagrams are measured with mineral oil of 46 cSt viscosity at 40°C (104°F) temperature.

	VADDL 38	VADDL 12	VADDL 34	VADDL 100	
Nominal flow	35 l/min (9.2 US gpm)	60 l/min (16 US gpm)	120 l/min (31.7 US gpm)	180 l/min (47.6 US gpm)	
Max. pressure	Aluminium body = 210 bar (3050 psi) Steel body = 350 bar (5100 psi)				
Oil leakage at 80% of max. setting	0.5 cm ³ /min (0.03 in ³ /min)				
Fluid	mineral based oil				
Viscosity	from 10 to 200 cSt				
Max. level of contamination	18/16/13 ISO4406				
Fluid temperature	with NBR seals from -20°C (-4°F) to 80°C (176°F) with FPM seals from -20°C (-4°F) to 100°C (212°F)				
Environmental temp. for working conditions	from -40°C (-40°F) to 100°C (212°F)				
Weight	aluminium	0.88 kg (1.94 lb)	1.17 kg (2.58 lb)	1.93 kg (4.25 lb)	2.29 kg (5.05 lb)
	steel	1.53 kg (3.37 lb)	2.04 kg (4.50 lb)	4.77 kg (10.51 lb)	4.16 kg (9.17 lb)

NOTE - For different conditions, please contact Walvoil Sales Dpt.

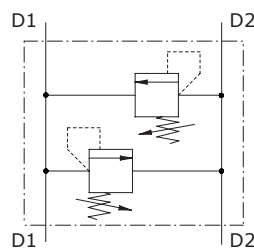

Dimensions

Valve type	All ports
VADDL 38	G3/8
VADDL 12	G1/2
VADDL 34	G3/4
VADDL 100	G1

Valve type	All ports
VADDL 38/SAE	SAE8
VADDL 12/SAE	SAE10
VADDL 34/SAE	SAE12
VADDL 100/SAE	SAE16

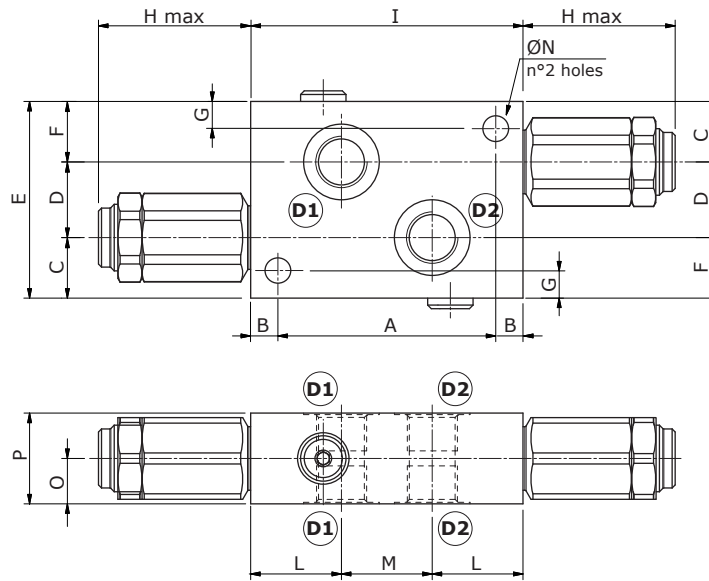

Dimensions are in mm-in

Valve type	A	B	C	D	E	F	G	H max	I	L	M	ØN	O	P
VADDL 38 VADDL 38/SAE	72-2.83	9-0.35	20-0.79	25-0.98	65-2.56	20-0.79	9-0.35	57.7-2.27	90-3.54	30-1.18	30-1.18	8.5-0.33	15-0.59	30-1.18
VADDL 12 VADDL 12/SAE	80-3.15	10-0.39	21-0.82	27-1.06	70-2.75	22-0.87	10-0.39	56.2-2.21	100-3.94	31-1.22	38-1.50	8.5-0.33	17.5-0.69	35-1.38
VADDL 34 VADDL 34/SAE	90-3.54	10-0.39	31-1.22	32-1.26	90-3.54	27-1.06	10-0.39	68.8-2.71	110-4.33	36-1.42	38-1.50	8.5-0.33	20-0.79	40-1.57
VADDL 100 VADDL 100/SAE	90-3.54	10-0.39	34-1.34	38-1.50	100-3.94	28-1.10	10-0.39	68.8-2.71	110-4.33	30-1.18	50-1.97	8.5-0.33	25-0.98	50-1.97

Ordering codes and description composition

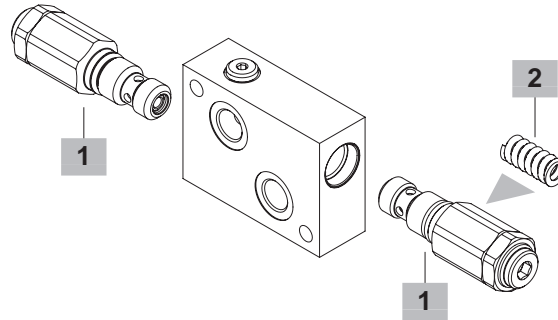
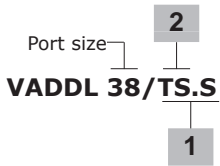

VADDL complete valves

Differential type valve configuration

Standard setting 150 bar @ 5 l/min (2100 psi at 1.32 US gpm)

TYPE	CODE	DESCRIPTION
Configuration with G3/8 standard thread		
VADDL 38/TS.S	1150021102	Aluminium body, setting range 5-210 bar (72.5-3045 psi)
VADDL 38/TS.S/ac	1150022100	Steel body, as previous one
Configuration with G1/2 standard thread		
VADDL 12/TS.S	1150031102	Aluminium body, setting range 5-210 bar (72.5-3045 psi)
VADDL 12/TS.S/ac	1150032100	Steel body, as previous one
Configuration with G3/4 standard thread		
VADDL 34/TS.S	1150041102	Aluminium body, setting range 5-210 bar (72.5-3045 psi)
VADDL 34/TS.S/ac	1150042101	Steel body, as previous one
Configuration with G1" standard thread		
VADDL 100/TS.S	1150051102	Aluminium body, setting range 5-210 bar (72.5-3045 psi)
VADDL 100/TS.S/ac	1150052100	Steel body, as previous one
Configuration with SAE8 standard thread		
VADDL 38/TS.S/SAE	1150021200	Aluminium body, setting range 5-210 bar (72.5-3045 psi)
Configuration with SAE10 standard thread		
VADDL 12/TS.S/SAE	1150031201	Aluminium body, setting range 5-210 bar (72.5-3045 psi)
Configuration with SAE12 standard thread		
VADDL 34/TS.S/SAE	1150041200	Aluminium body, setting range 5-210 bar (72.5-3045 psi)
Configuration with SAE16 standard thread		
VADDL 100/TS.S/SAE	1150051200	Aluminium body, setting range 5-210 bar (72.5-3045 psi)

For other steel body configurations, SAE thread and configurations with FPM (Viton) seals, please contact our Sales Dpt.

1 Direct acting pressure relief valves

Standard setting 150 bar @ 5 l/min (2100 psi at 1.32 US gpm)

TYPE	CODE	DESCRIPTION
For G3/8 ports configuration		
VMPD 38/TS.S	1120020402	Setting range 5-210 bar (72.5-3050 psi)
For G1/2 ports configuration		
VMPD 12/TS.S	1120030402	Setting range 5-210 bar (72.5-3050 psi)
For G3/4 and G1" ports configuration		
VMPD 34/TS.S	1120040402	Setting range 5-210 bar (72.5-3050 psi)

2 Pressure setting spring

TYPE	CODE	DESCRIPTION
For VMPD 38 valve		
TS	3ML1144000	Setting range 5-210 bar (72.5-3050 psi)
TR	3ML1144001	Setting range 50-350 bar (725-5100 psi)
For VMPD 12 valve		
TS	3ML1164000	Setting range 5-210 bar (72.5-3050 psi)
TR	3ML1164001	Setting range 50-350 bar (725-5100 psi)
For VMPD 34 valve		
TS	3ML1194500	Setting range 5-210 bar (72.5-3050 psi)
TR	3ML1194501	Setting range 50-350 bar (725-5100 psi)

Rating diagrams

VADDL 38 pressure drop vs. flow
Std. setting @ 5 l/min (1.32 US gpm)

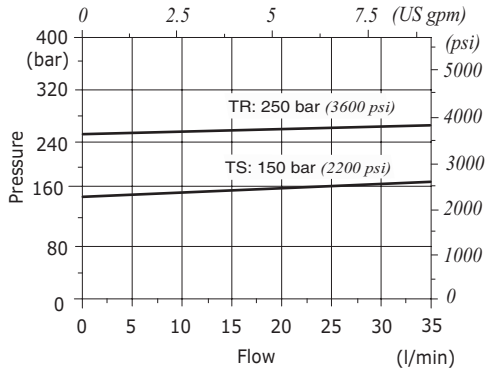

VADDL 12 pressure drop vs. flow
Std. setting @ 5 l/min (1.32 US gpm)

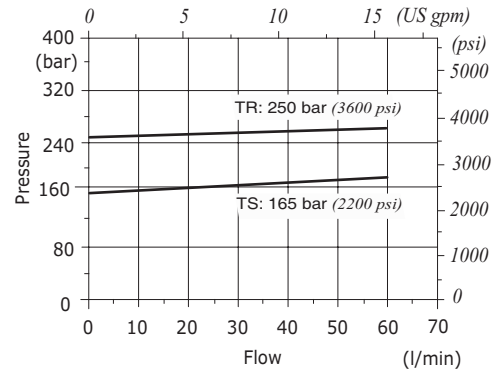

VADDL 34-100 pressure drop vs. flow
Std. setting @ 5 l/min (1.32 US gpm)

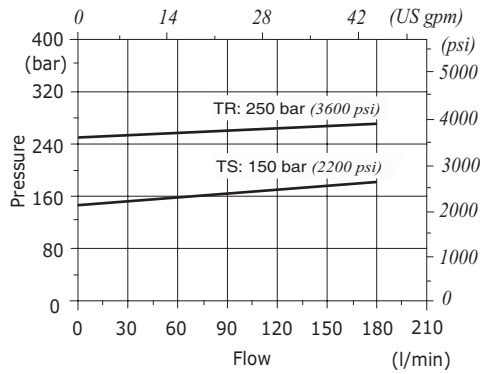

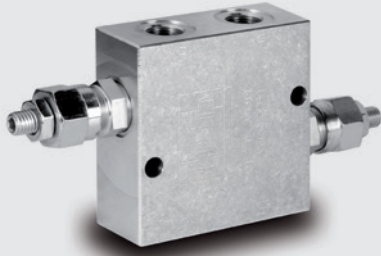

Type VBDC..35 - VBDC..80 pressure relief valves

- Dual cross relief valve

Technical specifications and diagrams are measured with mineral oil of 46 cSt viscosity at 40°C (104°F) temperature.

	VBDC..3502	VBDC..3503	VBDC..8003	VBDC..8004	
Nominal flow	35 l/min (9.2 US gpm)	35 l/min (9.2 US gpm)	80 l/min (21 US gpm)	80 l/min (21 US gpm)	
Max. pressure	Aluminium body = 210 bar (3050 psi) Steel body = 350 bar (5100 psi)				
Fluid	mineral based oil				
Viscosity	from 10 to 200 cSt				
Max. level of contamination	18/16/13 ISO4406				
Fluid temperature	with NBR seals from -20°C (-4°F) to 80°C (176°F)				
Environmental temp. for working conditions	from -40°C (-40°F) to 100°C (212°F)				
Weight	<i>alum.</i>	0.80 kg (1.76 lb)	0.80 kg (1.76 lb)	1.65 kg (3.64 lb)	1.60 kg (3.53 lb)
	<i>steel</i>	2.10 kg (4.63 lb)	2 kg (4.41 lb)	3.40 kg (7.49 lb)	3.30 kg (7.27 lb)

NOTE - For different conditions, please contact Walvoil Sales Dpt.

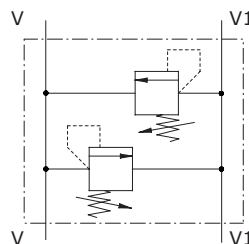

Dimensions

VBDC..35

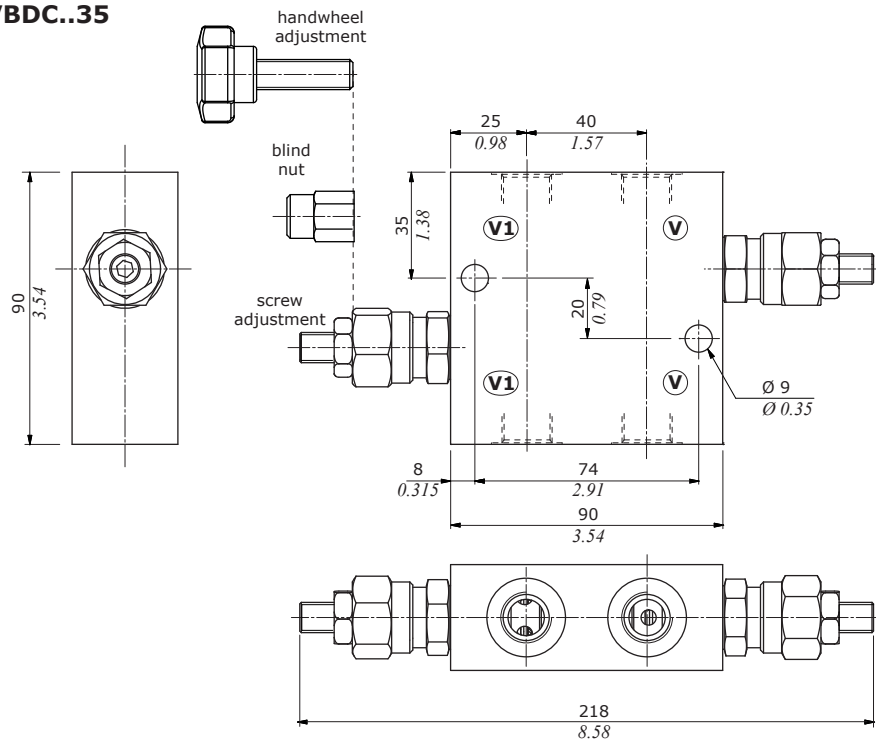

Valve type	All ports
VBDC..3502	G3/8
VBDC..3503	G1/2

Dimensions are in mm-in

VBDC..80

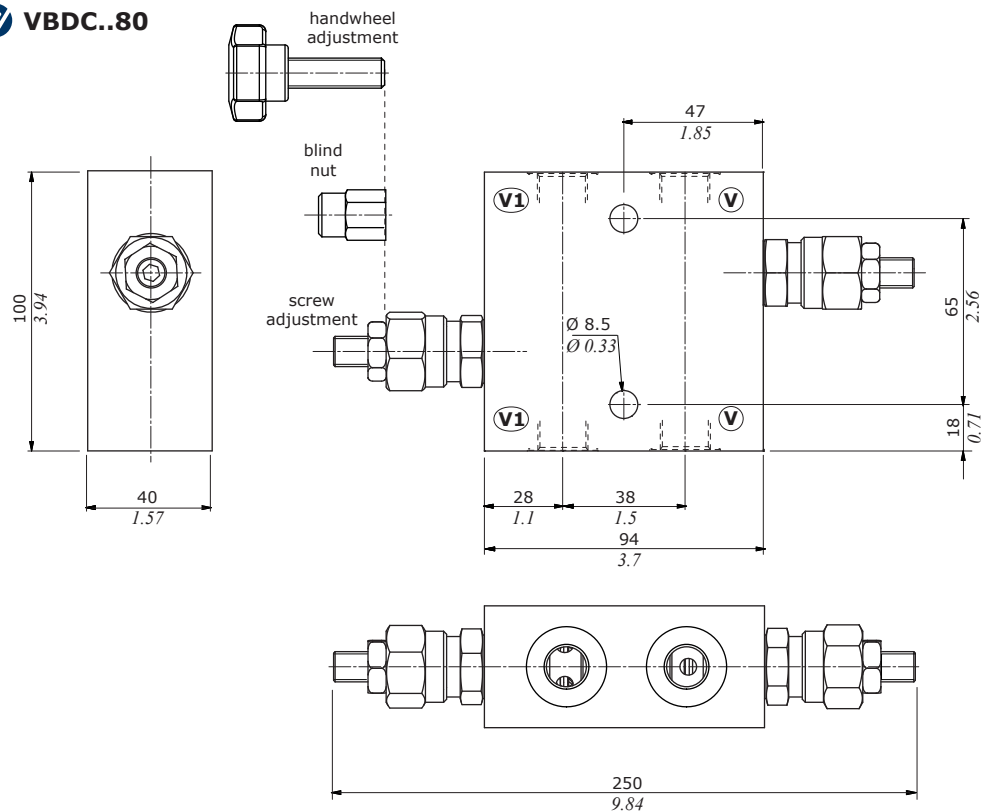

Valve type	All ports
VBDC..8003	G1/2
VBDC..8004	G3/4

Dimensions are in mm-in

Ordering codes and description composition

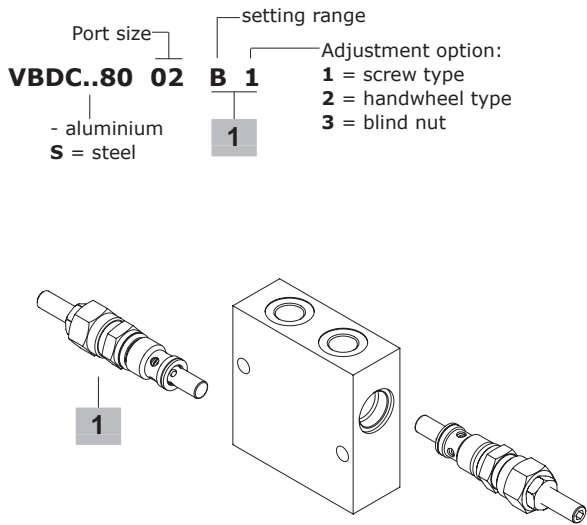

Type	Setting range bar (psi)	Std. setting bar (psi)
VMD..35	A 5-50 (72.5-725)	40 (580)
	B 40-210 (580-3050)	100 (1450)
	C 100-350 (1450-5100)	100 (1450)
VMD..80	A 5-50 (72.5-725)	40 (580)
	B 20-260 (290-3770)	100 (1450)
	C 120-350 (1750-5100)	120 (1740)

VBDC..35 - VBDC..80 complete valves

Standard setting 100 bar @ 3 l/min (1450 psi @ 0.79 US gpm)

TYPE	CODE	DESCRIPTION
Configuration with G3/8 standard thread		
VBDC3502B1	1145221100	Aluminium body, setting range 40-210 bar (580-3045 psi)
VBDCS3502B1	1145222100	Steel body, setting range 40-210 bar (580-3045 psi)
Configuration with G1/2 standard thread		
VBDC3503B1	1145221101	Aluminium body, setting range 40-210 bar (580-3045 psi)
VBDCS3503B1	1145222101	Steel body, setting range 40-210 bar (580-3045 psi)
Configuration with G3/4 standard thread		
VBDC8004B1	1145231100	Aluminium body, setting range 20-260 bar (290-3770 psi)
VBDCS8004C1	1145232100	Steel body, setting range 120-350 bar (1740-5070 psi)

For different configurations and SAE thread please contact our Sales Dpt.

1 Direct acting pressure relief valves

Standard setting 100 bar @ 3 l/min (1450 psi @ 0.79 US gpm)

TYPE	CODE	DESCRIPTION
For VBDC..35 valve		
VMDC35B1(M20X1,5)	1100220400	Screw adjustment from 40 to 210 bar (580-3050 psi)
For VBDC..80 valve		
VMDC80B1(M26X1,5)	1100230400	Screw adjustment from 40 to 260 bar (580-3770 psi)

Rating diagrams

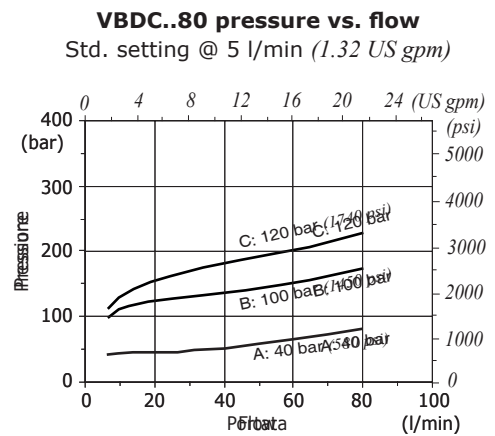
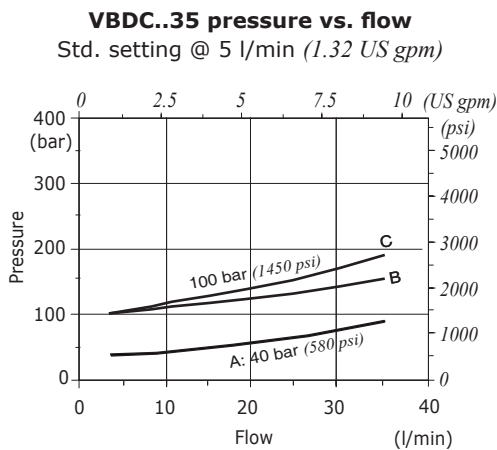



Type VAIL/VA pressure relief valves

- Double antishock direct acting relief valve with anticavitation

Technical specifications and diagrams are measured with mineral oil of 46 cSt viscosity at 40°C (104°F) temperature.

	VAIL/VA 12	VAIL/VA 34
Nominal flow	35 l/min (9.2 US gpm)	80 l/min (21 US gpm)
Max. pressure	Aluminium body = 210 bar (3050 psi) Steel body = 350 bar (5100 psi)	
Oil leakage at 80% of max. setting	6 cm ³ /min (0.37 in ³ /min)	
Fluid	mineral based oil	
Viscosity	from 10 to 200 cSt	
Max. level of contamination	18/16/13 ISO4406	
Fluid temperature	with NBR seals from -20°C (-4°F) to 80°C (176°F) with FPM seals from -20°C (-4°F) to 100°C (212°F)	
Environmental temp. for working conditions	from -40°C (-40°F) to 100°C (212°F)	
Weight	aluminium	2.48 kg (5.47 lb)
	steel	3.49 kg (7.69 lb)
		2.23 kg (4.92 lb)
		4.47 kg (9.85 lb)

NOTE - For different conditions, please contact Walvoil Sales Dpt.

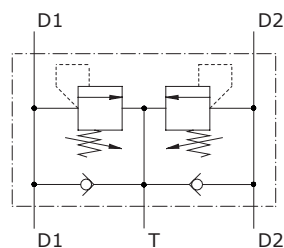

Dimensions

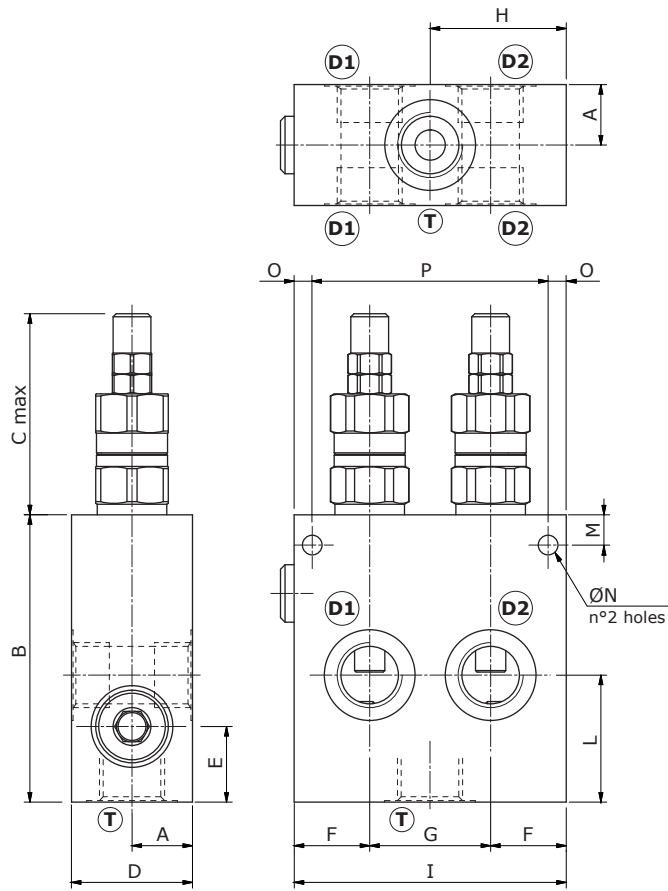

Valve type	All ports
VAIL/VA 12	G1/2
VAIL/VA 34	G3/4
Valve type	All ports
VAIL/VA 12/SAE	SAE10
VAIL/VA 34/SAE	SAE12

Dimensions are in mm-in

Valve type	A	B	C	D	E	F	G	H	I	L	M	ØN	O	P
VAIL/VA 12 VAIL/VA 12/SAE	20-0.79	95-3.74	68-2.68	40-1.57	25-0.98	25-0.98	40-1.57	45-1.77	90-3.54	42-1.65	10-0.39	6.5-0.25	6-0.24	78-3.07
VAIL/VA 34 VAIL/VA 34/SAE	25-0.98	110-4.33	82.5-3.25	50-1.97	24-0.94	29-1.14	52-2.05	55-2.05	110-4.33	47-1.85	10-0.39	8.5-0.33	8-0.31	94-3.70

Ordering codes and description composition

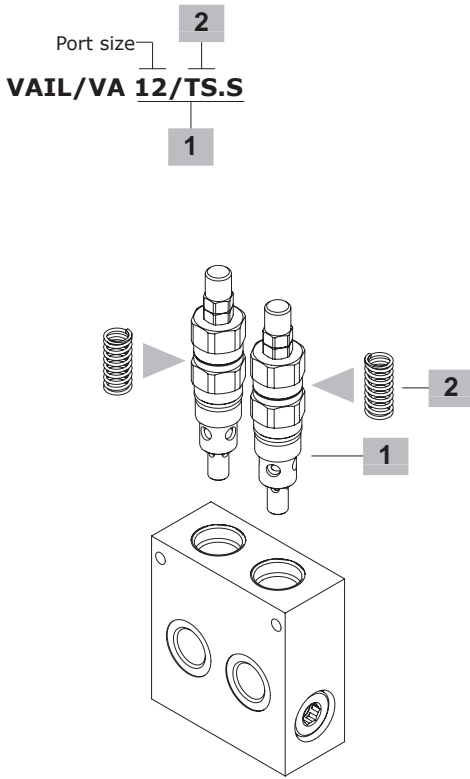

VAIL/VA complete valves

Aluminium body configuration, with direct acting valves; standard setting 140 bar @ 5 l/min (2030 psi at 1.32 US gpm)

TYPE	CODE	DESCRIPTION
------	------	-------------

Configuration with G1/2 standard thread

VAIL/VA 12/TS.S 1142031102 Range 50-200 bar (725-2900 psi)

VAIL/VA 12/TS.S/ac 1142032101 Range 50-200 bar (725-2900 psi)

Configuration with G3/4 standard thread

VAIL/VA 34/TS.S 1142041102 Range 50-200 bar (725-2900 psi)

VAIL/VA 34/TS.S/ac 1142042100 Range 50-200 bar (725-2900 psi)

Configuration with SAE10 standard thread

VAIL/VA 12/TS.S/SAE 1142031200 Range 50-200 bar (725-2900 psi)

Configuration with SAE12 standard thread

VAIL/VA 34/TS.S/SAE 1142041200 Range 50-200 bar (725-2900 psi)

1 Direct acting pressure relief valves

TYPE	CODE	DESCRIPTION
------	------	-------------

For G1/2 and SAE10 ports configuration

VMP 12/TS.S 1100030406 Setting range 50-200 bar (725-2900 psi)

For G3/4 and SAE12 ports configuration

VMP 34/TS.S 1100040406 Setting range 50-200 bar (725-2900 psi)

2 Pressure setting spring

TYPE	CODE	DESCRIPTION
------	------	-------------

For VAIL/VA 12 valve

TB 3ML1144600 Setting range 5-30 bar (72.5-435 psi)

TV 3ML1144601 Setting range 20-100 bar (290-1450 psi)

TS 3ML1144602 Setting range 50-200 bar (725-2900 psi)

TR 3ML1144603 Setting range 100-300 bar (1450-4350 psi)

For VAIL/VA 34 valve

TV 3ML1166804 Setting range 5-100 bar (72.5- 1450 psi)

TS 3ML1146800 Setting range 50-200 bar (725-2900 psi)

TR 3ML1166805 Setting range 100-300 bar (1450-4350 psi)

For other steel body configurations, SAE thread and configurations with FPM (Viton) seals, please contact our Sales Dpt.

Rating diagrams

VAIL/VA 12 pressure drop vs. flow
Std. setting @ 5 l/min (1.32 US gpm)

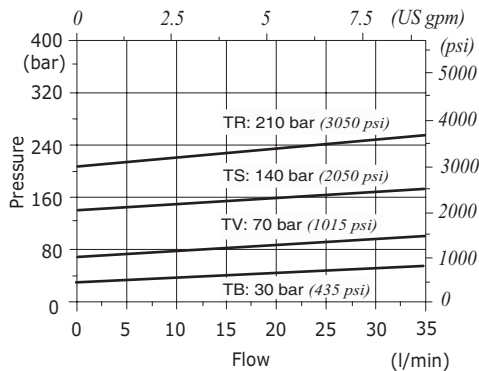

VAIL/VA 34 pressure drop vs. flow
Std. setting @ 5 l/min (1.32 US gpm)

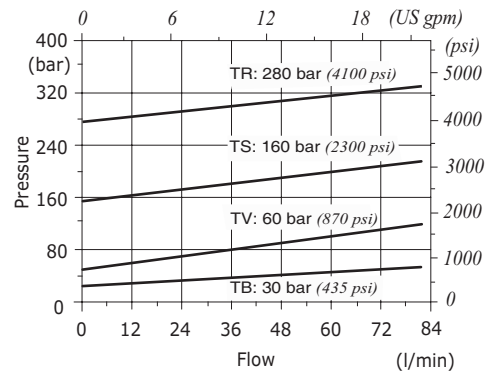



Type VMDACSV pressure relief valves

- Double antishock differential relief valve with anticavitation

Technical specifications and diagrams are measured with mineral oil of 46 cSt viscosity at 40°C (104°F) temperature.

	VMDACSV 02	VMDACSV 03
Nominal flow	45 l/min (11.9 US gpm)	70 l/min (18.5 US gpm)
Max. pressure	Steel body = 350 bar (5100 psi)	
Fluid	mineral based oil	
Viscosity	from 10 to 200 cSt	
Max. level of contamination	18/16/13 ISO4406	
Fluid temperature	with NBR seals from -20°C (-4°F) to 80°C (176°F)	
Environmental temperature for working conditions	from -40°C (-40°F) to 100°C (212°F)	
Weight	steel 1.96 kg (4.31 lb)	1.85 kg (4.08 lb)

NOTE - For different conditions, please contact Walvoil Sales Dpt.

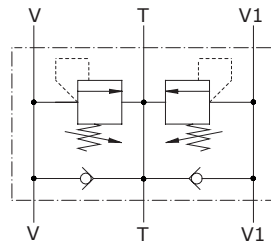

Dimensions

Valve type	All ports
VMDACSV02D	G3/8
VMDACSV03C	G1/2
VMDACSV03D	G1/2

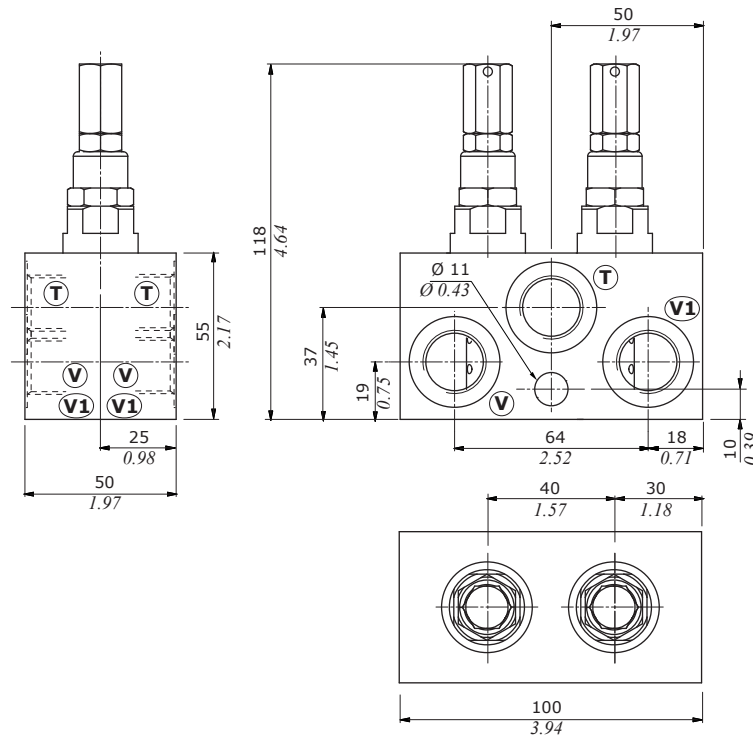

Ordering codes and description composition

Port size | Setting range
VMDACSV 03 C

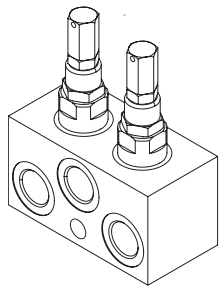

Spring type	Setting range bar (psi)	Std. setting bar (psi)
C	95-125 (1370-1800)	110 (1600)
D	125-160 (1800-2300)	140 (2030)

VMDACSV complete valves

TYPE	CODE	DESCRIPTION
Configuration with G3/8 standard thread		
VMDACSV02D	1152521100	Steel body, setting range 125-160 bar (1800-2300 psi), std setting 140 bar @ 5 l/min (2030 psi @ 1.32 US gpm)
Configuration with G1/2 standard thread		
VMDACSV03C	1152531100	Steel body, setting range 95-125 bar (1370-1800 psi), std setting 110 bar @ 5 l/min (1600 psi @ 1.32 US gpm)
VMDACSV03D	1152531101	Steel body, setting range 125-160 bar (1800-2300 psi), std setting 140 bar @ 5 l/min (2030 psi @ 1.32 US gpm)

For different configurations and SAE thread please contact our Sales Dpt.

Rating diagrams

VMDACSV02C pressure vs. flow
Std. setting @ 5 l/min (1.32 US gpm)

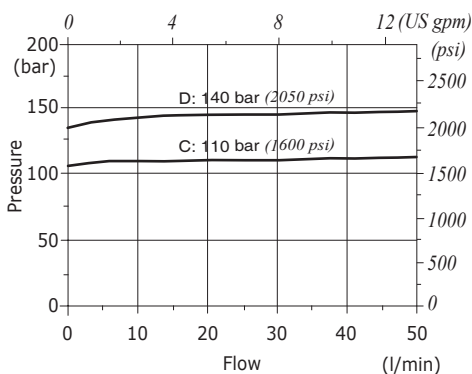

VMDACSV03C pressure vs. flow
Std. setting @ 5 l/min (1.32 US gpm)

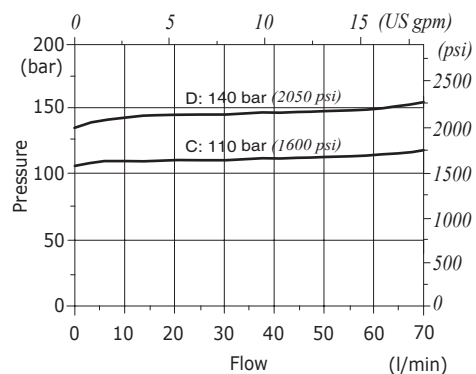



Type VADDL/VA pressure relief valves

- Double antishock differential acting relief valve with anticavitation

Technical specifications and diagrams are measured with mineral oil of 46 cSt viscosity at 40°C (104°F) temperature.

	VADDL/VA 38	VADDL/VA 12	VADDL/VA 34	VADDL/VA 100	
Nominal flow	35 l/min (9.2 US gpm)	60 l/min (16 US gpm)	120 l/min (31.7 US gpm)	180 l/min (47.6 US gpm)	
Max. pressure	Aluminium body = 210 bar (3050 psi) Steel body = 350 bar (5100 psi)				
Oil leakage at 80% of max. setting	0.50 cm ³ /min (0.03 in ³ /min)				
Fluid	mineral based oil				
Viscosity	from 10 to 200 cSt				
Max. level of contamination	18/16/13 ISO4406				
Fluid temperature	with NBR seals from -20°C (-4°F) to 80°C (176°F)				
Environmental temperature for working conditions	from -40°C (-40°F) to 100°C (212°F)				
Weight	aluminium	1.14 kg (2.51 lb)	1.58 kg (3.48 lb)	3.25 kg (7.16 lb)	3.57 kg (7.87 lb)
	steel	2.10 kg (4.63 lb)	3.10 kg (6.83 lb)	6.50 kg (14.33 lb)	7.78 kg (17.15 lb)

NOTE - For different conditions, please contact Walvoil Sales Dpt.

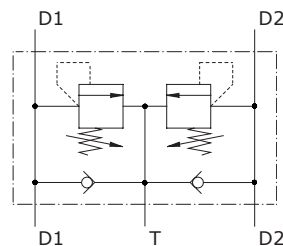

Dimensions

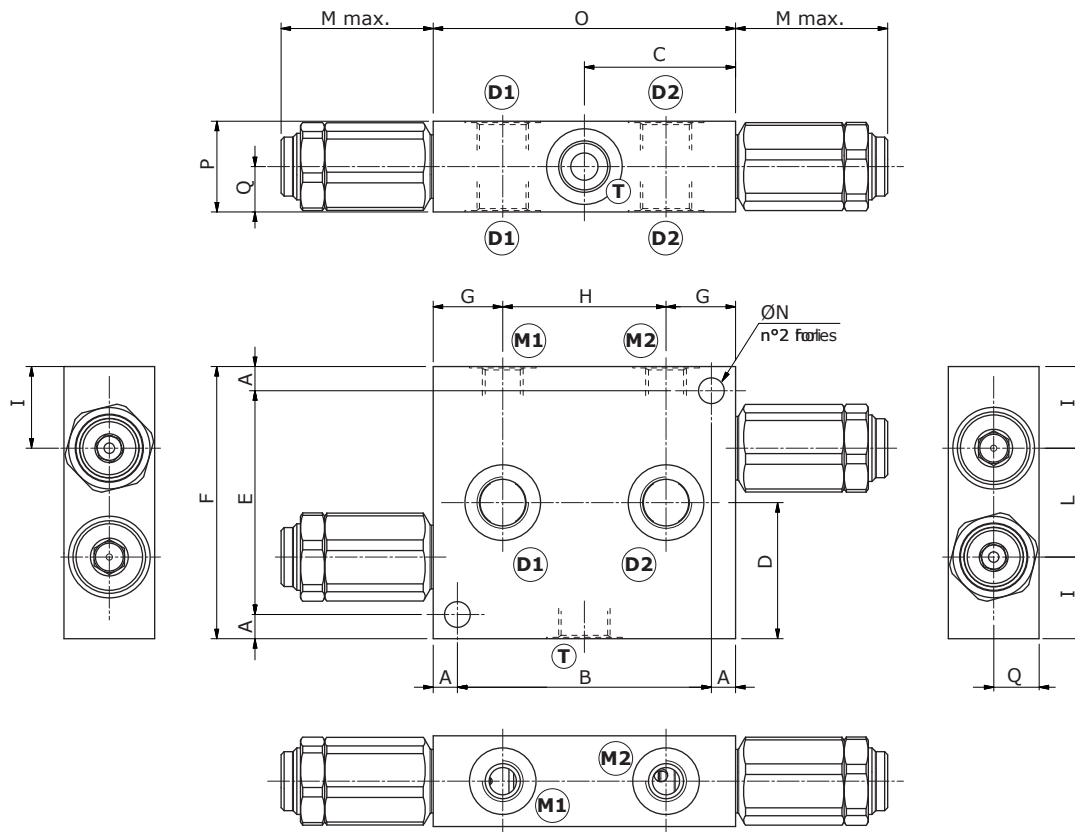

Valve type	D1	D2	T	M1	M2	Valve type	D1	D2	T	M1	M2
VADDL/VA 38	G3/8		G1/4			VADDL/VA 38/SAE	SAE8		SAE6		
VADDL/VA 12	G1/2		G1/4			VADDL/VA 12/SAE	SAE10		SAE6		
VADDL/VA 34	G3/4		G1/4			VADDL/VA 34/SAE	SAE12		SAE6		
VADDL/VA 100	G1"		G1/4			VADDL/VA 100/SAE	SAE16		SAE6		

Dimensions are in mm-in

Valve type	A	B	C	D max	E	F	G	H	I	L	M	ØN	O	P	Q
VADDL/VA 38 VADDL/VA 38/SAE	8-0.31	84-3.31	50-1.97	57.7-2.27	74-2.91	90-3.54	23-0.90	54-2.12	27-1.06	36-1.42	52-2.05	8.5-0.33	100-3.94	30-1.18	15-0.59
VADDL/VA 12 VADDL/VA 12/SAE	8-0.31	84-3.31	46-1.81	56.2-2.21	84-3.30	100-3.94	23-0.90	54-2.12	30-1.18	40-1.57	57-2.24	8.5-0.33	100-3.94	40-1.57	20-0.79
VADDL/VA 34 VADDL/VA 34/SAE	10-0.39	110-4.33	55-1.97	68.8-2.71	100-3.94	120-4.72	28-1.10	64-2.52	37-1.46	46-1.81	66-2.60	10.5-0.41	120-4.72	60-3.15	30-1.18
VADDL/VA 100 VADDL/VA 100/SAE	10-0.39	110-4.33	70-2.75	68.8-2.71	110-4.33	130-5.11	30-1.18	70-2.75	37-1.46	56-2.20	66-2.60	10.5-0.41	130-5.11	70-2.75	35-1.38

Ordering codes and description composition

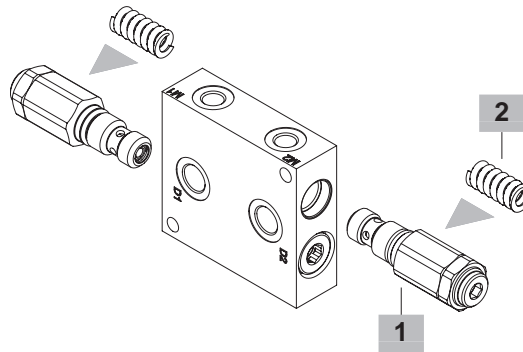
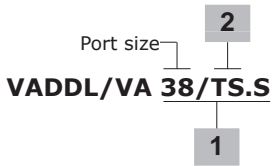

VADDL/VA complete valves

Differential type valve configuration

Standard setting 150 bar @ 5 l/min (2100 psi at 1.32 US gpm)

TYPE	CODE	DESCRIPTION
Configuration with G3/8 standard thread		
VADDL/VA 38/TS.S	1152021102	Aluminium body, setting range 5-210 bar (72.5-3045 psi)
VADDL/VA 38/TS.S/ac	1152022100	Steel body, as previous one
Configuration with G1/2 standard thread		
VADDL/VA 12/TS.S	1152031102	Aluminium body, setting range 5-210 bar (72.5-3045 psi)
VADDL/VA 12/TS.S/ac	1152032100	Steel body, as previous one
Configuration with G3/4 standard thread		
VADDL/VA 34/TS.S	1152041102	Aluminium body, setting range 5-210 bar (72.5-3045 psi)
VADDL/VA 34/TS.S/ac	1152042100	Steel body, as previous one
Configuration with G1" standard thread		
VADDL/VA 100/TS.S	1152051102	Aluminium body, setting range 5-210 bar (72.5-3045 psi)
VADDL/VA 100/TS.S/ac	1152052100	Steel body, as previous one
Configuration with SAE8 standard thread		
VADDL/VA 38/TS.S/SAE	1152021200	Aluminium body, setting range 5-210 bar (72.5-3045 psi)
Configuration with SAE10 standard thread		
VADDL/VA 12/TS.S/SAE	1152031200	Aluminium body, setting range 5-210 bar (72.5-3045 psi)
Configuration with SAE12 standard thread		
VADDL/VA 34/TS.S/SAE	1152041200	Aluminium body, setting range 5-210 bar (72.5-3045 psi)
Configuration with SAE16 standard thread		
VADDL/VA 100/TS.S/SAE	1152051200	Aluminium body, setting range 5-210 bar (72.5-3045 psi)

For other steel body configurations, SAE thread and configurations with FPM (Viton) seals, please contact our Sales Dpt.

1 Direct acting pressure relief valves

Standard setting 150 bar @ 5 l/min (2100 psi at 1.32 US gpm)

TYPE	CODE	DESCRIPTION
For G3/8 and SAE8 ports configuration		
VMPD 38/TS.S	1120020402	Setting range 5-210 bar (72.5-3050 psi)
For G1/2 and SAE10 ports configuration		
VMPD 12/TS.S	1120030402	Setting range 5-210 bar (72.5-3050 psi)
For G3/4, G1", SAE12 and SAE16 ports configuration		
VMPD 34/TS.S	1120040402	Setting range 5-210 bar (72.5-3050 psi)

2 Pressure setting spring

TYPE	CODE	DESCRIPTION
For VMPD 38 valve		
TS	3ML1144000	Spring for range 5-210 bar (72.5-3050 psi)
TR	3ML1144001	Spring for range 50-350 bar (725-5100 psi)
For VMPD 12 valve		
TS	3ML1164000	Spring for range 5-210 bar (72.5-3050 psi)
TR	3ML1164001	Spring for range 50-350 bar (725-5100 psi)
For VMPD 34 valve		
TS	3ML1194500	Spring for range 5-210 bar (72.5-3050 psi)
TR	3ML1194501	Spring for range 50-350 bar (725-5100 psi)

Rating diagrams

VADDL/VA 38 pressure vs. flow
Std. setting @ 5 l/min (1.32 US gpm)

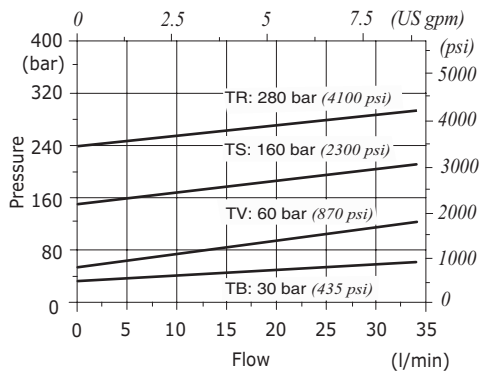

VADDL/VA 12 pressure vs. flow
Std. setting @ 5 l/min (1.32 US gpm)

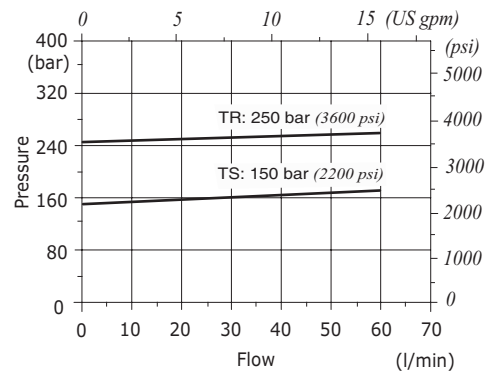

VADDL/VA 34-100 pressure vs. flow
Std. setting @ 5 l/min (1.32 US gpm)

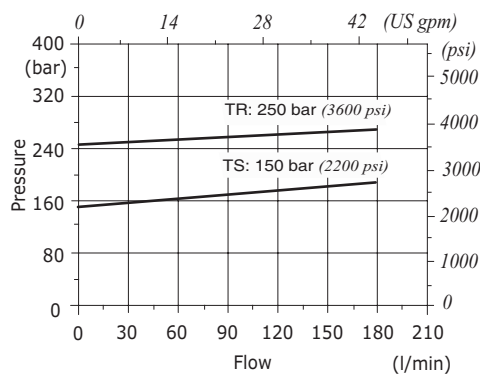



Type VAA/RU/DL pressure relief valves

- Antishock direct acting relief valve with anticavitation, with single adjustment

Technical specifications and diagrams are measured with mineral oil of 46 cSt viscosity at 40°C (104°F) temperature.

	VAA/RU/DL 38	VAA/RU/DL 12	VAA/RU/DL 34	VAA/RU/DL 100	
Nominal flow	35 l/min (9.2 US gpm)	60 l/min (16 US gpm)	120 l/min (31.7 US gpm)	180 l/min (47.6 US gpm)	
Max. pressure	Aluminium body = 210 bar (3050 psi) Steel body = 350 bar (5100 psi)				
Oil leakage at 80% of max. setting	0.75 cm ³ /min (0.04 in ³ /min)				
Fluid	mineral based oil				
Viscosity	from 10 to 200 cSt				
Max. level of contamination	18/16/13 ISO4406				
Fluid temperature	with NBR seals from -20°C (-4°F) to 80°C (176°F)				
Environmental temperature for working conditions	from -40°C (-40°F) to 100°C (212°F)				
Weight	aluminium	1.18 kg (2.60 lb)	1.15 kg (2.53 lb)	2.32 kg (5.11 lb)	3.95 kg (8.71 lb)
	steel	2.44 kg (5.38 lb)	2.38 kg (5.25 lb)	4.73 kg (10.43 lb)	8.12 kg (17.90 lb)

NOTE - For different conditions, please contact Walvoil Sales Dpt.

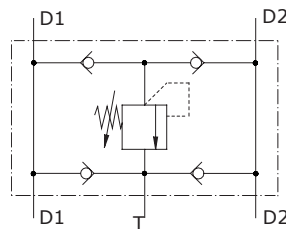

Dimensions

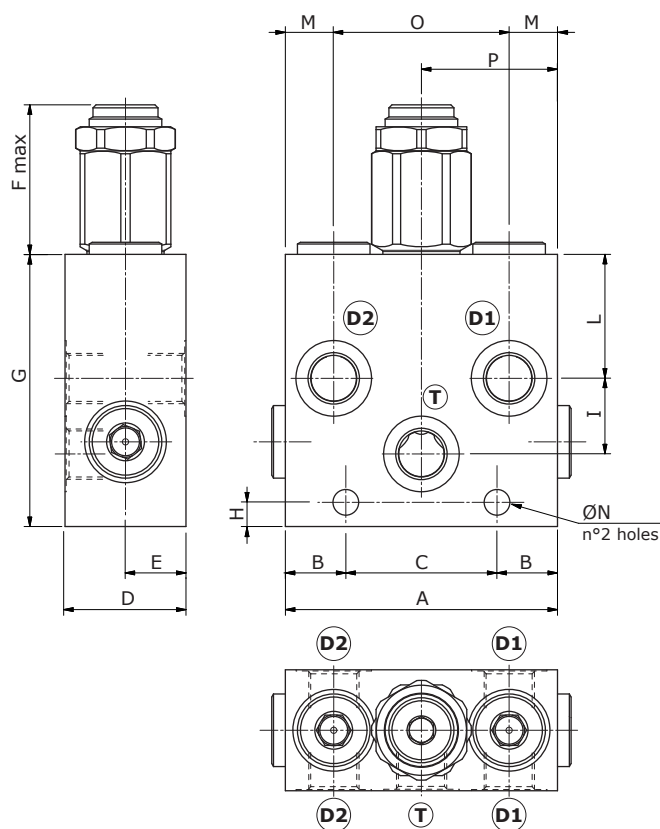

Valve type	All ports
VAA/RU/DL 38	G3/8
VAA/RU/DL 12	G1/2
VAA/RU/DL 34	G3/4
VAA/RU/DL 100	G1"

Dimensions are in mm-in

Valve type	A	B	C	D	E	F	G	H	I	L	M	ØN	O	P
VAA/RU/DL 38	90-3.54	20-0.79	50-1.97	40-1.57	20-0.79	57.7-2.27	90-3.54	8-0.31	25-0.98	41-1.61	16-0.39	8.5-0.33	58-2.28	45-1.77
VAA/RU/DL 12	90-3.54	20-0.79	50-1.97	40-1.57	20-0.79	56.2-2.21	90-3.54	8-0.31	25-0.98	41-1.61	16-0.39	8.5-0.33	58-2.28	45-1.77
VAA/RU/DL 34	110-4.33	24-0.94	62-2.44	55-2.16	27.5-1.08	68.8-2.71	110-4.33	8-0.31	31-1.22	53-2.08	24-0.94	8.5-0.33	62-2.44	56-2.20
VAA/RU/DL 100	140-5.51	32-1.26	76-2.99	60-2.36	30-1.18	68.8-2.72	140-5.51	11-0.43	37-1.46	65-2.56	27-1.06	10.5-0.41	86-3.38	70-2.75

Ordering codes and description composition

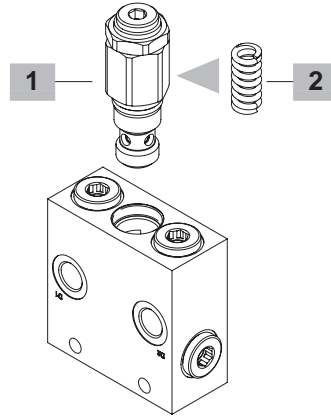
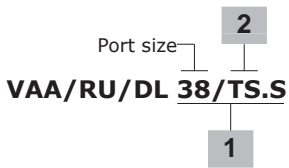

VAA/RU/DL complete valves

Direct acting valve configuration

Standard setting 150 bar @ 5 l/min (2100 psi at 1.32 US gpm)

TYPE	CODE	DESCRIPTION
------	------	-------------

Configuration with G3/8 standard thread

VAA/RU/DL 38/TS.S	1160021102	Aluminium body, setting range 5-210 bar (72.5-3045 psi)
--------------------------	------------	---

VAA/RU/DL 38/TS.S/ac	1160022100	Steel body, as previous one
-----------------------------	------------	-----------------------------

Configuration with G1/2 standard thread

VAA/RU/DL 12/TS.S	1160031102	Aluminium body, setting range 5-210 bar (72.5-3045 psi)
--------------------------	------------	---

VAA/RU/DL 12/TS.S/ac	1160032100	Steel body, as previous one
-----------------------------	------------	-----------------------------

Configuration with G3/4 standard thread

VAA/RU/DL 34/TS.S	1160041102	Aluminium body, setting range 5-210 bar (72.5-3045 psi)
--------------------------	------------	---

VAA/RU/DL 34/TS.S/ac	1160042100	Steel body, as previous one
-----------------------------	------------	-----------------------------

Configuration with G1" standard thread

VAA/RU/DL 100/TS.S	1160051100	Aluminium body, setting range 5-210 bar (72.5-3045 psi)
---------------------------	------------	---

VAA/RU/DL 100/TS.S/ac	1160052101	Steel body, as previous one
------------------------------	------------	-----------------------------

For other steel body configurations, SAE thread and configurations with FPM (Viton) seals, please contact our Sales Dpt.

1 Direct acting pressure relief valves

Standard setting 150 bar @ 5 l/min (2100 psi at 1.32 US gpm)

TYPE	CODE	DESCRIPTION
------	------	-------------

For G3/8 and G1/2 ports configuration

VMPD 12/TS.S	1120030402	Setting range 5-210 bar (72.5-3050 psi)
---------------------	------------	---

For G3/4 ports configuration

VMPD 34/TS.S	1120040402	Setting range 5-210 bar (72.5-3050 psi)
---------------------	------------	---

For G1" ports configuration

VMPD 100/TS.S	1120050402	Setting range 5-210 bar (72.5-3050 psi)
----------------------	------------	---

2 Pressure setting spring

TYPE	CODE	DESCRIPTION
------	------	-------------

For VAA/RU/DL 38, 12 and 100 valves

TS	3ML1164000	Spring for range 5-210 bar (72.5-3050 psi)
-----------	------------	--

TR	3ML1164001	Spring for range 50-350 bar (725-5100 psi)
-----------	------------	--

For VAA/RU/DL 34 valve

TS	3ML1194500	Spring for range 5-210 bar (72.5-3050 psi)
-----------	------------	--

TR	3ML1194501	Spring for range 50-350 bar (725-5100 psi)
-----------	------------	--

Rating diagrams

VAA/RU/DL 38 pressure vs. flow

Std. setting @ 5 l/min (1.32 US gpm)

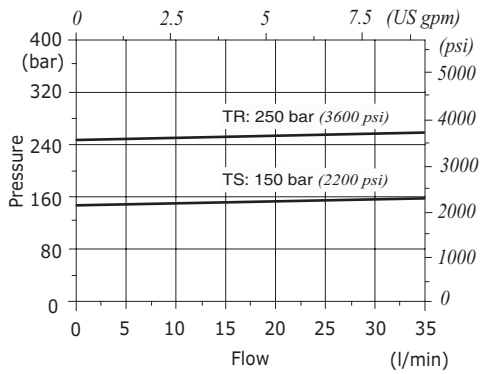

VAA/RU/DL 12 pressure dop vs. flow

Std. setting @ 5 l/min (1.32 US gpm)

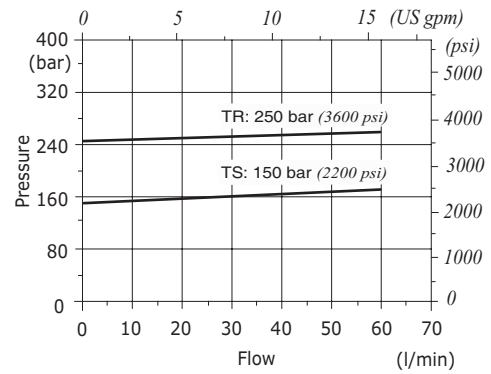

VAA/RU/DL 34-100 pressure vs. flow

Std. setting @ 5 l/min (1.32 US gpm)

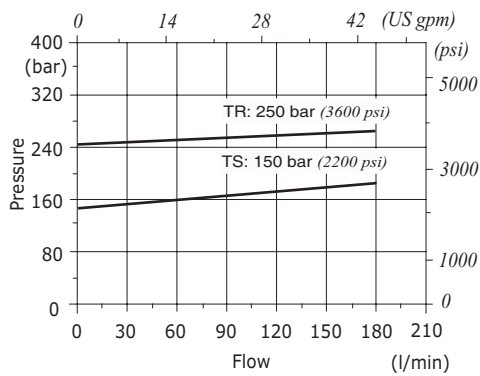



Type VRPRL-VRPRL/U pressure reducing valves

- With relieving

Technical specifications and diagrams are measured with mineral oil of 46 cSt viscosity at 40°C (104°F) temperature.

	VRPRL-VRPRL/U 38	VRPRL-VRPRL/U 12
Nominal flow	20 l/min (5.3 US gpm)	50 l/min (13.2 US gpm)
Max. pressure	Aluminium body = 210 bar (3050 psi) Steel body = 350 bar (5100 psi)	
Oil leakage	20 cm ³ /min at 150 bar (1.22 in ³ /min. at 2200 psi)	
Fluid	mineral based oil	
Viscosity	from 10 to 200 cSt	
Max. level of contamination	18/16/13 ISO4406	
Fluid temperature	with NBR seals from -20°C (-4°F) to 80°C (176°F)	
Environmental temp. for working conditions	from -40°C (-40°F) to 100°C (212°F)	
Weight	<i>aluminium</i>	0.83 kg (1.83 lb)
	<i>steel</i>	1.75 kg (3.86 lb)
		1.20 kg (2.64 lb)
		2.58 kg (5.69 lb)

NOTE - For different conditions, please contact Walvoil Sales Dpt.

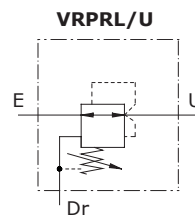
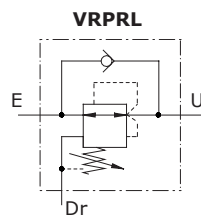

Dimensions

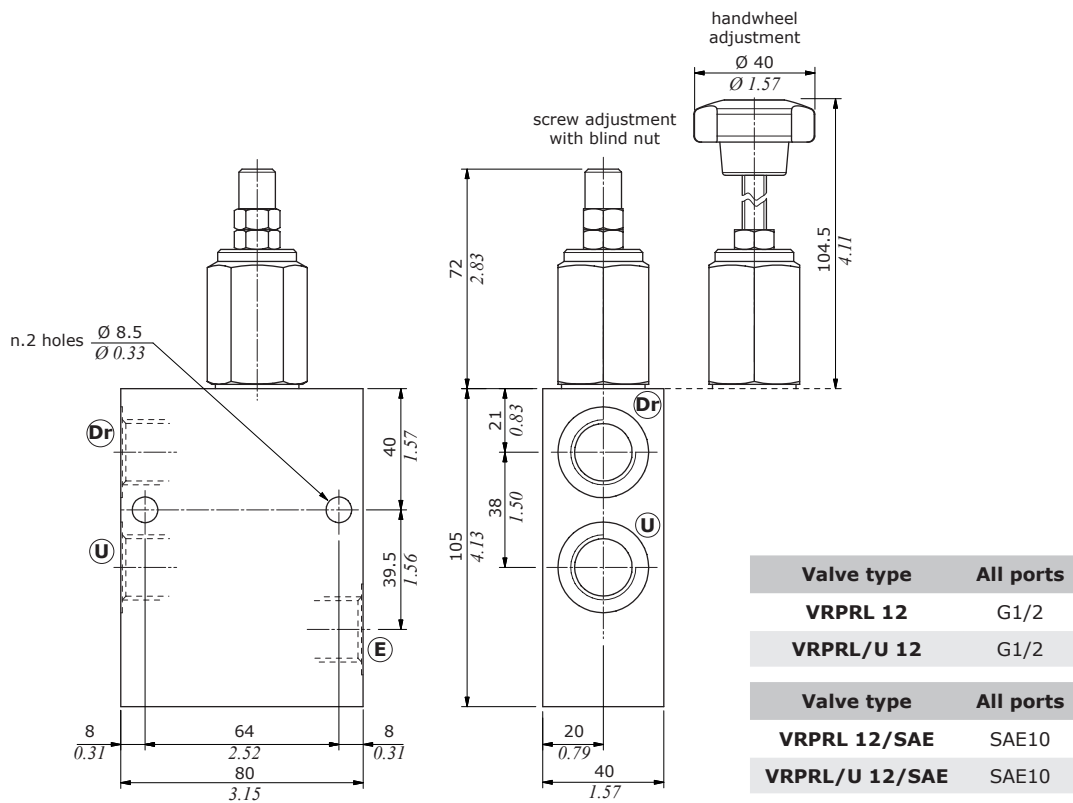
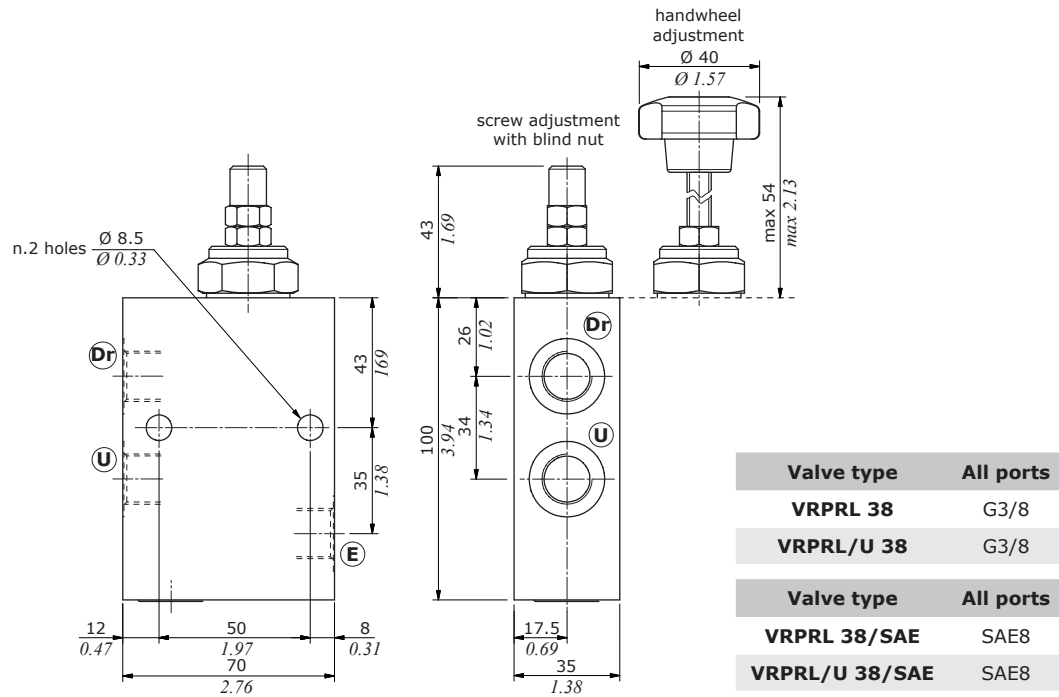

Ordering codes and description composition

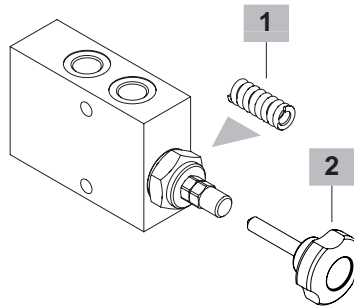
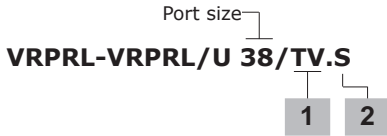

VRPRL-VRPRL/U complete valves

Valve configuration with reverse free flow check
Standard setting 90 bar @ 5 l/min (1300 psi @ 1.32 US gpm)

TYPE	CODE	DESCRIPTION
VRPRL 38/TV.S	1230021102	Aluminium body, setting range 40-110 bar (580-1600 psi)

VRPRL 38/TV.S/ac 1230022100 Steel body, as previous one

Configuration with G1/2 standard thread

VRPRL 12/TV.S	1230031102	Aluminium body, setting range 40-110 bar (580-1600 psi)
----------------------	------------	---

VRPRL 12/TV.S/ac 1230032100 Steel body, as previous one

Configuration with SAE8 standard thread

VRPRL 38/TV.S/SAE	1230021200	Aluminium body, setting range 40-110 bar (580-1600 psi)
--------------------------	------------	---

Configuration with SAE10 standard thread

VRPRL 12/TV.S/SAE	1230031200	Aluminium body, setting range 40-110 bar (580-1600 psi)
--------------------------	------------	---

Valve configuration with check valve

Standard setting 90 bar @ 5 l/min (1300 psi @ 1.32 US gpm)

TYPE	CODE	DESCRIPTION
VRPRL/U 38/TV.S	1233021102	Aluminium body, setting range 40-110 bar (580-1600 psi)

VRPRL/U 38/TV.S/ac 1233022100 Steel body, as previous one

Configuration with G1/2 standard thread

VRPRL/U 12/TV.S	1233031102	Aluminium body, setting range 40-110 bar (580-1600 psi)
------------------------	------------	---

VRPRL/U 12/TV.S/ac 1233032102 Steel body, as previous one

Configuration with SAE8 standard thread

VRPRL/U 38/TV.S/SAE	1233021201	Aluminium body, setting range 40-110 bar (580-1600 psi)
----------------------------	------------	---

Configuration with SAE10 standard thread

VRPRL/U 12/TV.S/SAE	1233031105	Aluminium body, setting range 40-110 bar (580-1600 psi)
----------------------------	------------	---

For other steel body configurations, SAE thread and configurations with FPM (Viton) seals please contact our Sales Dpt.

1 Pressure setting spring

TYPE	CODE	DESCRIPTION
For VRPRL 38 valve		
TB	3ML1133100	Setting range 5-50 bar (72.5-725 psi)
TV	3MOL314330	Setting range 40-110 bar (580-1600 psi)
TS	3MOL315330	Setting range 100-200 bar (1450-2900 psi)
For VRPRL 12 valve		
TB	3ML1166804	Setting range 5-50 bar (72.5-725 psi)
TV	3ML1146800	Setting range 40-110 bar (580-1600 psi)
TS	3ML1166805	Setting range 100-200 bar (1450-2900 psi)

2 Accessories

TYPE	CODE	DESCRIPTION
V	4VL2407100	Handwheel

Rating diagrams

VRPRL-VRPRL/U 38

Relieving diagram from U to Dr Pressure vs. Flow from E to U

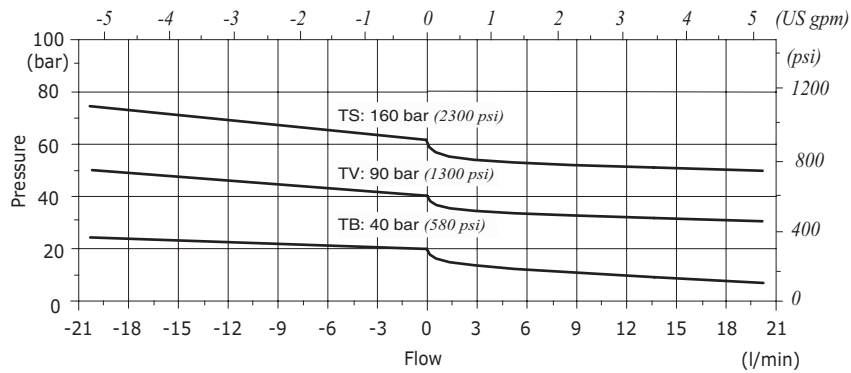

VRPRL-VRPRL/U 12

Relieving diagram from U to Dr Pressure vs. Flow from E to U

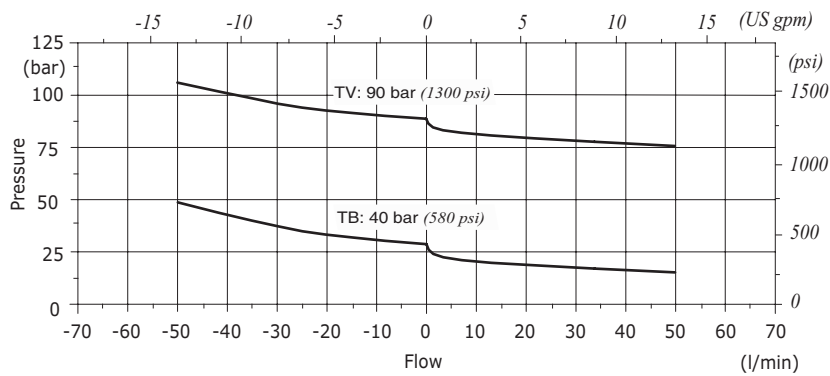



Type VDSRL sequence valves

- Direct acting

Technical specifications and diagrams are measured with mineral oil of 46 cSt viscosity at 40°C (104°F) temperature.

	VDSRL 3-14	VDSRL 5-38 VDSRL 5Y-38	VDSRL 5-12 VDSRL 5Y-12	VDSRL 10-12	VDSRL 10-34	VDSRL 20-34	
Nominal flow	10 l/min (2.6 US gpm)	25 l/min (6.6 US gpm)	35 l/min (9.2 US gpm)	50 l/min (13.2 US gpm)	70 l/min (18.5 US gpm)	120 l/min (31.7 US gpm)	
Max. pressure	Aluminium body = 210 bar (3050 psi) Steel body = 350 bar (5100 psi)						
Fluid	mineral based oil						
Viscosity	from 10 to 200 cSt						
Max. level of contamination	18/16/13 ISO4406						
Fluid temperature	with NBR seals from -20°C (-4°F) to 80°C (176°F)						
Environmental temp. for working conditions	from -40°C (-40°F) to 100°C (212°F)						
Weight	alum.	0.48 kg (1.06 lb)	0.63 kg (1.39 lb)	0.67 kg (1.48 lb)	1 kg (2.20 lb)	1.10 kg (2.42 lb)	1.80 kg (3.97 lb)
	steel	1.08 kg (2.38 lb)	1.49 kg (3.28 lb)	1.54 kg (3.40 lb)	2.15 kg (4.74 lb)	2.13 kg (4.70 lb)	4 kg (8.82 lb)

NOTE - For different conditions, please contact Walvoil Sales Dpt.

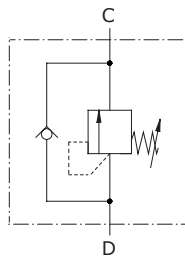

Dimensions

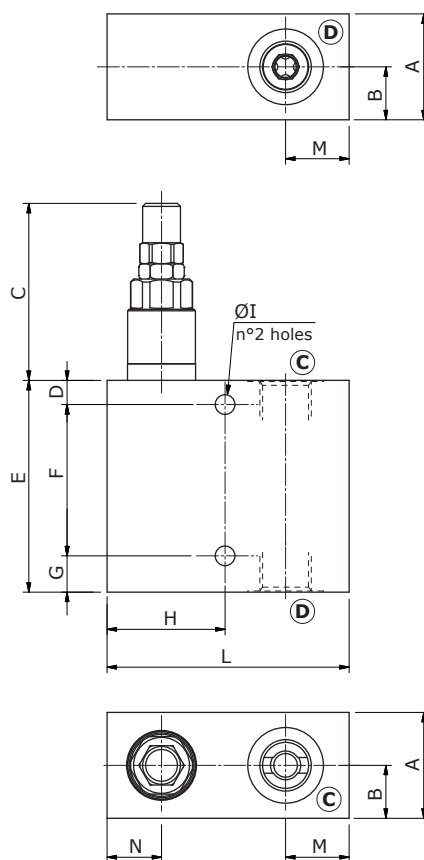

Valve type	All ports
VDSRL 3-14	G1/4
VDSRL 5-38 VDSRL 5Y-38	G3/8
VDSRL 5-12 VDSRL 5Y-12	G1/2
VDSRL 10-12	G1/2
VDSRL 10-34	G3/4
VDSRL 20-34	G3/4

Dimensions are in mm-in

Valve type	A	B	C	D	E	F	G	ØI	H	L	M	N
VDSRL 3-14	30-1.18	15-0.59	53-2.09	7-0.27	70-2.75	50-1.97	13-0.51	6.5-0.25	34-1.34	65-2.56	15-0.59	15-0.59
VDSRL 5-38 VDSRL 5Y-38	35-1.38	17.5-0.69	60-1.36	8-0.31	70-2.75	50-1.97	12-0.47	6.5-0.25	39-1.53	80-3.15	21-0.83	18-0.71
VDSRL 5-12 VDSRL 5Y-12	35-1.38	17.5-0.69	60-1.36	8-0.31	75-2.95	55-2.16	12-0.47	8.5-0.33	39-1.53	80-3.15	21-0.83	18-0.71
VDSRL 10-12	40-1.57	20-0.79	67-2.64	8-0.31	80-3.15	60-2.36	12-0.47	8.5-0.33	44-1.73	90-3.54	24-0.94	20-0.79
VDSRL 10-34	40-1.57	20-0.79	67-2.64	8-0.31	90-3.54	70-2.75	12-0.47	8.5-0.33	44-1.73	95-3.74	27-1.06	20-0.79
VDSRL 20-34	50-1.97	25-0.98	76.5-3.01	8-0.31	100-3.94	80-3.15	12-0.47	8.5-0.33	53-2.09	110-4.33	32-1.26	25-0.98

Ordering codes and description composition

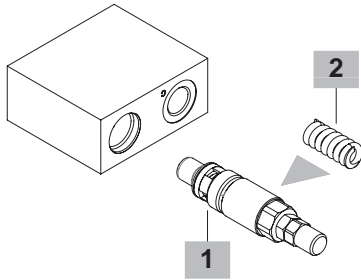
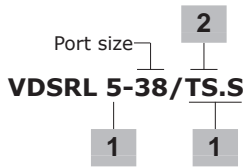

VDSRL complete valves

With direct acting valve type: standard setting is referred to 5 l/min (1.32 US gpm)

TYPE	CODE	DESCRIPTION
Configuration with G1/4 ports		
VDSRL 03-14/TS.S	1200011102	Aluminium body, setting range 50-200 bar (725-2900 psi) Standard setting 160 bar (2300 psi)
VDSRL 03-14/TS.S/ac	1200012100	Steel body, as previous one
Configuration with G3/8 ports		
VDSRL 5-38/TS.S	1200021102	Aluminium body, setting range 50-220 bar (725-3200 psi) Standard setting 160 bar (2300 psi)
VDSRL 5-38/TS.S/ac	1200022102	Steel body, as previous one
VDSRL 5Y-38/TS.S	1200021112	Aluminium body, setting range 140-190 bar (2030-2750 psi) Standard setting 150 bar (2200 psi)
Configuration with G1/2 ports		
VDSRL 5-12/TS.S	1200021152	Aluminium body, setting range 50-220 bar (725-3200 psi) Standard setting 160 bar (2300 psi)
VDSRL 5-12/TS.S/ac	1200022150	Steel body, as previous one
VDSRL 10-12/TS.S	1200031102	Aluminium body, setting range 50-220 bar (725-3200 psi) Standard setting 160 bar (2300 psi)
VDSRL 10-12/TS.S/ac	1200032100	Steel body, as previous one
Configuration with G3/4 ports		
VDSRL 10-34/TS.S	1200031152	Aluminium body, setting range 50-220 bar (725-3200 psi) Standard setting 160 bar (2300 psi)
VDSRL 10-34/TS.S/ac	1200032100	Steel body, as previous one
VDSRL 20-34/TS.S	1200041102	Aluminium body, setting range 50-220 bar (725-3200 psi) Standard setting 160 bar (2300 psi)
VDSRL 20-34/TS.S/ac	1200042100	Steel body, as previous one

For other steel body configurations, SAE thread and configurations with FPM (Viton) seals please contact our Sales Dpt.

1 Direct acting pressure relief valves

Standard setting 160 bar at 5 l/min (2300 psi at 1.32 US gpm)

TYPE	CODE	DESCRIPTION
For G1/4 ports configuration		
MC08A/0S2B	0MC08002000	Setting range 50-200 bar (725-2900 psi) Standard setting 160 bar (2300 psi)
For G3/8 ports configuration		
VMP 5/TS.S	1100520408	Setting range 50-220 bar (725-3200 psi) Standard setting 160 bar (2300 psi)
VMP 5Y/TS.S	1100520406	Setting range 140-190 bar (2030-2750 psi) Standard setting 150 bar (2200 psi)
For G1/2 ports configuration		
VMP 5/TS.S	1100520408	Setting range 50-220 bar (725-3200 psi) Standard setting 160 bar (2300 psi)
VMP 5Y/TS.S	1100520406	Setting range 140-190 bar (2030-2750 psi) Standard setting 150 bar (2200 psi)
VMP 10/TS.S	1100530400	Setting range 50-220 bar (725-3200 psi) Standard setting 160 bar (2300 psi)
For G3/4 ports configuration		
VMP 10/TS.S	1100530400	Setting range 50-220 bar (725-3200 psi) Standard setting 160 bar (2300 psi)
VMP 20/TS.S	1100540400	Setting range 50-220 bar (725-3200 psi) Standard setting 160 bar (2300 psi)

2 Pressure setting springs

TYPE	CODE	DESCRIPTION
For MC08A valve		
TB	3ML1092500	Setting range 5-50 bar (72.5-725 psi)
TS	3ML1092501	Setting range 50-200 bar (725-2900 psi)
TR	3ML1092502	Setting range 150-350 bar (2175-5075 psi)
For VMP 5 valve		
TB	3MOL314311	Setting range 5-40 bar (72.5-580 psi)
TV	3MOL314330	Setting range 20-80 bar (290-1150 psi)
TS	3MOL315330	Setting range 50-220 bar (725-3200 psi)
TR	3ML1143600	Setting range 180-350 bar (2600-5100 psi)
For VMP 5Y valve		
TB	3MOL314311	Setting range 5-80 bar (72.5-1150 psi)
TV	3MOL314330	Setting range 40-150 bar (580-2200 psi)
TS	3ML1143400	Setting range 140-190 bar (2050-2750 psi)
TR	3MOL315330	Setting range 180-350 bar (2600-5075 psi)
For VMP 10 valve		
TB	3MOL316410	Setting range 5-40 bar (72.5-580 psi)
TV	3ML1154300	Setting range 20-80 bar (290-1150 psi)
TS	3MOL317420	Setting range 50-220 bar (725-3200 psi)
TR	3MOL317440	Setting range 180-350 bar (2600-5100 psi)
For VMP 20 valve		
TB	3ML1184300	Setting range 5-40 bar (72.5-580 psi)
TV	3ML1174500	Setting range 20-80 bar (290-1150 psi)
TS	3ML1204200	Setting range 50-220 bar (725-3200 psi)
TR	3ML1214500	Setting range 180-350 bar (2600-5100 psi)

Rating diagrams

VDSRL 03-14 pressure vs. flow
Std. setting at 5 l/min (1.32 US gpm)

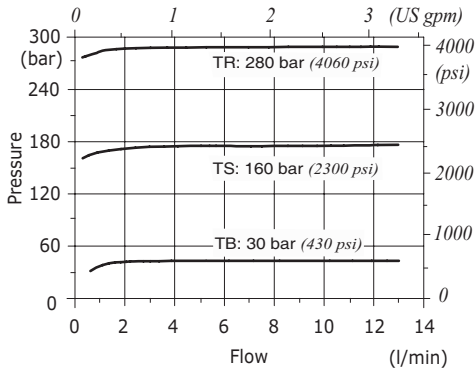

VDSRL 5 (38-12) pressure vs. flow
Std. setting at 5 l/min (1.32 US gpm)

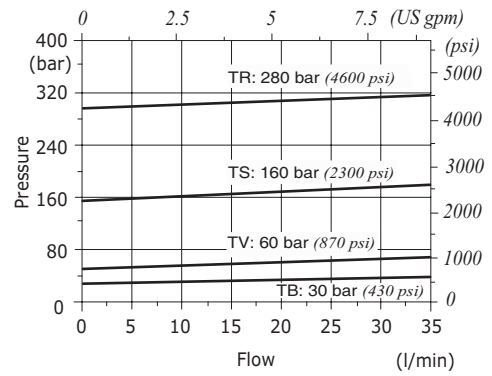

VDSRL 5Y (38-12) pressure vs. flow
Std. setting at 5 l/min (1.32 US gpm)

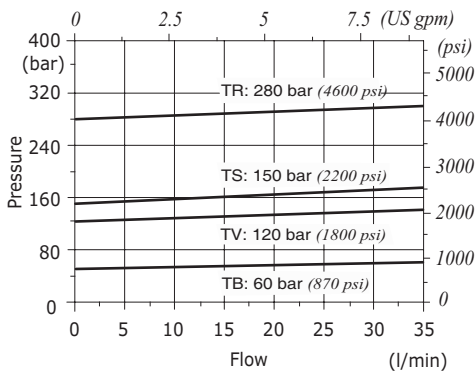

VDSRL 10 (12-34) pressure vs. flow
Std. setting at 5 l/min (1.32 US gpm)

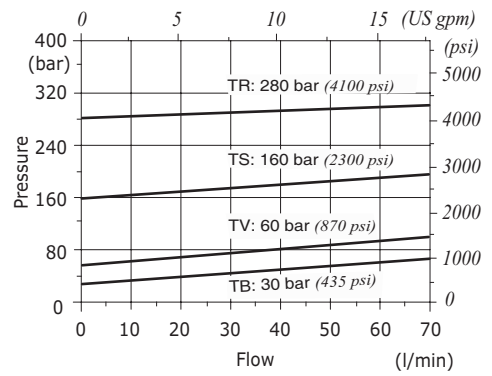

VDSRL 20-34 pressure drop vs. flow
Std. setting at 5 l/min (1.32 US gpm)

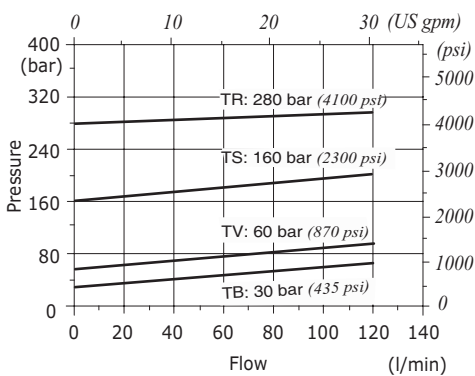



Type VDSRL/APP sequence valves

- Direct acting
- Back-pressure proof type

Technical specifications and diagrams are measured with mineral oil of 46 cSt viscosity at 40°C (104°F) temperature.

	VDSRL/APP 5-38	VDSRL/APP 5-12	VDSRL/APP 10-12	VDSRL/APP 10-34	VDSRL/APP 20-34	
Nominal flow	25 l/min (6.6 US gpm)	35 l/min (9.2 US gpm)	50 l/min (13.2 US gpm)	70 l/min (18.5 US gpm)	120 l/min (31.7 US gpm)	
Max. pressure	Aluminium body = 210 bar (3050 psi) Steel body = 350 bar (5100 psi)					
Fluid	mineral based oil					
Viscosity	from 10 to 200 cSt					
Max. level of contamination	18/16/13 ISO4406					
Fluid temperature	with NBR seals from -20°C (-4°F) to 80°C (176°F)					
Environmental temp. for working conditions	from -40°C (-40°F) to 100°C (212°F)					
Weight	<i>alum.</i>	0.75 kg (1.65 lb)	0.78 kg (1.72 lb)	1.02 kg (2.25 lb)	1.12 kg (2.47 lb)	2.03 kg (4.48 lb)
	<i>steel</i>	1.60 kg (3.53 lb)	1.65 kg (3.64 lb)	2.17 kg (4.78 lb)	2.46 kg (5.42 lb)	4.24 kg (9.35 lb)

NOTE - For different conditions, please contact Walvoil Sales Dpt.

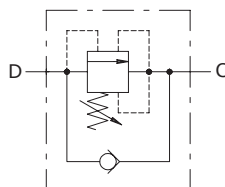

Dimensions

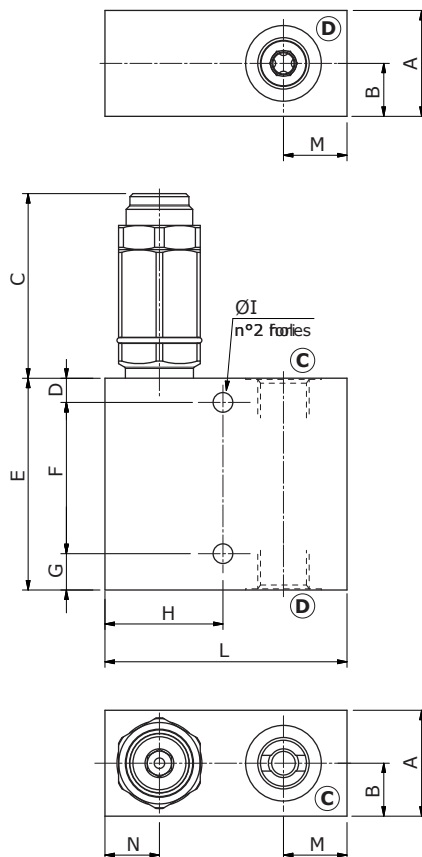

Valve type	All ports
VDSRL/APP 5-38	G3/8
VDSRL/APP 5-12	G1/2
VDSRL/APP 10-12	G1/2
VDSRL/APP 10-34	G3/4
VDSRL/APP 20-34	G3/4
Valve type	All ports
VDSRL/APP 5-38/SAE	SAE8

Dimensions are in mm-*in*

Valve type	A	B	C	D	E	F	G	H	L	M	ØI	N
VDSRL/APP 5-38 VDSRL/APP 5-38/SAE	35-1.38	17.5-0.69	62-2.44	8-0.31	70-2.75	50-1.97	12-0.47	39-1.53	80-3.15	21-0.83	6.5-0.25	18-0.71
VDSRL/APP 5-12	35-1.38	17.5-0.69	62-2.44	8-0.31	75-2.95	55-2.16	12-0.47	39-1.53	80-3.15	21-0.83	8.5-0.33	18-0.71
VDSRL/APP 10-12	40-1.57	20-0.79	62-2.44	8-0.31	80-3.15	60-2.36	12-0.47	44-1.73	90-3.54	24-0.94	8.5-0.33	20-0.79
VDSRL/APP 10-34	40-1.57	20-0.79	62-2.44	8-0.31	90-3.54	70-2.75	12-0.47	44-1.73	95-3.74	27-1.10	8.5-0.33	20-0.79
VDSRL/APP 20-34	50-1.97	25-0.98	82-3.23	8-0.31	100-3.94	80-3.15	12-0.47	53-2.09	110-4.33	32-1.26	8.5-0.33	25-0.98

Ordering codes and description composition

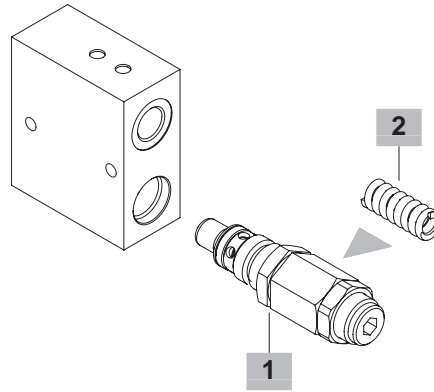
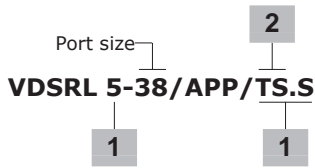

VDSRL/APP complete valves

With direct acting valve: standard setting 160 bar at 5 l/min (2320 psi at 1.32 US gpm)

TYPE	CODE	DESCRIPTION
Configuration with G3/8 ports		
VDSRL 5-38/APP/TS.S	1201021101	Aluminium body, setting range 50-220 bar (725-3200 psi).
VDSRL 5-38/APP/TS.S/ac	1201022100	Steel body, as previous one
Configuration with G1/2 ports		
VDSRL 5-12/APP/TS.S	1201021151	Aluminium body, setting range 50-220 bar (725-3200 psi)
VDSRL 10-12/APP/TS.S	1201031100	Aluminium body, setting range 50-220 bar (725-3200 psi)
VDSRL 10-12/APP/TS.S/ac	1201032100	Steel body, as previous one
Configuration with G3/4 ports		
VDSRL 10-34/APP/TS.S	1201031150	Aluminium body, setting range 50-220 bar (725-3200 psi)
VDSRL 10-34/APP/TS.S/ac	1201031150	Steel body, as previous one
VDSRL 20-34/APP/TS.S	1201041100	Aluminium body, setting range 50-220 bar (725-3200 psi)
VDSRL 20-34/APP/TS.S/ac	1201042100	Steel body, as previous one
Configuration with SAE8 ports		
VDSRL 5-38/APP/TS.S/SAE	1201021200	Aluminium body, setting range 50-220 bar (725-3200 psi).
VDSRL 5-38/APP/TS.S/ac/SAE	1201022203	Steel body, as previous one

For other steel body configurations, SAE thread and configurations with FPM (Viton) seals please contact our Sales Dpt.

1 Direct acting pressure relief valve

Standard setting 160 bar at 5 l/min (2320 psi at 1.32 US gpm)

TYPE	CODE	DESCRIPTION
For G/8, G1/2 and SAE8 ports configuration		
VMP 5/APP/TS.S	1101020400	Direct acting type, setting range 50-220 bar (725-3200 psi)
For G1/2 and G3/4 ports configuration		
VMP 10/APP/TS.S	1101030400	Direct acting type, setting range 50-220 bar (725-3200 psi)
For G3/4 ports configuration		
VMP 20/APP/TS.S	1101040400	Direct acting type, setting range 50-220 bar (725-3200 psi)

2 Pressure setting springs

TYPE	CODE	DESCRIPTION
For VMP 5/APP and VMP 10/APP valves		
TB	3MOL314330	Setting range 5-50 bar (72.5-725 psi)
TV	3ML1144000	Setting range 20-100 bar (290-1450 psi)
TS	3ML1144001	Setting range 50-220 bar (725-3200 psi)
TR	3ML1144002	Setting range 100-350 bar (1450-5100 psi)
For VMP 20/APP valve		
TB	3ML1174500	Setting range 5-50 bar (72.5-725 psi)
TV	3ML1194500	Setting range 20-100 bar (290-1450 psi)
TS	3ML1194501	Setting range 50-220 bar (725-3200 psi)
TR	3ML1194502	Setting range 100-350 bar (1450-5100 psi)

Rating diagrams

VDSRL 5 (38-12)/APP pressure vs. flow
Std. setting at 5 l/min (1.32 US gpm)

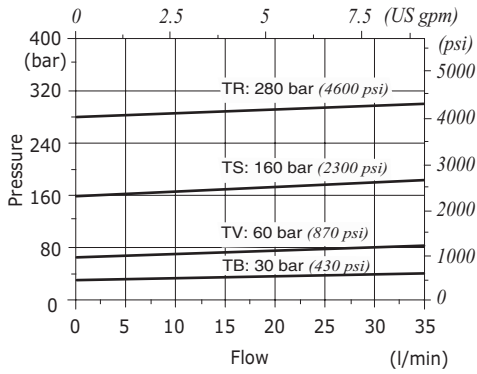

VDSRL 10 (12-34)/APP pressure vs. flow
Std. setting at 5 l/min (1.32 US gpm)

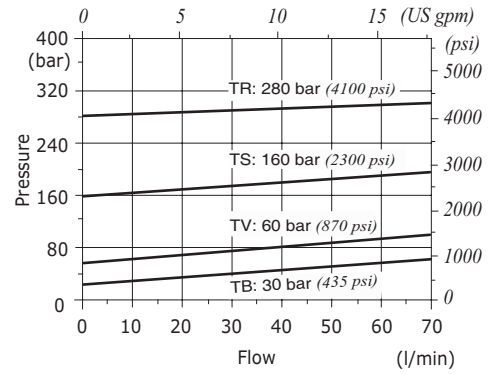

VDSRL 20-34/APP pressure vs. flow
Std. setting at 5 l/min (1.32 US gpm)

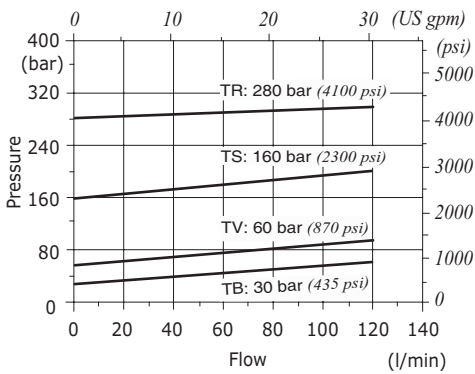



Type VDSB/B sequence valves

- Differential acting

Technical specifications and diagrams are measured with mineral oil of 46 cSt viscosity at 40°C (104°F) temperature.

	VDSB/B 38	VDSB/B 12	VDSB/B 34	VDSB/B 100	
Nominal flow	30 l/min (7.9 US gpm)	60 l/min (16 US gpm)	120 l/min (31.7 US gpm)	200 l/min (52.8 US gpm)	
Max. pressure	Aluminium body = 210 bar (3050 psi) Steel body = 350 bar (5100 psi)				
Fluid	mineral based oil				
Viscosity	10-200 cSt				
Max. level of contamination	18/16/13 ISO4406				
Fluid temperature	with NBR seals from -20°C (-4°F) to 80°C (176°F)				
Environmental temp. for working conditions	from -40°C (-40°F) to 100°C (212°F)				
Weight	alum.	0.60 kg (1.32 lb)	0.80 kg (1.76 lb)	1.13 kg (2.49 lb)	2.10 kg (4.63 lb)
	steel	1.06 kg (2.34 lb)	1.53 kg (3.37 lb)	2.33 kg (5.14 lb)	4.82 kg (10.63 lb)

NOTE - For different conditions, please contact Walvoil Sales Dpt.

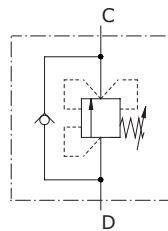

Dimensions

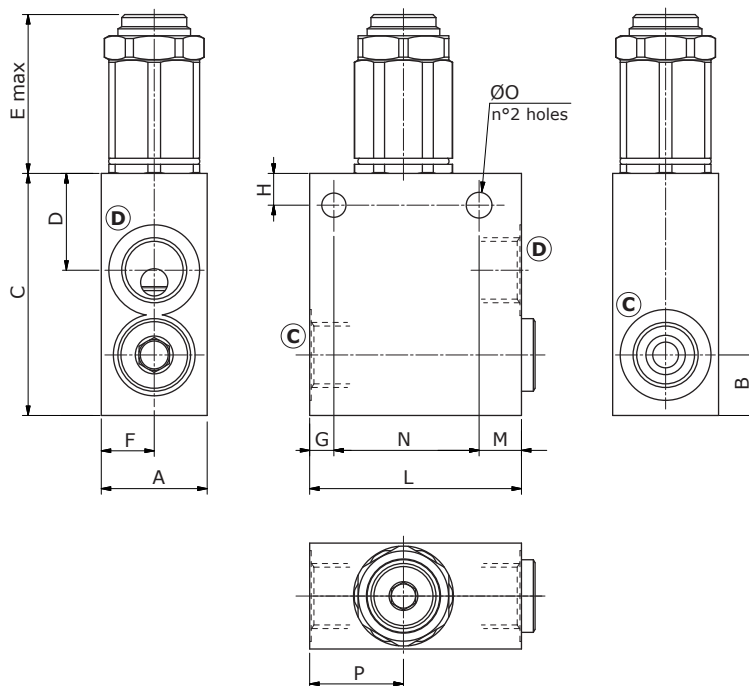

Valve type	All ports
VDSD/B 38	G3/8
VDSD/B 12	G1/2
VDSD/B 34	G3/4
VDSD/B 100	G1"

Valve type	All ports
VDSD/B 38/SAE	SAE8
VDSD/B 12/SAE	SAE10
VDSD/B 34/SAE	SAE12
VDSD/B 100/SAE	SAE16

Dimensions are in mm-in

Valve type	A	B	C	D	E max	F	G	ØO	H	L	M	N	P
VDSD/B 38 VDSD/B 38/SAE	30-1.18	16-0.63	74-2.91	32,5-1.28	59-2.32	15-0.59	8-0.31	8.5-0.33	11.5-0.45	60-2.36	12-0.47	40-1.57	28-1.10
VDSD/B 12 VDSD/B 12/SAE	35-1.38	20-0.79	80-3.15	32-1.26	58-2.28	17.5-0.69	8-0.31	8.5-0.33	10.5-0.41	70-2.75	14-0.55	48-1.89	31-1.22
VDSD/B 34 VDSD/B 34/SAE	40-1.57	22-0.87	90-3.54	34-1.34	58-2.28	20-0.79	10-0.39	10.5-0.41	11-0.43	90-3.54	10-0.39	70-2.75	36-1.42
VDSD/B 100 VDSD/B 100/SAE	60-2.36	38-1.50	126-4.96	42-1.65	51,5-2.03	30-1.18	12-0.47	12-0.47	12-0.47	90-3.54	18-0.71	60-2.36	36-1.42

Ordering codes and description composition

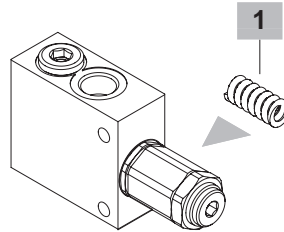
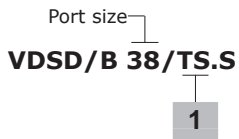

VDSD/B complete valves

With differential valve type: standard setting 160 bar at 5 l/min (2320 psi at 1.32 US gpm)

TYPE	CODE	DESCRIPTION
Configuration with G3/8 standard thread		
VDSD/B 38/TS.S	1204021102	Aluminium body, setting range 50-220 bar (725-3200 psi)
VDSD/B 38/TS.S/ac	1204022101	Steel body, as previous one
Configuration with G1/2 standard thread		
VDSD/B 12/TS.S	1204031102	Aluminium body, setting range 50-220 bar (725-3200 psi)
VDSD/B 12/TS.S/ac	1204032100	Steel body, as previous one
Configuration with G3/4 standard thread		
VDSD/B 34/TS.S	1204041102	Aluminium body, setting range 50-220 bar (725-3200 psi)
VDSD/B 34/TS.S/ac	1204042100	Steel body, as previous one
Configuration with G1" standard thread		
VDSD/B 100/TS.S	1204051102	Aluminium body, setting range 50-220 bar (725-3200 psi)
VDSD/B 100/TS.S/ac	1204052100	Steel body, as previous one
Configuration with SAE8 standard thread		
VDSD/B 38/TS.S/SAE	1204021200	Aluminium body, setting range 50-220 bar (725-3200 psi)
Configuration with SAE10 standard thread		
VDSD/B 12/TS.S/SAE	1204031201	Aluminium body, setting range 50-220 bar (725-3200 psi)
Configuration with SAE12 standard thread		
VDSD/B 34/TS.S/SAE	1204041200	Aluminium body, setting range 50-220 bar (725-3200 psi)
Configuration with SAE16 standard thread		
VDSD/B 100/TS.S/SAE	1204051200	Aluminium body, setting range 50-220 bar (725-3200 psi)

For other steel body configurations, SAE thread and configurations with FPM (Viton) seals please contact our Sales Dpt.

1 Pressure setting springs

TYPE	CODE	DESCRIPTION
For VDSD/B 38 valve		
TV	3ML1144000	Setting range 20-100 bar (290-1450 psi)
TS	3ML1144001	Setting range 50-220 bar (725-3200 psi)
TR	3ML1144002	Setting range 100-350 bar (1450-5100 psi)
For VDSD/B 12, 34 and 100 valves		
TV	3ML1164000	Setting range 20-100 bar (290-1450 psi)
TS	3ML1164001	Setting range 50-220 bar (725-3200 psi)
TR	3ML1164002	Setting range 100-350 bar (1450-5100 psi)

Rating diagrams

VSD/B 38 pressure vs. flow

Std. setting at 5 l/min (1.32 US gpm)

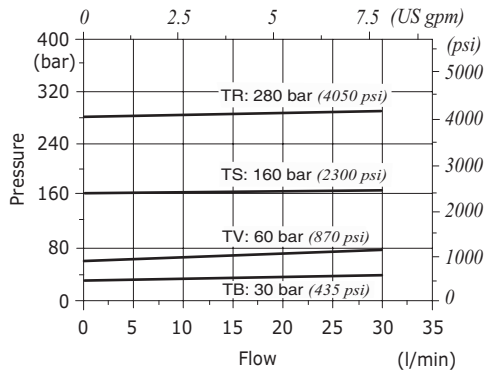

VSD/B 12 pressure vs. flow

Std. setting at 5 l/min (1.32 US gpm)

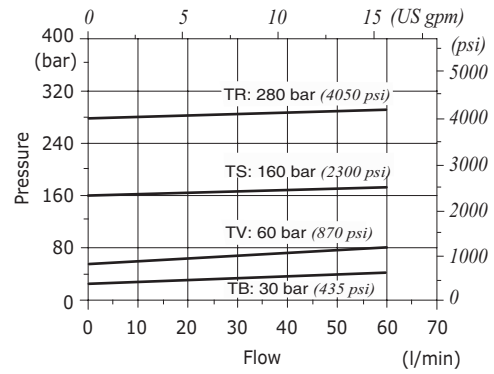

VSD/B 34 pressure vs. flow

Std. setting at 5 l/min (1.32 US gpm)

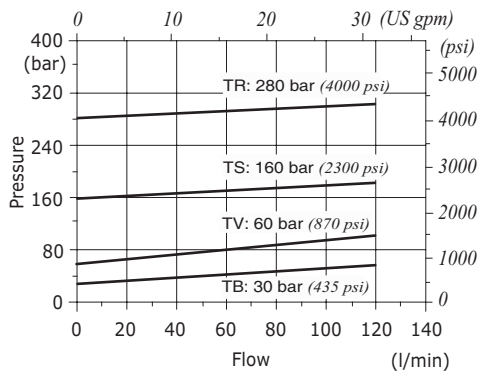

VSD/B 100 pressure vs. flow

Std. setting at 5 l/min (1.32 US gpm)

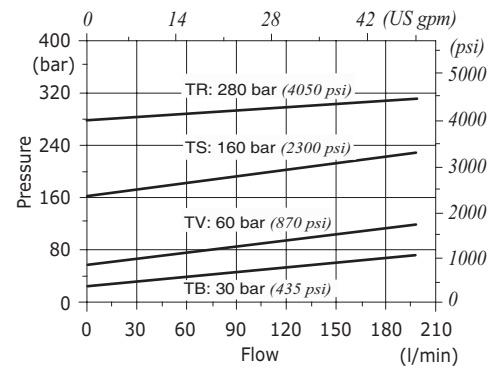



Type VUI check valves

- Poppet type

Technical specifications and diagrams are measured with mineral oil of 46 cSt viscosity at 40°C (104°F) temperature.

	VUI 38	VUI 38/HF	VUI 12	VUI 34	VUI 100
Nominal flow	25 l/min (6.6 US gpm)	40 l/min (10.6 US gpm)	40 l/min (10.6 US gpm)	100 l/min (26.4 US gpm)	160 l/min (42.3 US gpm)
Max. pressure	400 bar (5800 psi)	300 bar (4350 psi)		400 bar (5800 psi)	
Oil leakage	0.25 cm ³ /min (0.015 in ³ /min) at 210 bar (3050 psi)				
Fluid	mineral based oil				
Viscosity	from 10 to 200 cSt				
Max. level of contamination	18/16/13 ISO4406				
Fluid temperature	with NBR seals: from -20°C (-4°F) to 80°C (176°F)				
Environmental temperature for working conditions	from -40°C (-40°F) to 100°C (212°F)				
Weight	Steel 0.08 kg (0.18 lb)	0.075 kg (0.16 lb)	0.15 kg (0.33 lb)	0.30 kg (0.66 lb)	0.54 kg (1.19 lb)

NOTE - For different conditions, please contact Walvoil Sales Dpt.



Dimensions

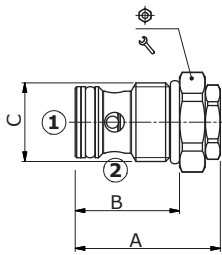

Dimensions are in mm-in

Valve type	A	B	C	\varnothing	Nm-lbft
VUI 38	42-1.65	27-1.06	M20x1.5	24	40-29
VUI 38/HF	34.5 - 1.36	28 - 1.10	M22x1.5	27	50-37
VUI 12	48-1.89	34.5-1.36	M26x1.5	30	60-44
VUI 34	68-2.68	51-2.01	M33x2	38	70-51
VUI 100	75-2.95	54.5-2.14	M42x2	46	80-59

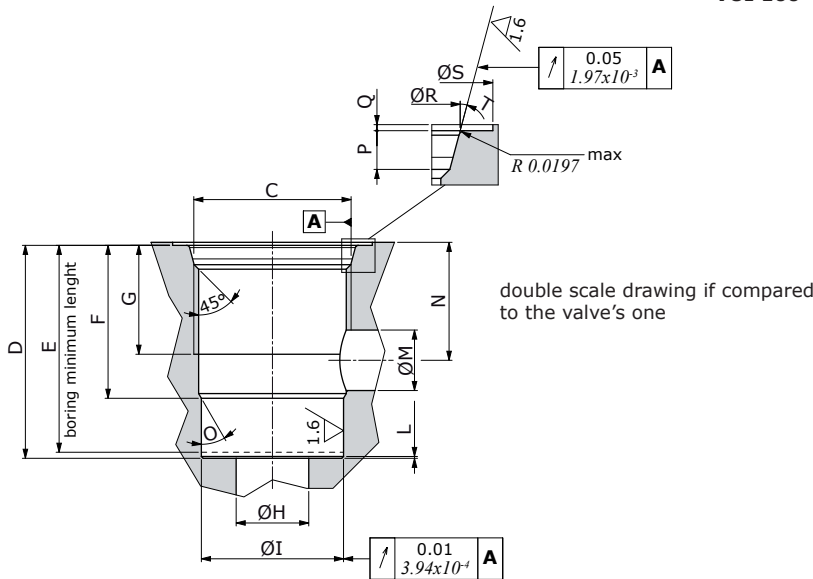

Dimensions are in mm-in

Valve cavity for	C	D	E	F	G	\varnothing H	\varnothing I	L	\varnothing M	N	O	P	Q	\varnothing R	\varnothing S
VUI 38	M20x1.5	29.5 1.16	28 1.10	20.5 0.81	16 0.63	10 0.39	16 H9 0.630 H9	/	7 0.275	16 0.63	30°	3 0.118	0.5 0.020	21 0.83	30 1.18
VUI 12	M26x1.5	35.2 1.39	34.2 1.35	25.3 0.996	18 0.71	12 0.47	23.5 H9 0.925 H9	0.3x45° 0.012x45°	10 0.39	19.5 0.77	30°	3.2 0.126	0.5 0.020	27.6 1.09	33 1.30
VUI 34	M33x2	52.5 2.07	51.5 2.03	39 1.54	28 1.10	20 0.79	27 H9 1.063 H9	0.5x45° 0.020x45	15 0.59	29.5 1.16	20°	3.2 0.126	0.5 0.020	34 1.35	40 1.57
VUI 100	75-2.95	57 2.24	55 2.17	41 1.61	29 1.14	28 1.10	38 H9 1.496 H9	1.5x45° 0.059x45	18 0.71	30 1.18	30°	4.5 0.177	0.5 0.020	43.5 1.71	50 1.97

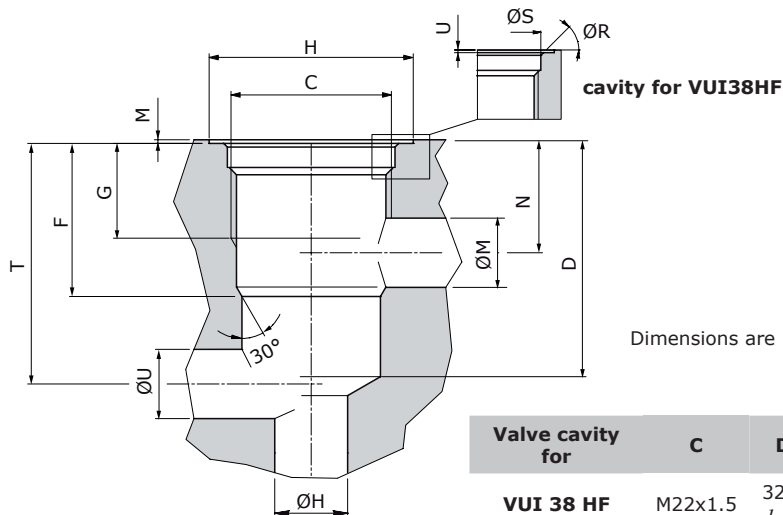

Valve cavity for	C	D	F	G	\varnothing H	\varnothing M	N	T	\varnothing U
VUI 38 HF	M22x1.5	32.5 1.28	21 0.83	15 0.59	max. 18 max. 0.71	max.9 max. 0.35	15.5 0.61	33 1.30	9.5 0.37

Ordering codes and description composition

VUI 38/Pa0,5

1

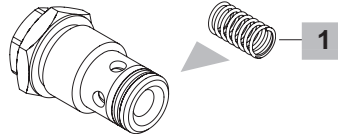

VUI complete valves

TYPE	CODE	DESCRIPTION
VUI 38/Pa0,5	1300020400	Steel body, opening pressure 0.5 bar (7.25 psi)
VUI 38/HF/Pa0,5	1300020900	Steel body, opening pressure 0.5 bar (7.25 psi)
VUI 12/Pa0,5	1300030400	Steel body, opening pressure 0.5 bar (7.25 psi)
VUI 34/Pa0,5	1300040400	Steel body, opening pressure 0.5 bar (7.25 psi)
VUI 100/Pa0,5	1300050400	Steel body, opening pressure 0.5 bar (7.25 psi)

For configurations with FPM (Viton) seals please contact our Sales Dpt.

1 Pressure setting springs

TYPE	CODE	DESCRIPTION
For VUI 38 valve		
Pa0,5	3ML1072001	Opening pressure 0.5 bar (7.25 psi)
Pa5	3ML1072003	Opening pressure 5 bar (72.5 psi)
For VUI 38 HF valve		
Pa0,5	1300020900	Opening pressure 0.5 bar (7.25 psi)
For VUI 12 valve		
Pa0,5	3ML1112900	Opening pressure 0.5 bar (7.25 psi)
Pa5	3ML1072003	Opening pressure 5 bar (72.5 psi)
For VUI 34 valve		
Pa0,5	3ML1155200	Opening pressure 0.5 bar (7.25 psi)
Pa5	3ML1155000	Opening pressure 5 bar (72.5 psi)
For VUI 100 valve		
Pa0,5	3ML1172801	Opening pressure 0.5 bar (7.25 psi)
Pa5	3ML1172800	Opening pressure 5 bar (72.5 psi)

Rating diagrams

VUI 38 pressure drop vs. flow

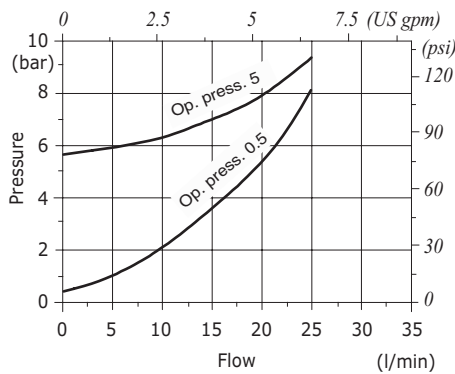

VUI 38 HF pressure drop vs. flow

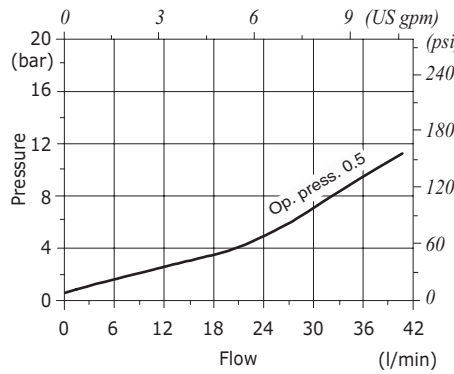

VUI 12 pressure drop vs. flow

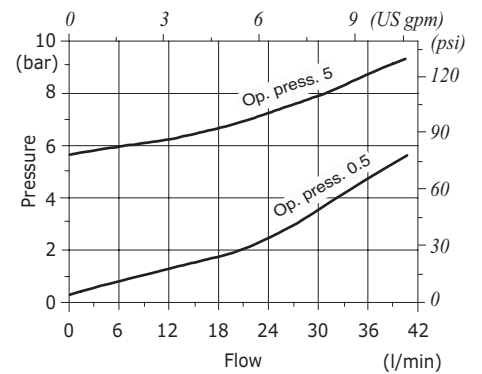

VUI 34 pressure drop vs. flow

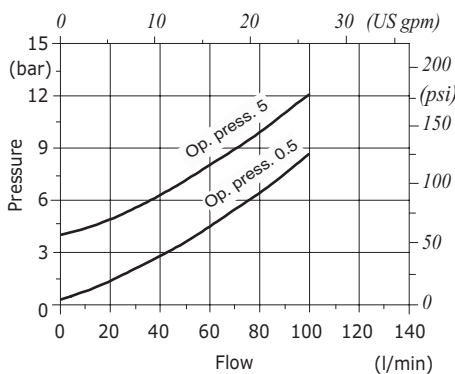

VUI 100 pressure drop vs. flow

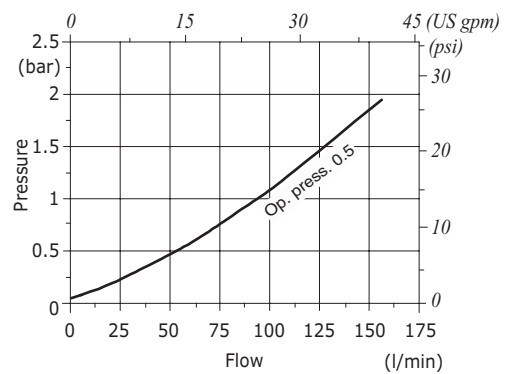



Type VUS/INC check valves

- Ball type

Technical specifications and diagrams are measured with mineral oil ISO VG32 at 50°C (122°F) temperature.

	VUS/INC 14	VUS/INC 38	VUS/INC 12	VUS/INC 34
Nominal flow	18 l/min (4.8 US gpm)	25 l/min (6.6 US gpm)	50 l/min (13.2 US gpm)	78 l/min (20.6 US gpm)
Max. pressure	350 bar (5100 psi)			
Oil leakage	0.25 cm ³ /min (0.015 in ³ /min) at 210 bar (3050 psi)			
Fluid	mineral based oil			
Viscosity	from 10 to 200 cSt			
Max. level of contamination	18/16/13 ISO4406			
Fluid temperature	with NBR seals: from -20°C (-4°F) to 80°C (176°F)			
Environmental temp. for working conditions	-40°C (-40°F) to 100°C (212°F)			
Weight	Steel 0.01 kg (0.02 lb)	0.02 kg (0.04 lb)	0.04 kg (0.09 lb)	0.07 kg (0.15 lb)

NOTE - For different conditions, please contact Walvoil Sales Dpt.



Dimensions

Dimensions are in mm-in

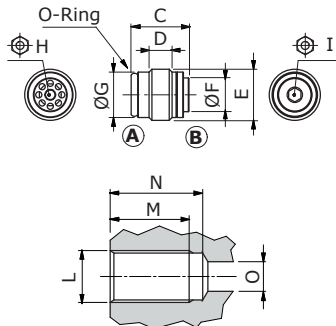

Valve type	ØC	D	E	G	ØG	⊕H	⊕I	O-Ring
VUS/INC14	17-0.67	6-0.24	G 1/4	9.2-0.36	11.3-0.445	3	3	1x9
VUS/INC38	18.5-0.73	7.5-0.29	G 3/8	11-0.43	14.8-0.57	3	4	1.78x10.82
VUS/INC12	23-0.90	9.5-0.37	G 1/2	14-0.55	18.5-0.73	5	6	1.78x14
VUS/INC34	28.5-1.12	14.5-0.57	G 3/4	19-0.75	24-0.94	8	8	2.62x18.72

Valve cavity for	L	M	N	O
VUS/INC14	G 1/4	25-0.98	28-1.1	8-0.31
VUS/INC38	G 3/8	27-.06	30-1.18	9-0.35
VUS/INC12	G 1/2	32-1.26	36-1.42	12-0.47
VUS/INC34	G 3/4	37-1.46	42-1.65	17-0.67

Ordering codes and description composition

VUS/INC **14/Pa0,5**

Port size

Opening pressure (bar)

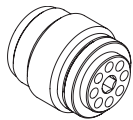

VUS/INC complete valves

TYPE	CODE	DESCRIPTION
VUS/INC 14/Pa0,5	1312110100	Opening pressure 0.5 bar (7.25 psi), G1/4 thread
VUS/INC 38/Pa0,5	1312120100	Opening pressure 0.5 bar (7.25 psi), G3/8 thread
VUS/INC 12/Pa0,5	1312130100	Opening pressure 0.5 bar (7.25 psi), G1/2 thread
VUS/INC 34/Pa0,5	1312140100	Opening pressure 0.5 bar (7.25 psi), G3/4 thread

For different configurations and SAE thread please contact our Sales Dpt.

Rating diagrams

VUS/INC14-38 pressure drop vs. flow
opening pressure 0.5 bar (725 psi)

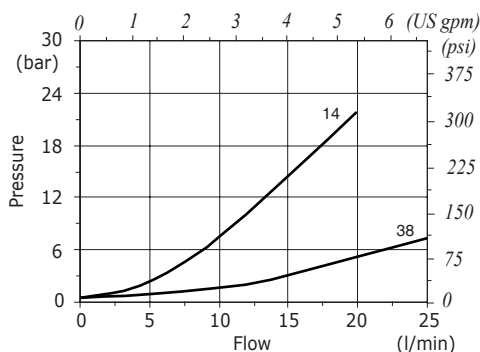

VUS/INC12-34 pressure drop vs. flow
opening pressure 0.5 bar (725 psi)

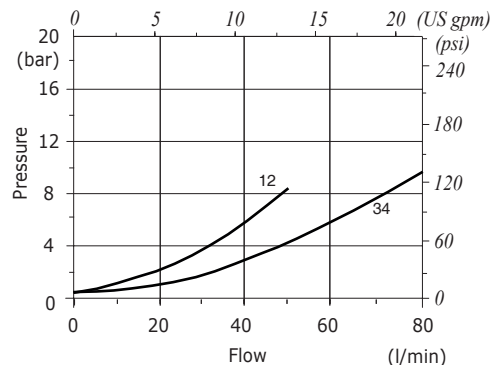



Type VUS/INC/A check valves

- Poppet type

Technical specifications and diagrams are measured with mineral oil ISO VG32 at 50°C (122°F) temperature.

	VUS/INC/A14	VUS/INC/A38	VUS/INC/A12
Nominal flow	20 l/min (5.3 US gpm)	50 l/min (13.2 US gpm)	80 l/min (21.1 US gpm)
Max. pressure	350 bar (5100 psi)		
Oil leakage	0.25 cm ³ /min (0.015 in ³ /min) at 210 bar (3050 psi)		
Fluid	mineral based oil		
Viscosity	from 10 to 200 cSt		
Max. level of contamination	18/16/13 ISO4406		
Fluid temperature	with NBR seals: from -20°C (-4°F) to 80°C (176°F)		
Environmental temperature for working conditions	from -40°C (-40°F) to 100°C (212°F)		
Weight	Steel 0.01 kg (0.02 lb)	0.02 kg (0.04 lb)	0.03 kg (0.06 lb)

NOTE - For different conditions, please contact Walvoil Sales Dpt.



Dimensions

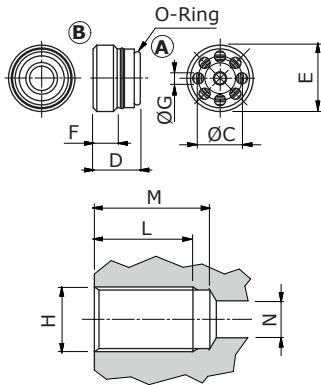

Dimensions are in mm-in

Valve type	ØC	D	E	F	ØG	O-Ring
VUS/INC/A14	8.8 - 0.35	8.8 - 0.35	G 1/4	4.2 - 0.16	2.2 - 0.09	1x8
VUS/INC/A38	10.8 - 0.42	12 - 0.47	G 3/8	7 - 0.27	3 - 0.12	1.5x11
VUS/INC/A12	13.8 - 0.54	14.8 - 0.58	G 1/2	8 - 0.31	3.5 - 0.14	1.78x14

Valve cavity for	H	L	M	N
VUS/INC/A14	G 1/4	21 - 0.83	23.5 - 0.92	7 - 0.27
VUS/INC/A38	G 3/8	24 - 0.94	26.5 - 1.04	9 - 0.35
VUS/INC/A12	G 1/2	27.5 - 1.08	31 - 1.22	12 - 0.47

Ordering codes and description composition

Port size
VUS/INC/A 38/Pa0,5
 Opening pressure (bar)

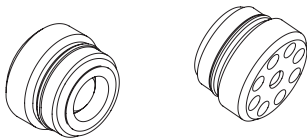

VUS/INC/A complete valves

TYPE	CODE	DESCRIPTION
VUS/INC/A14/Pa0,5	1312210101	Opening pressure 0.5 bar (7.25 psi), G1/4 thread
VUS/INC/A38/Pa0,5	1312220100	Opening pressure 0.5 bar (7.25 psi), G3/8 thread
VUS/INC/A12/Pa0,5	1312230100	Opening pressure 0.5 bar (7.25 psi), G1/2 thread

For different configurations and SAE thread please contact our Sales Dpt.

Rating diagrams

VUS/INC/A14 pressure drop vs. flow
 opening pressure 0.5 bar (725 psi)

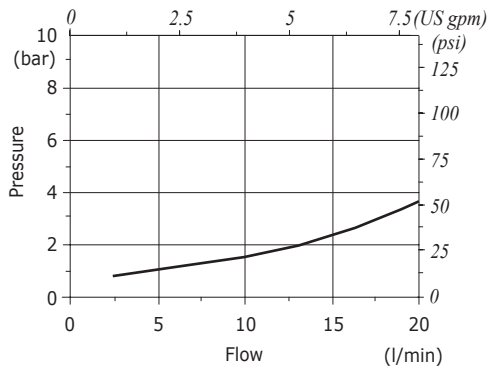

VUS/INC/A38 pressure drop vs. flow
 opening pressure 0.5 bar (725 psi)

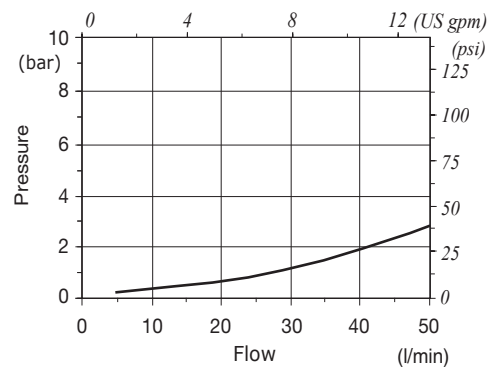

VUS/INC/A12 pressure drop vs. flow
 opening pressure 0.5 bar (725 psi)

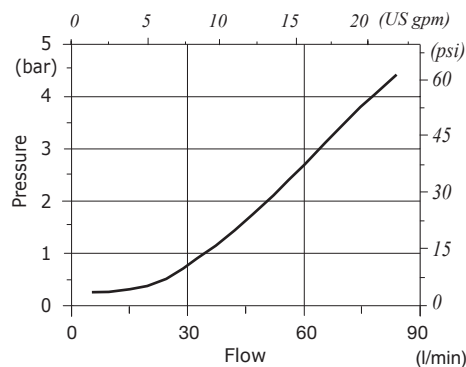

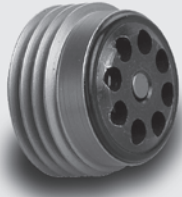

Type VUS/INC/B check valves

- Poppet type

Technical specifications and diagrams are measured with mineral oil ISO VG32 at 50°C (122°F) temperature.

	VUS/INC/B14	VUS/INC/B38	VUS/INC/B12
Nominal flow	20 l/min (5.3 US gpm)	50 l/min (13.2 US gpm)	80 l/min (21.1 US gpm)
Max. pressure	350 bar (5100 psi)		
Oil leakage	0.25 cm ³ /min (0.015 in ³ /min) at 210 bar (3050 psi)		
Fluid	mineral based oil		
Viscosity	from 10 to 200 cSt		
Max. level of contamination	18/16/13 ISO4406		
Fluid temperature	with NBR seals: from -20°C (-4°F) to 80°C (176°F)		
Environmental temperature for working conditions	from -40°C (-40°F) to 100°C (212°F)		
Weight	Steel 0.01 kg (0.02 lb)	0.02 kg (0.04 lb)	0.03 kg (0.06 lb)

NOTE - For different conditions, please contact Walvoil Sales Dpt.



Dimensions

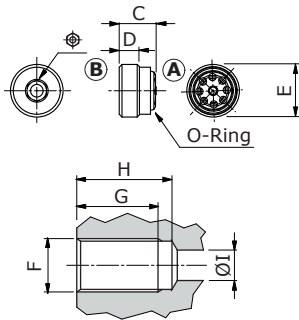

Dimensions are in mm-in

Valve type	ØC	D	E	Ø	O-Ring
VUS/INC/B14	10 - 0.39	6 - 0.24	G 1/4	5	1x9
VUS/INC/B38	11.5 - 0.45	7 - 0.27	G 3/8	6	1.5x10
VUS/INC/B12	13.5 - 0.53	8 - 0.31	G 1/2	8	1.6x14.1

Valve cavity for	F	G	H	ØI
VUS/INC/B14	G 1/4	21.5 - 0.85	24 - 0.94	7 - 0.27
VUS/INC/B38	G 3/8	23 - 0.90	25.5 - 1	9 - 0.35
VUS/INC/B12	G 1/2	28 - 1.10	30.5 - 1.2	12 - 0.47

Ordering codes and description composition

└─ Port size
VUS/INC/B 14/Pa0,5
└─ Opening pressure (bar)

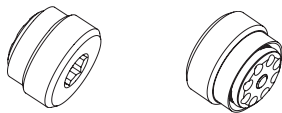

Complete valves

TYPE	CODE	DESCRIPTION
VUS/INC/B14/Pa0,5	1312310100	Opening pressure 0.5 bar (7.25 psi), G1/4 thread
VUS/INC/B38/Pa0,5	1312320100	Opening pressure 0.5 bar (7.25 psi), G3/8 thread
VUS/INC/B12/Pa0,5	1312330100	Opening pressure 0.5 bar (7.25 psi), G1/2 thread

For different configurations and SAE thread please contact our Sales Dpt.

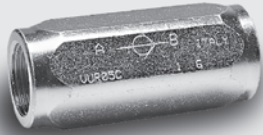

Type VUS check valves

- Ball type

Technical specifications and diagrams are measured with mineral oil ISO VG32 at 50°C (122°F) temperature.

	VUS 14	VUS 38	VUS 12	VUS 34
Nominal flow	15 l/min (3.96 US gpm)	28 l/min (7.4 US gpm)	50 l/min (13.2 US gpm)	80 l/min (21.1 US gpm)
Max. pressure	400 bar (5800 psi)		350 bar (5100 psi)	300 bar (4350 psi)
Oil leakage	0.50 cm ³ /min (0.03 in ³ /min) at 210 bar (3050 psi)			
Fluid	mineral based oil			
Viscosity	from 10 to 200 cSt			
Max. level of contamination	18/16/13 ISO4406			
Fluid temperature	with NBR seals: from -20°C (-4°F) to 80°C (176°F)			
Environmental temp. for working conditions	-40°C (-40°F) to 100°C (212°F)			
Weight	Steel 0.10 kg (0.22 lb)	0.18 kg (0.40 lb)	0.31 kg (0.68 lb)	0.56 kg (1.23 lb)

NOTE - For different conditions, please contact Walvoil Sales Dpt.



Dimensions

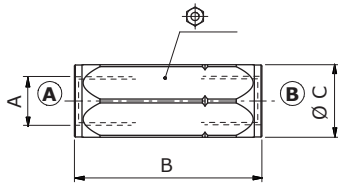

Dimensions are in mm-in

Valve type	A	B	Ø C	⌀
VUS 14	G 1/4	58 - 2.28	21 - 0.83	19
VUS 38	G 3/8	62 - 2.44	27 - 1.05	24
VUS 12	G 1/2	71 - 2.79	33 - 1.30	30
VUS 34	G 3/4	83 - 3.27	40 - 1.57	36

Ordering codes and description composition

Port size | Opening pressure (bar)
VUS14/ Pa4 FO
 - without hole
FO with metering hole

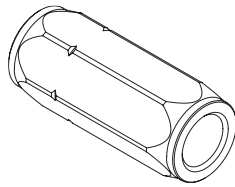

VUS complete valves

TYPE	CODE	DESCRIPTION
VUS14/Pa4	1312010100	Steel body, opening pressure 4 bar (58 psi), G1/4 thread
VUS38/Pa4	1312020100	Steel body, opening pressure 4 bar (58 psi), G3/8 thread
VUS12/Pa4	1312030100	Steel body, opening pressure 4 bar (58 psi), G1/2 thread
VUS34/Pa4	1312040100	Steel body, opening pressure 4 bar (58 psi), G3/4 thread

For different configurations and SAE thread please contact our Sales Dpt.

Rating diagrams

VUS 14 pressure drop vs. flow
opening pressure 4 bar (58 psi)

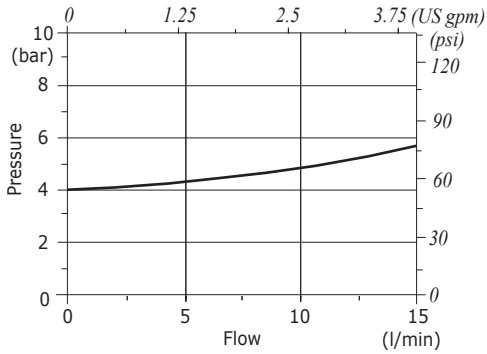

VUS 38 pressure drop vs. flow
opening pressure 4 bar (58 psi)

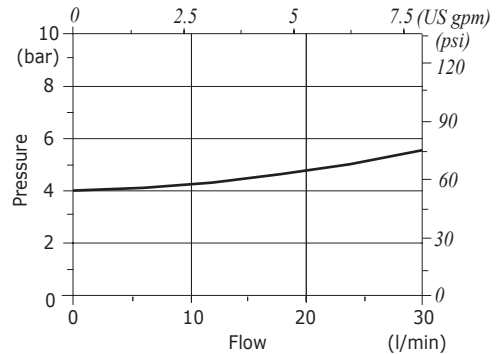

VUS 12 pressure drop vs. flow
opening pressure 4 bar (58 psi)

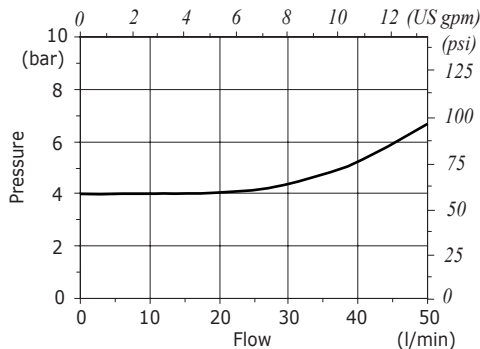

VUS 34 pressure drop vs. flow
opening pressure 4 bar (58 psi)

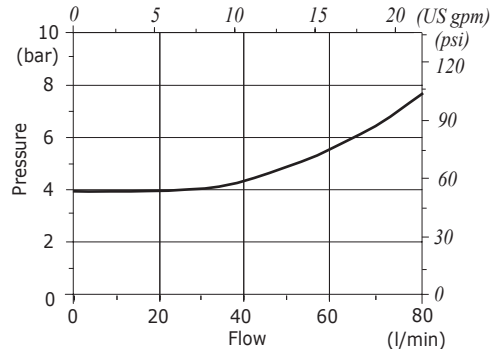



Type VUC check valves

- Poppet type

Technical specifications and diagrams are measured with mineral oil ISO VG32 at 50°C (122°F) temperature.

	VUC 14	VUC 38	VUC 12	VUC 34	VUC 100	VUC 114	VUC 112	
Nominal flow	30 l/min (7.9 US gpm)	50 l/min (13.2 US gpm)	90 l/min (23.8 US gpm)	130 l/min (34.3 US gpm)	180 l/min (47.6 US gpm)	250 l/min (66 US gpm)	380 l/min (100 US gpm)	
Max. pressure	400 bar (5800 psi)		350 bar (5100 psi)	300 bar (4350 psi)	270 bar (3900 psi)	250 bar (3600 psi)	200 bar (2900 psi)	
Oil leakage	0.25 cm ³ /min (0.015 in ³ /min) at 210 bar (3050 psi)							
Fluid	mineral based oil							
Viscosity	from 10 to 200 cSt							
Max. level of contamination	18/16/13 ISO4406							
Fluid temperature	with NBR seals: from -20°C (-4°F) to 80°C (176°F)							
Environmental temp. for working conditions	-40°C (-40°F) to 100°C (212°F)							
Weight	Steel	0.10 kg (0.22 lb)	0.18 kg (0.40 lb)	0.31 kg (0.68 lb)	0.56 kg (1.23 lb)	0.91 kg (2.01 lb)	1.48 kg (3.26 lb)	2.37 kg (5.22 lb)

NOTE - For different conditions, please contact Walvoil Sales Dpt.



Dimensions

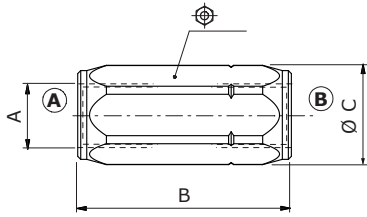

Dimensions are in mm-in

Valve type	A	B	Ø C	⊕
VUC 14	G 1/4	58 - 2.28	21 - 0.83	19
VUC 38	G 3/8	62 - 2.44	27 - 1.05	24
VUC 12	G 1/2	71 - 2.79	33 - 1.30	30
VUC 34	G 3/4	83 - 3.27	40 - 1.57	36
VUC 100	1	106 - 4.17	59 - 2.32	45
VUC 114	G 1 1/4	127 - 5	63 - 2.48	55
VUC 112	G 1 1/2	138 - 5.43	74 - 2.91	65

Ordering codes and description composition

Port size Opening pressure (bar)

VUC14/Pa0,5 FO

- without hole
FO with metering hole

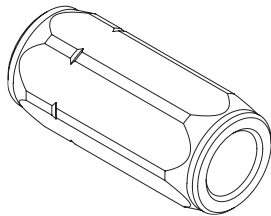

VUC complete valves

TYPE	CODE	DESCRIPTION
VUC14/Pa0,5	1312510100	Steel body, opening pressure 0.5 bar (7.25 psi), G1/4 thread
VUC38/Pa0,5	1312520100	Steel body, opening pressure 0.5 bar (7.25 psi), G3/8 thread
VUC12/Pa0,5	1312530100	Steel body, opening pressure 0.5 bar (7.25 psi), G1/2 thread
VUC34/Pa0,5	1312540100	Steel body, opening pressure 0.5 bar (7.25 psi), G3/4 thread
VUC100/Pa0,5	1312550100	Steel body, opening pressure 0.5 bar (7.25 psi), G1 thread
VUC114/Pa0,5	1312560100	Steel body, opening pressure 0.5 bar (7.25 psi), G1 1/4 thread
VUC112/Pa0,5	1312570100	Steel body, opening pressure 0.5 bar (7.25 psi), G1 1/2 thread

For different configurations and SAE thread please contact our Sales Dpt.

Rating diagrams

VUC14-VUC38 pressure drop vs. flow
 opening pressure 0.5 bar (7.25 psi)

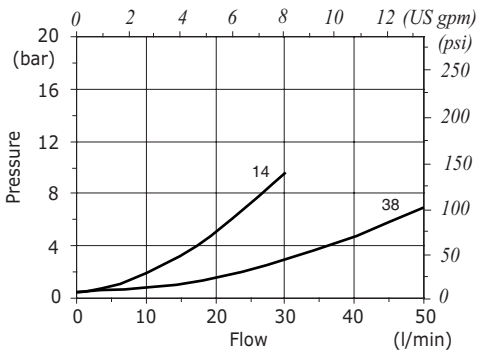

VUC12-VUC34-VUC100 pressure drop vs. flow
 opening pressure 0.5 bar (7.25 psi)

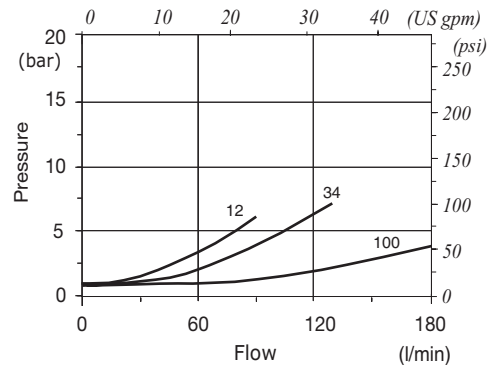

VUC114-VUC112 pressure drop vs. flow
 opening pressure 0.5 bar (7.25 psi)

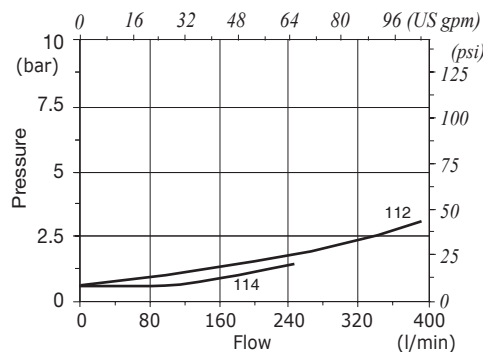

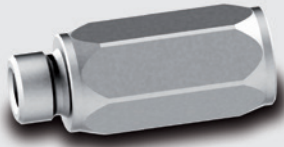

Type VUC/M check valves

- Poppet type

Technical specifications and diagrams are measured with mineral oil ISO VG32 at 50°C (122°F) temperature.

	VUC/M 14	VUC/M 38	VUC/M 12	VUC/M 34	VUC/M 100	VUC/M 114	
Nominal flow	30 l/min (7.9 US gpm)	50 l/min (13.2 US gpm)	90 l/min (23.8 US gpm)	130 l/min (34.3 US gpm)	180 l/min (47.6 US gpm)	250 l/min (66 US gpm)	
Max. pressure	400 bar (5800 psi)		350 bar (5100 psi)	300 bar (4350 psi)	270 bar (3900 psi)	250 bar (3600 psi)	
Oil leakage	0.25 cm ³ /min (0.015 in ³ /min) at 210 bar (3050 psi)						
Fluid	mineral based oil						
Viscosity	from 10 to 200 cSt						
Max. level of contamination	18/16/13 ISO4406						
Fluid temperature	with NBR seals: from -20°C (-4°F) to 80°C (176°F)						
Environmental temp. for working conditions	-40°C (-40°F) to 100°C (212°F)						
Weight	Steel	0.10 kg (0.22 lb)	0.18 kg (0.40 lb)	0.31 kg (0.68 lb)	0.56 kg (1.23 lb)	0.91 kg (2.01 lb)	1.48 kg (3.26 lb)

NOTE - For different conditions, please contact Walvoil Sales Dpt.



Dimensions

Dimensions are in mm-in

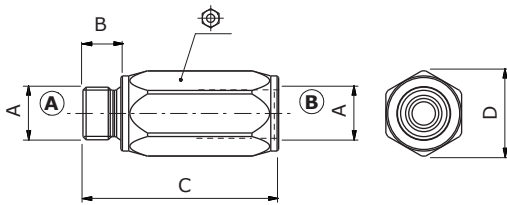

Valve type	A	B	C	D	⌀
VUC/M 14	G 1/4	12 - 0.47	58 - 2.28	21 - 0.83	19
VUC/M 38	G 3/8	12 - 0.47	62 - 2.44	27 - 1.05	24
VUC/M 12	G 1/2	14 - 0.55	71 - 2.79	33 - 1.30	30
VUC/M 34	G 3/4	16 - 0.63	76 - 2.99	40 - 1.57	36
VUC/M 100	1	18 - 0.71	106 - 4.17	59 - 2.32	45
VUC/M 114	G 1 1/4	20 - 0.78	127 - 5	63 - 2.48	55

Ordering codes and description composition

Port size — Opening pressure (bar)
VUC/M 14/Pa0,5

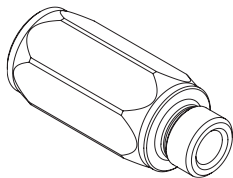

VUC/M complete valves

TYPE	CODE	DESCRIPTION
VUC/M14/Pa0,5	1312610100	Steel body, opening pressure 0.5 bar (7.25 psi), G1/4 thread
VUC/M38/Pa0,5	1312620100	Steel body, opening pressure 0.5 bar (7.25 psi), G3/8 thread
VUC/M12/Pa0,5	1312630100	Steel body, opening pressure 0.5 bar (7.25 psi), G1/2 thread
VUC/M34/Pa0,5	1312640100	Steel body, opening pressure 0.5 bar (7.25 psi), G3/4 thread
VUC/M100/Pa0,5	1312650100	Steel body, opening pressure 0.5 bar (7.25 psi), G1 thread
VUC/M114/Pa0,5	1312660100	Steel body, opening pressure 0.5 bar (7.25 psi), G1 1/4 thread

For different configurations and SAE thread please contact our Sales Dpt.

Rating diagrams

VUC/M14-38-12 pressure drop vs. flow
 opening pressure 0.5 bar (7.25 psi)

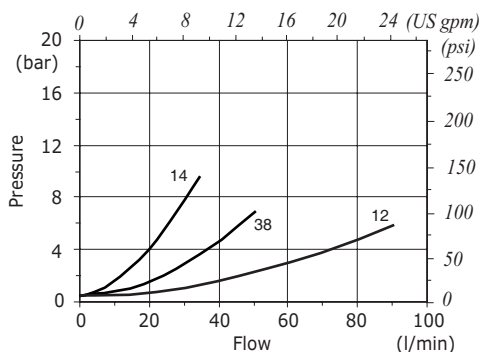

VUC/M34-100-114 pressure drop vs. flow
 opening pressure 0.5 bar (7.25 psi)

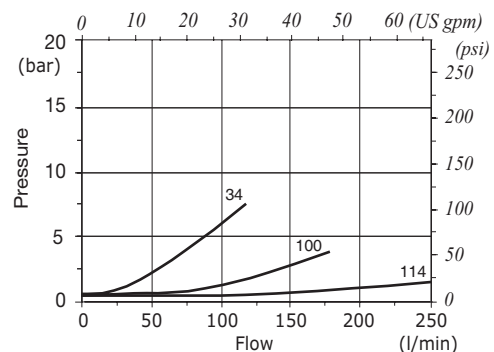

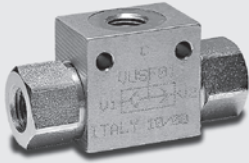

Type VT shuttle valves

- Shuttle valves
- Ball type

Technical specifications and diagrams are measured with mineral oil ISO VG32 at 50°C (122°F) temperature.

	VT 14	VT 38	VT 12	VT 34	VT 100	
Nominal flow	35 l/min (9.3 US gpm)	50 l/min (13.2 US gpm)	90 l/min (23.8 US gpm)	140 l/min (37 US gpm)	180 l/min (47.6 US gpm)	
Max. pressure	350 bar (5100 psi)					
Fluid	mineral based oil					
Viscosity	from 10 to 200 cSt					
Max. level of contamination	18/16/13 ISO4406					
Fluid temperature	with NBR seals: from -20°C (-4°F) to 80°C (176°F)					
Environmental temp. for working conditions	-40°C (-40°F) to 100°C (212°F)					
Weight	Steel	0.27 kg (0.59 lb)	0.464 kg (1.02 lb)	0.74 kg (1.63 lb)	1.406 kg (3.1 lb)	1.87 kg (4.12 lb)

NOTE - For different conditions, please contact Walvoil Sales Dpt.

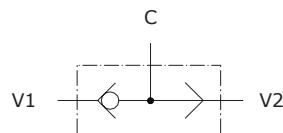

Dimensions

Dimensions are in mm-in

Valve type	A	B	C	D	E	F	G	H	I	L
VT 14	69 2.71	36 1.42	25 0.98	35 1.38	22.5 0.88	7.5 0.29	G 1/4	25 0.98	5.5 0.22	22
VT 38	75 2.95	45 1.77	30 1.18	45 1.77	30 1.18	8 0.31	G 3/8	29 1.14	6.5 0.25	27
VT 12	94 3.7	57 2.24	35 1.38	50 1.97	32 1.26	9 0.35	G 1/2	36 1.42	5.5 0.22	30
VT 34	100 3.94	65 2.56	50 1.97	60 2.36	37.5 1.48	6.5 0.25	G 3/4	50 1.97	6.5 0.25	41
VT 100	126 4.96	80 3.15	50 1.97	80 3.15	54.5 2.14	11 0.43	G 1	60 2.36	10.5 0.41	46

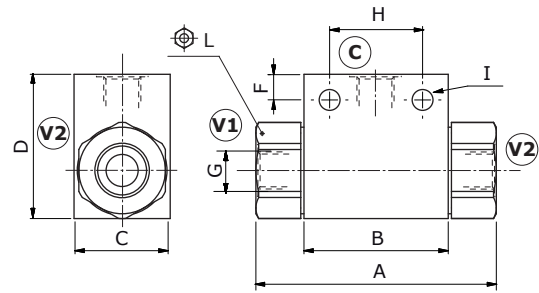

Ordering codes and description composition

Port size
VT 14

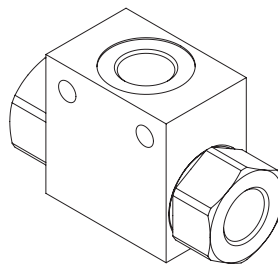

1 VT complete valves

TYPE	CODE	DESCRIPTION
VT14	1323012100	Steel body, G1/4 ports
VT38	1323022100	Steel body, G3/8 ports
VT12	1323032100	Steel body, G1/2 ports
VT34	1323042100	Steel body, G3/4 ports
VT100	1323052100	Steel body, G1 ports

For different configurations and SAE thread please contact our Sales Dpt.

Rating diagrams

VT14-38 pressure drop vs. flow

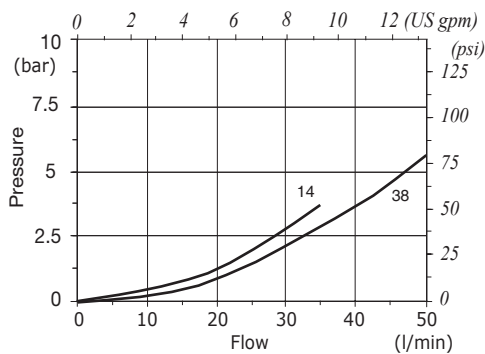

VT12-34-100 pressure drop vs. flow

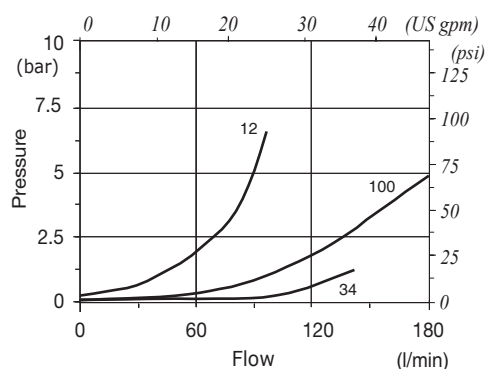

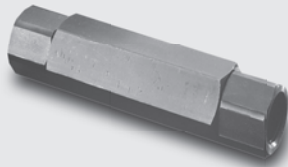

Type VBD-VBD/VP check valves

- Double acting

Technical specifications and diagrams are measured with mineral oil of 46 cSt viscosity at 40°C (104°F) temperature.

	VBD/VP 38	VBD 38	VBD 12	VBD 34
Nominal flow	20 l/min (5.2 US gpm)	40 l/min (10.5 US gpm)	60 l/min (15.8 US gpm)	90 l/min (23.8 US gpm)
Max. pressure	350 bar (5100 psi)			
Oil leakage	0.5 cm ³ /min (0.030 in ³ /min) at 210 bar (3050 psi): at 75% of pressure setting			
Fluid	mineral based oil			
Viscosity	from 10 to 200 cSt			
Max. level of contamination	18/16/13 ISO4406			
Fluid temperature	with NBR seals: from -20°C (-4°F) to 80°C (176°F)			
Environmental temp. for working conditions	from -40°C (-40°F) to 100°C (212°F)			
Weight	Steel 0.21 kg (0.46 lb)	0.46 kg (1.01 lb)	0.54 kg (1.19 lb)	1.51 kg (3.33 lb)

NOTE - For different conditions, please contact Walvoil Sales Dpt.

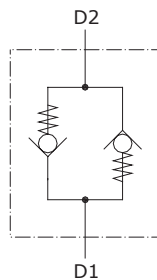

Dimensions

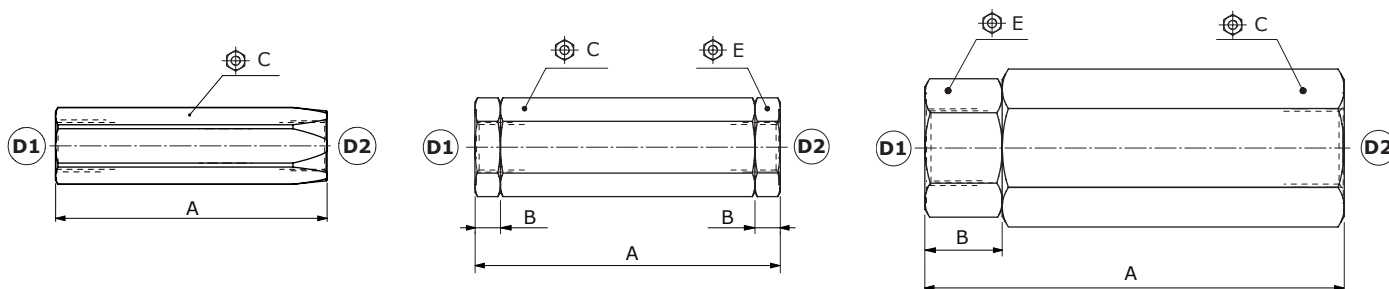

Valve type	All ports	Valve type	A	B	⌀C	⌀E
VBD 38/VP	G 3/8	VBD 38/VP	87-3.43	/	22	/
VBD 38	G 3/8	VBD 38	102-4.02	8.5-0.335	30	27
VBD 12	G 1/2	VBD 12	129-5.08	22-0.87	30	27
VBD 34	G 3/4	VBD 34	141-5.55	26-1.02	46	46
Valve type	All ports	Valve type	A	B	⌀C	⌀E
VBD 38/VP/SAE	SAE8	VBD 38/VP/SAE	87-3.43	/	22	/
VBD 38/SAE	SAE8	VBD 38/SAE	102-4.02	8.5-0.335	30	27

Ordering codes and description composition

Port size
VBD 38/Pa0.5-8
 Opening pressure (bar)

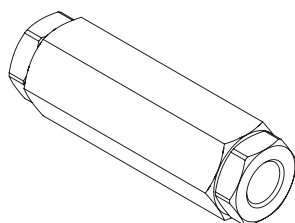

Port size
VBD/VP 38/Pa0.5-15
 Opening pressure (bar)

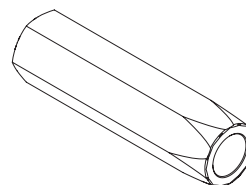

VBD complete valves

TYPE	CODE	DESCRIPTION
VBD 38/Pa0.5-8	1313020100	Steel body, opening pressure 0.5 bar (7.25 psi) and 8 bar (116 psi), G3/8 ports
VBD 12/Pa0.5-8	1313030100	Steel body, opening pressure 0.5 bar (7.25 psi) and 8 bar (116 psi), G1/2 ports
VBD 34/Pa0.5-8	1313040100	Steel body, opening pressure 0.5 bar (7.25 psi) and 8 bar (116 psi), G3/4 ports
VBD 38/Pa0.5-8/SAE	1313020100	Steel body, opening pressure 0.5 bar (7.25 psi) and 8 bar (116 psi), G3/8 ports

For configurations with special opening pressure or SAE threads please contact our Sales Dpt.

VBD/VP complete valves

TYPE	CODE	DESCRIPTION
Only G3/8 port configuration		
VBD/VP 38/Pa0.5-15	1313020902	Steel body, opening pressure 0.5 bar (7.25 psi) and 15 bar (217 psi)
VBD/VP 38/Pa0.5-20	1313020907	Steel body, opening pressure 0.5 bar (7.25 psi) and 20 bar (290 psi)
VBD/VP 38/Pa0.5-40	1313020900	Steel body, opening pressure 0.5 bar (7.25 psi) and 40 bar (580 psi)
VBD/VP 38/Pa0.5-60	1313020905	Steel body, opening pressure 0.5 bar (7.25 psi) and 60 bar (870 psi)
VBD/VP 38/Pa0.5-80	1313020901	Steel body, opening pressure 0.5 bar (7.25 psi) and 80 bar (1160 psi)

SAE8 port configuration

VBD/VP 38/Pa0.5-40/SAE	1313020909	Steel body, opening pressure 0.5 bar (7.25 psi) and 40 bar (580 psi)
------------------------	------------	--

For configurations with special opening pressure or SAE threads please contact our Sales Dpt.

Rating diagrams

VBD/VP 38 pressure drop vs. flow

Opening pressure 0.5 bar (7.25 psi) and 15 bar (217 psi)

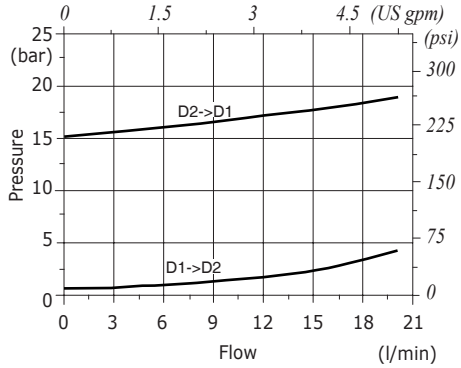

VBD 38 pressure drop vs. flow

Opening pressure 0.5 bar (7.25 psi) and 8 bar (116 psi)

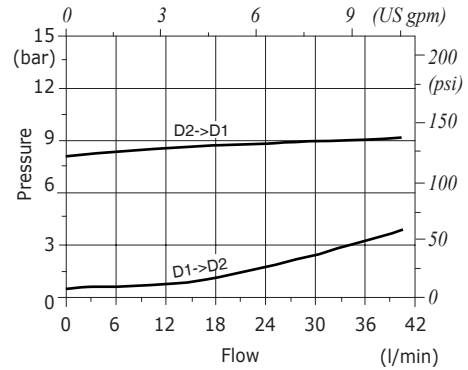

VBD 12 pressure drop vs. flow

Opening pressure 0.5 bar (7.25 psi) and 8 bar (116 psi)

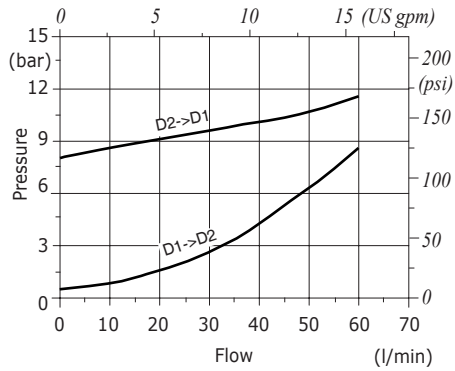

VBD 34 pressure drop vs. flow

Opening pressure 0.5 bar (7.25 psi) and 8 bar (116 psi)

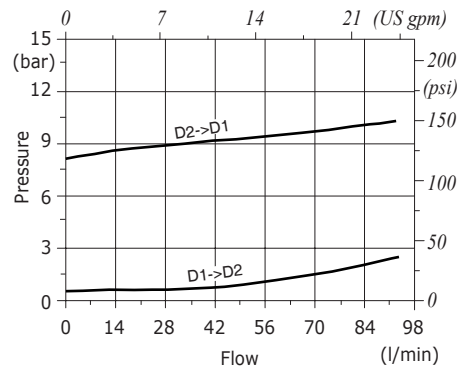



Type VB check valves

- Hose burst valve
- Automatic stop for sudden flow increase

Technical specifications and diagrams are measured with mineral oil ISO VG32 at 40°C (104°F) temperature.

	VB 14	VB 38	VB 12	VB 34	VB 100	
Nominal flow	30 l/min (7.9 US gpm)	45 l/min (11.9 US gpm)	65 l/min (17.2 US gpm)	170 l/min (44.9 US gpm)	225 l/min (59.4 US gpm)	
Max. pressure	350 bar (5100 psi)					
Fluid	mineral based oil					
Viscosity	10-200 cSt					
Max. level of contamination	18/16/13 ISO4406					
Fluid temperature	with NBR seals from -20°C (-4°F) to 80°C (176°F)					
Environmental temp. for working conditions	from -40°C (-40°F) to 100°C (212°F)					
Weight	steel	0.01 kg (0.022 lb)	0.015 kg (0.033 lb)	0.025 kg (0.055 lb)	0.045 kg (0.099 lb)	0.098 kg (0.22 lb)

NOTES - Replace the valve after each operation. For different conditions, please contact Walvoil Sales Dpt.

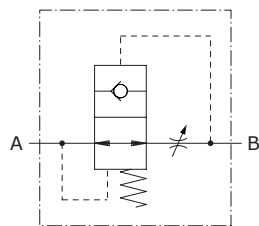

With metering hole

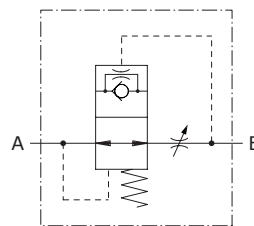

NOTE - For valve with optional calibration hole, please contact our Sales Dpt.

Dimension

Valve type	All ports
VB 14	G 1/4
VB 38	G 3/8
VB 12	G 1/2
VB 34	G 3/4
VB 100	G 1

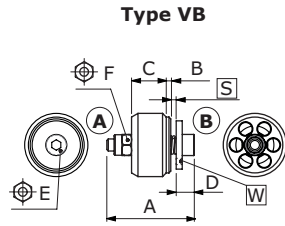

Housing type VB/M

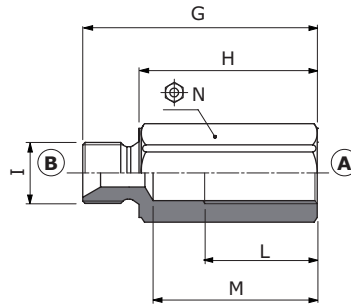

Housing type VB/F

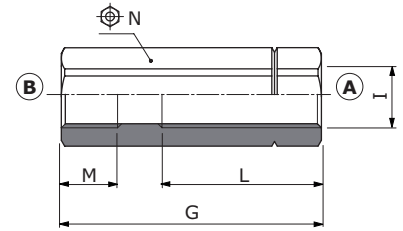

Dimensions are in mm-in

Valve type	A	B	C	D	E	F
VB 14	19 0.75	1 0.039	7 0.27	5 0.2	5.5	2.5
VB 38	23 0.9	1.5 0.059	9.5 0.37	5 0.2	5.5	2.5
VB 12	29 1.14	1.5 0.059	11.5 0.45	6 0.23	7	3
VB 34	34 1.34	2.5 0.098	15.5 0.61	6 0.23	7	3
VB 100	40 1.57	1.5 0.059	18.5 0.73	8.5 0.33	8	4

Housing type	G	H	I	L	M	N	
M	01	50 - 1.97	38 - 1.50	G 1/4	23 - 0.9	31 - 1.22	19
	02	60 - 2.36	48 - 1.89	G 3/8	30 - 1.18	43 - 1.69	22
	03	63 - 2.48	49 - 1.93	G 1/2	33 - 1.30	45 - 1.77	27
	04	75 - 2.95	59 - 2.32	G 3/4	36 - 1.42	50 - 1.97	32
	05	88 - 3.46	70 - 2.75	G 1	46 - 1.81	60 - 2.36	41
F	01	50 - 1.97	-	G 1/4	20 - 0.79	12 - 0.47	19
	02	58 - 2.28	-	G 3/8	27 - 1.06	14 - 0.55	22
	03	60 - 2.36	-	G 1/2	33 - 1.30	19 - 0.75	27
	04	76 - 2.99	-	G 3/4	36 - 1.42	19 - 0.75	32
	05	85 - 3.35	-	G 1	46 - 1.81	18 - 0.71	41

NOTE - The setting of **S** is recommended to be 1.5 - 2 times the maximum descent flow
W= optional calibration hole

Ordering codes and description composition

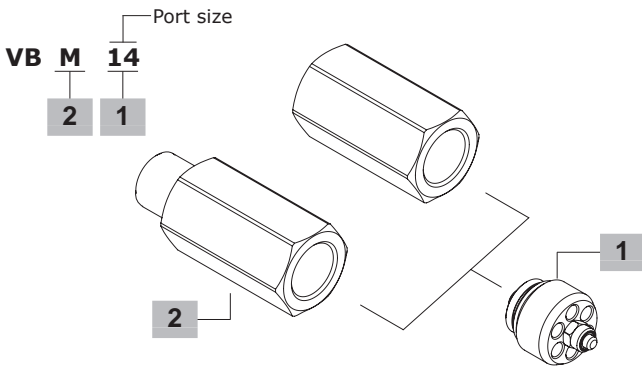

VB complete valves

TYPE	CODE	DESCRIPTION
VB/M 14 S=1	1431210100	Male-female G1/4 ports
VB/F 14 S=1	1431110100	Female-female G1/4 ports
VB/M 38 S=1,5	1431220100	Male-female G3/8 ports
VB/F 38 S=1,5	1431120100	Female-female G3/8 ports
VB/M 12 S=1,8	1431230100	Male-female G1/2 ports
VB/F 12 S=1,8	1431130100	Female-female G1/2 ports
VB/M 34 S=2,2	1431240100	Male-female G3/4 ports
VB/F 34 S=2,2	1431140100	Female-female G3/4 ports
VB/M 100 S=2,6	1431250100	Male-female G1 ports
VB/F 100 S=2,6	1431150100	Female-female G1 ports

For different configurations, SAE thread and valve with optional calibration hole, please contact our Sales Dpt.

1 Cartridge

TYPE	CODE	DESCRIPTION
VB 14 S=1	1431010100	G1/4, "S" standard setting 1, standard flow rate 18.5 l/min (4.89 US gpm)
VB 38 S=1,5	1431020100	G3/8, "S" standard setting 1.5, standard flow rate 35.5 l/min (9.38 US gpm)
VB 12 S=1,8	1431030100	G1/2, "S" standard setting 1.9, standard flow rate 60 l/min (15.85 US gpm)
VB 34 S=2,2	1431040100	G3/4, "S" standard setting 2.2, standard flow rate 149 l/min (39.36 US gpm)
VB 100 S=2,6	1431050100	G1, "S" standard setting 2.6, standard flow rate 190 l/min (50.19 US gpm)

For different configurations or SAE thread please contact our Sales Dpt.

2 Housing

M-F (male-female) or F-F (female-female) steel housing					
TYPE	CODE	DESCR.	TYPE	CODE	DESCR.
MF14	CMFVUBA01	G1/4, M-F	MF04	CMFVUBA04	G3/4, M-F
FF14	CFFVUBA-VSC01	G1/4, F-F	FF04	CFFVUBA04	G3/4, F-F
MF02	CMFVUBA02	G3/8, M-F	MF05	CMFVUBA05	G1, M-F
FF02	CFFVUBA02	G3/8, F-F	FF05	CFFVUBA04	G1, F-F
MF03	CMFVUBA03	G1/2, M-F			
FF03	CFFVUBA03	G1/2, F-F			

VB G 1/4 flow vs. setting of S

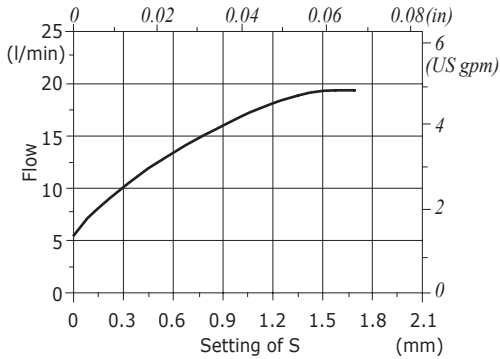

VB G 3/8 flow vs. setting of S

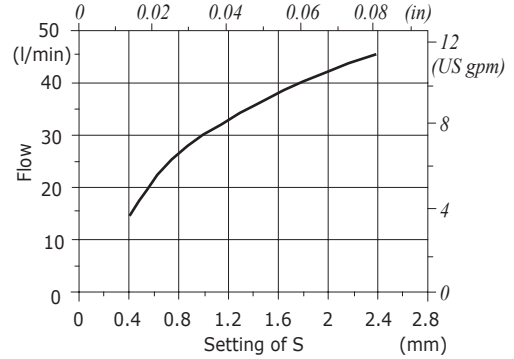

VB G 1/2 flow vs. setting of S

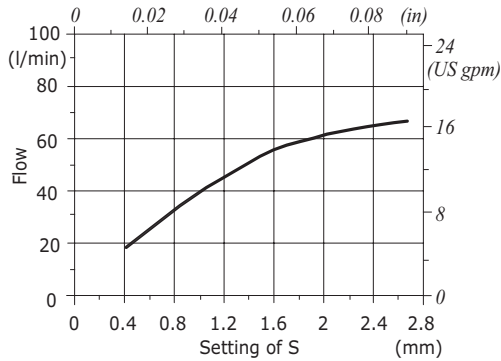

VB G 3/4 flow vs. setting of S

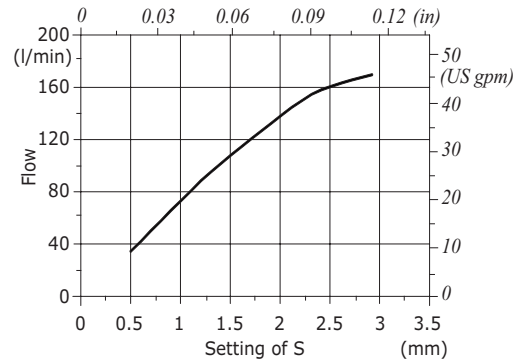

VB G 1 flow vs. quote S

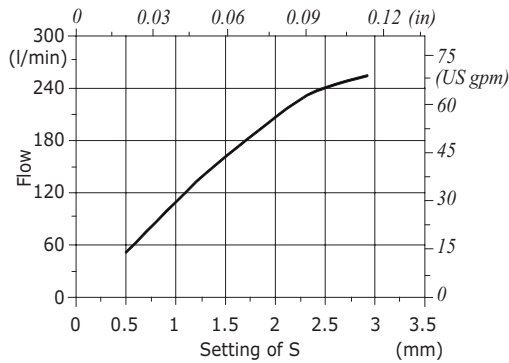



Type VUPSL pilot operated check valves

- Single acting

Technical specifications and diagrams are measured with mineral oil ISO VG32 at 50°C (122°F) temperature.

	VUPSL 14 ⁽¹⁾	VUPSL 38	VUPSL 12	VUPSL 34	VUPSL 100
Nominal flow	25 l/min (6.6 US gpm)	40 l/min (10.6 US gpm)	60 l/min (15.9 US gpm)	90 l/min (23.8 US gpm)	130 l/min (34.3 US gpm)
Max. pressure		350 bar (5100 psi)		300 bar (4350 psi)	260 bar (3750 psi)
Oil leakage	0.25 cm ³ /min (0.015 in ³ /min) at 210 bar (3050 psi)				
Fluid	mineral based oil				
Viscosity	from 10 to 200 cSt				
Max. level of contamination	18/16/13 ISO4406				
Fluid temperature	with NBR seals: from -28°C (-18°F) to 100°C (212°F)				
Environmental temp. for working conditions	from -40°C (-40°F) to 100°C (212°F)				
Weight	steel 0.69 kg (1.52 lb)	0.93 kg (2.05 lb)	1.08 kg (2.38 lb)	2.316 kg (5.10 lb)	2.355 kg (5.19 lb)

NOTE - For different conditions, please contact Walvoil Sales Dpt.

⁽¹⁾ VUPSL14 valve require the bonded seal cod. 440068 on port P.

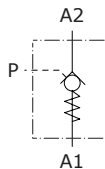

Dimensions

Valve type	P	D
VUPSL 14	G1/4	G1/4
VUPSL 38	G1/4	G3/8
VUPSL 12	G1/4	G1/2
VUPSL 34	G1/4	G3/4
VUPSL 100	G1/4	G1

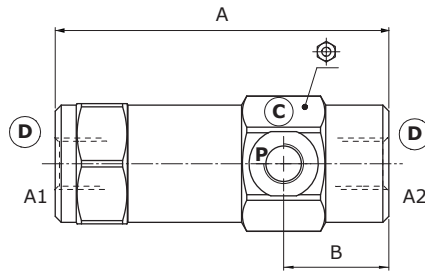

Dimensions are in mm-in

Valve type	A	B	⌀
VUPSL 14	103-4.05	32.5-1.28	36
VUPSL 38	111-4.37	35-1.38	40
VUPSL 12	122-4.8	38-1.5	42
VUPSL 34	145.5-5.73	44.5-1.75	55
VUPSL 100	164-6.46	44.5-1.75	55

Ordering codes and description composition

Port size Opening pressure
VUPSL 38/p6 /Pa1
 Pilot ratio

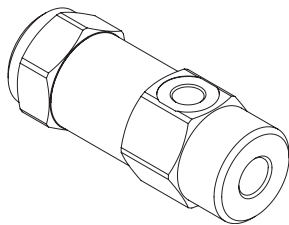

VUPSL complete valves

With steel body

TYPE	CODE	DESCRIPTION
VUPSL 14/p9,5/Pa1	1401010100	G1/4 port, pilot ratio 1:9.5
VUPSL 38/p6/Pa1	1401020100	G3/8 port, pilot ratio 1:6
VUPSL 12/p4,3/Pa1	1401030100	G1/2 port, pilot ratio 1:4.3
VUPSL 34/p4,4/Pa1	1401040100	G3/4 port, pilot ratio 1:4.4
VUPSL 100/p3,5/Pa1	1401050100	G1" port, pilot ratio 1:3.5

For different configurations or SAE thread please contact our Sales Dpt.

Rating diagrams

VUPSL 14 pressure drop vs. flow

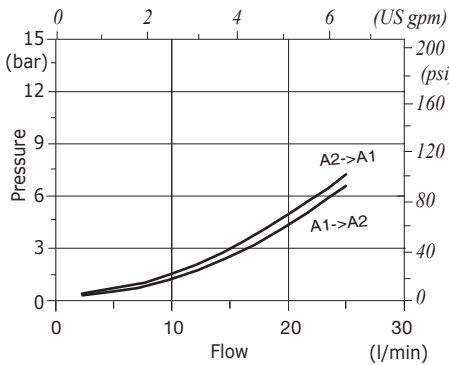

VUPSL 38 pressure drop vs. flow

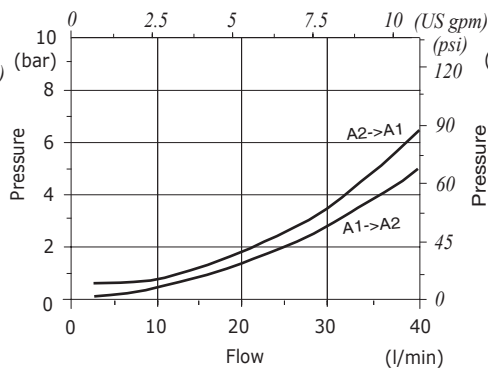

VUPSL 12 pressure drop vs. flow

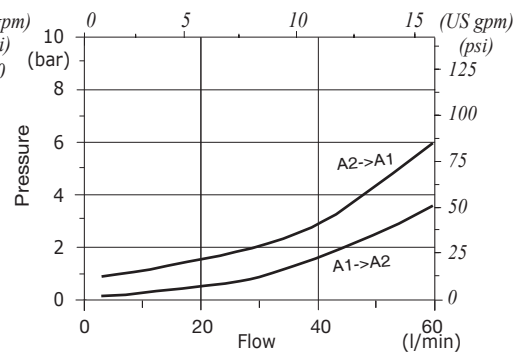

VUPSL 34 pressure drop vs. flow

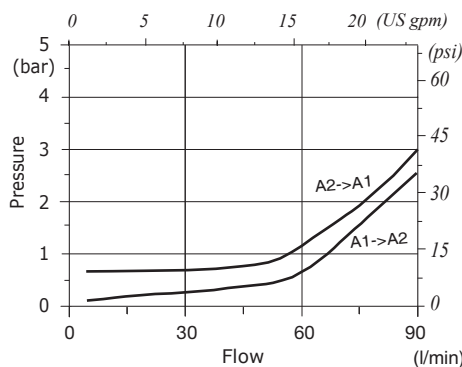

VUPSL 100 pressure drop vs. flow

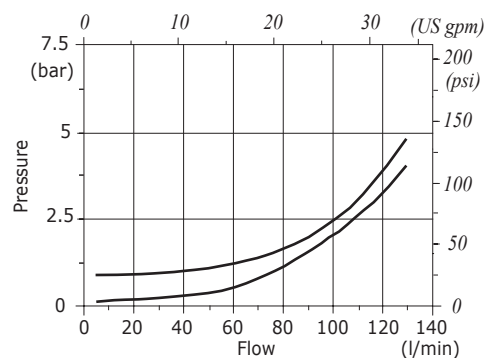



Type VBPSL pilot operated check valves

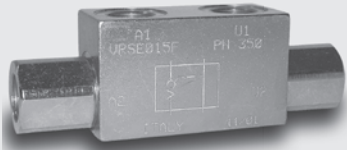

- Single acting

Technical specifications and diagrams are measured with mineral oil ISO VG32 at 50°C (122°F) temperature.

	VBPSL 14	VBPSL/VP 38	VBPSL 38	VBPSL/VP 12	VBPSL 12	VBPSL 34	
Nominal flow	30 l/min (7.9 US gpm)		50 l/min (13.2 US gpm)		80 l/min (21.1 US gpm)	120 l/min (31.7 US gpm)	
Max. pressure	350 bar (5100 psi)		300 bar (4350 psi)		300 bar (4350 psi)		
Oil leakage	0.25 cm ³ /min (0.015 in ³ /min) at 210 bar (3050 psi)						
Fluid	mineral based oil						
Viscosity	from 10 to 200 cSt						
Max. level of contamination	18/16/13 ISO4406						
Fluid temperature	with NBR seals: from -20°C (-4°F) to 80°C (176°F)						
Environmental temp. for working conditions	-40°C (-40°F) to 100°C (212°F)						
Weight	steel	0.68 kg (1.50 lb)	0.63 kg (1.39 lb)	0.97 kg (2.14 lb)	0.90 kg (1.98 lb)	1.69 kg (3.72 lb)	3.06 kg (6.75 lb)

NOTE - For different conditions, please contact Walvoil Sales Dpt.

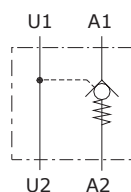

Dimensions

Valve type	All ports
VBPSL 14	G1/4
VBPSL/VP 38	G3/8
VBPSL 38	G3/8
VBPSL/VP 12	G1/2
VBPSL 12	G1/2
VBPSL 34	G3/4

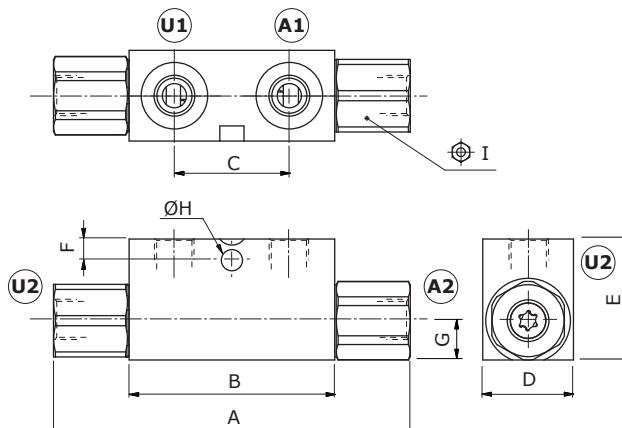

Dimensions are in mm-in

Valve type	A max.	B	C	D	E	F	G	H	⊕ I
VBPSL 14	118-4.64	68-2.68	38-1.50	30-1.18	40-1.57	7-0.27	13-0.51	8-0.31	24
VBPSL/VP 38	118-4.64	68-2.68	38-1.50	30-1.18	40-1.57	7-0.27	13-0.51	8-0.31	24
VBPSL 38	144-5.67	80-3.15	40-1.57	30-1.18	50-1.97	15-0.59	16-0.63	8.5-0.33	27
VBPSL/VP 12	144-5.67	80-3.15	40-1.57	30-1.18	50-1.97	15-0.59	16-0.63	8.5-0.33	27
VBPSL 12	171-6.73	90-3.54	40-1.57	40-1.57	60-2.36	15-0.59	20-0.79	8.5-0.33	30
VBPSL 34	196 ⁽¹⁾ -7.72 ⁽¹⁾	107-4.21	60-2.36	50-1.97	70-2.75	16-0.63	23-0.90	8.5-0.33	41

NOTE - ⁽¹⁾ only for 04 SAE 208

Ordering codes and description composition

Port size
Opening pressure
VBPSL 14 / p4,5 / Pa4 / ac
Pilot ratio

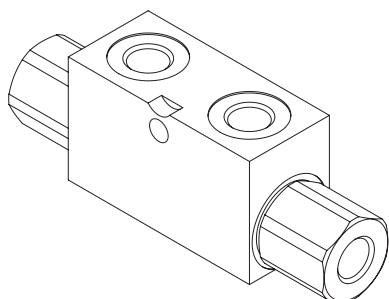

VBPSL complete valves

Steel body

TYPE	CODE	DESCRIPTION
VBPSL 14/p4,5/Pa4/ac	1410112100	G1/4 port, pilot ratio 1:4.5, opening press. 4 bar (58 psi)
VBPSL 38/p4/Pa4/ac	1410122100	G3/8 port, pilot ratio 1:4, opening press. 4 bar (58 psi)
VBPSL/VP 38/p4,5/Pa4/ac	1410122101	G3/8 port, pilot ratio 1:4.5, opening press. 4 bar (58 psi)
VBPSL 12/p4/Pa4/ac	1410132100	G1/2 port, pilot ratio 1:4, opening press. 4 bar (58 psi)
VBPSL/VP 12/p4/Pa4/ac	1410132101	G1/2 port, pilot ratio 1:4, opening press. 4 bar (58 psi)
VBPSL 34/p4/Pa4/ac	1410142100	G3/4 port, pilot ratio 1:4, opening press. 4 bar (58 psi)

For different configurations or SAE thread please contact our Sales Dpt.

VBPSL 14 pressure drop vs. flow

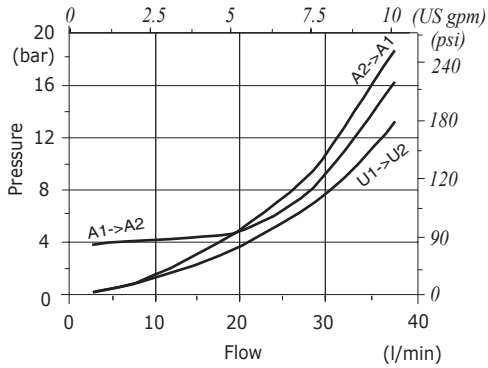

VBPSL 38 pressure drop vs. flow

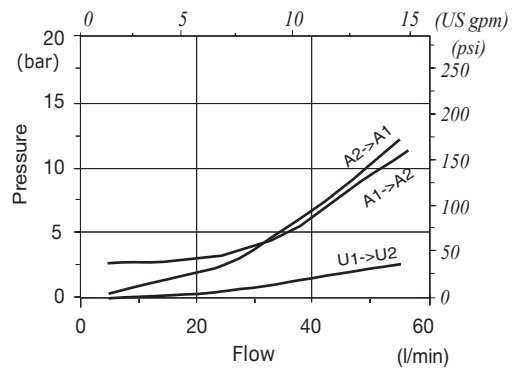

VBPSL 12 pressure drop vs. flow

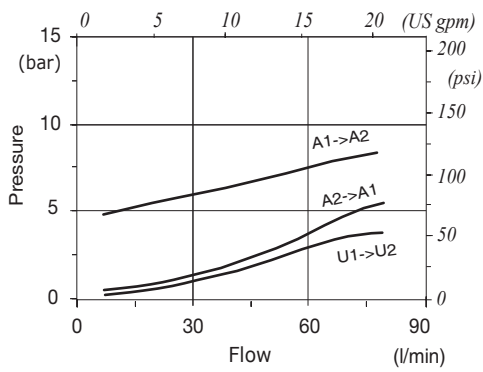

VBPSL 34 pressure drop vs. flow

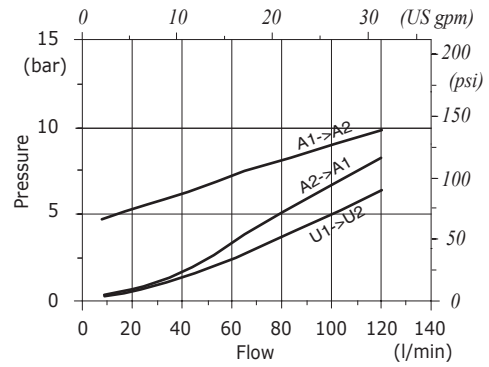



Type VRSE..A pilot operated check valves

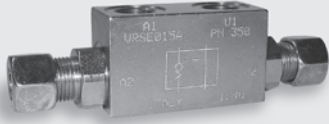

- Single acting
- DIN 2353

Technical specifications and diagrams are measured with mineral oil of 46 cSt viscosity at 40°C (104°F) temperature.

	VRSE01A	VRSE015A	VRSE02A	VRSE025A	VRSE03A	
Nominal flow	30 l/min (7.9 US gpm)		50 l/min (13.2 US gpm)		80 l/min (21.1 US gpm)	
Max. pressure	350 bar (5100 psi)		300 bar (4350 psi)		300 bar (4350 psi)	
Oil leakage	0.25 cm ³ /min (0.015 in ³ /min) at 210 bar (3050 psi)					
Fluid	mineral based oil					
Viscosity	from 10 to 200 cSt					
Max. level of contamination	18/16/13 ISO4406					
Fluid temperature	with NBR seals: from -20°C (-4°F) to 80°C (176°F)					
Environmental temp. for working conditions	from -40°C (-40°F) to 100°C (212°F)					
Weight	steel	0.67 kg (1.48 lb)	0.66 kg (1.45 lb)	0.97 kg (2.14 lb)	0.91 kg (2.01 lb)	1.67 kg (3.68 lb)

NOTE - For different conditions, please contact Walvoil Sales Dpt.

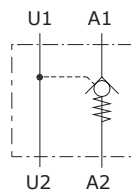

Dimensions

Valve type	All ports
VRSE01A	G1/4
VRSE015A	G3/8
VRSE02A	G3/8
VRSE025A	G1/2
VRSE03A	G1/2

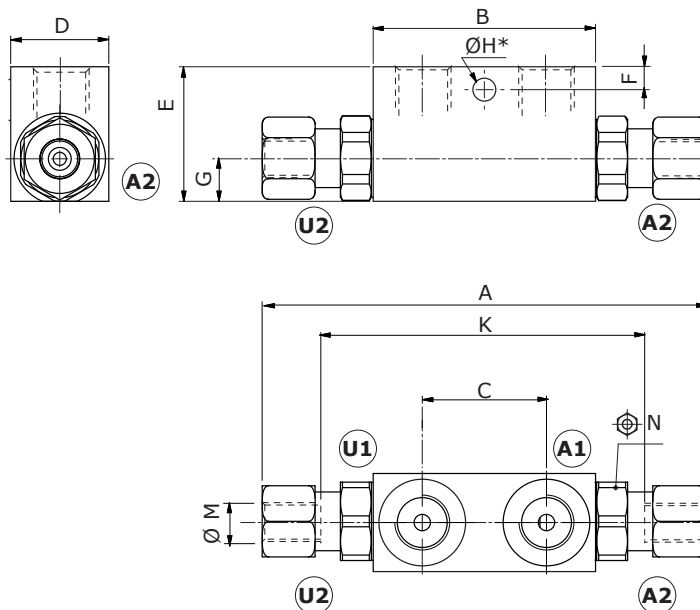

* On request, please contact Walvoil Sales Dpt.

Dimensions are in mm-in

Valve type	A	B max.	C	D	E	F	G	H*	⌀I	⌀L	Ø M	K
VRSE01A	138-5.43	68-2.68	38-1.50	30-1.18	40-1.57	7-0.27	13-0.51	7-0.27	24	22	12-0.47	86-3.38
VRSE015A	138-5.43	68-2.68	38-1.50	30-1.18	40-1.57	7-0.27	13-0.51	7-0.27	24	22	12-0.47	86-3.38
VRSE02A	166-6.53	80-3.15	40-1.57	30-1.18	50-1.97	8.5-0.33	16-0.63	8.5-0.33	27	27	15-0.59	108-4.25
VRSE025A	166-6.53	80-3.15	40-1.57	30-1.18	50-1.97	8.5-0.33	16-0.63	8.5-0.33	27	27	15-0.59	108-4.25
VRSE03A	180-7.09	90-3.54	40-1.57	40-1.57	60-2.36	8.5-0.33	20-0.79	8.5-0.33	30	32	18-0.71	133-5.24

NOTE -* On request, please contact Walvoil Sales Dpt.

Ordering codes and description composition

VRSE 02 A
Port size

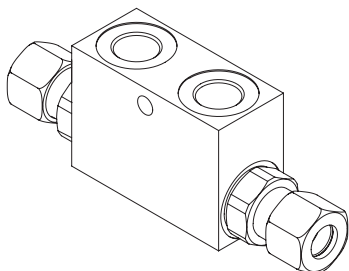

VRSE complete valves

TYPE	CODE	DESCRIPTION
VRSE01A	1410212100	Steel body, G1/4 port, pilot ratio 1:4.5, opening pressure 4 bar (58 psi)
VRSE015A	1410222100	Steel body, G3/8 port, pilot ratio 1:4.5, opening pressure 4 bar (58 psi)
VRSE02A	1410222101	Steel body, G3/8 port, pilot ratio 1:4, opening pressure 4 bar (58 psi)
VRSE025A	1410232100	Steel body, G1/2 port, pilot ratio 1:4, opening pressure 4 bar (58 psi)
VRSE03A	1410232101	Steel body, G1/2 port, pilot ratio 1:4, opening pressure 4 bar (58 psi)

For different configurations or SAE thread please contact our Sales Dpt.

VRSE01A pressure drop vs. flow

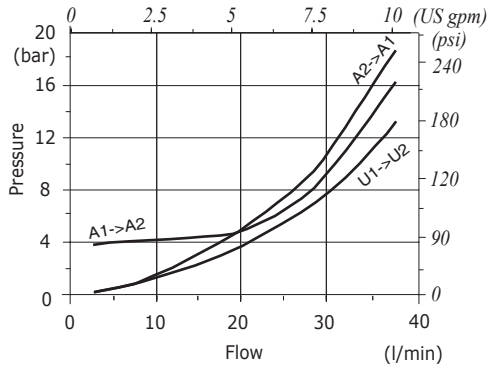

VRSE02A pressure drop vs. flow

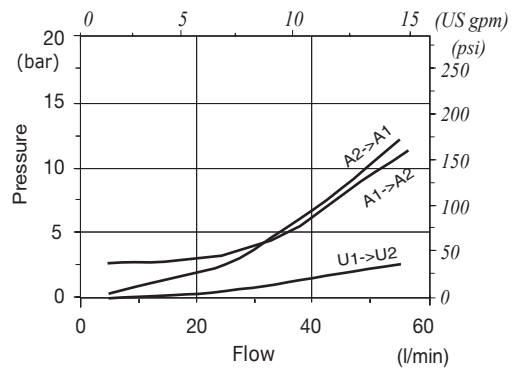

VRSE03A pressure drop vs. flow

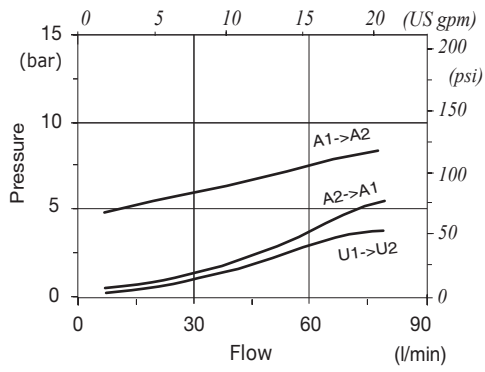



Type VRSE..CIL pilot operated check valves

- Single acting
- Bolt connection

Technical specifications and diagrams are measured with mineral oil of 46 cSt viscosity at 40°C (104°F) temperature.

	VRSE01CIL	VRSE02CIL
Nominal flow	20 l/min (5.3 US gpm)	
Max. pressure	300 bar (4350 psi)	
Oil leakage	0.25 cm ³ /min (0.015 in ³ /min) at 210 bar (3050 psi)	
Fluid	mineral based oil	
Viscosity	from 10 to 200 cSt	
Max. level of contamination	18/16/13 ISO4406	
Fluid temperature	with NBR seals: from -20°C (-4°F) to 80°C (176°F)	
Environmental temperature for working conditions	from -40°C (-40°F) to 100°C (212°F)	
Weight	steel 0.45 kg (0.99 lb)	0.65 kg (1.43 lb)

NOTE - For different conditions, please contact Walvoil Sales Dpt.

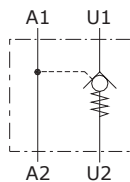

Dimensions

VRSE CIL valve

Valve type	All ports
VRSE01CIL	G1/4
VRSE01CIL	G3/8

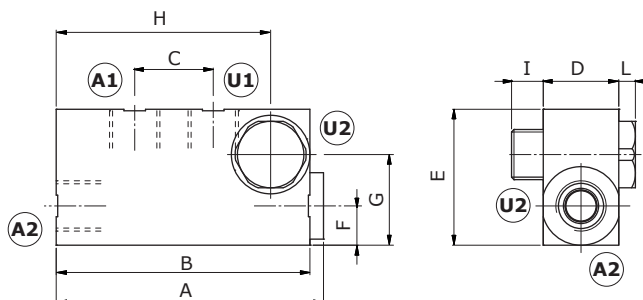
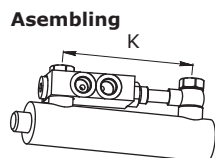

Dimensions are in mm-in

Valve type	A	B	C	D	E	F	G	H	I	L	K min
VRSE01CIL	88.5-3.48	84-3.31	24-0.94	20-0.79	40-1.57	10-0.39	27-1.06	68.5-2.7	10-0.39	6-0.23	123-4.84
VRSE01CIL	90.5-3.56	86-3.38	29-1.14	25-0.98	45-1.77	12-0.47	31-1.22	72-2.83	11-0.43	7-0.27	127-5

Ordering codes and description composition

VRSE 02 CIL

Port size

- without mounting hole
FF with mounting hole

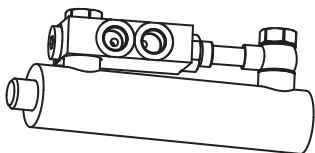

Complete valves

TYPE	CODE	DESCRIPTION
VRSE01CIL	1410312100	Steel body, G1/4 port configuration, opening pressure 1 bar (14.5 psi), pilot ratio 1:4.9
VRSE02CIL	1410322100	Steel body, G3/8 port configuration, opening pressure 1 bar (14.5 psi), pilot ratio 1:4.9

For different configurations or SAE thread please contact our Sales Dept.

Rating diagram

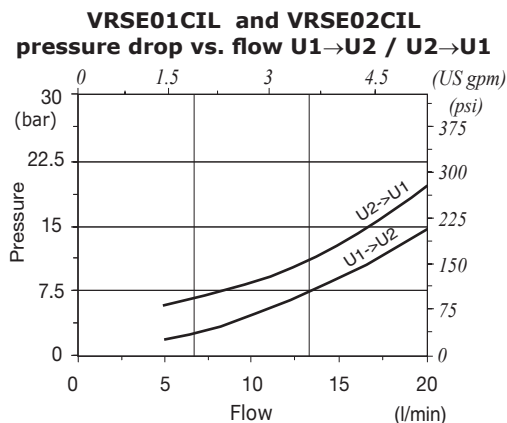
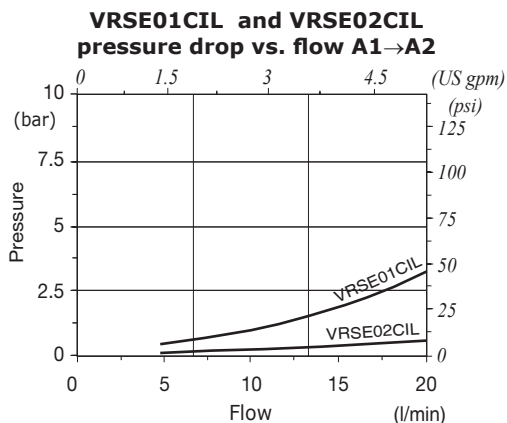



Type VBPSL/T pilot operated check valves

- Single acting

Technical specifications and diagrams are measured with mineral oil of 46 cSt viscosity at 40°C (104°F) temperature.

	VBPSL/T 38	VBPSL/T 12	VBPSL/T 34	
Nominal flow	25 l/min (6.6 US gpm)	50 l/min (13.2 US gpm)	100 l/min (26.4 US gpm)	
Max. pressure	Aluminium body = 210 bar (3050 psi) Steel body = 350 bar (5100 psi)			
Oil leakage	0.25 cm ³ /min (0.015 in ³ /min) at 210 bar (3050 psi)			
Fluid	mineral based oil			
Viscosity	from 10 to 200 cSt			
Max. level of contamination	18/16/13 ISO4406			
Fluid temperature	with NBR seals: from -20°C (-4°F) to 80°C (176°F)			
Environmental temp. for working conditions	from -40°C (-40°F) to 100°C (212°F)			
Weight	aluminium	0.48 kg (1.06 lb)	0.75 kg (1.65 lb)	1.79 kg (3.95 lb)
	steel	1.16 kg (2.56 lb)	1.63 kg (3.59 lb)	4.19 kg (9.24 lb)

NOTE - For different conditions, please contact Walvoil Sales Dpt.

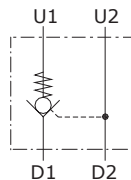

Dimensions

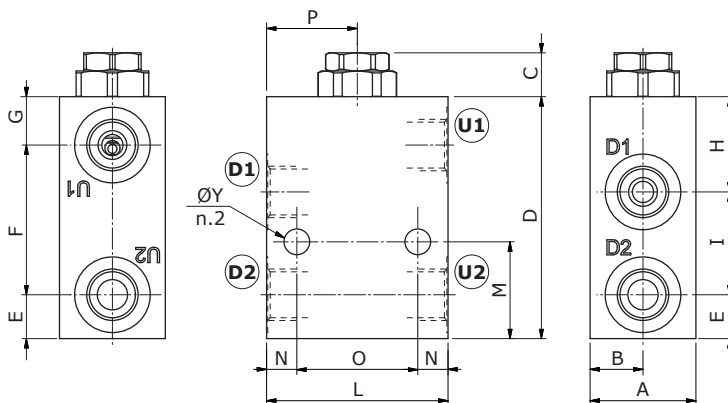

Valve type	All ports
VBPSL/T 38	G3/8
VBPSL/T 12	G1/2
VBPSL/T 34	G3/4
Valve type	All ports
VBPSL/T 12/SAE	SAE10
VBPSL/T 34/SAE	SAE12

Dimensions are in mm-in

Valve type	A	B	C	D	E	F	G	H	I	L	M	N	O	P	ØY
VBPSL/T 38	35 1.38	17.5 0.69	14.5 0.57	80 3.15	14.5 0.57	49.5 1.95	16 0.63	31.5 1.24	34 1.34	60 2.36	32 1.26	10 0.39	40 1.57	20 0.79	8.5 0.33
VBPSL/T 12 VBPSL/T 12/SAE	35 1.38	17.5 0.69	13 0.51	90 3.54	18 0.71	51 2.01	21 0.83	38 1.50	34 1.34	70 2.75	35 1.38	15 0.59	40 1.57	20 0.79	8.5 0.33
VBPSL/T 34 VBPSL/T 34/SAE	50 1.97	25 0.98	16.5 0.65	135 5.31	22 0.87	83 3.27	30 1.18	57.5 2.26	55.5 2.18	90 3.54	55 2.16	20 0.79	50 1.97	25 0.98	10.5 0.41

Ordering codes and description composition

Port size — Pilot ratio
VBPSL/T 38/p4

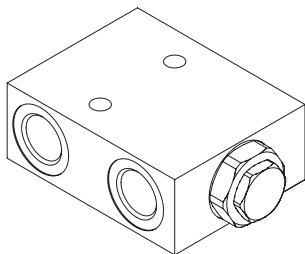

VBPSL/T complete valves

TYPE	CODE	DESCRIPTION
VBPSL/T 38/p4	1412021100	Aluminium body, pilot ratio 1:4, G3/8 ports
VBPSL/T 38/p4/ac	1412022100	Steel body, as previous one
VBPSL/T 12/p4	1412031100	Aluminium body, pilotratio 1:4 G1/2 ports
VBPSL/T 12/p4/ac	1412032100	Steel body, as previous one
VBPSL/T 34/p4	1412041100	Aluminium body, pilot ratio 1:4 G3/4 ports
VBPSL/T 34/p4/ac	1412042101	Steel body, as previous one
VBPSL/T 12/p4/SAE	1412031200	Aluminium body, pilot ratio 1:4 SAE10 ports
VBPSL/T 34/p4/SAE	1412042200	Aluminium body, pilot ratio 1:4 SAE12 ports

For other steel body configurations, other port sizes, SAE thread and configurations with FPM (Viton) seals, please contact our Sales Dpt.

Rating diagram

VBPSL/T 38 pressure drop vs. flow

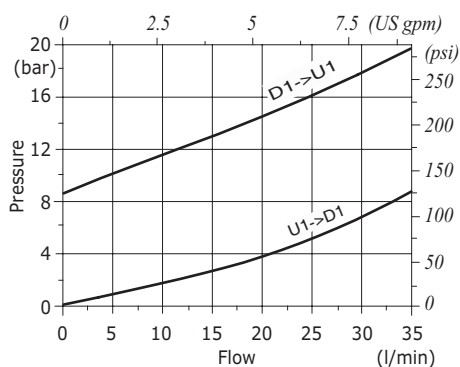

VBPSL/T 12 pressure drop vs. flow

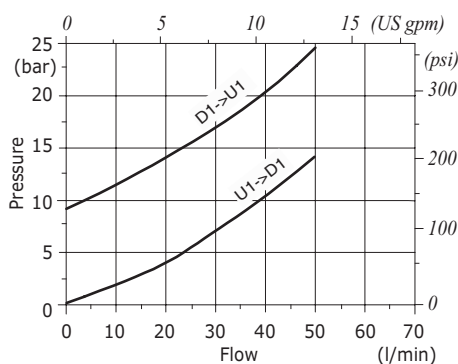

VBPSL/T 34 pressure drop vs. flow

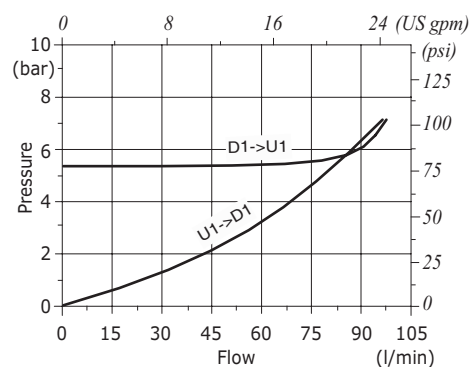



Type VBPSL/SO pilot operated check valves

- Single acting
- With bolt connection

Technical specifications and diagrams are measured with mineral oil of 46 cSt viscosity at 40°C (104°F) temperature.

	VBPSL 14/SO	VBPSL VP38/SO	VBPSL 38/VG/SO	VBPSL 12/SO	
Nominal flow	15 l/min (4.0 US gpm)	25 l/min (6.6 US gpm)	35 l/min (9.2 US gpm)	50 l/min (13.2 US gpm)	
Max. pressure	210 bar (3050 psi)				
Oil leakage	0.25 cm ³ /min (0.015 in ³ /min) at 210 bar (3050 psi)				
Fluid	mineral based oil				
Viscosity	from 10 to 200 cSt				
Max. level of contamination	18/16/13 ISO4406				
Fluid temperature	with NBR seals: from -20°C (-4°F) to 80°C (176°F)				
Environmental temp. for working conditions	from -40°C (-40°F) to 100°C (212°F)				
Weight	aluminium	0.35 kg (0.77 lb)	0.37 kg (0.81 lb)	0.65 kg (1.43 lb)	0.65 kg (1.43 lb)

NOTE - For different conditions, please contact Walvoil Sales Dpt.

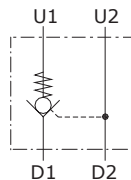

Dimensions

VBPSL 14/SO and VBPSL VP38/SO valves

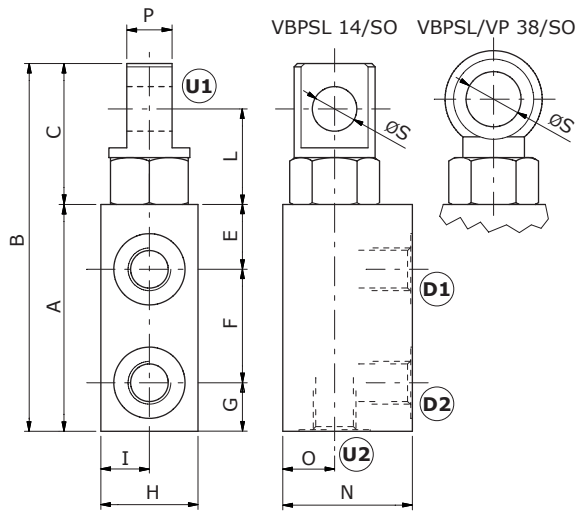

VBPSL 38/VG/SO and VBPSL 12/SO valves

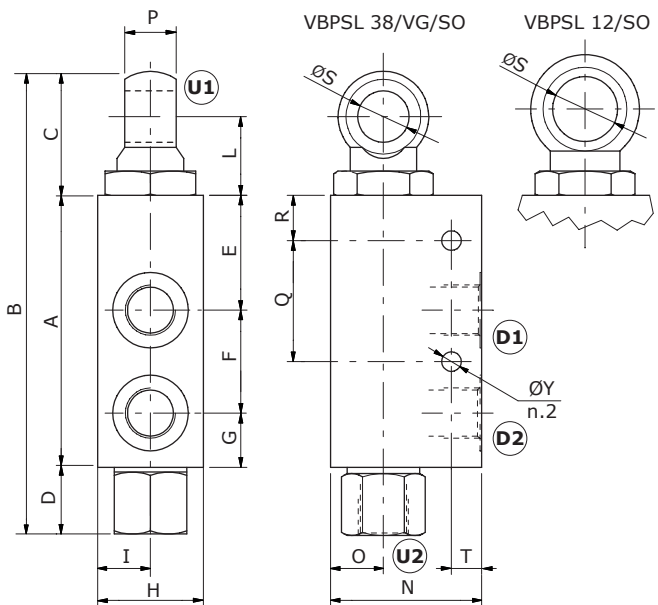

Valve type	All ports
VBPSL 14/SO	G1/4
VBPSL VP38/SO	G3/8
VBPSL 38/VG/SO	G3/8
VBPSL 12/SO	G1/2

Dimensions are in mm-in

Valve type	A	B	C	D	E	F	G	H	I	L	N	O	P	Q	R	ØS	T	ØY
VBPSL 14/SO	70 2.75	113.5 4.47	43.5 1.71	/	20 0.79	35 1.38	15 0.59	30 1.18	15 0.59	29.5 1.16	40 1.57	16 0.63	14 0.55	/	/	13.75 0.541	/	/
VBPSL VP38/SO	80 3.15	127 5.02	47.5 1.87	/	22.5 0.88	35 1.38	22.5 0.88	30 1.18	15 0.59	32.5 1.28	40 1.57	16 0.63	17 0.67	/	/	17 0.67	/	/
VBPSL 38/VG/SO	90 0.35	153 6.02	41 1.61	21.5 0.85	38 1.50	34 1.34	18 0.71	35 1.38	17.5 0.69	26 1.02	50 1.97	17.5 0.69	17 0.67	40 1.57	15 0.59	17 0.67	10 0.39	6.5 0.256
VBPSL 12/SO	90 0.35	161.5 6.36	47.5 1.87	24.5 0.96	38 1.50	34 1.34	18 0.71	35 1.38	17.5 0.69	28.5 1.12	50 1.97	17.5 0.69	23.5 0.93	40 1.57	15 0.59	21.2 0.83	10 0.39	6.5 0.256

Ordering codes and description composition

Port size
VBPSL 14/SO/p4
Pilot ratio

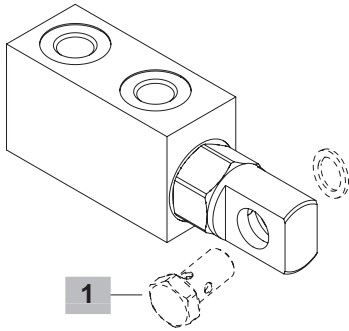

VBPSL/SO complete valves

TYPE	CODE	DESCRIPTION
VBPSL 14/SO/p4	1411011100	Aluminium body, pilot ratio 1:4 G1/4 ports
VBPSL VP38/SO/p4	1411011150	Aluminium body, pilot ratio 1:4 G3/8 ports
VBPSL 38/VG/SO/p4	1411021100	Aluminium body, pilot ratio 1:4 G3/8 ports
VBPSL 12/SO/p4	1411031100	Aluminium body, pilot ratio 1:4 G1/2 ports

For other steel body configurations, SAE threads and configurations with FPM (Viton) seals, please contact our Sales Dpt.

1 Optional joint kit with washer

CODE	DESCRIPTION
4XBR1110240	G 1/4 male thread
4XBR1120310	G 3/8 male thread
4XBR1130380	G 1/2 male thread

Ordering codes and description composition

VBPSL 14/SO pressure drop vs. flow

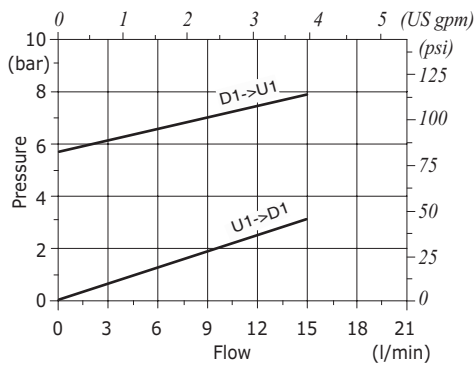

VBPSL/VP 38/SO pressure drop vs. flow

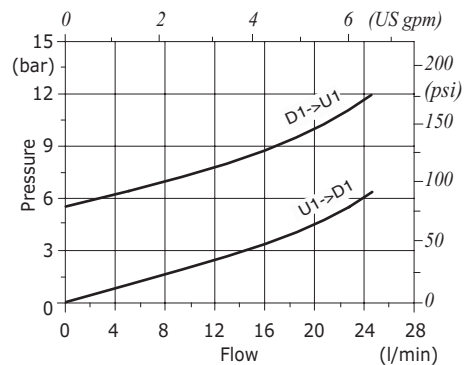

VBPSL 38/VG/SO pressure drop vs. flow

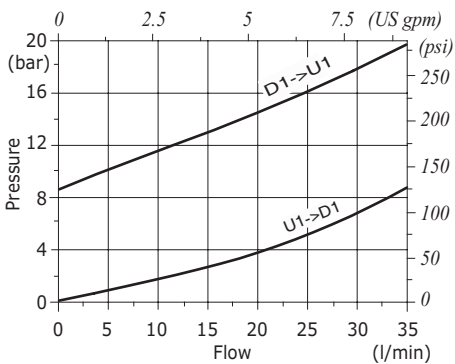

VBPSL 12/SO pressure drop vs. flow

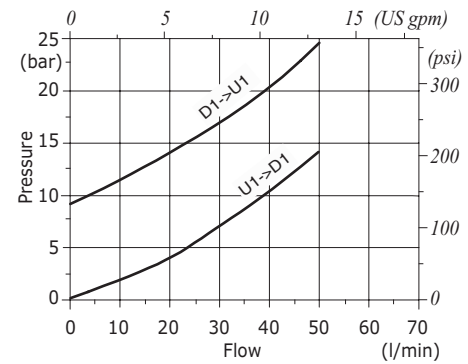



Type VBPSF pilot operated check valves

- Single acting
- Face mounting

Technical specifications and diagrams are measured with mineral oil of 46 cSt viscosity at 40°C (104°F) temperature.

	VBPSF 14	VBPSF 38	VBPSF 12	VBPSF 34	
Nominal flow	15 l/min (4.0 US gpm)	35 l/min (9.2 US gpm)	50 l/min (13.2 US gpm)	100 l/min (26.4 US gpm)	
Max. pressure	Aluminium body = 210 bar (3050 psi) Steel body = 350 bar (5100 psi)				
Oil leakage	0.25 cm ³ /min (0.015 in ³ /min) at 210 bar (3050 psi)				
Fluid	mineral based oil				
Viscosity	from 10 to 200 cSt				
Max. level of contamination	18/16/13 ISO4406				
Fluid temperature	with NBR seals: from -20°C (-4°F) to 80°C (176°F)				
Environmental temp. for working conditions	from -40°C (-40°F) to 100°C (212°F)				
Weight	aluminium	0.34 kg (0.75 lb)	0.81 kg (1.79 lb)	0.73 kg (1.61 lb)	1.67 kg (3.68 lb)
	steel		1.71 kg (3.77 lb)	1.65 kg (3.63 lb)	3.84 kg (8.47 lb)

NOTE - For different conditions, please contact Walvoil Sales Dpt.

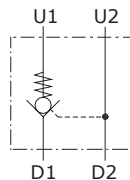

Dimension

Valve type	All ports
VBPSF 14	G1/4
VBPSF 38	G3/8
VBPSF 12	G1/2
VBPSF 34	G3/4

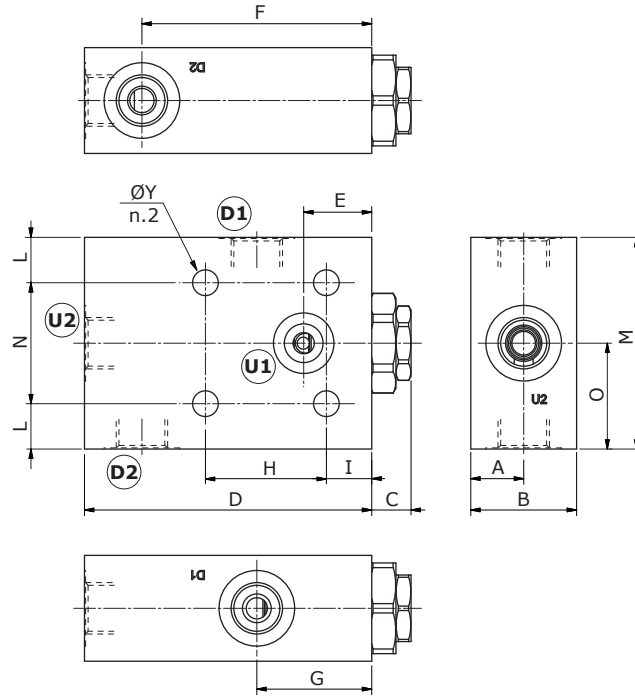

Dimensions are in mm-in

Valve type	A	B	C	D	E	F	G	H	I	L	M	N	O	ØY
VBPSF 14	15 0.59	30 1.18	14.5 0.57	70 2.75	17.5 0.69	67 2.64	30 1.18	35 1.38	8.5 0.33	7.5 0.29	50 1.97	35 1.38	25 0.98	6.5 0.25
VBPSF 38	17.5 0.69	35 1.38	13 0.51	95 3.74	22.5 0.88	76 2.99	38 1.50	40 1.57	15 0.59	15 0.59	70 2.75	40 1.57	35 1.38	8.5 0.33
VBPSF 12	17.5 0.69	35 1.38	13 0.51	95 3.74	22.5 0.88	76 2.99	38 1.50	40 1.57	15 0.59	15 0.59	70 2.75	40 1.57	35 1.38	8.5 0.33
VBPSF 34	24.5 0.96	49 1.93	16.5 0.65	130 5.12	30 1.18	107.5 4.23	58 2.28	67.5 2.66	15 0.59	19.5 0.77	89 3.51	50 1.97	44.5 1.75	10.5 0.41

Ordering codes and description composition

Port size
VBPSF 14/p4
Pilot ratio

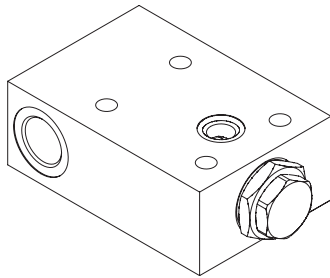

VBPSF complete valves

TYPE	CODE	DESCRIPTION
VBPSF 14/p4	1416011100	Aluminium body, pilot ratio 1:4, G1/4 ports
VBPSF 38/p4	1416021100	Aluminium body, pilot ratio 1:4, G3/8 ports
VBPSF 38/p4/ac	1416022100	Steel body, as previous one
VBPSF 12/p4	1416031100	Aluminium body, pilot ratio 1:4, G1/2 ports
VBPSF 12/p4/ac	1416032100	Steel body, as previous one
VBPSF 34/p4	1416041100	Aluminium body, pilot ratio 1:4, G3/4 ports
VBPSF 34/p4/ac	1416042100	Steel body, as previous one

For other steel body configurations, SAE thread and configurations with FPM (Viton) seals, please contact our Sales Dpt.

Rating diagrams

VBPSF 14 pressure drop vs. flow

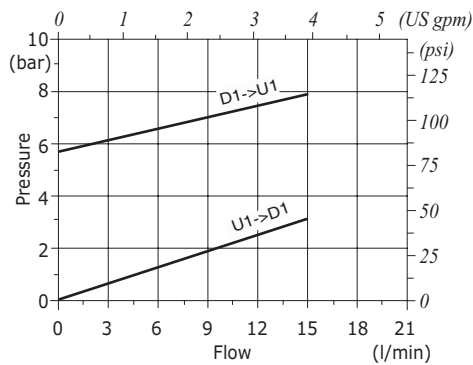

VBPSF 12 pressure drop vs. flow

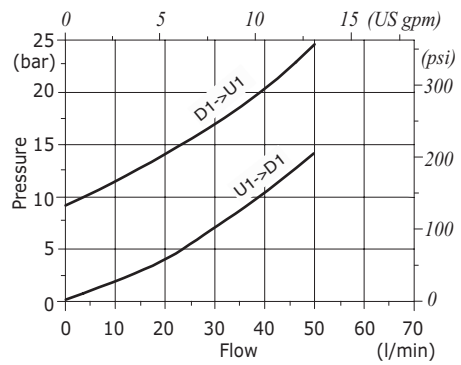

VBPSF 38 pressure drop vs. flow

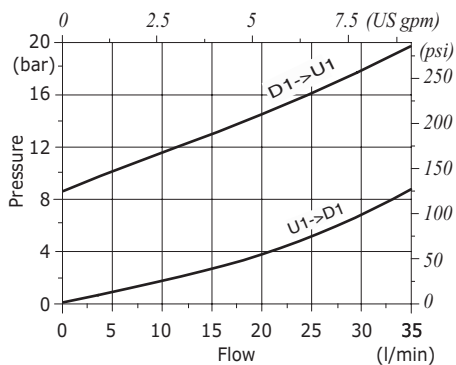

VBPSF 34 pressure drop vs. flow

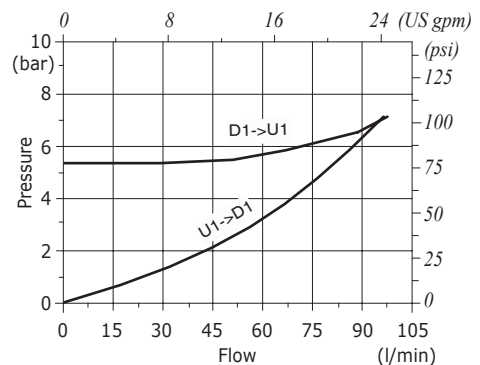

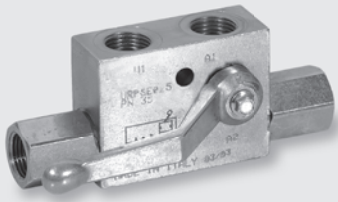

Type VBPSL/R pilot operated check valves

- Single acting
- Shut-off

Technical specifications and diagrams are measured with mineral oil of 46 cSt viscosity at 40°C (104°F) temperature.

	VBPSL/R..14	VBPSL/VP/R..38	VBPSL/R..38	VBPSL/VP/R..12	
Nominal flow	25 l/min (6.6 US gpm)		50 l/min (13.2 US gpm)		
Max. pressure	350 bar (5100 psi)		300 bar (4350 psi)		
Oil leakage	0.25 cm ³ /min (0.015 in ³ /min) at 210 bar (3050 psi)				
Fluid	mineral based oil				
Viscosity	from 10 to 200 cSt				
Max. level of contamination	18/16/13 ISO4406				
Fluid temperature	with NBR seals: from -20°C (-4°F) to 80°C (176°F)				
Environmental temp. for working conditions	from -40°C (-40°F) to 100°C (212°F)				
Weight	steel	0.95 kg (2.09 lb)	0.95 kg (2.09 lb)	1.12 kg (2.47 lb)	1.12 kg (2.47 lb)

NOTE - For different conditions, please contact Walvoil Sales Dpt.

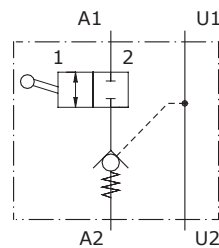

Dimension

Valve type	All ports
VBPSL/R..14	G1/4
VBPSL/VP/R..38	G3/8
VBPSL/R..38	G3/8
VBPSL/VP/R..12	G1/2

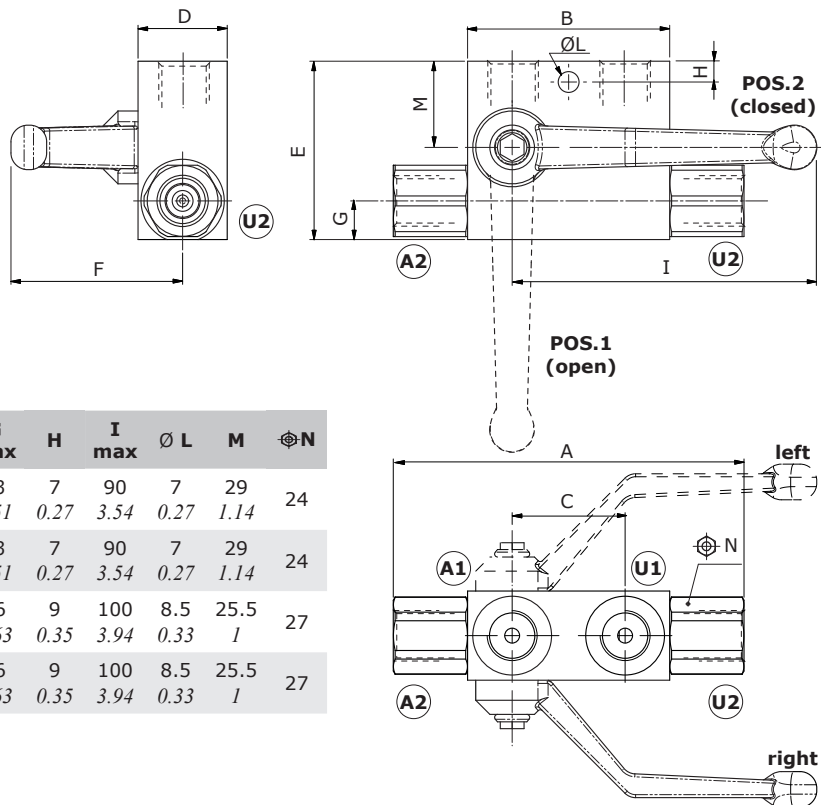

Dimensions are in mm-in

Valve type	A	B	C	D	E	F max	G max	H	I max	Ø L	M	⊕N
VBPSL/R..14	118 4.64	68 2.68	38 1.50	30 1.18	60 2.36	65 2.56	13 0.51	7 0.27	90 3.54	7 0.27	29 1.14	24
VBPSL/VP/R..38	118 4.64	68 2.68	38 1.50	30 1.18	60 2.36	65 2.56	13 0.51	7 0.27	90 3.54	7 0.27	29 1.14	24
VBPSL/R..38	143 5.63	80 3.15	40 1.57	30 1.18	60 2.36	60 2.36	16 0.63	9 0.35	100 3.94	8.5 0.33	25.5 1	27
VBPSL/VP/R..12	143 5.63	80 3.15	40 1.57	30 1.18	60 2.36	60 2.36	16 0.63	9 0.35	100 3.94	8.5 0.33	25.5 1	27

Ordering codes and description composition

D - right
S - left
Port size

VBPSL/R D 14

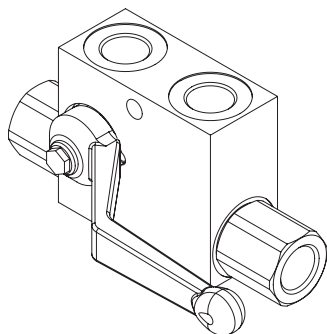

VBPSLR complete valves

TYPE	CODE	DESCRIPTION
VBPSL/R/S 14/p4,5/Pa4/ac	1415312100	Steel body, opening pressure 4 bar (58 psi), pilot ratio 1:4.5, G1/4 ports, left lever
VBPSL/R/D 14/p4,5/Pa4/ac	1415312101	As previous with right lever
VBPSL/R/S 38/p4/Pa4/ac	1415322100	Steel body, opening pressure 4 bar (58 psi), pilot ratio 1:4, G3/8 ports, left lever
VBPSL/R/D 38/p4/Pa4/ac	1415322101	As previous with right lever
VBPSL/VP/R/S 38/p4,5/Pa4/ac	1415322102	Steel body, opening pressure 4 bar (58 psi), pilot ratio 1:4.5, G3/8 ports, left lever
VBPSL/VP/R/D 38/p4,5/Pa4/ac	1415322103	As previous with right lever
VBPSL/VP/R/S 12/p4/Pa4/ac	1415332100	Steel body, opening pressure 4 bar (58 psi), pilot ratio 1:4, G1/2 ports, left lever
VBPSL/VP/R/D 12/p4/Pa4/ac	1415332101	As previous with right lever

For different configurations or SAE threads please contact our Sales Dpt.

Rating diagram

VBPSL/R..14 pressure drop vs. flow

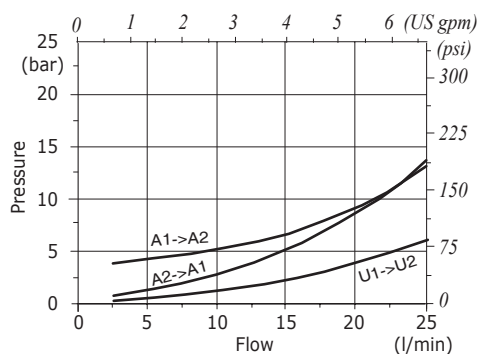

VBPSL/R..38 pressure drop vs. flow

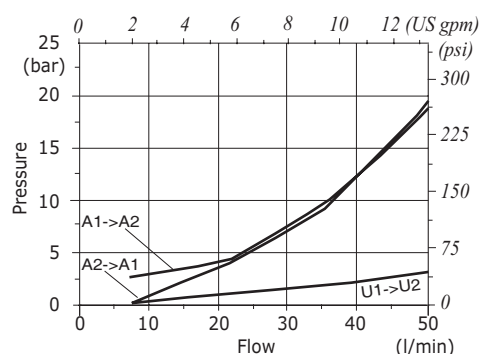



Type VRPSE..A.. pilot operated check valves

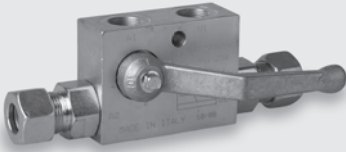

- Single acting
- Shut-off
- DIN 2353

Technical specifications and diagrams are measured with mineral oil of 46 cSt viscosity at 40°C (104°F) temperature.

	VRPSE01A..	VRPSE015A..	VRPSE02A..	VRPSE025A..	
Nominal flow	25 l/min (6.6 US gpm)		50 l/min (13.2 US gpm)		
Max. pressure	350 bar (5100 psi)		300 bar (4350 psi)		
Oil leakage	0.25 cm ³ /min (0.015 in ³ /min) at 210 bar (3050 psi)				
Fluid	mineral based oil				
Viscosity	from 10 to 200 cSt				
Max. level of contamination	18/16/13 ISO4406				
Fluid temperature	with NBR seals: from -20°C (-4°F) to 80°C (176°F)				
Environmental temp. for working conditions	from -40°C (-40°F) to 100°C (212°F)				
Weight	steel	0.95 kg (2.09 lb)	0.95 kg (2.09 lb)	1.12 kg (2.47 lb)	1.12 kg (2.47 lb)

NOTE - For different conditions, please contact Walvoil Sales Dpt.

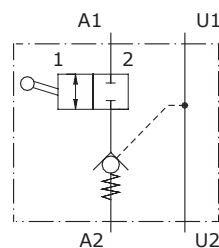

Dimension

Valve type	A1-U1	A2-U2
VRPSE01A..	G1/4	12 0.27
VRPSE015A..	G3/8	12 0.27
VRPSE02A..	G3/8	15 0.59
VRPSE025A..	G1/2	15 0.59

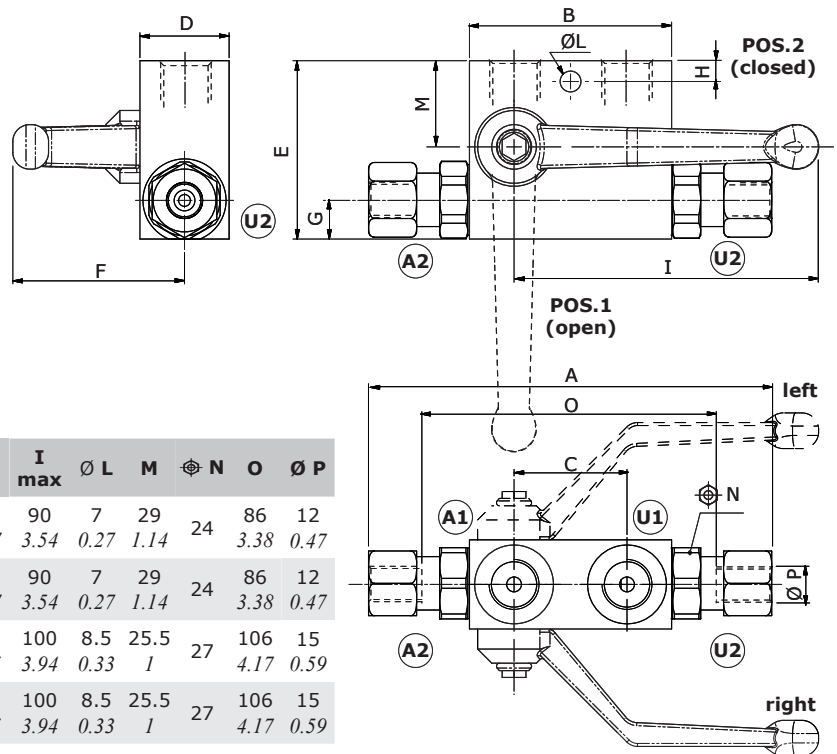

Dimensions are in mm-in

Valve type	A	B	C	D	E	F max	G max	H	I max	Ø L	M	Ø N	O	Ø P
VRPSE01A..	138 5.43	68 2.68	38 1.50	30 1.18	60 2.36	65 2.56	13 0.51	7 0.27	90 3.54	7 0.27	29 1.14	24	86 3.38	12 0.47
VRPSE015A..	138 5.43	68 2.68	38 1.50	30 1.18	60 2.36	65 2.56	13 0.51	7 0.27	90 3.54	7 0.27	29 1.14	24	86 3.38	12 0.47
VRPSE02A..	140 5.51	80 3.15	40 1.57	30 1.18	60 2.36	60 2.36	16 0.63	9 0.35	100 3.94	8.5 0.33	25.5 1	27	106 4.17	15 0.59
VRPSE025A..	140 5.51	80 3.15	40 1.57	30 1.18	60 2.36	60 2.36	16 0.63	9 0.35	100 3.94	8.5 0.33	25.5 1	27	106 4.17	15 0.59

Ordering codes and description composition

Port size R - right
L - left

VRPSE 01 A R

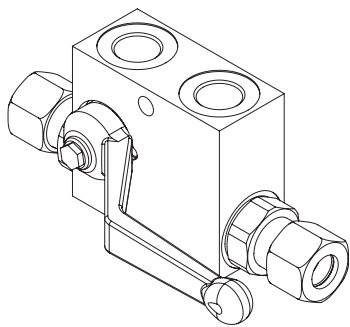

VRPSE complete valves

TYPE	CODE	DESCRIPTION
VRPSE01AL	1415412100	Steel body, opening pressure 4 bar (58 psi), pilot ratio 1:4.5, G1/4 ports, left lever
VRPSE01AR	1415412101	Steel body, opening pressure 4 bar (58 psi), pilot ratio 1:4.5, G1/4 ports, right lever
VRPSE02AL	1415422100	Steel body, opening pressure 4 bar (58 psi), pilot ratio 1:4, G3/8 ports, left lever
VRPSE02AR	1415422101	Steel body, opening pressure 4 bar (58 psi), pilot ratio 1:4, G3/8 ports, right lever
VRPSE015AL	1415422102	Steel body, opening pressure 4 bar (58 psi), pilot ratio 1:4.5, G3/8 ports, left lever
VRPSE015AR	1415422103	Steel body, opening pressure 4 bar (58 psi), pilot ratio 1:4.5, G3/8 ports, right lever
VRPSE025AL	1415432100	Steel body, opening pressure 4 bar (58 psi), pilot ratio 1:4, G1/2 ports, left lever
VRPSE025AR	1415432101	Steel body, opening pressure 4 bar (58 psi), pilot ratio 1:4, G1/2 ports, right lever

For different configurations or SAE thread please contact our Sales Dpt.

Rating diagram

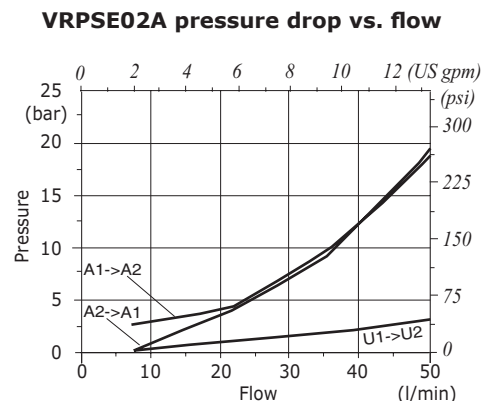
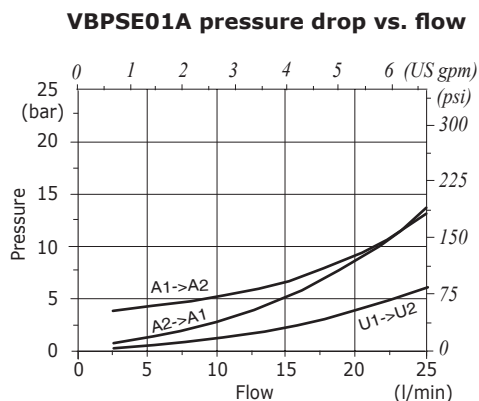

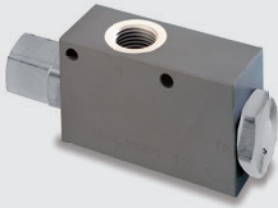

Type VBPSL/PS pilot operated check valves

- External pilot operated type

Technical specifications and diagrams are measured with mineral oil of 46 cSt viscosity at 40°C (104°F) temperature.

	VBPSL/PS 38	VBPSL/PS 12
Nominal flow	25 l/min (6.6 US gpm)	35 l/min (9.2 US gpm)
Max. pressure	Aluminium body = 210 bar (3050 psi) Steel body = 350 bar (5100 psi)	
Oil leakage	0.25 cm ³ /min (0.015 in ³ /min) at 210 bar (3050 psi)	
Fluid	mineral based oil	
Viscosity	from 10 to 200 cSt	
Max. level of contamination	18/16/13 ISO4406	
Fluid temperature	with NBR seals from -20°C (-4°F) to 80°C (176°F)	
Environmental temperature for working conditions	from -40°C (-40°F) to 100°C (212°F)	
Weight	aluminium	0.53 kg (1.17 lb)
	steel	1.07 kg (2.36 lb)
		0.65 kg (1.43 lb)
		1.22 kg (2.69 lb)

NOTE - For different conditions, please contact Walvoil Sales Dpt.

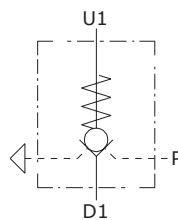

Dimensions

Valve type	U1 - D1	P
VBPSL/PS 38	G3/8	G1/4
VBPSL/PS 12	G1/2	G1/4
Valve type	U1 - D1	P
VBPSL/PS 38/SAE	SAE8	SAE6
VBPSL/PS 12/SAE	SAE10	SAE6

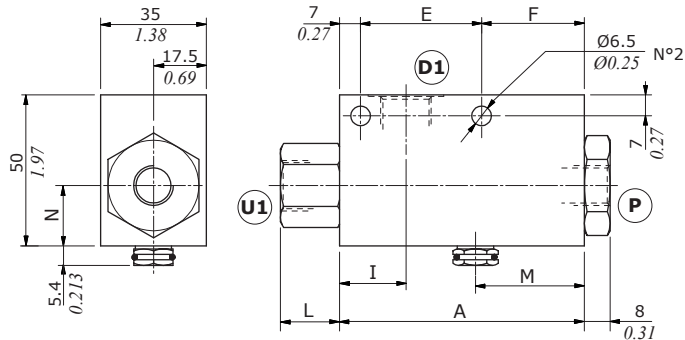

Dimensions are in mm-in

Valve type	A	E	F	I	L	M	N
VBPSL/PS 38 VBPSL/PS 38/SAE	81-3.19	40-1.57	34-1.34	22-0.87	19.5-0.77	36-1.42	20-0.79
VBPSL/PS 12 VBPSL/PS 12/SAE	90-3.54	50-1.97	33-1.30	32-1.26	33-1.30	35-1.38	30-1.18

Ordering codes and description composition

Port size
VBPSL/PS 38/p10
 Pilot ratio

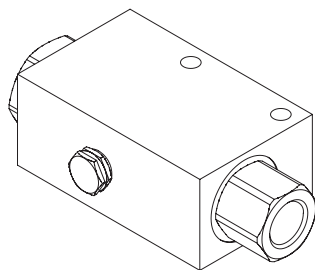

VBPSL/PS complete valves

TYPE	CODE	DESCRIPTION
VBPSL/PS 38/p10	1413021100	Aluminium body, pilot ratio 1:10, G3/8 ports
VBPSL/PS 38/p10/ac	1413022100	Steel body, as previous one
VBPSL/PS 12/p6	1413031100	Aluminium body, pilot ratio 1:6, G1/2 ports
VBPSL/PS 12/p6/ac	1413032100	Steel body, as previous one
VBPSL/PS 38/p10/SAE	1413021200	Aluminium body, pilot ratio 1:10, SAE8 ports
VBPSL/PS 12/p6/SAE	1413031200	Aluminium body, pilot ratio 1:6, SAE10 ports

For other steel body configurations, SAE thread and configurations with FPM (Viton) seals, please contact our Sales Dpt.

Rating diagram

VBPSL/PS 38 pressure drop vs. flow

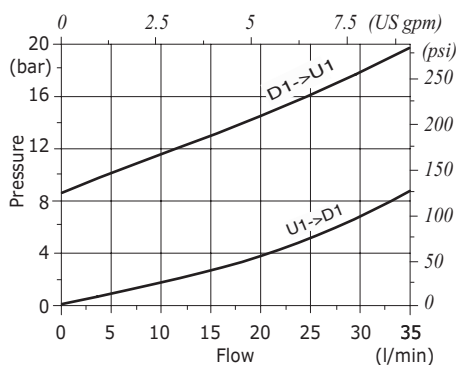

VBPSL/PS 12 pressure drop vs. flow

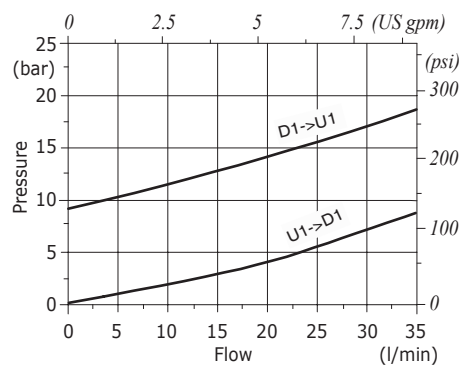

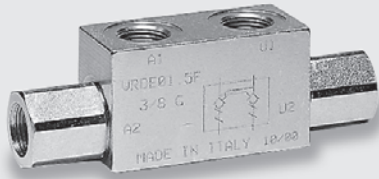

Type VBPDL pilot operated check valves

- Double acting

Technical specifications and diagrams are measured with mineral oil of 46 cSt viscosity at 40°C (104°F) temperature.

	VBPDL 14	VBPDL VP 38	VBPDL 38	VBPDL VP 12	VBPDL 12	VBPDL 34	
Nominal flow	30 l/min (7.9 US gpm)		50 l/min (13.2 US gpm)		80 l/min (21.1 US gpm)	120 l/min (31.7 US gpm)	
Max. pressure	350 bar (5100 psi)		300 bar (4350 psi)		300 bar (4350 psi)	300 bar (4350 psi)	
Oil leakage	0.25 cm ³ /min (0.015 in ³ /min) at 210 bar (3050 psi)						
Fluid	mineral based oil						
Viscosity	10-200 cSt						
Max. level of contamination	18/16/13 ISO4406						
Fluid temperature	with NBR seals from -20°C (-4°F) to 80°C (176°F)						
Environmental temp. for working conditions	from -40°C (-40°F) to 100°C (212°F)						
Weight	Steel	0.68 kg (1.5 lb)	0.63 kg (1.39 lb)	0.97 kg (2.14 lb)	0.9 kg (1.98 lb)	1.69 kg (3.72 lb)	3.06 kg (6.75 lb)

NOTE - For different conditions, please contact Walvoil Sales Dpt.

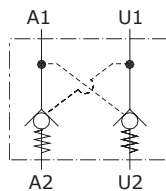

Dimensions

Valve type	All ports
VBPDL 14	G1/4
VBPDL VP 38	G3/8
VBPDL 38	G3/8
VBPDL VP 12	G1/2
VBPDL 12	G1/2
VBPDL 34	G3/4

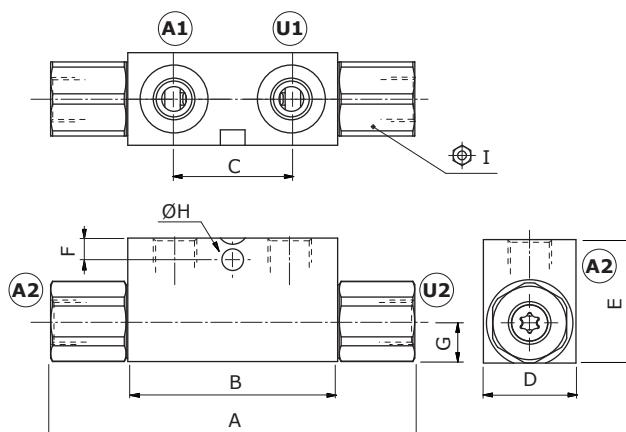

Dimensions are in mm-in

Valve type	A max.	B	C	D	E	F	G	H	I
VBPDL 14	118-4.64	68-2.68	38-1.50	30-1.18	40-1.57	7-0.27	13-0.51	8-0.31	24
VBPDL VP 38	118-4.64	68-2.68	38-1.50	30-1.18	40-1.57	7-0.27	13-0.51	8-0.31	24
VBPDL 38	144-5.67	80-3.15	40-1.57	30-1.18	50-1.97	15-0.59	16-0.63	8.5-0.33	27
VBPDL VP 12	144-5.67	80-3.15	40-1.57	30-1.18	50-1.97	15-0.59	16-0.63	8.5-0.33	27
VBPDL 12	171-6.73	90-3.54	40-1.57	40-1.57	60-2.36	15-0.59	20-0.79	8.5-0.33	30
VBPDL 34	196 ⁽¹⁾ -7.72 ⁽¹⁾	107-4.21	60-2.36	50-1.97	70-2.75	16-0.63	23-0.90	8.5-0.33	41

NOTE - ⁽¹⁾ Only for 04 SAE 208

Ordering codes and description composition

VBPDL 14 / p4,5 / Pa4 / ac
 Port size: 14, Opening pressure: Pa4, Pilot ratio: p4,5

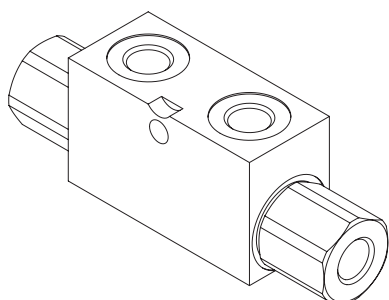

VBPDL Complete valves

TYPE	CODE	DESCRIPTION
VBPDL 14/p4,5/Pa4/ac	1420112100	Steel body, G1/4 port configuration, pilot ratio 1:4.5, opening pressure 4 bar (58 psi)
VBPDL 38/p4/Pa4/ac	1420122100	Steel body, G3/8 port configuration, pilot ratio 1:4, opening pressure 4 bar (58 psi)
VBPDL VP 38/p4/Pa4/ac	1420122101	Steel body, G3/8 port configuration, pilot ratio 1:4.5, opening pressure 4 bar (58 psi)
VBPDL 12/p4/Pa4/ac	1420132100	Steel body, G1/2 port configuration, pilot ratio 1:4, opening pressure 4 bar (58 psi)
VBPDL VP 12/p4/Pa4/ac	1420132101	Steel body, G1/2 port configuration, pilot ratio 1:4, opening pressure 4 bar (58 psi)
VBPDL 34/p4/Pa4/ac	1420142100	Steel body, G3/4 port configuration, pilot ratio 1:4, opening pressure 4 bar (58 psi)

For different configurations or SAE thread please contact our Sales Dpt.

Rating diagrams

VBPDL 14 pressure drop vs. flow

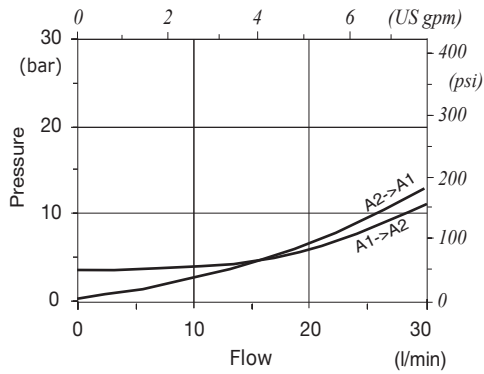

VBPDL 38 pressure drop vs. flow

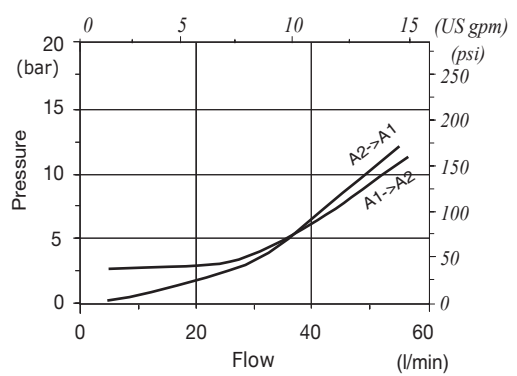

VBPDL 12 pressure drop vs. flow

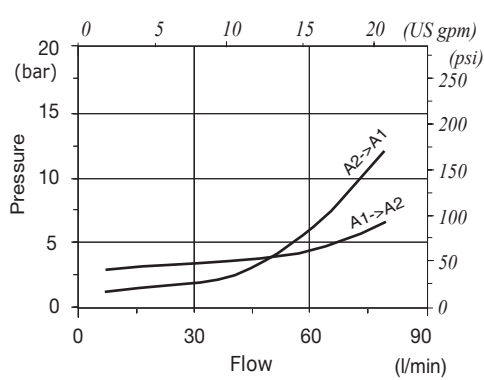

VBPDL 34 pressure drop vs. flow

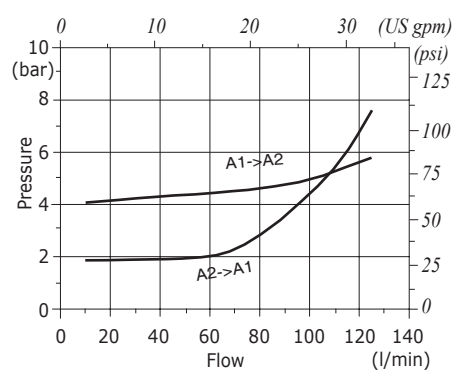



Type VRDE..A pilot operated check valves

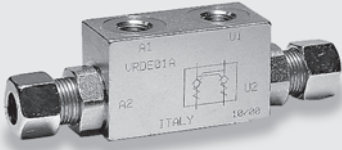

- Double acting
- DIN 2353

Technical specifications and diagrams are measured with mineral oil ISO VG32 at 50°C (122°F) temperature.

	VRDE01A	VRDE015A	VRDE02A	VRDE025A	VRDE03A	
Nominal flow	30 l/min (7.92 US gpm)	30 l/min (7.92 US gpm)	50 l/min (13.2 US gpm)	50 l/min (13.2 US gpm)	80 l/min (21.1 US gpm)	
Max. pressure	350 bar (5100 psi)		300 bar (4350 psi)			
Oil leakage	0.25 cm ³ /min (0.015 in ³ /min) at 210 bar (3050 psi)					
Fluid	mineral based oil					
Viscosity	10-200 cSt					
Max. level of contamination	18/16/13 ISO4406					
Fluid temperature	with NBR seals from -20°C (-4°F) to 80°C (176°F)					
Environmental temp. for working conditions	-40°C (-40°F) to 100°C (212°F)					
Weight	<i>steel</i>	0.67 kg (1.48 lb)	0.66 kg (1.45 lb)	0.97 kg (2.14 lb)	0.91 kg (2.01 lb)	1.67 kg (3.68 lb)

NOTE - For different conditions, please contact Walvoil Sales Dpt.

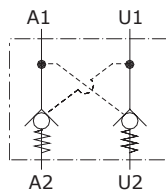

Dimension

Valve type	All ports
VRDE01A	G1/4
VRDE015A	G3/8
VRDE02A	G3/8
VRDE025A	G1/2
VRDE03A	G1/2

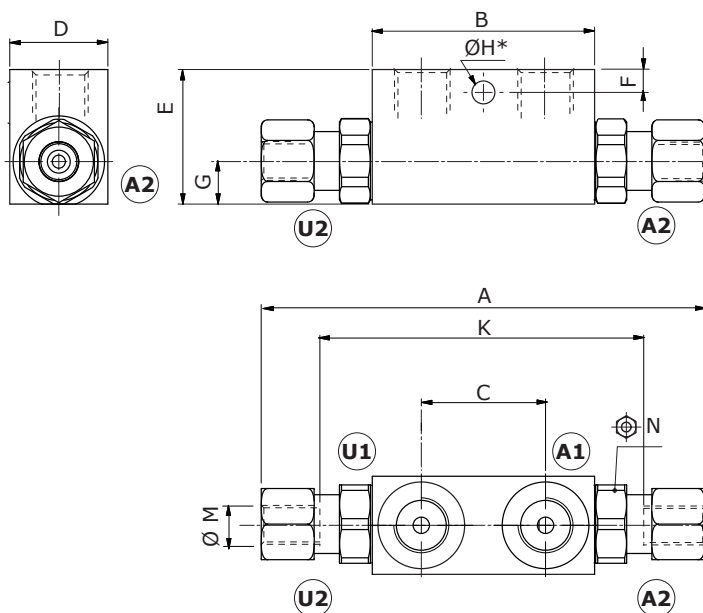

* On request, please contact Walvoil Sales Dpt.

Dimensions are in mm-in

Valve type	A	B max.	C	D	E	F	G	H*	ØI	ØL	ØM	K
VRDE01A	138-5.43	68-2.68	38-1.50	30-1.18	40-1.57	7-0.27	13-0.51	7-0.27	24	22	12-0.47	86-3.38
VRDE 015A	138-5.43	68-2.68	38-1.50	30-1.18	40-1.57	7-0.27	13-0.51	7-0.27	24	22	12-0.47	86-3.38
VRDE02A	166-6.53	80-3.15	40-1.57	30-1.18	50-1.97	15-0.59	16-0.63	8.5-0.33	27	27	15-0.59	108-4.25
VRDE025A	166-6.53	80-3.15	40-1.57	30-1.18	50-1.97	15-0.59	16-0.63	8.5-0.33	27	27	15-0.59	108-4.25
VRDE03A	180-7.09	90-3.54	40-1.57	40-1.57	60-2.36	15-0.59	20-0.79	8.5-0.33	30	32	18-0.71	133-5.24

NOTE - * On request, please contact Walvoil Sales Dpt.

Ordering codes and description composition

Port size
VRDE 02 A

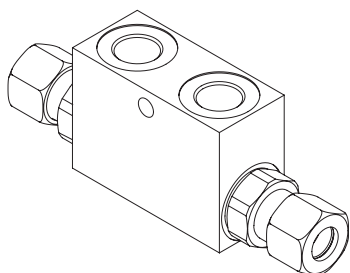

VRDE A complete valves

TYPE	CODE	DESCRIPTION
VRDE01A	1420212100	Steel body, G1/4 port, pilot ratio 1:4.5, opening pressure 4 bar (58 psi)
VRDE015A	1420222100	Steel body, G3/8 port, pilot ratio 1:4.5, opening pressure 4 bar (58 psi)
VRDE02A	1420222101	Steel body, G3/8 port, pilot ratio 1:4, opening pressure 4 bar (58 psi)
VRDE025A	1420232100	Steel body, G1/2 port, pilot ratio 1:4, opening pressure 4 bar (58 psi)
VRDE03A	1420232101	Steel body, G1/2 port, pilot ratio 1:4, opening pressure 4 bar (58 psi)

For different configurations or SAE threads please contact our Sales Dpt.

VRDE01A pressure drop vs. flow

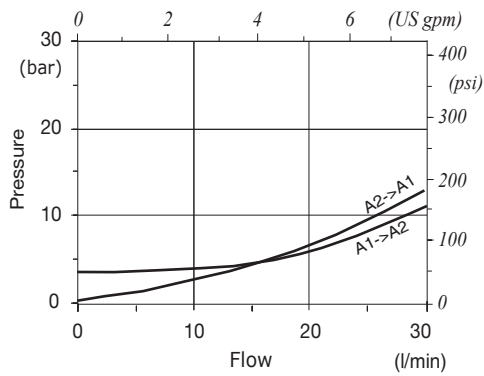

VRDE02A pressure drop vs. flow

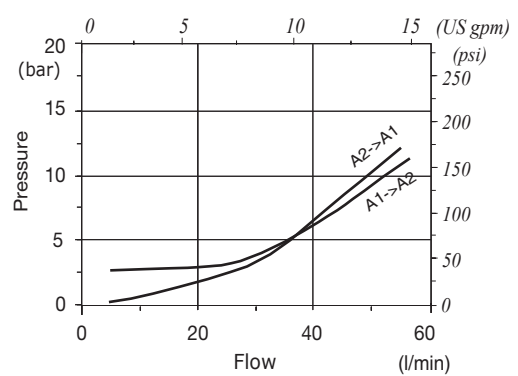

VRDE03A pressure drop vs. flow

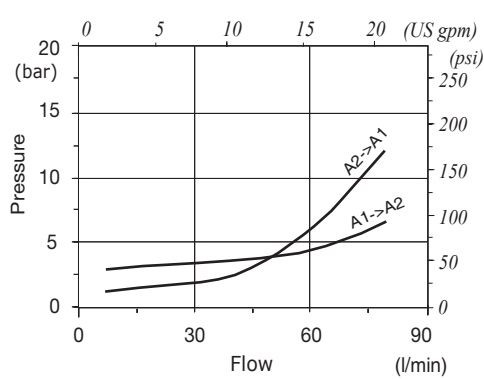



Type VRDE..CIL pilot operated check valves

- Double acting
- With bolt connection

Technical specifications and diagrams are measured with mineral oil of 46 cSt viscosity at 40°C (104°F) temperature.

	VRDE01CIL	VRDE02CIL
Nominal flow	20 l/min (5.3 US gpm)	
Max. pressure	300 bar (4350 psi)	
Oil leakage	0.25 cm ³ /min (0.015 in ³ /min) at 210 bar (3050 psi)	
Fluid	mineral based oil	
Viscosity	from 10 to 200 cSt	
Max. level of contamination	18/16/13 ISO4406	
Fluid temperature	with NBR seals from -20°C (-4°F) to 80°C (176°F)	
Environmental temp. for working conditions	from -40°C (-40°F) to 100°C (212°F)	
Weight	Steel 0.45 kg (0.99 lb)	0.65 kg (1.43 lb)

NOTE - For different conditions, please contact Walvoil Sales Dpt.

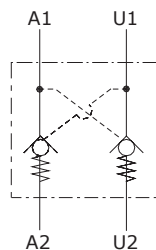

Dimensions

Valve type	All ports
VRDE01CIL	G1/4
VRDE02CIL	G3/8

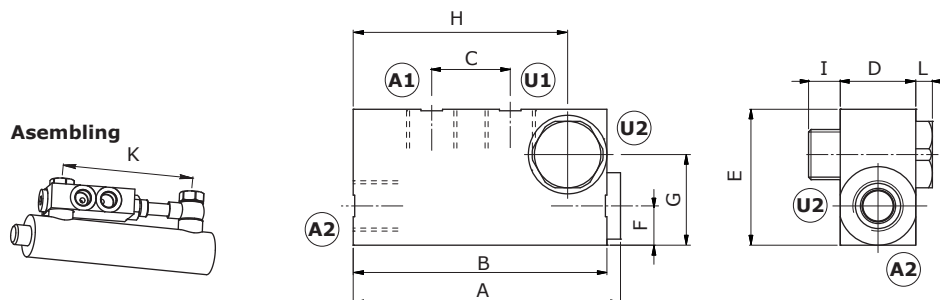

Dimensions are in mm-in

Valve type	A	B	C	D	E	F	G	H	I	L	K min
VRDE01CIL	88.5-3.48	84-3.31	24-0.94	20-0.79	40-1.57	10-0.39	27-1.06	68.5-2.7	10-0.39	6-0.23	123-4.84
VRDE02CIL	90.5-3.56	86-3.38	26-1.02	25-0.98	45-1.77	12-0.47	31-1.22	72-2.83	11-0.43	7-0.27	127-5

Ordering codes and description composition

Port size
VRDE 02 CIL

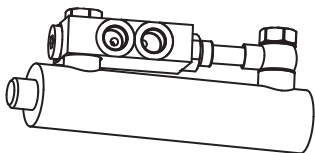

VRDECIL complete valves

TYPE	CODE	DESCRIPTION
VRDE01CIL	1420312100	Steel body, G1/4 port, opening pressure 1 bar (14,5 psi), pilot ratio 1:4.9
VRDE02CIL	1420322100	Steel body, G3/8 port, opening pressure 1 bar (14,5 psi), pilot ratio 1:4.9

For different configurations or SAE threads please contact our Sales Dpt.

Rating diagram

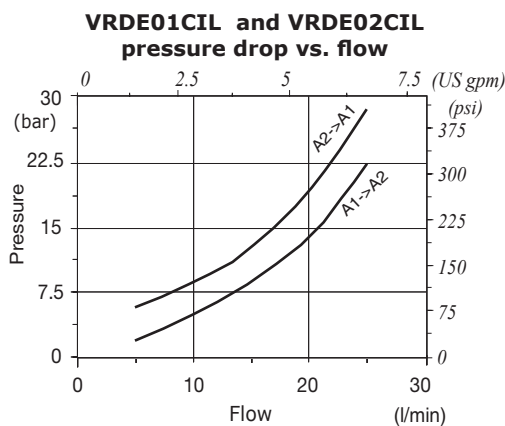

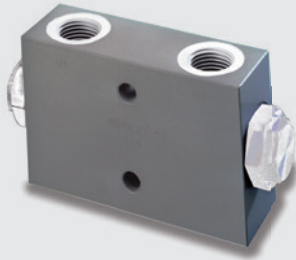

Type VBPD/L/T pilot operated check valves

- Double acting

Technical specifications and diagrams are measured with mineral oil of 46 cSt viscosity at 40°C (104°F) temperature.

	VBPD/L/T 38	VBPD/L/T 12	VBPD/L/T 34	
Nominal flow	25 l/min (6.6 US gpm)	50 l/min (13.2 US gpm)	100 l/min (26.4 US gpm)	
Max. pressure	Aluminium body = 210 bar (3050 psi) Steel body = 350 bar (5100 psi)			
Oil leakage	0.25 cm ³ /min (0.015 in ³ /min) at 210 bar (3050 psi)			
Fluid	mineral based oil			
Viscosity	from 10 to 200 cSt			
Max. level of contamination	18/16/13 ISO4406			
Fluid temperature	with NBR seals from -20°C (-4°F) to 80°C (176°F)			
Environmental temp. for working conditions	from -40°C (-40°F) to 100°C (212°F)			
Weight	aluminium	0.63 kg (1.39 lb)	1.19 kg (2.62 lb)	2.46 kg (5.42 lb)
	steel	1.69 kg (3.73 lb)	2.13 kg (4.70 lb)	5.36 kg (11.81 lb)

NOTE - For different conditions, please contact Walvoil Sales Dpt.

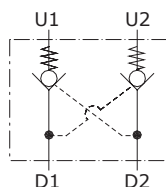

Dimensions

Valve type	All ports	Valve type	All ports
VBPDL/T 38	G3/8	VBPDL/T 38/SAE	SAE8
VBPDL/T 12	G1/2	VBPDL/T 12/SAE	SAE10
VBPDL/T 34	G3/4	VBPDL/T 34/SAE	SAE12

Dimensions are in mm-in

Valve type	A	B	C	D	F	G	ØY
VBPDL/T 38	35-5.39	17.5-5.39	20-0.79	50-1.97	28-1.10	34-1.34	8.5-0.33
VBPDL/T 38/SAE	35-5.39	17.5-5.39	21-0.83	68-2.68	38-1.50	34-1.34	8.5-0.33
VBPDL/T 34	50-1.97	25-0.98	30-1.18	105-4.13	57.5-2.26	50-1.97	8.5-0.33
VBPDL/T 34/SAE	50-1.97	25-0.98	30-1.18	105-4.13	57.5-2.26	50-1.97	8.5-0.33

Valve type	H	I	L	M	O	P	Q
VBPDL/T 38	10-0.39	60-2.36	40-1.57	20-0.79	14.5-0.57	90-3.54	45-1.77
VBPDL/T 38/SAE	10-0.39	60-2.36	40-1.57	20-0.79	14.5-0.57	90-3.54	45-1.77
VBPDL/T 12	15-0.59	70-2.36	40-1.57	20-0.79	13-0.39	110-4.3	55-2.16
VBPDL/T 12/SAE	15-0.59	70-2.36	40-1.57	20-0.79	13-0.39	110-4.3	55-2.16
VBPDL/T 34	15-0.59	90-3.54	60-1.97	30-1.18	16.5-0.65	165-6.50	82.5-3.25
VBPDL/T 34/SAE	15-0.59	90-3.54	60-1.97	30-1.18	16.5-0.65	165-6.50	82.5-3.25

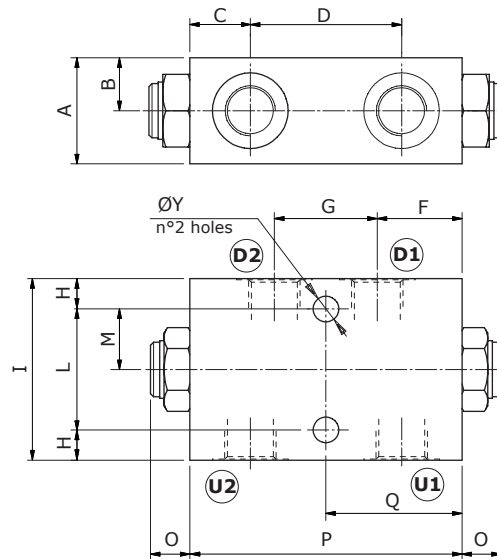

Ordering codes and description composition

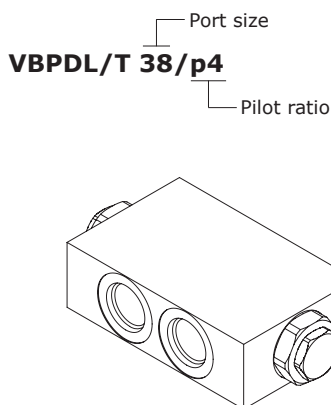

VBPDL/T complete valves

TYPE	CODE	DESCRIPTION
VBPDL/T 38/p4	1422021100	Aluminium body, pilot ratio 1:4, G3/8 ports
VBPDL/T 38/p4/ac	1422022100	Steel body, as previous one
VBPDL/T 12/p4	1422031100	Aluminium body, pilot ratio 1:4, G1/2 ports
VBPDL/T 12/p4/ac	1422032100	Steel body, as previous one
VBPDL/T 34/p4	1422041100	Aluminium body, pilot ratio 1:4, G3/4 ports
VBPDL/T 34/p4/ac	1422042100	Steel body, as previous one
VBPDL/T 38/p4/SAE	1422021200	Aluminium body, pilot ratio 1:4, SAE8 ports
VBPDL/T 38/p4/ac/SAE	1422022200	Steel body, as previous one
VBPDL/T 12/p4/SAE	1422031200	Aluminium body, pilot ratio 1:4, SAE10 ports
VBPDL/T 34/p4/SAE	1422041200	Aluminium body, pilot ratio 1:4, SAE12 ports

For other steel body configurations, other port sizes and configurations with FPM (Viton) seals please contact our Sales Dept.

Rating diagram

VBPDL/T 38 pressure drop vs. flow

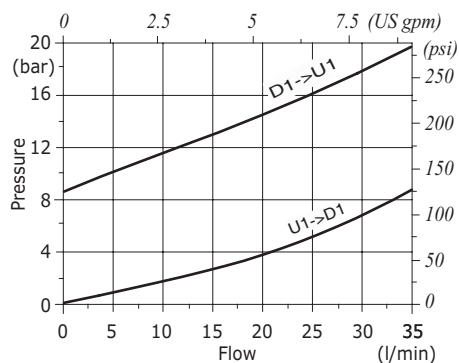

VBPDL/T 12 pressure drop vs. flow

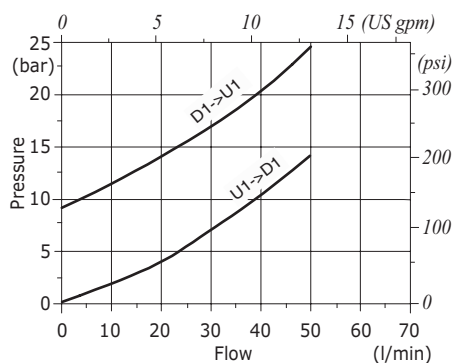

VBPDL/T 34 pressure drop vs. flow

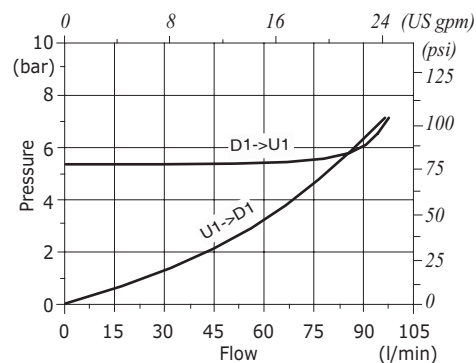



Type VBPD L/SO pilot operated check valves

- Double acting
- With bolt connection

Technical specifications and diagrams are measured with mineral oil of 46 cSt viscosity at 40°C (104°F) temperature.

	VBPD L 14/SO	VBPD L/VP 38/SO	VBPD L 38/SO	VBPD L 12/SO	
Nominal flow	15 l/min (4.0 US gpm)	25 l/min (6.6 US gpm)	35 l/min (9.2 US gpm)	50 l/min (13.2 US gpm)	
Max. pressure	Aluminium body = 210 bar (3050 psi) Steel body = 350 bar (5100 psi)				
Oil leakage	0.25 cm ³ /min (0.015 in ³ /min) at 210 bar (3050 psi)				
Fluid	mineral based oil				
Viscosity	from 10 to 200 cSt				
Max. level of contamination	18/16/13 ISO4406				
Fluid temperature	with NBR seals from -20°C (-4°F) to 80°C (176°F)				
Environmental temp. for working conditions	from -40°C (-40°F) to 100°C (212°F)				
Weight	aluminium	0.60 kg (1.32 lb)	0.60 kg (1.32 lb)	0.77 kg (1.70 lb)	0.80 kg (1.76 lb)
	steel	/	/	1.43 kg (3.15 lb)	1.43 kg (3.15 lb)

NOTE - For different conditions, please contact Walvoil Sales Dpt.

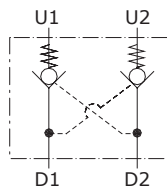

Dimensions

VBPDL 14/SO and VBPDL/VP 38/SO valves

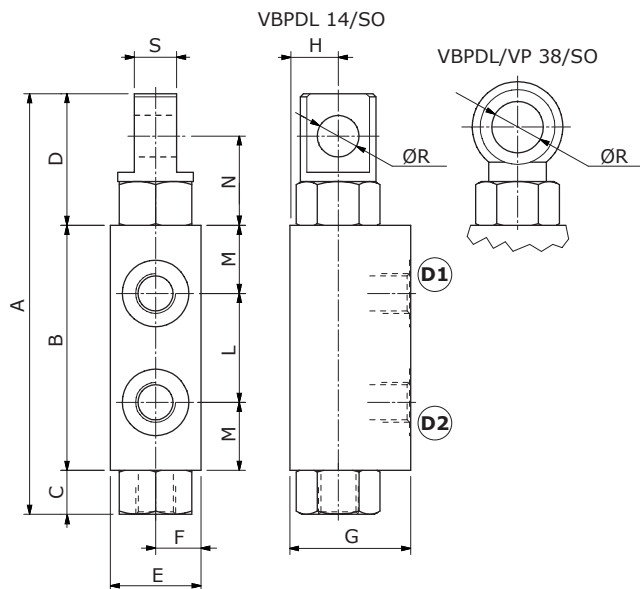

VBPDL 38/SO and VBPDL 12/SO valves

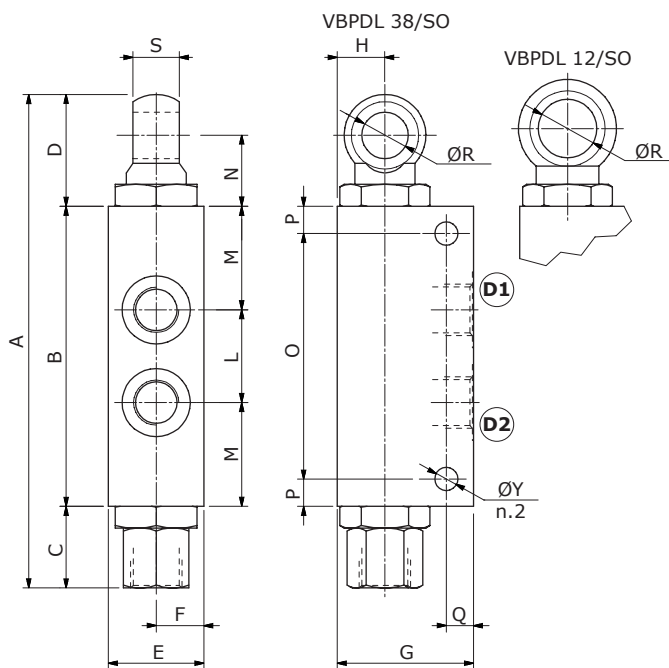

Valve type	All ports
VBPDL 14/SO	G1/4
VBPDL/VP 38/SO	G3/8
VBPDL 38/SO	G3/8
VBPDL 12/SO	G1/2

Dimensions are in mm-in

Valve type	A	B	C	D	E	F	G	H	L	M	N	O	P	Q	ØR	S	ØY
VBPDL 14/SO	139 5.47	81 3.19	14.5 0.57	43.5 1.71	30 1.18	15 0.59	40 1.57	16 0.63	36 1.42	22.5 0.88	29.5 1.16	/	/	/	13.7 0.54	14 0.55	/
VBPDL/VP 38/SO	5.83 4.72	81 3.19	19.5 0.77	47.5 1.87	30 1.18	15 0.59	40 1.57	16 0.63	36 1.42	22.5 0.88	32.5 1.28	/	/	/	17 0.67	17 0.67	/
VBPDL 38/SO	181 7.13	110 4.33	30 1.18	41 1.61	35 1.38	17.5 0.69	50 1.97	17.5 0.69	34 1.34	38 1.50	26 1.02	90 3.54	10 0.39	10 0.39	17 0.67	17 0.67	8.5 0.33
VBPDL 12/SO	190.5 7.50	110 4.33	33 1.30	47.5 1.87	35 1.38	17.5 0.69	XXX XXX	17.5 0.69	34 1.34	38 1.50	28.5 1.12	90 3.54	10 0.39	10 0.39	21.2 0.83	23.5 0.93	8.5 0.33

Ordering codes and description composition

Port size
VBPDL 14/SO/p4
Pilot ratio

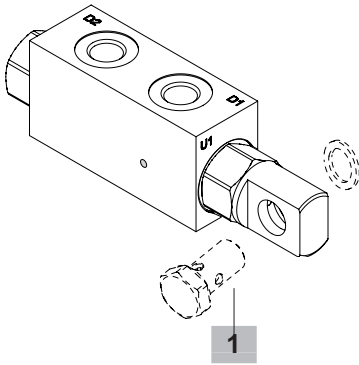

VBPDL/SO complete valves

TYPE	CODE	DESCRIPTION
VBPDL 14/SO/p4	1421011100	Aluminium body, pilot ratio 1:4, G1/4 ports
VBPDL /VP 38/SO/p4	1421011150	Aluminium body, pilot ratio 1:4, G3/8 ports
VBPDL 38/SO/p4	1421021100	Aluminium body, pilot ratio 1:4, G3/8 ports
VBPDL 38/SO/p4/ac	1421022100	Steel body, as previous one
VBPDL 12/SO/p4	1421031100	Aluminium body, pilot ratio 1:4, G1/2 ports
VBPDL 12/SO/p4/ac	1421032100	Steel body, as previous one

For other steel body configurations, SAE thread and configurations with FPM (Viton) seals please contact our Sales Dpt.

1 Joint kit with washer

TYPE	CODE	DESCRIPTION
1/4"	4XBR1110240	G1/4 ports
3/8"	4XBR1120310	G3/8 ports
1/2"	4XBR1130380	G1/2 ports

Rating diagrams

VBPDL 14/SO pressure drop vs. flow

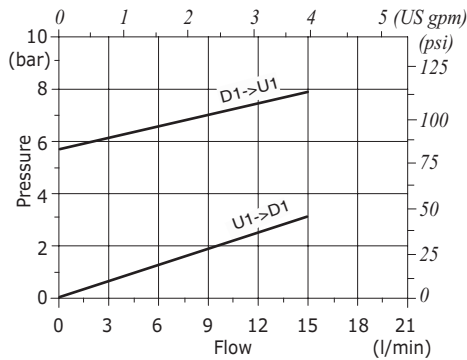

VBPDL/VP 38/SO pressure drop vs. flow

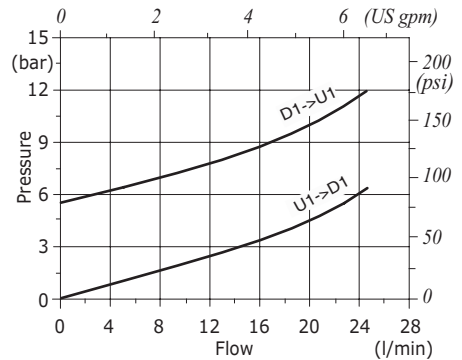

VBPDL 38/SO pressure drop vs. flow

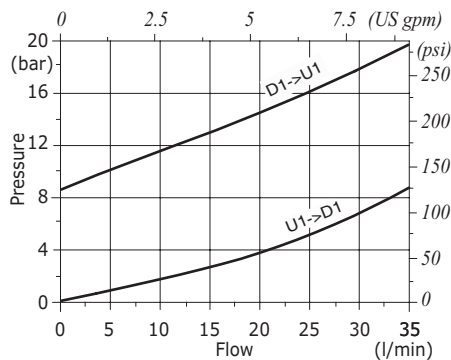

VBPDL 12/SO pressure drop vs. flow

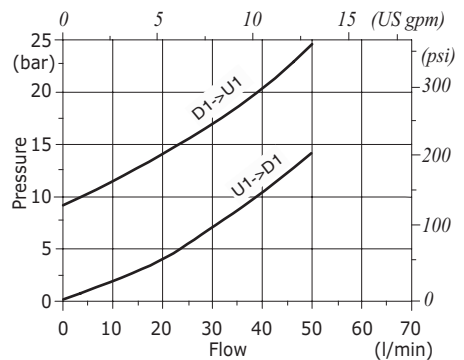



Type VBPDF pilot operated check valves

- Double acting
- Face mounting

Technical specifications and diagrams are measured with mineral oil of 46 cSt viscosity at 40°C (104°F) temperature.

	VBPDF 14	VBPDF 38	VBPDF 12	VBPDF 34	
Nominal flow	15 l/min (4.0 US gpm)	35 l/min (9.2 US gpm)	50 l/min (13.2 US gpm)	100 l/min (26.4 US gpm)	
Max. pressure	Aluminium body = 210 bar (3050 psi) Steel body = 350 bar (5100 psi)				
Oil leakage	0.25 cm ³ /min (0.015 in ³ /min) at 210 bar (3050 psi)				
Fluid	mineral based oil				
Viscosity	from 10 to 200 cSt				
Max. level of contamination	18/16/13 ISO4406				
Fluid temperature	with NBR seals from -20°C (-4°F) to 80°C (176°F)				
Environmental temp. for working conditions	from -40°C (-40°F) to 100°C (212°F)				
Weight	<i>aluminium</i>	0.47 kg (1.04 lb)	1.17 kg (2.58 lb)	1.15 kg (2.54 lb)	2.52 kg (5.56 lb)
	<i>steel</i>	0.95 kg (2.09 lb)	2.13 kg (4.70 lb)	2.05 kg (4.52 lb)	5.23 kg (11.53 lb)

NOTE - For different conditions, please contact Walvoil Sales Dpt.

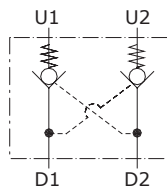

Dimensions

Valve type	D1 - D2	U1 - U2
VBPDF 14	G1/4	∅ 5 ∅ 0.20
VBPDF 38	G3/8	∅ 7 ∅ 0.27
VBPDF 12	G1/2	∅ 7 ∅ 0.27
VBPDF 34	G3/4	∅ 14 ∅ 0.55

Valve type	D1 - D2	U1 - U2
VBPDF 12/SAE	SAE10	∅ 7 ∅ 0.27

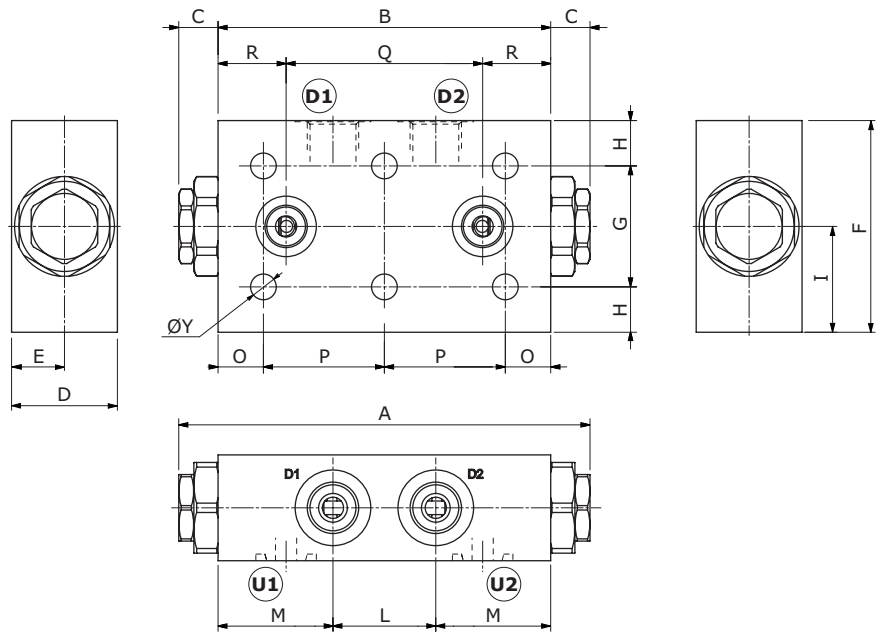

Dimensions are in mm-in

Valve type	A	B	C	D	E	F	G	H	I	L	M	O	P	Q	R	ØY
VBPDF 14	119 4.69	90 3.54	14.5 0.57	30 1.18	15 0.59	50 1.97	35 1.38	7.5 0.29	17.5 0.69	30 1.18	30 1.18	8.5 0.33	36.5 1.44	55 2.16	17.5 0.69	6.5 0.25
VBPDF 38	136 5.35	110 4.33	13 0.51	35 1.38	17.5 0.69	70 2.75	40 1.57	15 0.59	20 0.79	34 1.34	38 1.50	15 0.59	40 1.57	65 2.56	22.5 0.88	8.5 0.33
VBPDF 12 VBPDF 12/SAE	136 5.35	110 4.33	13 0.51	35 1.38	17.5 0.69	70 2.75	40 1.57	15 0.59	20 0.79	34 1.34	38 1.50	15 0.59	40 1.57	65 2.56	22.5 0.88	8.5 0.33
VBPDF 34	198 7.80	165 6.50	16.5 0.71	49 1.93	24.5 0.96	90 3.54	50 1.97	20 0.79	55 2.17	50 1.97	57.5 2.26	15 0.59	67.5 2.65	105 4.13	30 1.18	10.5 0.41

Ordering codes and description composition

Port size
VBPDF 14/p4
Pilot ratio

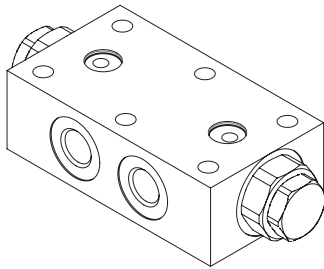

VBPDF complete valves

TYPE	CODE	DESCRIPTION
VBPDF 14/p4	1426011100	Aluminium body, pilot ratio 1:4, G1/4 ports
VBPDF 14/p4/ac	1426012100	Steel body, as previous one
VBPDF 38/p4	1426021100	Aluminium body, pilot ratio 1:4, G3/8 ports
VBPDF 38/p4/ac	1426022100	Steel body, as previous one
VBPDF 12/p4	1426031100	Aluminium body, pilot ratio 1:4, G1/2 ports
VBPDF 12/p4/ac	1426032100	Steel body, as previous one
VBPDF 34/p4	1426041100	Aluminium body, pilot ratio 1:4, G3/4 ports
VBPDF 34/p4/ac	1426042100	Steel body, as previous one
VBPDF 12/p4/SAE	1426031200	Aluminium body, pilot ratio 1:4, SAE10 ports
VBPDF 12/p4/ac/SAE	1426032200	Steel body, as previous one

For other steel body configurations, SAE threads and configurations with FPM (Viton) seals, please contact our Sales Dpt.

Rating diagrams

VBPDF 14 pressure drop vs. flow

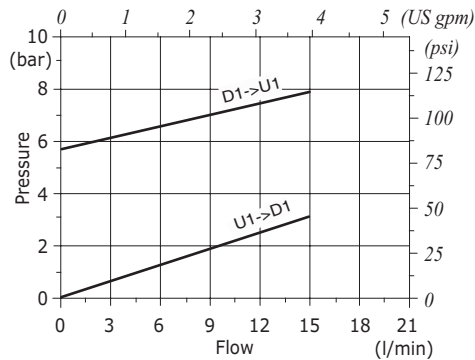

VBPDF 38 pressure drop vs. flow

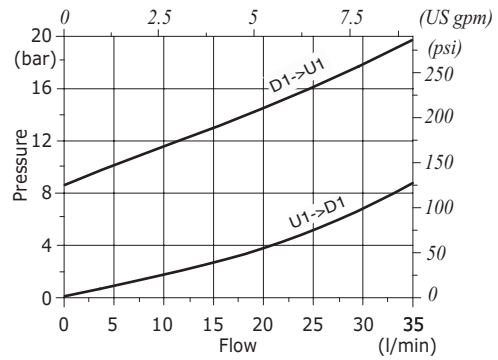

VBPDF 12 pressure drop vs. flow

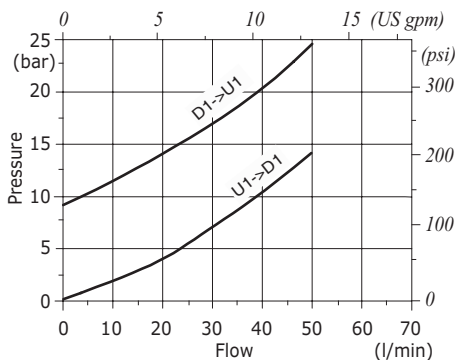

VBPDF 34 pressure drop vs. flow

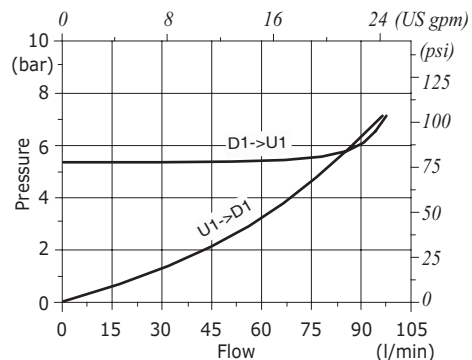

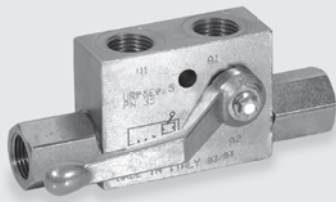

Type VBPD/L/R pilot operated check valves

- Double acting
- Check valve by pass type

Technical specifications and diagrams are measured with mineral oil of 46 cSt viscosity at 40°C (104°F) temperature.

	VBPD/L/R/..14	VBPD/L/VP/R/..38	VBPD/L/R/..38	VBPD/L/VP/R/..12
Nominal flow	25 l/min (6.6 US gpm)		50 l/min (13.2 US gpm)	
Max. pressure	350 bar (5100 psi)		300 bar (4350 psi)	
Oil leakage	0.25 cm ³ /min (0.015 in ³ /min) at 210 bar (3050 psi)			
Fluid	mineral based oil			
Viscosity	from 10 to 200 cSt			
Max. level of contamination	18/16/13 ISO4406			
Fluid temperature	with NBR seals from -20°C (-4°F) to 80°C (176°F)			
Environmental temp. for working conditions	from -40°C (-40°F) to 100°C (212°F)			
Weight	steel	0.95 kg (2.09 lb)	0.95 kg (2.09 lb)	1.12 kg (2.47 lb)

NOTE - For different conditions, please contact Walvoil Sales Dpt.

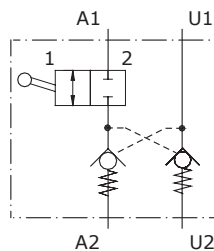

Dimension

Valve type	All ports
VBPDL/R/..14	G1/4
VBPDL/VP/R/..38	G3/8
VBPDL/R/..38	G3/8
VBPDL/VP/R/..12	G1/2

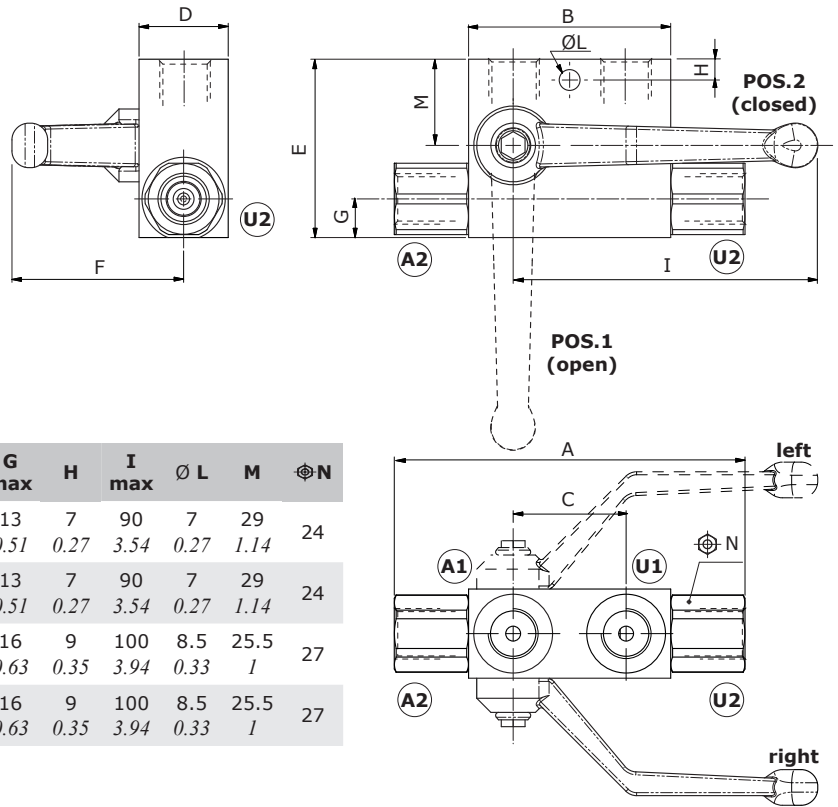

Dimensions are in mm-in

Valve type	A	B	C	D	E	F max	G max	H	I max	Ø L	M	⊕N
VBPDL/R/..14	118	68	38	30	60	65	13	7	90	7	29	24
	4.64	2.68	1.50	1.18	2.36	2.56	0.51	0.27	3.54	0.27	1.14	
VBPDL/VP/R/..38	118	68	38	30	60	65	13	7	90	7	29	24
	4.64	2.68	1.50	1.18	2.36	2.56	0.51	0.27	3.54	0.27	1.14	
VBPDL/R/..38	143	80	40	30	60	60	16	9	100	8.5	25.5	27
	5.63	3.15	1.57	1.18	2.36	2.36	0.63	0.35	3.94	0.33	1	
VBPDL/VP/R/..12	143	80	40	30	60	60	16	9	100	8.5	25.5	27
	5.63	3.15	1.57	1.18	2.36	2.36	0.63	0.35	3.94	0.33	1	

Ordering codes and description composition

D - right
S - left
Port size

VBPDL/R/ D 14

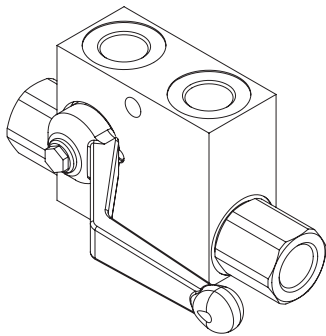

VBPDLR complete valves

TYPE	CODE	DESCRIPTION
VBPDL/R/S 14/p4,5/Pa4/ac	1425312100	Steel body, opening press. 4 bar (58 psi), pilot ratio 1:4.5, G1/4 ports, left lever
VBPDL/R/D 14/p4,5/Pa4/ac	1425312101	As previous with right lever
VBPDL/R/S 38/p4/Pa4/ac	1425322100	Steel body, opening press. 4 bar (58 psi), pilot ratio 1:4, G3/8 ports, left lever
VBPDL/R/D 38/p4/Pa4/ac	1425322101	As previous with right lever
VBPDL/VP/R/S 38/p4,5/Pa4/ac	1425322102	Steel body, opening press. 4 bar (58 psi), pilot ratio 1:4, G3/8 ports, left lever
VBPDL/VP/R/D 38/p4,5/Pa4/ac	1425322103	As previous with right lever
VBPDL/VP/R/S 12/p4/Pa4/ac	1425332100	Steel body, opening press. 4 bar (58 psi), pilot ratio 1:4, G1/2 ports, left lever
VBPDL/VP/R/D 12/p4/Pa4/ac	1425332101	As previous with right lever

For different configurations or SAE threads please contact our Sales Dpt.

Rating diagram

VBPDL/R/..14 pressure drop vs. flow

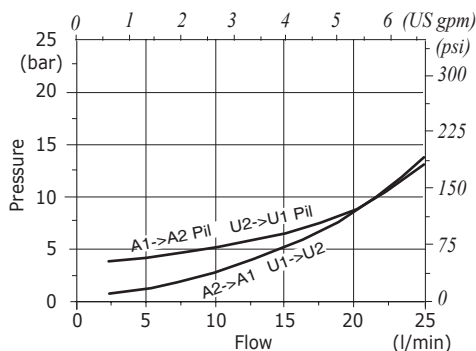

VBPDL/R/..38 pressure drop vs. flow

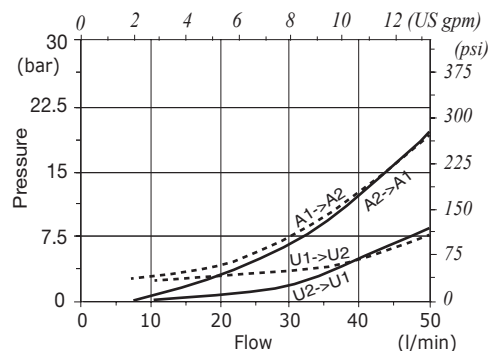



Type VRPDE..A pilot operated check valves



- Double acting
- Check valve DIN 2353 by pass type
- Shut-off

Technical specifications and diagrams are measured with mineral oil of 46 cSt viscosity at 40°C (104°F) temperature.

	VRPDE01A	VRPDE015A	VRPDE02A	VRPDE025A
Nominal flow	25 l/min (6.6 US gpm)		50 l/min (13.2 US gpm)	
Max. pressure	350 bar (5100 psi)		300 bar (4350 psi)	
Oil leakage	0.25 cm ³ /min (0.015 in ³ /min) at 210 bar (3050 psi)			
Fluid	mineral based oil			
Viscosity	from 10 to 200 cSt			
Max. level of contamination	18/16/13 ISO4406			
Fluid temperature	with NBR seals from -20°C (-4°F) to 80°C (176°F)			
Environmental temp. for working conditions	from -40°C (-40°F) to 100°C (212°F)			
Weight	steel	0.95 kg (2.09 lb)	0.95 kg (2.09 lb)	1.12 kg (2.47 lb)

NOTE - For different conditions, please contact Walvoil Sales Dpt.

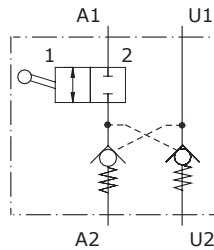

Dimension

Valve type	A1-U1	A2-U2
VRPDE01A	G1/4	12 0.27
VRPDE015A	G3/8	12 0.27
VRPDE02A	G3/8	15 0.59
VRPDE025A	G1/2	15 0.59

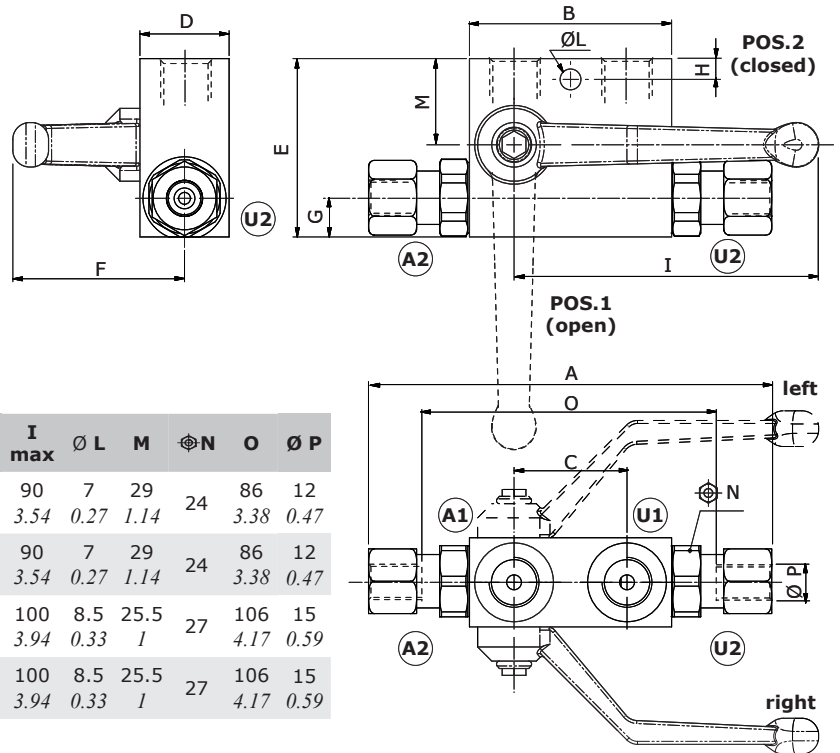

Dimensions are in mm-in

Valve type	A	B	C	D	E	F max	G max	H	I max	Ø L	M	Ø N	O	Ø P
VRPDE01A	138 5.43	68 2.68	38 1.50	30 1.18	60 2.36	65 2.56	13 0.51	7 0.27	90 3.54	7 0.27	29 1.14	24	86 3.38	12 0.47
VRPDE015A	138 5.43	68 2.68	38 1.50	30 1.18	60 2.36	65 2.56	13 0.51	7 0.27	90 3.54	7 0.27	29 1.14	24	86 3.38	12 0.47
VRPDE02A	140 5.51	80 3.15	40 1.57	30 1.18	60 2.36	60 2.36	16 0.63	9 0.35	100 3.94	8.5 0.33	25.5 1	27	106 4.17	15 0.59
VRPDE025A	140 5.51	80 3.15	40 1.57	30 1.18	60 2.36	60 2.36	16 0.63	9 0.35	100 3.94	8.5 0.33	25.5 1	27	106 4.17	15 0.59

Ordering codes and description composition

Port size
R - right
L - left
VRPDE 01 A R

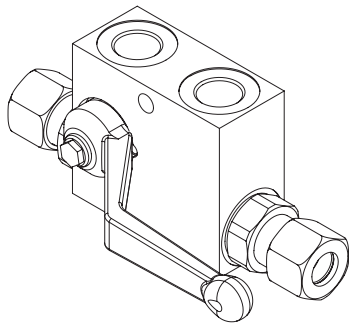

VRPDE complete valves

TYPE	CODE	DESCRIPTION
VRPDE01AR	1425412100	Steel body, opening press. 4 bar (58 psi), pilot ratio 1:4.5, G1/4 ports, right lever
VRPDE015AL	1425422102	Steel body, opening press. 4 bar (58 psi), pilot ratio 1:4.5, G3/8 ports, left lever
VRPDE015AR	1425422103	Steel body, opening press. 4 bar (58 psi), pilot ratio 1:4.5, G3/8 ports, right lever
VRPDE02AL	1425422100	Steel body, opening press. 4 bar (58 psi), pilot ratio 1:4, G3/8 ports, left lever
VRPDE02AR	1425422101	Steel body, opening press. 4 bar (58 psi), pilot ratio 1:4, G3/8 ports, right lever
VRPDE025AL	1425432100	Steel body, opening press. 4 bar (58 psi), pilot ratio 1:4, G1/2 ports, left lever
VRPDE025AR	1425432101	Steel body, opening press. 4 bar (58 psi), pilot ratio 1:4, G1/2 ports, right lever

For different configurations or SAE thread please contact our Sales Dept.

Rating diagram

VRPDE 01 A pressure drop vs. flow

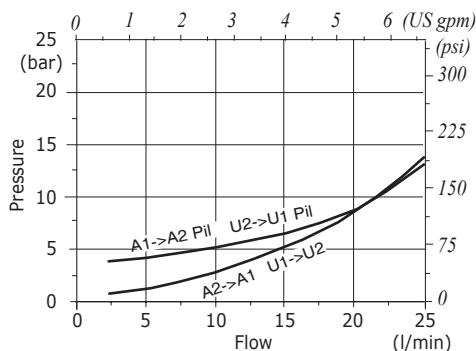

VRPDE 02 A pressure drop vs. flow

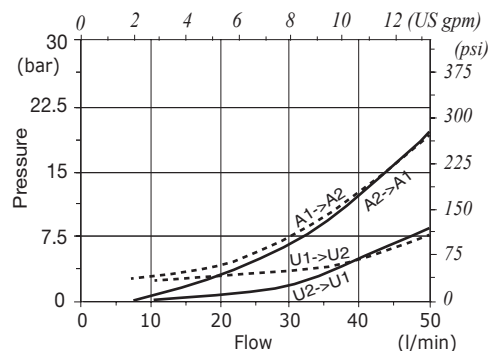

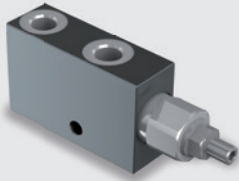

Type VOSL/N78/.... counterbalance valves

- Single acting
- Load sensitive

Technical specifications and diagrams are measured with mineral oil of 46 cSt viscosity at 40°C (104°F) temperature.

VOSL/N78 - VOSL/N78/..PB

Nominal flow	40 l/min (10.57 US gpm)
Max. pressure	Steel body = 350 bar (5100 psi)
Oil leakage	0.25 cm ³ /min - 0.015 in ³ /min. (5 drops) at 80% of pressure setting
Fluid	mineral based oil
Viscosity	from 10 to 200 cSt
Max. level of contamination	18/16/13 ISO4406
Fluid temperature	with NBR seals from -20°C (-4°F) to 80°C (176°F)
Environmental temp. for working conditions	from -40°C (-40°F) to 100°C (212°F)
	steel
	0.723 kg (1.59 lb)

NOTE - For different conditions, please contact Walvoil Sales Dpt.

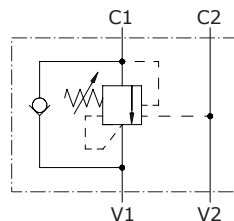

Dimensions

VOSL/N78/14

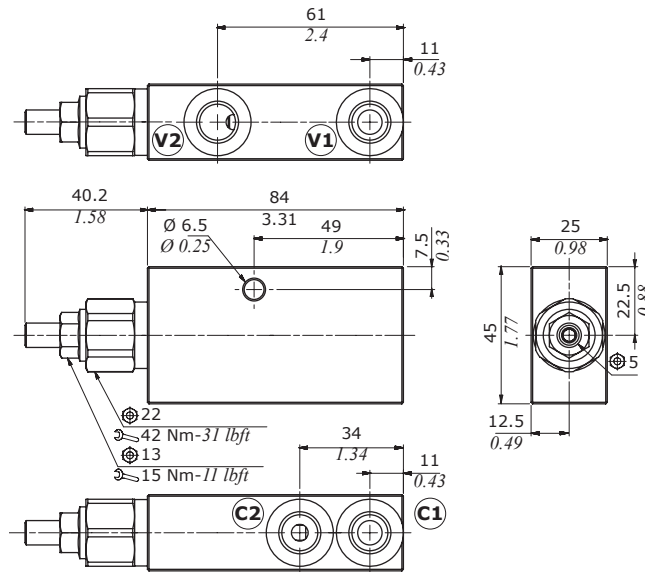

Valve type	V1	V2	C1	C2
------------	----	----	----	----

VOSL/N78/14 G1/4 G1/4

VOSL/N78/14PB G1/4 G1/4

Valve type	V1	V2	C1	C2
------------	----	----	----	----

VOSL/N78/S6 SAE6 SAE6

VOSL/N78/14PB

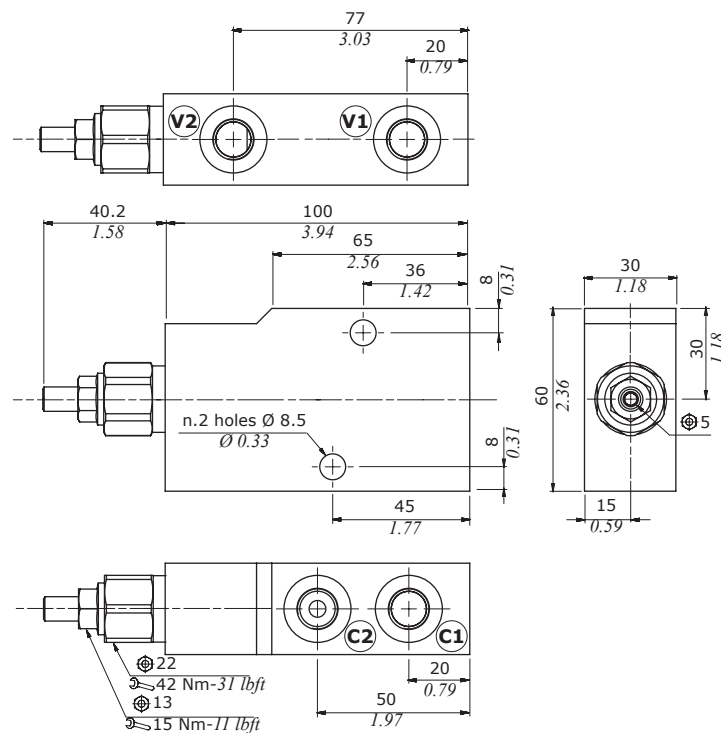

Ordering codes and description composition

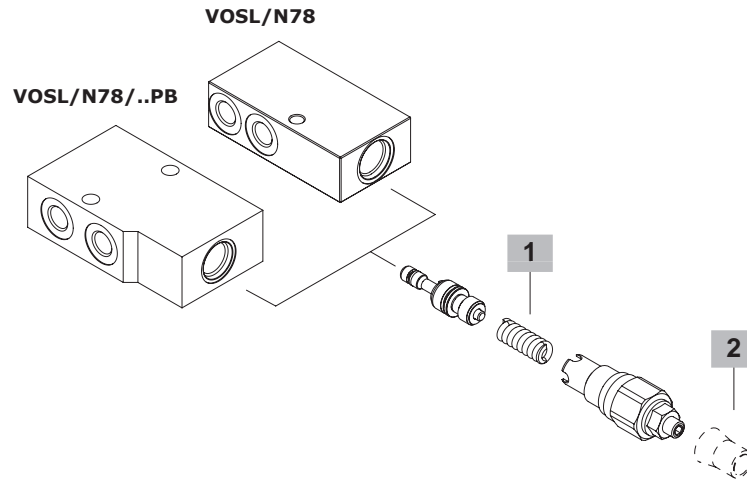
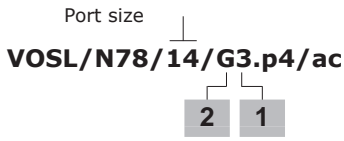

VOSL/N78 complete valves

TYPE: **VOSL/N78/14/G5.p4/ac** CODE: 1513512100
DESCRIPTION: Steel body, pilot ratio 1:4, range 100-350 bar (1450-5075 psi), standard setting 280 bar (4060 psi) @ 5 l/min (1.32 US gpm)

TYPE: **VOSL/N78/14/G3.p4/ac** CODE: 1513512101
DESCRIPTION: Steel body, pilot ratio 1:4, range 60-220 bar (870-3190 psi), standard setting 150 bar (2170 psi) @ 5 l/min (1.32 US gpm)

TYPE: **VOSL/N78/S6/G5.p4/ac** CODE: 1513512200
DESCRIPTION: Steel body, pilot ratio 1:4, range 100-350 bar (1450-5075 psi), standard setting 280 bar (4060 psi) @ 5 l/min (1.32 US gpm)

TYPE: **VOSL/N78/S6/G3.p4/ac** CODE: 1513512201
DESCRIPTION: Steel body, pilot ratio 1:4, range 60-220 bar (870-3190 psi), standard setting 150 bar (2170 psi) @ 5 l/min (1.32 US gpm)

VOSL/N78....PB complete valves

TYPE: **VOSL/N78/14PB/G5.p4/ac** CODE: 1513612100
DESCRIPTION: Steel body, pilot ratio 1:4, range 100-350 bar (1450-5075 psi), standard setting 280 bar (4060 psi) @ 5 l/min (1.32 US gpm)

TYPE: **VOSL/N78/14PB/G3.p4/ac** CODE: 1513612101
DESCRIPTION: Steel body, pilot ratio 1:4, range 60-220 bar (870-3190 psi), standard setting 150 bar (2170 psi) @ 5 l/min (1.32 US gpm)

1 Pressure setting spring

TYPE	CODE	DESCRIPTION
For 1:4 pilot ratio		
3	3MOL310282	For range 60-220 bar (870-3190 psi) standard setting 150 bar (2170 psi) @ 5 l/min (1.32 US gpm)
5	380113	For range 100-350 bar (1450-5075 psi) standard setting 280 bar (4060 psi) @ 5 l/min (1.32 US gpm)

2 Setting type

TYPE	CODE	DESCRIPTION
G	-	Screw setting
Z	4COP120420	Antitampering cap

Rating diagrams

Pressure drop vs. flow from C2->V2 and V2->C2

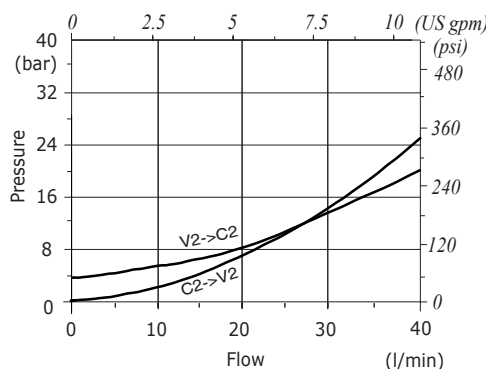

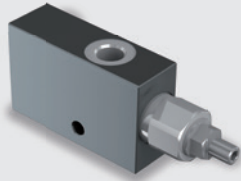

Type VOSLP/N78/.... counterbalance valves

- Single acting
- External pilot

Technical specifications and diagrams are measured with mineral oil of 46 cSt viscosity at 40°C (104°F) temperature.

VOSLP/N78 - VOSLP/N78/..PB

Nominal flow	40 l/min (10.57 US gpm)
Max. pressure	Steel body = 350 bar (5100 psi)
Oil leakage	0.25 cm ³ /min - 0.015 in ³ /min. (5 drops) at 80% of pressure setting
Fluid	mineral based oil
Viscosity	from 10 to 200 cSt
Max. level of contamination	18/16/13 ISO4406
Fluid temperature	with NBR seals from -20°C (-4°F) to 80°C (176°F)
Environmental temp. for working conditions	from -40°C (-40°F) to 100°C (212°F)
	steel
	0.723 kg (1.59 lb)

NOTE - For different conditions, please contact Walvoil Sales Dpt.

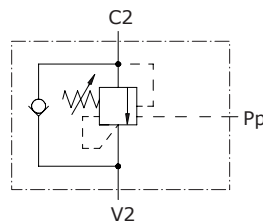

Dimensions

VOSLP/N78/14

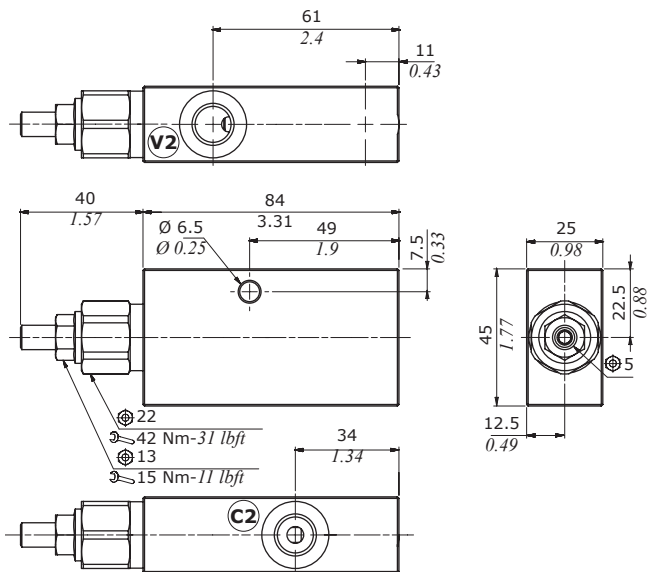

Valve type	V1	V2	C1	C2
VOSLP/N78/14	G1/4	G1/4		
Valve type	V1	V2	C1	C2
VOSLP/N78/S6	SAE6	SAE6		

Rating diagrams

Pressure drop vs. flow
from C2->V2 and V2->C2

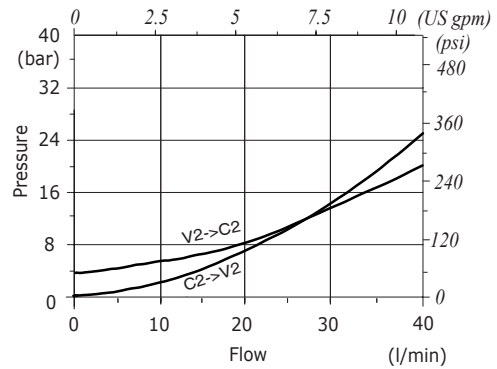

Ordering codes and description composition

Port size
VOSLP/N78/14/G3.p4/ac



VOSLP/N78

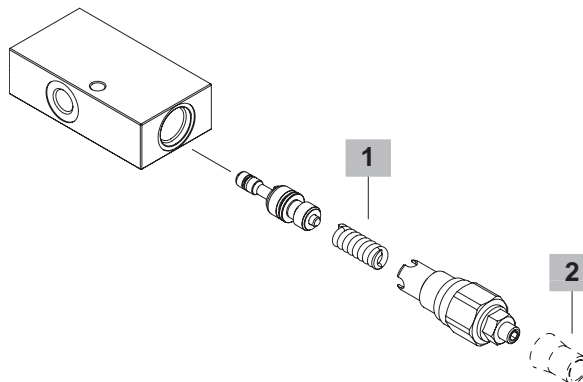

VOSLP/N78 complete valves

TYPE: **VOSLP/N78/14/G5.p4/ac** CODE: 1533612100
 DESCRIPTION: Steel body, pilot ratio 1:4, range 100-350 bar (1450-5075 psi), standard setting 280 bar (4060 psi) @ 5 l/min (1.32 US gpm)
 TYPE: **VOSLP/N78/14/G3.p4/ac** CODE: 1533612101
 DESCRIPTION: Steel body, pilot ratio 1:4, range 60-220 bar (870-3190 psi), standard setting 150 bar (2170 psi) @ 5 l/min (1.32 US gpm)
 TYPE: **VOSLP/N78/S6/G5.p4/ac** CODE: 1533612200
 DESCRIPTION: Steel body, pilot ratio 1:4, range 100-350 bar (1450-5075 psi), standard setting 280 bar (4060 psi) @ 5 l/min (1.32 US gpm)
 TYPE: **VOSLP/N78/S6/G3.p4/ac** CODE: 1533612201
 DESCRIPTION: Steel body, pilot ratio 1:4, range 60-220 bar (870-3190 psi), standard setting 150 bar (2170 psi) @ 5 l/min (1.32 US gpm)

1 Pressure setting spring

TYPE	CODE	DESCRIPTION
3	3MOL310282	For range 60-220 bar (870-3190 psi) standard setting 150 bar (2170 psi) @ 5 l/min (1.32 US gpm)
5	380113	For range 100-350 bar (1450-5075 psi) standard setting 280 bar (4060 psi) @ 5 l/min (1.32 US gpm)

2 Setting type

TYPE	CODE	DESCRIPTION
G	-	Screw setting
Z	4COP120420	Antitampering cap

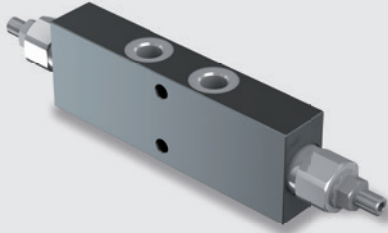

Type VODL/N78 /.... counterbalance valves

- Double acting
- Load sensitive

Technical specifications and diagrams are measured with mineral oil of 46 cSt viscosity at 40°C (104°F) temperature.

VODL/N78 - VODL/N78/..PB

Nominal flow	40 l/min (10.57 US gpm)
Max. pressure	Steel body = 350 bar (5100 psi)
Oil leakage	0.25 cm ³ /min - 0.015 in ³ /min. (5 drops) at 80% of pressure setting
Fluid	mineral based oil
Viscosity	from 10 to 200 cSt
Max. level of contamination	18/16/13 ISO4406
Fluid temperature	with NBR seals from -20°C (-4°F) to 80°C (176°F)
Environmental temp. for working conditions	from -40°C (-40°F) to 100°C (212°F)
	steel
	1.25 kg (2.75 lb)

NOTE - For different conditions, please contact Walvoil Sales Dpt.

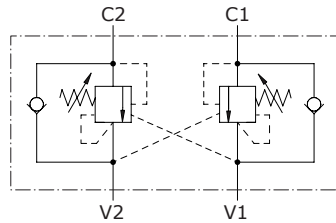

Dimensions

VODL/N78/14

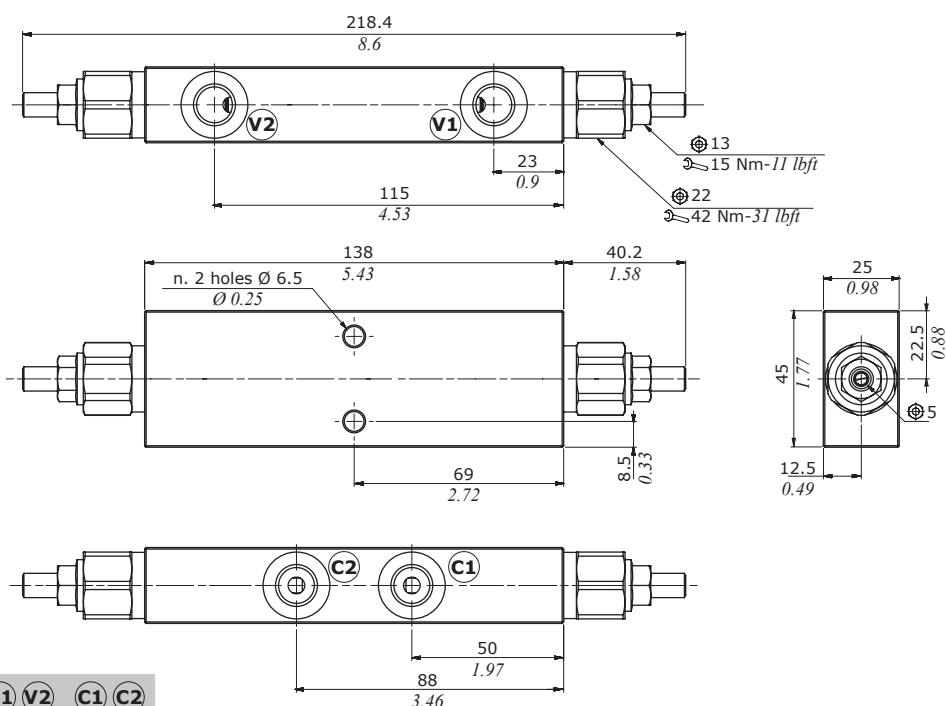

Tipo valvola	V1	V2	C1	C2
VODL/N78/14	G1/4	G1/4		
VODL/N78/14PB	G1/4	G1/4		

Tipo valvola	V1	V2	C1	C2
VODL/N78/S6	SAE6	SAE6		

VODL/N78/14PB

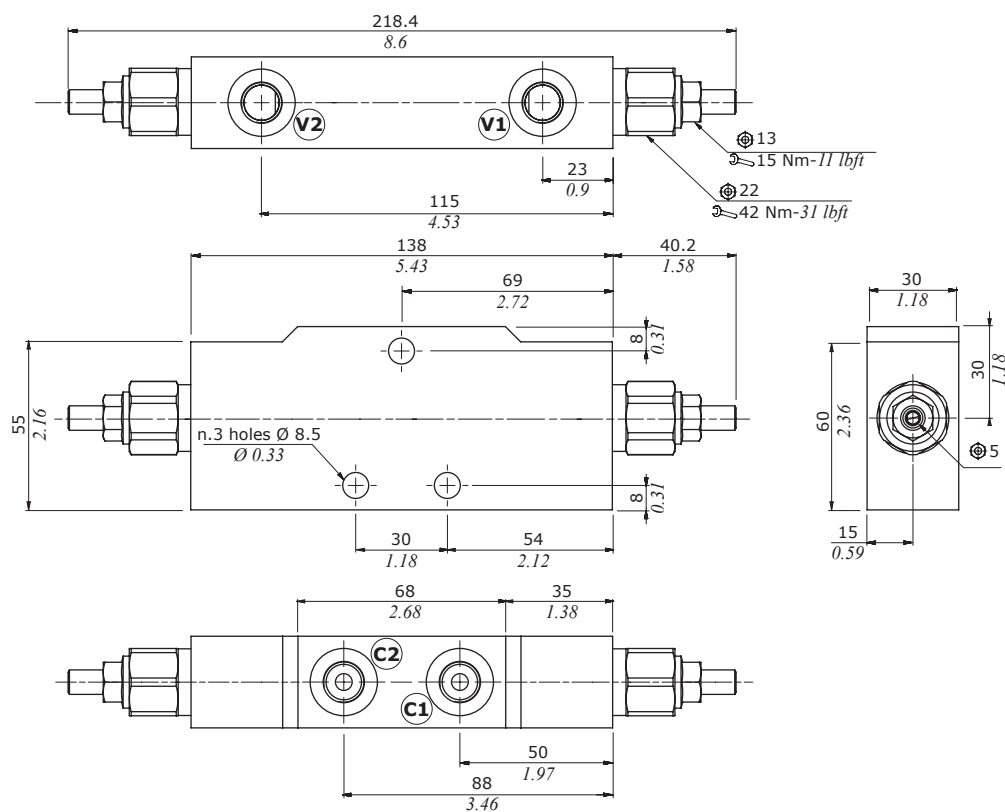

Ordering codes and description composition

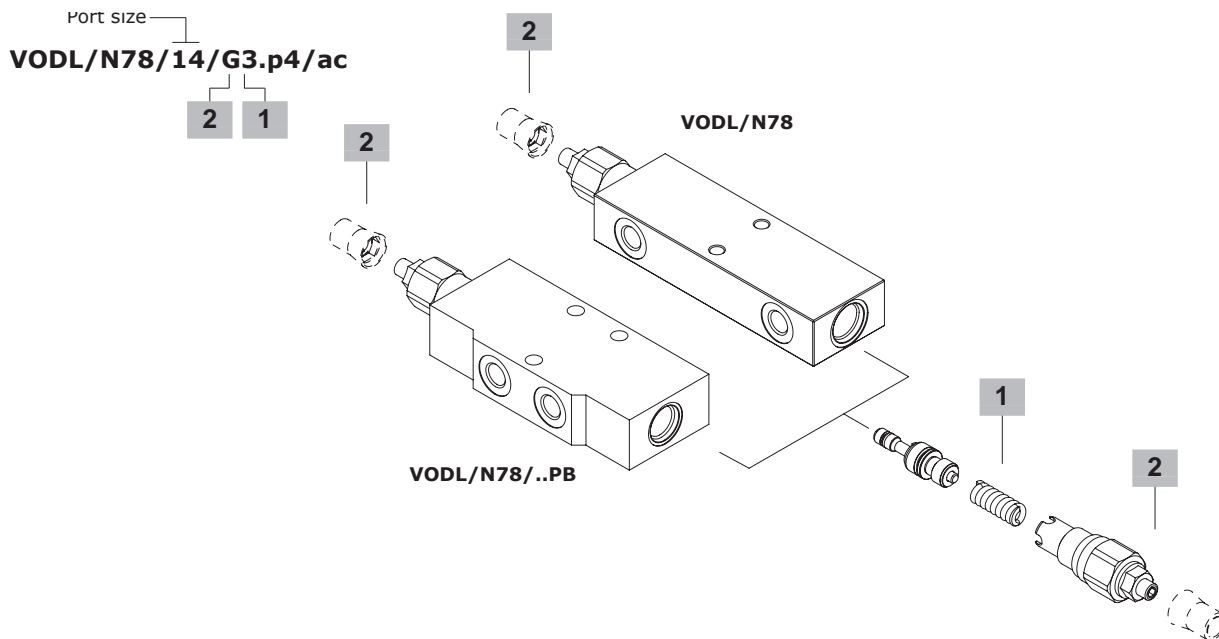

VODL/N78 complete valves

TYPE: **VODL/N78/14/G5.p4/ac** CODE: 1553612100
 DESCRIPTION: Steel body, pilot ratio 1:4, range 100-350 bar (1450-5075 psi), standard setting 280 bar (4060 psi) @ 5 l/min (1.32 US gpm)
 TYPE: **VODL/N78/14/G3.p4/ac** CODE: 1553612101
 DESCRIPTION: Steel body, pilot ratio 1:4, range 60-220 bar (870-3190 psi), standard setting 150 bar (2170 psi) @ 5 l/min (1.32 US gpm)
 TYPE: **VODL/N78/S6/G5.p4/ac** CODE: 1553612200
 DESCRIPTION: Steel body, pilot ratio 1:4, range 100-350 bar (1450-5075 psi), standard setting 280 bar (4060 psi) @ 5 l/min (1.32 US gpm)
 TYPE: **VODL/N78/S6/G3.p4/ac** CODE: 1553612201
 DESCRIPTION: Steel body, pilot ratio 1:4, range 60-220 bar (870-3190 psi), standard setting 150 bar (2170 psi) @ 5 l/min (1.32 US gpm)

VODL/N78....PB complete valves

TYPE: **VODL/N78/14PB/G5.p4/ac** CODE: 1553712100
 DESCRIPTION: Steel body, pilot ratio 1:4, range 100-350 bar (1450-5075 psi), standard setting 280 bar (4060 psi) @ 5 l/min (1.32 US gpm)
 TYPE: **VODL/N78/14PB/G3.p4/ac** CODE: 1553712101
 DESCRIPTION: Steel body, pilot ratio 1:4, range 60-220 bar (870-3190 psi), standard setting 150 bar (2170 psi) @ 5 l/min (1.32 US gpm)

1 Pressure setting spring

TYPE	CODE	DESCRIPTION
For 1:4 pilot ratio		
3	3MOL310282	For range 60-220 bar (870-3190 psi) standard setting 150 bar (2170 psi) @ 5 l/min (1.32 US gpm)
5	380113	For range 100-350 bar (1450-5075 psi) standard setting 280 bar (4060 psi) @ 5 l/min (1.32 US gpm)

2 Setting type

TYPE	CODE	DESCRIPTION
G	-	Screw setting
Z	4COP120420	Antitampering cap

Rating diagrams

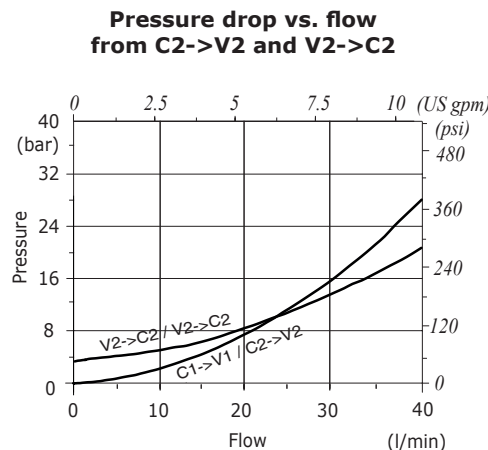

Type VOSL/N1116 - VOSL/R1116 - VOSL/V1116 counterbalance valves



- Single acting
- Load Sensitive (type N)
- Relief compensated (type R)
- Vented (type V)
- Configuration with F1 and F2 flange

Technical specifications and diagrams are measured with mineral oil of 46 cSt viscosity at 40°C (104°F) temperature.

VOSL/N1116 (38-12) - VOSL/R1116 (38-12) - VOSL/V1116 (38-12)

Nominal flow	60 l/min (15.9 US gpm)
Max. pressure	Aluminium body = 210 bar (3050 psi) Steel body = 350 bar (5100 psi)
Oil leakage	0.25 cm ³ /min - 0.015 in ³ /min. (5 drops) at 210 bar - 3050 psi
Fluid	mineral based oil
Viscosity	from 10 to 200 cSt
Max. level of contamination	18/16/13 ISO4406
Fluid temperature	with NBR seals from -20°C (-4°F) to 80°C (176°F)
Environmental temp. for working conditions	from -40°C (-40°F) to 100°C (212°F)

Weight	aluminium	VOSL/N1116/38: 0.59 kg (1.30 lb) - VOSL/N1116/12: 0.75 kg (1.65 lb) VOSL/R1116/38: 0.64 kg (1.41 lb) - VOSL/R1116/12: 0.82 kg (1.81 lb) VOSL/V1116/38: 0.66 kg (1.46 lb) - VOSL/V1116/12: 0.83 kg (1.83 lb)
	steel	VOSL/N1116/38: 1.31 kg (2.88 lb) - VOSL/N1116/12: 1.74 kg (3.84 lb) VOSL/N1116/38PB: - VOSL/N1116/12PB: VOSL/R1116/38: 1.34 kg (2.95 lb) - VOSL/R1116/12: 1.73 kg (3.81 lb) VOSL/V1116/38: 1.36 kg (2.88 lb) - VOSL/V1116/12: 1.78 kg (3.92 lb)

NOTE - For different conditions, please contact Walvoil Sales Dpt.

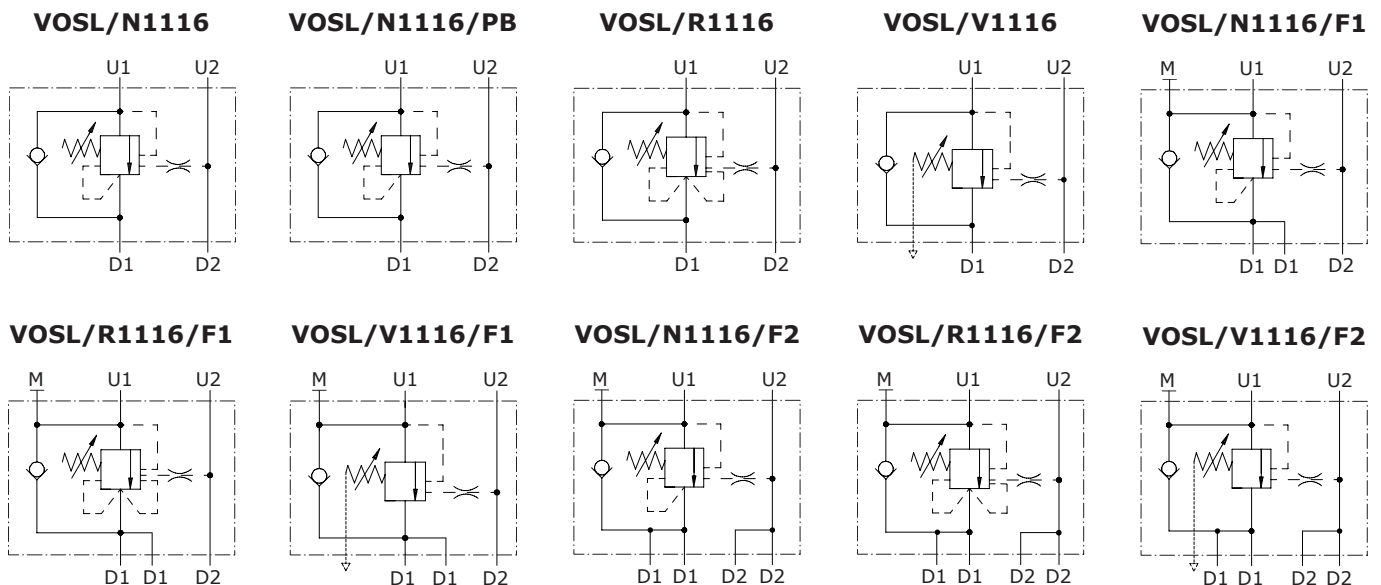

Dimensions

VOSL/...1116/38 - VOSL/...1116/12

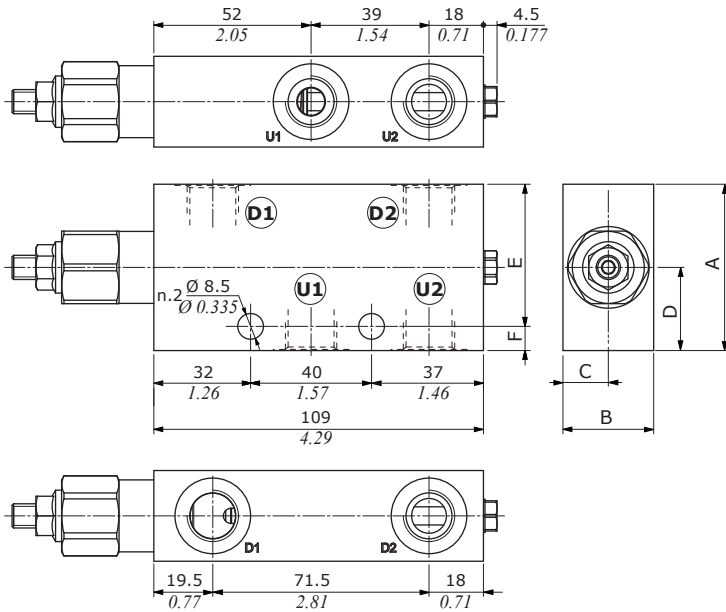

VOSL/...1116/38F1 - VOSL/...1116/12F1

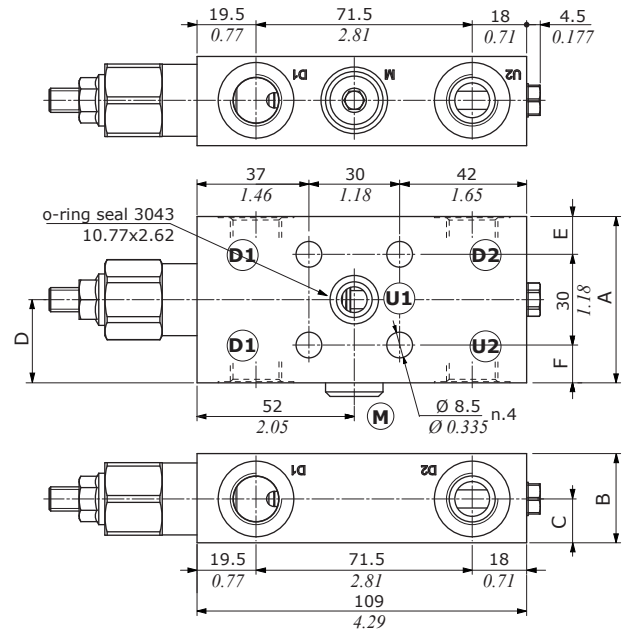

VOSL/N configuration

VOSL/R configuration

VOSL/V configuration

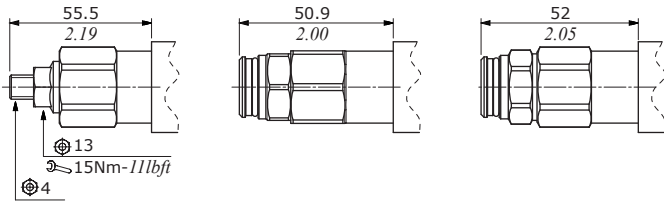

VOSL/...1116/38F2 - VOSL/...1116/12F2

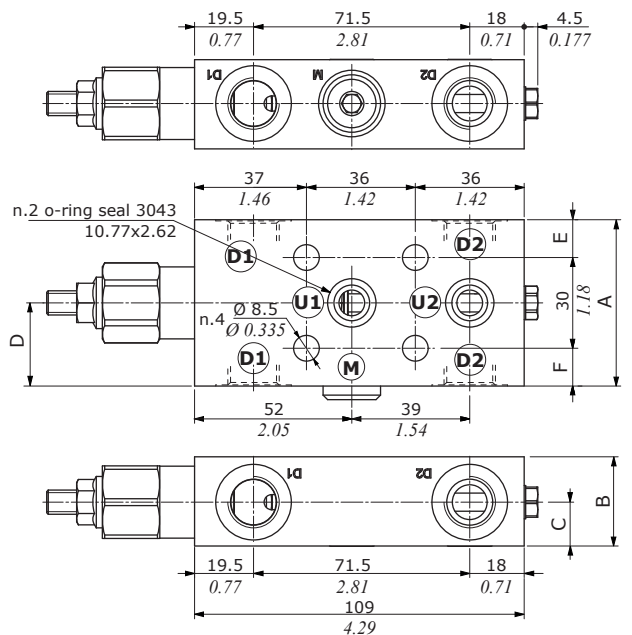

Valve type	D1	D2	U1	U2	M
VOSL/...1116/38	G3/8	G3/8	G3/8	G3/8	-
VOSL/...1116/12	G1/2	G1/2	G1/2	G1/2	-
VOSL/...1116/38F1	G3/8	G3/8	Ø8.5 Ø0.335	G3/8	G1/4
VOSL/...1116/12F1	G1/2	G1/2	Ø8.5 Ø0.335	G1/2	G1/4
VOSL/...1116/38F2	G3/8	G3/8	Ø8.5 Ø0.335	Ø8.5 Ø0.335	G1/4
VOSL/...1116/12F2	G1/2	G1/2	Ø8.5 Ø0.335	Ø8.5 Ø0.335	G1/4

Valve type	D1	D2	U1	U2	M
VOSL/...1116/S8	SAE8	SAE8	SAE8	SAE8	-
VOSL/...1116/S10	SAE10	SAE10	SAE10	SAE10	-
VOSL/...1116/S8F1	SAE8	SAE8	Ø8.5 Ø0.335	SAE8	G1/4
VOSL/...1116/S10F1	SAE10	SAE10	Ø8.5 Ø0.335	SAE10	G1/4
VOSL/...1116/S8F2	SAE8	SAE8	Ø8.5 Ø0.335	Ø8.5 Ø0.335	G1/4
VOSL/...1116/S10F2	SAE10	SAE10	Ø8.5 Ø0.335	Ø8.5 Ø0.335	G1/4

Dimensions are in mm-in

Valve type	A	B	C	D	E	F
VOSL/...1116/38	55	30	15	27.5	47	8
VOSL/...1116/S8	2.17	1.18	0.59	1.08	1.85	0.315
VOSL/...1116/12	65	35	17.5	32.5	57	8
VOSL/...1116/S10	2.26	1.38	0.69	1.28	2.24	0.315
VOSL/...1116/38F1	55	29.5	14.5	27.5	12.5	12.5
VOSL/...1116/S8F1	2.17	1.16	0.57	1.08	0.49	0.49
VOSL/...1116/12F1	65	34.5	17	32.5	17.5	17.5
VOSL/...1116/S10F1	2.26	1.36	0.67	1.28	0.69	0.69
VOSL/...1116/38F2	55	29.5	14.5	27.5	12.5	12.5
VOSL/...1116/S8F2	2.17	1.16	0.57	1.08	0.49	0.49
VOSL/...1116/12F2	65	34.5	17	32.5	17.5	17.5
VOSL/...1116/S10F2	2.26	1.36	0.67	1.28	0.69	0.69

Ordering codes and description composition

VOSL/N1116/38PB - VOSL/N1116/12PB

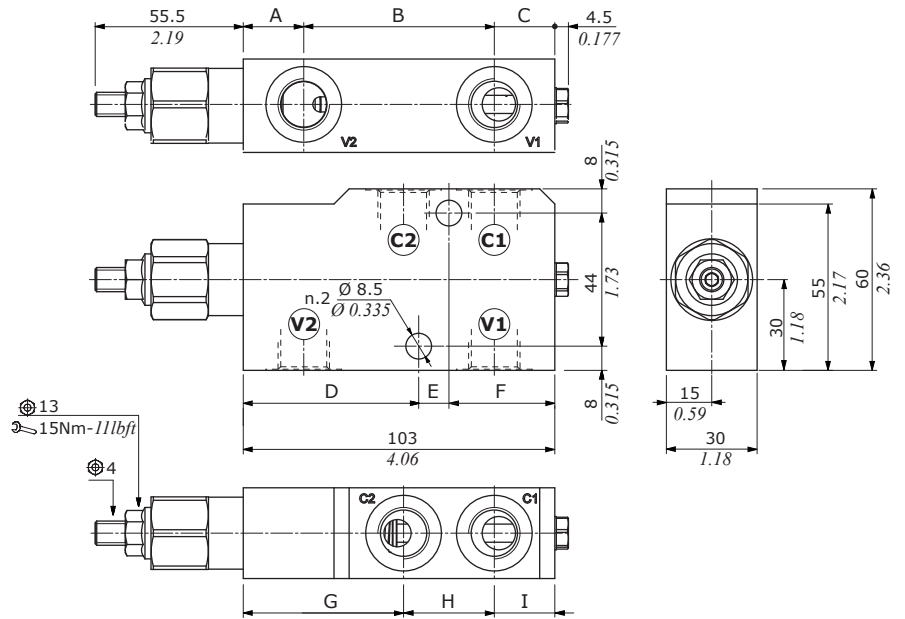

Valve type	All ports
VOSL/N1116/38PB	G3/8
VOSL/N1116/12PB	G1/2

Dimensions are in mm-in

Valve type	A	B	C	D	E	F	G	H	I
VOSL/N1116/38PB	20-0.79	63-2.48	20-0.79	58-2.28	10-0.394	35-1.38	53-2.09	30-1.18	20-0.79
VOSL/N1116/12PB	20-0.79	69-2.72	14-0.55	60.5-2.38	10-0.394	32.5-1.28	53-2.09	36-1.42	14-0.55

Ordering codes and description composition

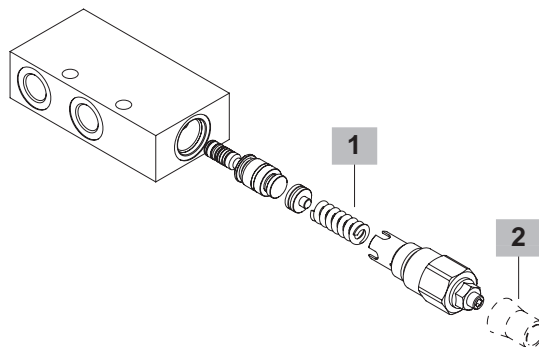
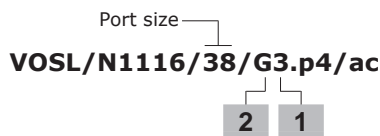

VOSL/N1116 complete valves

Load sensitive (N) configuration with G3/8 thread

Pilot ratio 1:4

TYPE: **VOSL/N1116/38/G3.p4/ac** CODE: 1514322101
DESCRIPTION: Steel body, range 5-210 bar (72.5-3050 psi), std setting 150 bar (2175 psi) @ 5 l/min (1.32 US gpm)

TYPE: **VOSL/N1116/38/G5.p4/ac** CODE: 1514322100
DESCRIPTION: Steel body, range 50-350 bar (725-5075 psi), std setting 280 bar (4060 psi) @ 5 l/min (1.32 US gpm)

TYPE: **VOSL/N1116/38/G5.p4** CODE: 1514321100
DESCRIPTION: Aluminium body, range 50-350 bar (725-5075 psi), std setting 280 bar (4060 psi) @ 5 l/min (1.32 US gpm)

Pilot ratio 1:8

TYPE: **VOSL/N1116/38/G5.p8/ac** CODE: 1514322104
DESCRIPTION: Steel body, range 5-350 bar (72.5-5075 psi), std setting 280 bar (4060 psi) @ 5 l/min (1.32 US gpm)

Zero differential pilot ratio

TYPE: **VOSL/N1116/38/G3.p0/ac** CODE: 1514322106
DESCRIPTION: Steel body, range 5-210 bar (72.5-3050 psi). Std setting 150 bar (2175 psi) @ 5 l/min (1.32 US gpm)

TYPE: **VOSL/N1116/38/G5.p0/ac** CODE: 1514322107
DESCRIPTION: Steel body, range 50-350 bar (725-5075 psi), std setting 280 bar (4060 psi) @ 5 l/min (1.32 US gpm)

Load sensitive (N) configuration with G3/8 thread and F1 flange

TYPE: **VOSL/N1116/38F1/G5.p4/ac** CODE: 1515022100
DESCRIPTION: Steel body, pilot ratio 1:4, range 50-350 bar (725-5075 psi), std setting 280 bar (4060 psi) @ 5 l/min (1.32 US gpm)

TYPE: **VOSL/N1116/38F1/G5.p8/ac** CODE: 1515022101
DESCRIPTION: Steel body, pilot ratio 1:8, range 5-350 bar (72.5-5075 psi), std setting 280 bar (4060 psi) @ 5 l/min (1.32 US gpm)

TYPE: **VOSL/N1116/38F1/G5.p0/ac** CODE: 1515022102
DESCRIPTION: Steel body, zero differential pilot ratio, range 50-350 bar (725-5075 psi), std setting 280 bar (4060 psi) @ 5 l/min (1.32 US gpm)

Load sensitive (N) configuration with G3/8 thread and F2 flange

TYPE: **VOSL/N1116/38F2/G5.p4/ac** CODE: 1515022103
DESCRIPTION: Steel body, pilot ratio 1:4, range 50-350 bar (725-5075 psi), std setting 280 bar (4060 psi) @ 5 l/min (1.32 US gpm)

TYPE: **VOSL/N1116/38F2/G5.p8/ac** CODE: 1515022104
DESCRIPTION: Steel body, pilot ratio 1:8, range 5-350 bar (72.5-5075 psi), std setting 280 bar (4060 psi) @ 5 l/min (1.32 US gpm)

TYPE: **VOSL/N1116/38F2/G5.p0/ac** CODE: 1515022105
DESCRIPTION: Steel body, zero differential pilot ratio, range 50-350 bar (725-5075 psi), std setting 280 bar (4060 psi) @ 5 l/min (1.32 US gpm)

VOSL/N1116 complete valves (continua)

Load sensitive (N) configuration with SAE8 thread

Pilot ratio 1:4

TYPE: **VOSL/N1116/S8/G3.p4/ac** CODE: 1514322200
DESCRIPTION: Steel body, range 5-210 bar (72.5-3050 psi), std setting 150 bar (2175 psi) @ 5 l/min (1.32 US gpm)

TYPE: **VOSL/N1116/S8/G5.p4/ac** CODE: 1514322201
DESCRIPTION: Steel body, range 50-350 bar (725-5075 psi), std setting 280 bar (4060 psi) @ 5 l/min (1.32 US gpm)

TYPE: **VOSL/N1116/S8/G5.p4** CODE: 1514321200
DESCRIPTION: Aluminium body, range 50-350 bar (725-5075 psi), std setting 280 bar (4060 psi) @ 5 l/min (1.32 US gpm)

Pilot ratio 1:8

TYPE: **VOSL/N1116/S8/G5.p8/ac** CODE: 1514322204
DESCRIPTION: Steel body, range 5-350 bar (72.5-5075 psi), std setting 280 bar (4060 psi) @ 5 l/min (1.32 US gpm)

Zero differential pilot ratio

TYPE: **VOSL/N1116/S8/G3.p0/ac** CODE: 1514322206
DESCRIPTION: Steel body, range 5-210 bar (72.5-3050 psi). Std setting 150 bar (2175 psi) @ 5 l/min (1.32 US gpm)

TYPE: **VOSL/N1116/S8/G5.p0/ac** CODE: 1514322207
DESCRIPTION: Steel body, range 50-350 bar (725-5075 psi), std setting 280 bar (4060 psi) @ 5 l/min (1.32 US gpm)

Load sensitive (N) configuration with SAE8 thread and F1 flange

TYPE: **VOSL/N1116/S8F1/G5.p4/ac** CODE: 1515022200
DESCRIPTION: Steel body, pilot ratio 1:4, range 50-350 bar (725-5075 psi), std setting 280 bar (4060 psi) @ 5 l/min (1.32 US gpm)

TYPE: **VOSL/N1116/S8F1/G5.p8/ac** CODE: 1515022201
DESCRIPTION: Steel body, pilot ratio 1:8, range 5-350 bar (72.5-5075 psi), std setting 280 bar (4060 psi) @ 5 l/min (1.32 US gpm)

TYPE: **VOSL/N1116/S8F1/G5.p0/ac** CODE: 1515022202
DESCRIPTION: Steel body, zero differential pilot ratio, range 50-350 bar (725-5075 psi), std setting 280 bar (4060 psi) @ 5 l/min (1.32 US gpm)

Load sensitive (N) configuration with SAE8 thread and F2 flange

TYPE: **VOSL/N1116/S8F2/G5.p4/ac** CODE: 1515022203
DESCRIPTION: Steel body, pilot ratio 1:4, range 50-350 bar (725-5075 psi), std setting 280 bar (4060 psi) @ 5 l/min (1.32 US gpm)

TYPE: **VOSL/N1116/S8F2/G5.p8/ac** CODE: 1515022204
DESCRIPTION: Steel body, pilot ratio 1:8, range 5-350 bar (72.5-5075 psi), std setting 280 bar (4060 psi) @ 5 l/min (1.32 US gpm)

TYPE: **VOSL/N1116/S8F2/G5.p0/ac** CODE: 1515022205
DESCRIPTION: Steel body, zero differential pilot ratio, range 50-350 bar (725-5075 psi), std setting 280 bar (4060 psi) @ 5 l/min (1.32 US gpm)

Ordering codes and description composition

VOSL/N1116 complete valves

Load sensitive (N) configuration with G1/2 thread

TYPE: **VOSL/N1116/12/G5.p4/ac** CODE: 1514332100
DESCRIPTION: Steel body, pilot ratio 1:4, range 50-350 bar (72.5-5075 psi), std setting 280 bar (4060 psi) @ 5 l/min (1.32 US gpm)

TYPE: **VOSL/N1116/12/G5.p8/ac** CODE: 1514332101
DESCRIPTION: Steel body, pilot ratio 1:8, range 5-350 bar (72.5-5075 psi), std setting 280 bar (4060 psi) @ 5 l/min (1.32 US gpm)

TYPE: **VOSL/N1116/12/G5.p0/ac** CODE: 1514332102
DESCRIPTION: Steel body, zero differential pilot ratio, range 50-350 bar (72.5-5075 psi), std setting 280 bar (4060 psi) @ 5 l/min (1.32 US gpm)

TYPE: **VOSL/N1116/12/G5.p4** CODE: 1514331100
DESCRIPTION: Aluminium body, pilot ratio 1:4 range 50-350 bar (72.5-5075 psi), std setting 280 bar (4060 psi) @ 5 l/min (1.32 US gpm)

Load sensitive (N) configuration with G1/2 thread and F1 flange

TYPE: **VOSL/N1116/12F1/G5.p4/ac** CODE: 1515032100
DESCRIPTION: Steel body, pilot ratio 1:4, range 50-350 bar (72.5-5075 psi), std setting 280 bar (4060 psi) @ 5 l/min (1.32 US gpm)

TYPE: **VOSL/N1116/12F1/G5.p8/ac** CODE: 1515032101
DESCRIPTION: Steel body, pilot ratio 1:8, range 5-350 bar (72.5-5075 psi), std setting 280 bar (4060 psi) @ 5 l/min (1.32 US gpm)

TYPE: **VOSL/N1116/12F1/G5.p0/ac** CODE: 1515032102
DESCRIPTION: Steel body, zero differential pilot ratio, range 50-350 bar (72.5-5075 psi), std setting 280 bar (4060 psi) @ 5 l/min (1.32 US gpm)

Load sensitive (N) configuration with G1/2 thread and F1 flange

TYPE: **VOSL/N1116/12F2/G5.p4/ac** CODE: 1515032103
DESCRIPTION: Steel body, pilot ratio 1:4, range 50-350 bar (72.5-5075 psi), std setting 280 bar (4060 psi) @ 5 l/min (1.32 US gpm)

TYPE: **VOSL/N1116/12F2/G5.p8/ac** CODE: 1515032104
DESCRIPTION: Steel body, pilot ratio 1:8. Range 5-350 bar (72.5-5075 psi), std setting 280 bar (4060 psi) @ 5 l/min (1.32 US gpm)

TYPE: **VOSL/N1116/12F2/G5.p0/ac** CODE: 1515032105
DESCRIPTION: Steel body, zero differential pilot ratio, range 50-350 bar (72.5-5075 psi), std setting 280 bar (4060 psi) @ 5 l/min (1.32 US gpm)

For other configurations please contact our Sales Dpt.

VOSL/N1116 complete valves

Load sensitive (N) configuration with SAE10 thread

TYPE: **VOSL/N1116/S10/G5.p4/ac** CODE: 1514332200
DESCRIPTION: Steel body, pilot ratio 1:4, range 50-350 bar (72.5-5075 psi), std setting 280 bar (4060 psi) @ 5 l/min (1.32 US gpm)

TYPE: **VOSL/N1116/S10/G5.p8/ac** CODE: 1514332201
DESCRIPTION: Steel body, pilot ratio 1:8, range 5-350 bar (72.5-5075 psi), std setting 280 bar (4060 psi) @ 5 l/min (1.32 US gpm)

TYPE: **VOSL/N1116/S10/G5.p0/ac** CODE: 1514332202
DESCRIPTION: Steel body, zero differential pilot ratio, range 50-350 bar (72.5-5075 psi), std setting 280 bar (4060 psi) @ 5 l/min (1.32 US gpm)

Load sensitive (N) configuration with SAE10 thread and F1 flange

TYPE: **VOSL/N1116/S10F1/G5.p4/ac** CODE: 1515032200
DESCRIPTION: Steel body, pilot ratio 1:4, range 50-350 bar (72.5-5075 psi), std setting 280 bar (4060 psi) @ 5 l/min (1.32 US gpm)

TYPE: **VOSL/N1116/S10F1/G5.p8/ac** CODE: 1515032201
DESCRIPTION: Steel body, pilot ratio 1:8, range 5-350 bar (72.5-5075 psi), std setting 280 bar (4060 psi) @ 5 l/min (1.32 US gpm)

TYPE: **VOSL/N1116/S10F1/G5.p0/ac** CODE: 1515032202
DESCRIPTION: Steel body, zero differential pilot ratio, range 50-350 bar (72.5-5075 psi), std setting 280 bar (4060 psi) @ 5 l/min (1.32 US gpm)

Load sensitive (N) configuration with SAE10 thread and F2 flange

TYPE: **VOSL/N1116/S10F2/G5.p4/ac** CODE: 1515032203
DESCRIPTION: Steel body, pilot ratio 1:4, range 50-350 bar (72.5-5075 psi), std setting 280 bar (4060 psi) @ 5 l/min (1.32 US gpm)

TYPE: **VOSL/N1116/S10F2/G5.p8/ac** CODE: 1515032204
DESCRIPTION: Steel body, pilot ratio 1:8. Range 5-350 bar (72.5-5075 psi), std setting 280 bar (4060 psi) @ 5 l/min (1.32 US gpm)

TYPE: **VOSL/N1116/S10F2/G5.p0/ac** CODE: 1515032205
DESCRIPTION: Steel body, zero differential pilot ratio, range 50-350 bar (72.5-5075 psi), std setting 280 bar (4060 psi) @ 5 l/min (1.32 US gpm)

For other configurations please contact our Sales Dpt.

1 Pressure setting spring

TYPE	CODE	DESCRIPTION
------	------	-------------

For 1:4 and zero differential pilot ratio

3	3ML1133201	For range 5-210 bar (72.5-3050 psi)
5	3ML1133200	For range 50-350 bar (72.5-5075 psi)

For 1:8 pilot ratio

5	3ML1133201	For range 5-350 bar (72.5-5075 psi)
----------	------------	-------------------------------------

2 Setting type

TYPE	CODE	DESCRIPTION
------	------	-------------

G	-	Screw setting
Z	4COP120420	Antitampering cap

Ordering codes and description composition

Port size
VOSL/R1116/38/G3.p4/ac

2 1

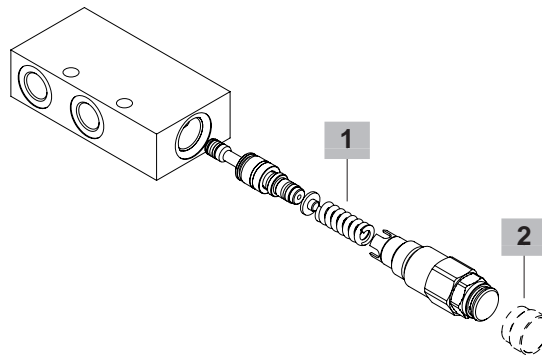

VOSL/R1116 complete valves

Relief compensated (R) configuration with G3/8 thread

Pilot ratio 1:4

TYPE: **VOSL/R1116/38/G3.p4/ac** CODE: 1514422101
DESCRIPTION: Steel body, range 5-210 bar (72.5-3050 psi), std setting 150 bar (2175 psi) @ 5 l/min (1.32 US gpm)

TYPE: **VOSL/R1116/38/G5.p4/ac** CODE: 1514422100
DESCRIPTION: Steel body, range 50-350 bar (725-5075 psi), std setting 280 bar (4060 psi) @ 5 l/min (1.32 US gpm)

TYPE: **VOSL/R1116/38/G5.p4** CODE: 1514421100
DESCRIPTION: Aluminium body, range 50-350 bar (725-5075 psi), std setting 280 bar (4060 psi) @ 5 l/min (1.32 US gpm)

Pilot ratio 1:8

TYPE: **VOSL/R1116/38/G5.p8/ac** CODE: 1514422104
DESCRIPTION: Steel body, range 5-350 bar (72.5-5075 psi), std setting 280 bar (4060 psi) @ 5 l/min (1.32 US gpm)

Zero differential pilot ratio

TYPE: **VOSL/R1116/38/G3.p0/ac** CODE: 1514422106
DESCRIPTION: Steel body, range 5-210 bar (72.5-3050 psi), std setting 150 bar (2175 psi) @ 5 l/min (1.32 US gpm)

TYPE: **VOSL/R1116/38/G5.p0/ac** CODE: 1514422107
DESCRIPTION: Steel body, range 50-350 bar (725-5075 psi), std setting 280 bar (4060 psi) @ 5 l/min (1.32 US gpm)

Relief compensated (R) configuration with G3/8 thread and F1 flange
TYPE: **VOSL/R1116/38F1/G5.p4/ac** CODE: 1515122100
DESCRIPTION: Steel body, pilot ratio 1:4, range 50-350 bar (725-5075 psi), std setting 280 bar (4060 psi) @ 5 l/min (1.32 US gpm)

TYPE: **VOSL/R1116/38F1/G5.p8/ac** CODE: 1515122101
DESCRIPTION: Steel body, pilot ratio 1:8, range 5-350 bar (72.5-5075 psi), std setting 280 bar (4060 psi) @ 5 l/min (1.32 US gpm)

TYPE: **VOSL/R1116/38F1/G5.p0/ac** CODE: 1515122102
DESCRIPTION: Steel body, zero differential pilot ratio, range 50-350 bar (725-5075 psi), std setting 280 bar (4060 psi) @ 5 l/min (1.32 US gpm)

Relief compensated (R) configuration with G3/8 thread and F2 flange
TYPE: **VOSL/R1116/38F2/G5.p4/ac** CODE: 1515122103
DESCRIPTION: Steel body, pilot ratio 1:4, range 50-350 bar (725-5075 psi), std setting 280 bar (4060 psi) @ 5 l/min (1.32 US gpm)

TYPE: **VOSL/R1116/38F2/G5.p8/ac** CODE: 1515122104
DESCRIPTION: Steel body, pilot ratio 1:8, range 5-350 bar (72.5-5075 psi), std setting 280 bar (4060 psi) @ 5 l/min (1.32 US gpm)

TYPE: **VOSL/R1116/38F2/G5.p0/ac** CODE: 1515122105
DESCRIPTION: Steel body, zero differential pilot ratio, range 50-350 bar (725-5075 psi), std setting 280 bar (4060 psi) @ 5 l/min (1.32 US gpm)

VOSL/R1116 complete valves

Relief compensated (R) configuration with SAE8 thread

Pilot ratio 1:4

TYPE: **VOSL/R1116/S8/G3.p4/ac** CODE: 1514422200
DESCRIPTION: Steel body, range 5-210 bar (72.5-3050 psi), std setting 150 bar (2175 psi) @ 5 l/min (1.32 US gpm)

TYPE: **VOSL/R1116/S8/G5.p4/ac** CODE: 1514422201
DESCRIPTION: Steel body, range 50-350 bar (725-5075 psi), std setting 280 bar (4060 psi) @ 5 l/min (1.32 US gpm)

Pilot ratio 1:8

TYPE: **VOSL/R1116/S8/G5.p8/ac** CODE: 1514422204
DESCRIPTION: Steel body, range 5-350 bar (72.5-5075 psi), std setting 280 bar (4060 psi) @ 5 l/min (1.32 US gpm)

Zero differential pilot ratio

TYPE: **VOSL/R1116/S8/G3.p0/ac** CODE: 1514422206
DESCRIPTION: Steel body, range 5-210 bar (72.5-3050 psi), std setting 150 bar (2175 psi) @ 5 l/min (1.32 US gpm)

TYPE: **VOSL/R1116/S8/G5.p0/ac** CODE: 1514422207
DESCRIPTION: Steel body, range 50-350 bar (725-5075 psi), std setting 280 bar (4060 psi) @ 5 l/min (1.32 US gpm)

Relief compensated (R) configuration with SAE8 thread and F1 flange
TYPE: **VOSL/R1116/S8F1/G5.p4/ac** CODE: 1515122200
DESCRIPTION: Steel body, pilot ratio 1:4, range 50-350 bar (725-5075 psi), std setting 280 bar (4060 psi) @ 5 l/min (1.32 US gpm)

TYPE: **VOSL/R1116/S8F1/G5.p8/ac** CODE: 1515122201
DESCRIPTION: Steel body, pilot ratio 1:8, range 5-350 bar (72.5-5075 psi), std setting 280 bar (4060 psi) @ 5 l/min (1.32 US gpm)

TYPE: **VOSL/R1116/S8F1/G5.p0/ac** CODE: 1515122202
DESCRIPTION: Steel body, zero differential pilot ratio, range 50-350 bar (725-5075 psi), std setting 280 bar (4060 psi) @ 5 l/min (1.32 US gpm)

Relief compensated (R) configuration with SAE8 thread and F2 flange
TYPE: **VOSL/R1116/S8F2/G5.p4/ac** CODE: 1515122203
DESCRIPTION: Steel body, pilot ratio 1:4, range 50-350 bar (725-5075 psi), std setting 280 bar (4060 psi) @ 5 l/min (1.32 US gpm)

TYPE: **VOSL/R1116/S8F2/G5.p8/ac** CODE: 1515122204
DESCRIPTION: Steel body, pilot ratio 1:8, range 5-350 bar (72.5-5075 psi), std setting 280 bar (4060 psi) @ 5 l/min (1.32 US gpm)

TYPE: **VOSL/R1116/S8F2/G5.p0/ac** CODE: 1515122205
DESCRIPTION: Steel body, zero differential pilot ratio, range 50-350 bar (725-5075 psi), std setting 280 bar (4060 psi) @ 5 l/min (1.32 US gpm)

Ordering codes and description composition

VOSL/R1116 complete valves

Relief compensated (R) configuration with G1/2 thread

TYPE: **VOSL/R1116/12/G5.p4/ac** CODE: 1514432100
DESCRIPTION: Steel body, pilot ratio 1:4, range 50-350 bar (72.5-5075 psi), std setting 280 bar (4060 psi) @ 5 l/min (1.32 US gpm)

TYPE: **VOSL/R1116/12/G5.p8/ac** CODE: 1514432101
DESCRIPTION: Steel body, pilot ratio 1:8, range 5-350 bar (72.5-5075 psi), std setting 280 bar (4060 psi) @ 5 l/min (1.32 US gpm)

TYPE: **VOSL/R1116/12/G5.p0/ac** CODE: 1514432102
DESCRIPTION: Steel body, zero differential pilot ratio, range 50-350 bar (72.5-5075 psi), std setting 280 bar (4060 psi) @ 5 l/min (1.32 US gpm)

TYPE: **VOSL/R1116/12/G5.p4** CODE: 1514431100
DESCRIPTION: Aluminium body, pilot ratio 1:4, range 50-350 bar (72.5-5075 psi), std setting 280 bar (4060 psi) @ 5 l/min (1.32 US gpm)

Relief compensated (R) configuration with G1/2 thread and F1 flange

TYPE: **VOSL/R1116/12F1/G5.p4/ac** CODE: 1515132100
DESCRIPTION: Steel body, pilot ratio 1:4, range 50-350 bar (72.5-5075 psi), std setting 280 bar (4060 psi) @ 5 l/min (1.32 US gpm)

TYPE: **VOSL/R1116/12F1/G5.p8/ac** CODE: 1515132101
DESCRIPTION: Steel body, pilot ratio 1:8, range 5-350 bar (72.5-5075 psi), std setting 280 bar (4060 psi) @ 5 l/min (1.32 US gpm)

TYPE: **VOSL/R1116/12F1/G5.p0/ac** CODE: 1515132102
DESCRIPTION: Steel body, zero differential pilot ratio, range 50-350 bar (72.5-5075 psi), std setting 280 bar (4060 psi) @ 5 l/min (1.32 US gpm)

Relief compensated (R) configuration with G1/2 thread and F2 flange

TYPE: **VOSL/R1116/12F2/G5.p4/ac** CODE: 1515132103
DESCRIPTION: Steel body, pilot ratio 1:4, range 50-350 bar (72.5-5075 psi), std setting 280 bar (4060 psi) @ 5 l/min (1.32 US gpm)

TYPE: **VOSL/R1116/12F2/G5.p8/ac** CODE: 1515132104
DESCRIPTION: Steel body, pilot ratio 1:8, range 5-350 bar (72.5-5075 psi), std setting 280 bar (4060 psi) @ 5 l/min (1.32 US gpm)

TYPE: **VOSL/R1116/12F2/G5.p0/ac** CODE: 1515132105
DESCRIPTION: Steel body, zero differential pilot ratio, range 50-350 bar (72.5-5075 psi), std setting 280 bar (4060 psi) @ 5 l/min (1.32 US gpm)

For other configurations please contact our Sales Dpt.

VOSL/R1116 complete valves

Relief compensated (R) configuration with SAE10 thread

TYPE: **VOSL/R1116/S10/G5.p4/ac** CODE: 1514432200
DESCRIPTION: Steel body, pilot ratio 1:4, range 50-350 bar (72.5-5075 psi), std setting 280 bar (4060 psi) @ 5 l/min (1.32 US gpm)

TYPE: **VOSL/R1116/S10/G5.p8/ac** CODE: 1514432201
DESCRIPTION: Steel body, pilot ratio 1:8, range 5-350 bar (72.5-5075 psi), std setting 280 bar (4060 psi) @ 5 l/min (1.32 US gpm)

TYPE: **VOSL/R1116/S10/G5.p0/ac** CODE: 1514432202
DESCRIPTION: Steel body, zero differential pilot ratio, range 50-350 bar (72.5-5075 psi), std setting 280 bar (4060 psi) @ 5 l/min (1.32 US gpm)

TYPE: **VOSL/R1116/S10/G5.p4** CODE: 1514431200
DESCRIPTION: Aluminium body, pilot ratio 1:4, range 50-350 bar (72.5-5075 psi), std setting 280 bar (4060 psi) @ 5 l/min (1.32 US gpm)

Relief compensated (R) configuration with SAE10 thread and F1 flange

TYPE: **VOSL/R1116/S10F1/G5.p4/ac** CODE: 1515132200
DESCRIPTION: Steel body, pilot ratio 1:4, range 50-350 bar (72.5-5075 psi), std setting 280 bar (4060 psi) @ 5 l/min (1.32 US gpm)

TYPE: **VOSL/R1116/S10F1/G5.p8/ac** CODE: 1515132201
DESCRIPTION: Steel body, pilot ratio 1:8, range 5-350 bar (72.5-5075 psi), std setting 280 bar (4060 psi) @ 5 l/min (1.32 US gpm)

TYPE: **VOSL/R1116/S10F1/G5.p0/ac** CODE: 1515132202
DESCRIPTION: Steel body, zero differential pilot ratio, range 50-350 bar (72.5-5075 psi), std setting 280 bar (4060 psi) @ 5 l/min (1.32 US gpm)

Relief compensated (R) configuration with SAE10 thread and F2 flange

TYPE: **VOSL/R1116/S10F2/G5.p4/ac** CODE: 1515132203
DESCRIPTION: Steel body, pilot ratio 1:4, range 50-350 bar (72.5-5075 psi), std setting 280 bar (4060 psi) @ 5 l/min (1.32 US gpm)

TYPE: **VOSL/R1116/S10F2/G5.p8/ac** CODE: 1515132204
DESCRIPTION: Steel body, pilot ratio 1:8, range 5-350 bar (72.5-5075 psi), std setting 280 bar (4060 psi) @ 5 l/min (1.32 US gpm)

TYPE: **VOSL/R1116/S10F2/G5.p0/ac** CODE: 1515132205
DESCRIPTION: Steel body, zero differential pilot ratio, range 50-350 bar (72.5-5075 psi), std setting 280 bar (4060 psi) @ 5 l/min (1.32 US gpm)

For other configurations please contact our Sales Dpt.

1 Pressure setting spring

TYPE	CODE	DESCRIPTION
------	------	-------------

For 1:4 and zero differential pilot ratio

3	3ML1133201	For range 5-210 bar (72.5-3050 psi)
----------	------------	-------------------------------------

5	3ML1133200	For range 50-350 bar (72.5-5075 psi)
----------	------------	--------------------------------------

For 1:8 pilot ratio

5	3ML1133201	For range 5-350 bar (72.5-5075 psi)
----------	------------	-------------------------------------

2 Setting type

TYPE	CODE	DESCRIPTION
------	------	-------------

G	-	Screw setting
----------	---	---------------

Z	4COP130200	Antitampering cap
----------	------------	-------------------

Ordering codes and description composition

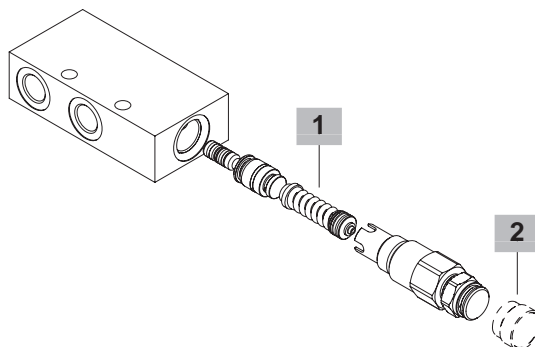
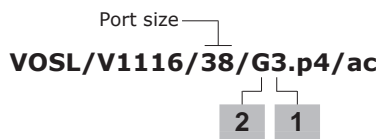

VOSL/V1116 complete valves

Vented (V) configuration with G3/8 thread

Pilot ratio 1:4

TYPE: **VOSL/V1116/38/G3.p4/ac** CODE: 1514522101
DESCRIPTION: Steel body, range 5-210 bar (72.5-3050 psi), std setting 150 bar (2175 psi) @ 5 l/min (1.32 US gpm)

TYPE: **VOSL/V1116/38/G5.p4/ac** CODE: 1514522100
DESCRIPTION: Steel body, range 50-350 bar (725-5075 psi), std setting 280 bar (4060 psi) @ 5 l/min (1.32 US gpm)

TYPE: **VOSL/V1116/38/G5.p4** CODE: 1514521100
DESCRIPTION: Aluminium body, range 50-350 bar (725-5075 psi), std setting 280 bar (4060 psi) @ 5 l/min (1.32 US gpm)

Pilot ratio 1:8

TYPE: **VOSL/V1116/38/G5.p8/ac** CODE: 1514522104
DESCRIPTION: Steel body, range 5-350 bar (72.5-5075 psi), std setting 280 bar (4060 psi) @ 5 l/min (1.32 US gpm)

Zero differential pilot ratio

TYPE: **VOSL/V1116/38/G3.p0/ac** CODE: 1514522106
DESCRIPTION: Steel body, range 5-210 bar (72.5-3050 psi), std setting 150 bar (2175 psi) @ 5 l/min (1.32 US gpm)

TYPE: **VOSL/V1116/38/G5.p0/ac** CODE: 1514522107
DESCRIPTION: Steel body, range 50-350 bar (725-5075 psi), std setting 280 bar (4060 psi) @ 5 l/min (1.32 US gpm)

Vented (V) configuration with G3/8 thread and F1 flange

TYPE: **VOSL/V1116/38F1/G5.p4/ac** CODE: 1515222100
DESCRIPTION: Steel body, pilot ratio 1:4, range 50-350 bar (725-5075 psi), std setting 280 bar (4060 psi) @ 5 l/min (1.32 US gpm)

TYPE: **VOSL/V1116/38F1/G5.p8/ac** CODE: 1515222101
DESCRIPTION: Steel body, pilot ratio 1:8, range 5-350 bar (72.5-5075 psi), std setting 280 bar (4060 psi) @ 5 l/min (1.32 US gpm)

TYPE: **VOSL/V1116/38F1/G5.p0/ac** CODE: 1515222102
DESCRIPTION: Steel body, zero differential pilot ratio, range 50-350 bar (725-5075 psi), std setting 280 bar (4060 psi) @ 5 l/min (1.32 US gpm)

Vented (V) configuration with G3/8 thread and F2 flange

TYPE: **VOSL/V1116/38F2/G5.p4/ac** CODE: 1515222103
DESCRIPTION: Steel body, pilot ratio 1:4, range 50-350 bar (725-5075 psi), std setting 280 bar (4060 psi) @ 5 l/min (1.32 US gpm)

TYPE: **VOSL/V1116/38F2/G5.p8/ac** CODE: 1515222104
DESCRIPTION: Steel body, pilot ratio 1:8, range 5-350 bar (72.5-5075 psi), std setting 280 bar (4060 psi) @ 5 l/min (1.32 US gpm)

TYPE: **VOSL/V1116/38F2/G5.p0/ac** CODE: 1515222105
DESCRIPTION: Steel body, zero differential pilot ratio, range 50-350 bar (725-5075 psi), std setting 280 bar (4060 psi) @ 5 l/min (1.32 US gpm)

VOSL/V1116 complete valves

Vented (V) configuration with SAE8 thread

Pilot ratio 1:4

TYPE: **VOSL/V1116/S8/G3.p4/ac** CODE: 1514522200
DESCRIPTION: Steel body, range 5-210 bar (72.5-3050 psi), std setting 150 bar (2175 psi) @ 5 l/min (1.32 US gpm)

TYPE: **VOSL/V1116/S8/G5.p4/ac** CODE: 1514522201
DESCRIPTION: Steel body, range 50-350 bar (725-5075 psi), std setting 280 bar (4060 psi) @ 5 l/min (1.32 US gpm)

Pilot ratio 1:8

TYPE: **VOSL/V1116/S8/G5.p8/ac** CODE: 1514522204
DESCRIPTION: Steel body, range 5-350 bar (72.5-5075 psi), std setting 280 bar (4060 psi) @ 5 l/min (1.32 US gpm)

Zero differential pilot ratio

TYPE: **VOSL/V1116/S8/G3.p0/ac** CODE: 1514522206
DESCRIPTION: Steel body, range 5-210 bar (72.5-3050 psi), std setting 150 bar (2175 psi) @ 5 l/min (1.32 US gpm)

TYPE: **VOSL/V1116/S8/G5.p0/ac** CODE: 1514522207
DESCRIPTION: Steel body, range 50-350 bar (725-5075 psi), std setting 280 bar (4060 psi) @ 5 l/min (1.32 US gpm)

Vented (V) configuration with SAE8 thread and F1 flange

TYPE: **VOSL/V1116/S8F1/G5.p4/ac** CODE: 1515222200
DESCRIPTION: Steel body, pilot ratio 1:4, range 50-350 bar (725-5075 psi), std setting 280 bar (4060 psi) @ 5 l/min (1.32 US gpm)

TYPE: **VOSL/V1116/S8F1/G5.p8/ac** CODE: 1515222201
DESCRIPTION: Steel body, pilot ratio 1:8, range 5-350 bar (72.5-5075 psi), std setting 280 bar (4060 psi) @ 5 l/min (1.32 US gpm)

TYPE: **VOSL/V1116/S8F1/G5.p0/ac** CODE: 1515222202
DESCRIPTION: Steel body, zero differential pilot ratio, range 50-350 bar (725-5075 psi), std setting 280 bar (4060 psi) @ 5 l/min (1.32 US gpm)

Vented (V) configuration with SAE8 thread and F2 flange

TYPE: **VOSL/V1116/S8F2/G5.p4/ac** CODE: 1515222203
DESCRIPTION: Steel body, pilot ratio 1:4, range 50-350 bar (725-5075 psi), std setting 280 bar (4060 psi) @ 5 l/min (1.32 US gpm)

TYPE: **VOSL/V1116/S8F2/G5.p8/ac** CODE: 1515222204
DESCRIPTION: Steel body, pilot ratio 1:8, range 5-350 bar (72.5-5075 psi), std setting 280 bar (4060 psi) @ 5 l/min (1.32 US gpm)

TYPE: **VOSL/V1116/S8F2/G5.p0/ac** CODE: 1515222205
DESCRIPTION: Steel body, zero differential pilot ratio, range 50-350 bar (725-5075 psi), std setting 280 bar (4060 psi) @ 5 l/min (1.32 US gpm)

Ordering codes and description composition

VOSL/V1116 complete valves

Vented (V) configuration with G1/2 thread

TYPE: **VOSL/V1116/12/G5.p4/ac** CODE: 1514532100
DESCRIPTION: Steel body, pilot ratio 1:4, range 50-350 bar (72.5-5075 psi), std setting 280 bar (4060 psi) @ 5 l/min (1.32 US gpm)

TYPE: **VOSL/V1116/12/G5.p8/ac** CODE: 1514532101
DESCRIPTION: Steel body, pilot ratio 1:8, range 5-350 bar (72.5-5075 psi), std setting 280 bar (4060 psi) @ 5 l/min (1.32 US gpm)

TYPE: **VOSL/V1116/12/G5.p0/ac** CODE: 1514532102
DESCRIPTION: Steel body, zero differential pilot ratio, range 50-350 bar (72.5-5075 psi), std setting 280 bar (4060 psi) @ 5 l/min (1.32 US gpm)

TYPE: **VOSL/V1116/12/G5.p4** CODE: 1514531100
DESCRIPTION: Aluminium body pilot ratio 1:4, range 50-350 bar (72.5-5075 psi), std setting 280 bar (4060 psi) @ 5 l/min (1.32 US gpm)

Vented (V) configuration with G1/2 thread and F1 flange

TYPE: **VOSL/V1116/12F1/G5.p4/ac** CODE: 1515232100
DESCRIPTION: Steel body, pilot ratio 1:4, range 50-350 bar (72.5-5075 psi), std setting 280 bar (4060 psi) @ 5 l/min (1.32 US gpm)

TYPE: **VOSL/V1116/12F1/G5.p8/ac** CODE: 1515232101
DESCRIPTION: Steel body, pilot ratio 1:8, range 5-350 bar (72.5-5075 psi), std setting 280 bar (4060 psi) @ 5 l/min (1.32 US gpm)

TYPE: **VOSL/V1116/12F1/G5.p0/ac** CODE: 1515232102
DESCRIPTION: Steel body, zero differential pilot ratio, range 50-350 bar (72.5-5075 psi), std setting 280 bar (4060 psi) @ 5 l/min (1.32 US gpm)

Vented (V) configuration with G1/2 thread and F2 flange

TYPE: **VOSL/V1116/12F2/G5.p4/ac** CODE: 1515232103
DESCRIPTION: Steel body, pilot ratio 1:4, range 50-350 bar (72.5-5075 psi), std setting 280 bar (4060 psi) @ 5 l/min (1.32 US gpm)

TYPE: **VOSL/V1116/12F2/G5.p8/ac** CODE: 1515232104
DESCRIPTION: Steel body, pilot ratio 1:8, range 5-350 bar (72.5-5075 psi), std setting 280 bar (4060 psi) @ 5 l/min (1.32 US gpm)

TYPE: **VOSL/V1116/12F2/G5.p0/ac** CODE: 1515232105
DESCRIPTION: Steel body, zero differential pilot ratio, range 50-350 bar (72.5-5075 psi), std setting 280 bar (4060 psi) @ 5 l/min (1.32 US gpm)

For other configurations please contact our Sales Dpt.

VOSL/V1116 complete valves

Vented (V) configuration with SAE10 thread

TYPE: **VOSL/V1116/S10/G5.p4/ac** CODE: 1514532200
DESCRIPTION: Steel body, pilot ratio 1:4, range 50-350 bar (72.5-5075 psi), std setting 280 bar (4060 psi) @ 5 l/min (1.32 US gpm)

TYPE: **VOSL/V1116/S10/G5.p8/ac** CODE: 1514532201
DESCRIPTION: Steel body, pilot ratio 1:8, range 5-350 bar (72.5-5075 psi), std setting 280 bar (4060 psi) @ 5 l/min (1.32 US gpm)

TYPE: **VOSL/V1116/S10/G5.p0/ac** CODE: 1514532202
DESCRIPTION: Steel body, zero differential pilot ratio, range 50-350 bar (72.5-5075 psi), std setting 280 bar (4060 psi) @ 5 l/min (1.32 US gpm)

Vented (V) configuration with SAE10 thread and F1 flange

TYPE: **VOSL/V1116/S10F1/G5.p4/ac** CODE: 1515232200
DESCRIPTION: Steel body, pilot ratio 1:4, range 50-350 bar (72.5-5075 psi), std setting 280 bar (4060 psi) @ 5 l/min (1.32 US gpm)

TYPE: **VOSL/V1116/S10F1/G5.p8/ac** CODE: 1515232201
DESCRIPTION: Steel body, pilot ratio 1:8, range 5-350 bar (72.5-5075 psi), std setting 280 bar (4060 psi) @ 5 l/min (1.32 US gpm)

TYPE: **VOSL/V1116/S10F1/G5.p0/ac** CODE: 1515232202
DESCRIPTION: Steel body, zero differential pilot ratio, range 50-350 bar (72.5-5075 psi), std setting 280 bar (4060 psi) @ 5 l/min (1.32 US gpm)

Vented (V) configuration with SAE10 thread and F2 flange

TYPE: **VOSL/V1116/S10F2/G5.p4/ac** CODE: 1515232203
DESCRIPTION: Steel body, pilot ratio 1:4, range 50-350 bar (72.5-5075 psi), std setting 280 bar (4060 psi) @ 5 l/min (1.32 US gpm)

TYPE: **VOSL/V1116/S10F2/G5.p8/ac** CODE: 1515232204
DESCRIPTION: Steel body, pilot ratio 1:8, range 5-350 bar (72.5-5075 psi), std setting 280 bar (4060 psi) @ 5 l/min (1.32 US gpm)

TYPE: **VOSL/V1116/S10F2/G5.p0/ac** CODE: 1515232205
DESCRIPTION: Steel body, zero differential pilot ratio, range 50-350 bar (72.5-5075 psi), std setting 280 bar (4060 psi) @ 5 l/min (1.32 US gpm)

For other configurations please contact our Sales Dpt.

1 Pressure setting spring

TYPE	CODE	DESCRIPTION
<u>For 1:4 and zero differential pilot ratio</u>		
3	3ML1133201	For range 5-210 bar (72.5-3050 psi)
5	3ML1133200	For range 50-350 bar (72.5-5075 psi)
<u>For 1:8 pilot ratio</u>		
5	3ML1133201	For range 5-350 bar (72.5-5075 psi)

2 Setting type

TYPE	CODE	DESCRIPTION
G	-	Screw setting
Z	4COP130200	Antitampering cap

Ordering codes and description composition

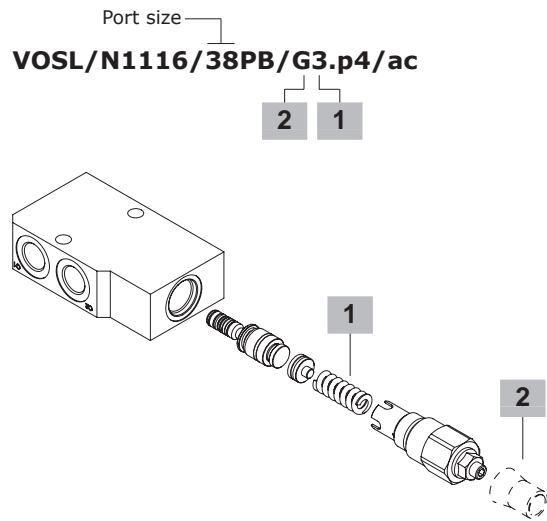

1 Pressure setting spring

TYPE	CODE	DESCRIPTION
For 1:4 and zero differential pilot ratio		
3	3ML1133201	For range 5-210 bar (72.5-3050 psi)
5	3ML1133200	For range 50-350 bar (725-5075 psi)
For 1:8 pilot ratio		
5	3ML1133201	For range 5-350 bar (72.5-5075 psi)

2 Setting type

TYPE	CODE	DESCRIPTION
G	-	Screw setting
Z	4COP130200	Antitampering cap

VOSL/N1116/PB complete valves

Load sensitive (N) configuration with G3/8 thread

Pilot ratio 1:4

TYPE: **VOSL/N1116/38PB/G3.p4/ac** CODE: 1554222101
DESCRIPTION: Steel body, range 5-210 bar (72.5-3050 psi), std setting 150 bar (2175 psi) @ 5 l/min (1.32 US gpm)

TYPE: **VOSL/N1116/38PB/G5.p4/ac** CODE: 1514222100
DESCRIPTION: Steel body, range 50-350 bar (725-5075 psi), std setting 280 bar (4060 psi) @ 5 l/min (1.32 US gpm)

Pilot ratio 1:8

TYPE: **VOSL/N1116/38PB/G5.p8/ac** CODE: 1514222102
DESCRIPTION: Steel body, range 5-350 bar (72.5-5075 psi), std setting 280 bar (4060 psi) @ 5 l/min (1.32 US gpm)

Zero differential pilot ratio

TYPE: **VOSL/N1116/38PB/G5.p0/ac** CODE: 1514222103
DESCRIPTION: Steel body, range 50-350 bar (725-5075 psi), std setting 280 bar (4060 psi) @ 5 l/min (1.32 US gpm)

Load sensitive (N) configuration with G1/2 thread

Pilot ratio 1:4

TYPE: **VOSL/N1116/12PB/G3.p4/ac** CODE: 1514232101
DESCRIPTION: Steel body, range 5-210 bar (72.5-3050 psi), std setting 150 bar (2175 psi) @ 5 l/min (1.32 US gpm)

TYPE: **VOSL/N1116/12PB/G5.p4/ac** CODE: 1514232100
DESCRIPTION: Steel body, range 50-350 bar (725-5075 psi), std setting 280 bar (4060 psi) @ 5 l/min (1.32 US gpm)

Pilot ratio 1:8

TYPE: **VOSL/N1116/12PB/G5.p8/ac** CODE: 1514232102
DESCRIPTION: Steel body, range 5-350 bar (72.5-5075 psi), std setting 280 bar (4060 psi) @ 5 l/min (1.32 US gpm)

Zero differential pilot ratio

TYPE: **VOSL/N1116/12PB/G5.p0/ac** CODE: 1514232103
DESCRIPTION: Steel body, range 50-350 bar (725-5075 psi), std setting 280 bar (4060 psi) @ 5 l/min (1.32 US gpm)

For other configurations please contact our Sales Dpt.

Ordering codes and description composition

VOSL/(N-R-V) 1116 (38-12) pressure drop vs. flow from D1->U1 and U1->D1

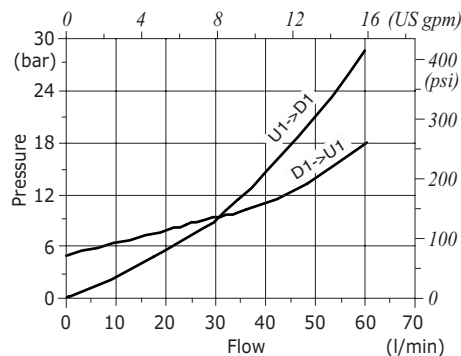

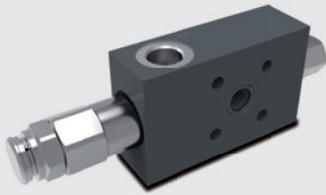

Type VOSLP/N1116 - VOSLP/R1116 counterbalance valves

- Single acting
- External pilot
- Load Sensitive (type N)
- Relief Compensated (type R)

Technical specifications and diagrams are measured with mineral oil of 46 cSt viscosity at 40°C (104°F) temperature.

VOSLP/N1116 (38-12) - VOSLP/R1116 (38-12)

Nominal flow	60 l/min (15.9 US gpm)	
Max. pressure	Aluminium body = 210 bar (3050 psi) Steel body = 350 bar (5100 psi)	
Oil leakage	0.25 cm ³ /min - 0.015 in ³ /min. (5 drops) at 210 bar - 3050 psi	
Fluid	mineral based oil	
Viscosity	from 10 to 200 cSt	
Max. level of contamination	18/16/13 ISO4406	
Fluid temperature	with NBR seals from -20°C (-4°F) to 80°C (176°F)	
Environmental temp. for working conditions	from -40°C (-40°F) to 100°C (212°F)	
Weight	aluminium	VOSLP/N1116/38: 0.51kg (1.12 lb) - VOSLP/N1116/12: 0.65 kg (1.43 lb)
	steel	VOSLP/N1116/38: 1.13 kg (2.49 lb) - VOSLP/N1116/12: 1.51 kg (3.33 lb) VOSLP/R1116/38: 1.20 kg (2.64 lb) - VOSLP/R1116/12: 1.58 kg (3.48 lb)

NOTE - For different conditions, please contact Walvoil Sales Dpt.

VOSLP/N1116

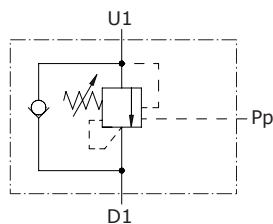

VOSLP/R1116

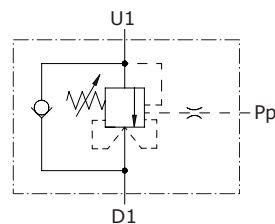

VOSLP/N1116/F1

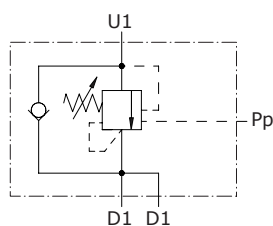

VOSLP/R1116/F1

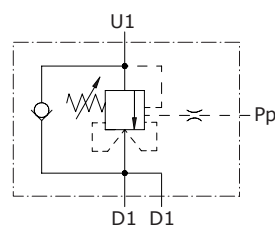

Dimensions

VOSLP/...1116/38 - VOSLP/...1116/12

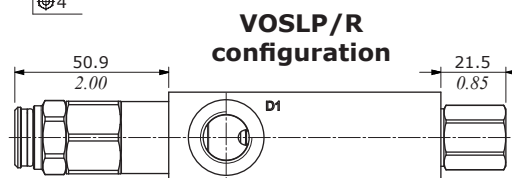
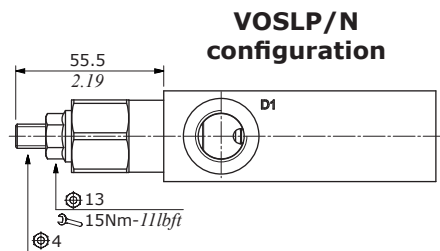
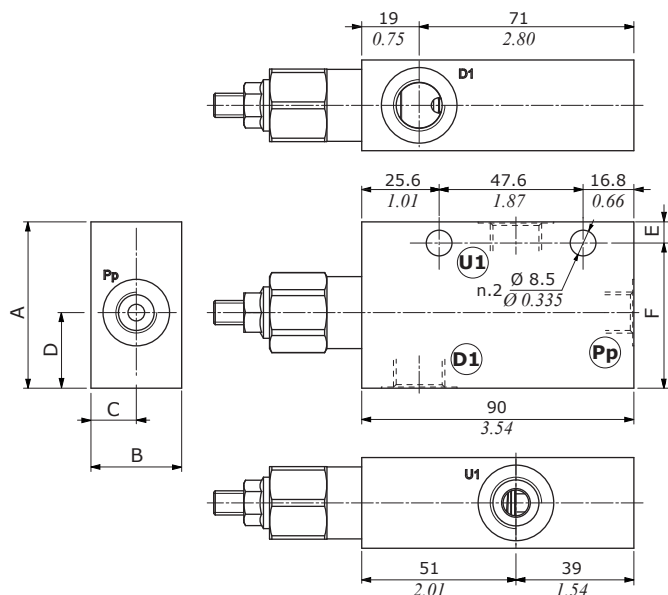

VOSLP/...1116/38F1 - VOSLP/...1116/12F1

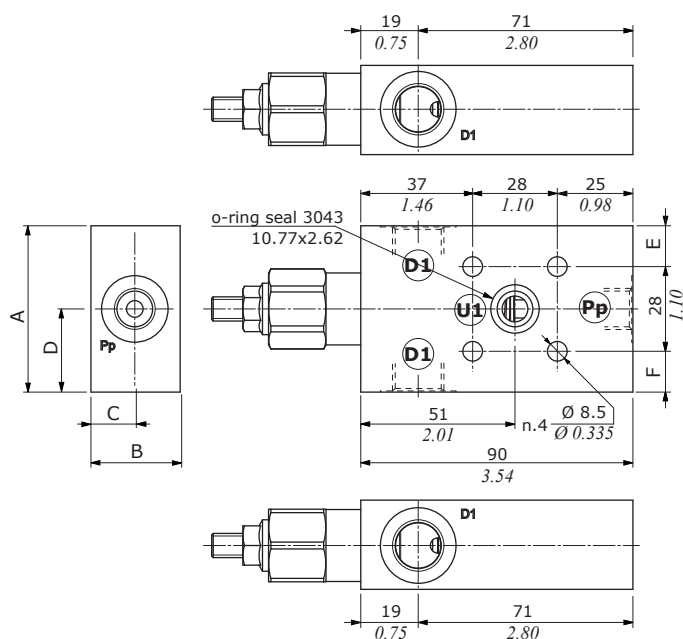

Valve type	D1	U1	Pp
------------	----	----	----

VOSLP/...1116/38 G3/8 G3/8 G1/4

VOSLP/...1116/12 G1/2 G1/2 G1/4

VOSLP/...1116/38F1 G3/8 Ø8.5
Ø0.335 G1/4

VOSLP/...1116/12F1 G1/2 Ø8.5
Ø0.335 G1/4

Valve type	D1	U1	Pp
------------	----	----	----

VOSLP/...1116/S8 SAE8 SAE8 SAE6

VOSLP/...1116/S10 SAE10 SAE10 SAE6

VOSLP/...1116/S8F1 SAE8 Ø8.5
Ø0.335 SAE6

VOSLP/...1116/S10F1 SAE10 Ø8.5
Ø0.335 SAE6

Dimensions are in mm-in

Valve type	A	B	C	D	E	F
VOSLP/...1116/38	55	30	15	25	48	7
VOSLP/...1116/S8	2.17	1.18	0.59	0.98	1.89	0.276
VOSLP/...1116/12	65	35	17.5	32.5	54	11
VOSLP/...1116/S10	2.26	1.38	0.69	1.28	2.13	0.433
VOSLP/...1116/38F1	55	29.5	14.5	27.5	13.5	13.5
VOSLP/...1116/S8F1	2.17	1.16	0.57	1.08	0.53	0.53
VOSLP/...1116/12F1	65	34.5	17	32.5	18.5	18.5
VOSLP/...1116/S10F1	2.26	1.36	0.67	1.28	0.73	0.73

Ordering codes and description composition

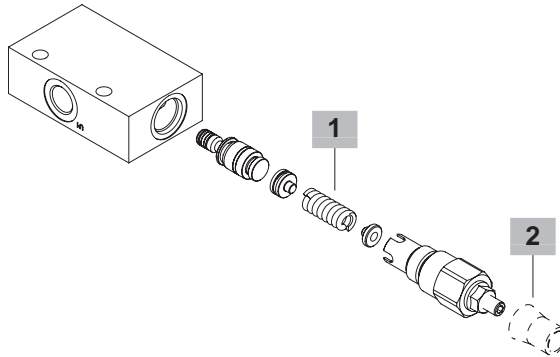
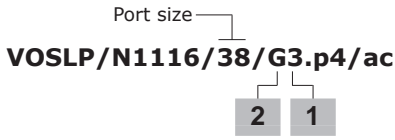

VOSLP/N1116 complete valves

Load sensitive (N) configuration with G3/8 thread

Pilot ratio 1:4

TYPE: **VOSLP/N1116/38/G3.p4/ac** CODE: 1534322101
DESCRIPTION: Steel body, range 5-210 bar (72.5-3050 psi), std setting 150 bar (2175 psi) @ 5 l/min (1.32 US gpm)

TYPE: **VOSLP/N1116/38/G5.p4/ac** CODE: 1534322100
DESCRIPTION: Steel body, range 50-350 bar (725-5075 psi). std setting 280 bar (4060 psi) @ 5 l/min (1.32 US gpm)

TYPE: **VOSLP/N1116/38/G5.p4** CODE: 1534321100
DESCRIPTION: Aluminium body, range 50-350 bar (725-5075 psi), std setting 280 bar (4060 psi) @ 5 l/min (1.32 US gpm)

Pilot ratio 1:8

TYPE: **VOSLP/N1116/38/G5.p8/ac** CODE: 1534322104
DESCRIPTION: Steel body, range 5-350 bar (72.5-5075 psi), std setting 280 bar (4060 psi) @ 5 l/min (1.32 US gpm)

Zero differential pilot ratio

TYPE: **VOSLP/N1116/38/G3.p0/ac** CODE: 1534322106
DESCRIPTION: Steel body, range 5-210 bar (72.5-3050 psi), std setting 150 bar (2175 psi) @ 5 l/min (1.32 US gpm)

TYPE: **VOSLP/N1116/38/G5.p0/ac** CODE: 1534322107
DESCRIPTION: Steel body, range 50-350 bar (725-5075 psi), std setting 280 bar (4060 psi) @ 5 l/min (1.32 US gpm)

Load sensitive (N) configuration with G3/8 thread and F1 flange

TYPE: **VOSLP/N1116/38F1/G5.p4/ac** CODE: 1535522100
DESCRIPTION: Steel body, pilot ratio 1:4, range 50-350 bar (725-5075 psi), std setting 280 bar (4060 psi) @ 5 l/min (1.32 US gpm)

TYPE: **VOSLP/N1116/38F1/G5.p8/ac** CODE: 1535522101
DESCRIPTION: Steel body, pilot ratio 1:8, range 5-350 bar (72.5-5075 psi), std setting 280 bar (4060 psi) @ 5 l/min (1.32 US gpm)

TYPE: **VOSLP/N1116/38F1/G5.p0/ac** CODE: 1535522102
DESCRIPTION: Steel body, zero differential pilot ratio, range 50-350 bar (725-5075 psi), std setting 280 bar (4060 psi) @ 5 l/min (1.32 US gpm)

VOSLP/N1116 complete valves

Load sensitive (N) configuration with SAE8 thread

Pilot ratio 1:4

TYPE: **VOSLP/N1116/S8/G3.p4/ac** CODE: 1534322200
DESCRIPTION: Steel body, range 5-210 bar (72.5-3050 psi), std setting 150 bar (2175 psi) @ 5 l/min (1.32 US gpm)

TYPE: **VOSLP/N1116/S8/G5.p4/ac** CODE: 1534322201
DESCRIPTION: Steel body, range 50-350 bar (725-5075 psi). std setting 280 bar (4060 psi) @ 5 l/min (1.32 US gpm)

TYPE: **VOSLP/N1116/S8/G5.p4** CODE: 1534321200
DESCRIPTION: Aluminium body, range 50-350 bar (725-5075 psi), std setting 280 bar (4060 psi) @ 5 l/min (1.32 US gpm)

Pilot ratio 1:8

TYPE: **VOSLP/N1116/S8/G5.p8/ac** CODE: 1534322204
DESCRIPTION: Steel body, range 5-350 bar (72.5-5075 psi), std setting 280 bar (4060 psi) @ 5 l/min (1.32 US gpm)

Zero differential pilot ratio

TYPE: **VOSLP/N1116/S8/G3.p0/ac** CODE: 1534322206
DESCRIPTION: Steel body, range 5-210 bar (72.5-3050 psi), std setting 150 bar (2175 psi) @ 5 l/min (1.32 US gpm)

TYPE: **VOSLP/N1116/S8/G5.p0/ac** CODE: 1534322207
DESCRIPTION: Steel body, range 50-350 bar (725-5075 psi), std setting 280 bar (4060 psi) @ 5 l/min (1.32 US gpm)

Load sensitive (N) configuration with SAE8 thread and F1 flange

TYPE: **VOSLP/N1116/S8F1/G5.p4/ac** CODE: 1535522200
DESCRIPTION: Steel body, pilot ratio 1:4, range 50-350 bar (725-5075 psi), std setting 280 bar (4060 psi) @ 5 l/min (1.32 US gpm)

TYPE: **VOSLP/N1116/S8F1/G5.p8/ac** CODE: 1535522201
DESCRIPTION: Steel body, pilot ratio 1:8, range 5-350 bar (72.5-5075 psi), std setting 280 bar (4060 psi) @ 5 l/min (1.32 US gpm)

TYPE: **VOSLP/N1116/S8F1/G5.p0/ac** CODE: 1535222202
DESCRIPTION: Steel body, zero differential pilot ratio, range 50-350 bar (725-5075 psi), std setting 280 bar (4060 psi) @ 5 l/min (1.32 US gpm)

1 Pressure setting spring

TYPE	CODE	DESCRIPTION
For 1:4 and zero differential pilot ratio		
3	3ML1133201	For range 5-210 bar (72.5-3050 psi)
5	3ML1133200	For range 50-350 bar (725-5075 psi)
For 1:8 pilot ratio		
5	3ML1133201	For range 5-350 bar (72.5-5075 psi)

2 Setting type

TYPE	CODE	DESCRIPTION
G	-	Screw setting
Z	4COP120420	Antitampering cap

Dimensions

Port size
VOSLP/N1116/12/G3.p4/ac

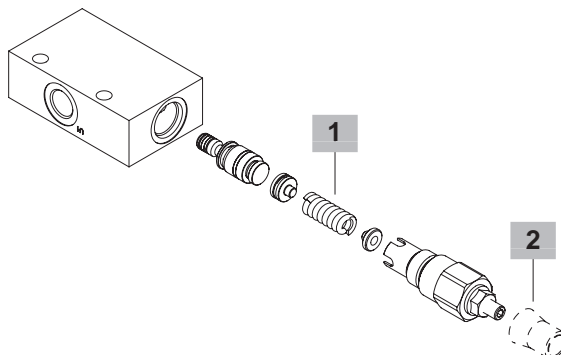

VOSLP/N1116 complete valves

Load sensitive (N) configuration with G1/2 thread

TYPE: **VOSLP/N1116/12/G5.p4/ac** CODE: 1534332100
DESCRIPTION: Steel body, pilot ratio 1:4, range 50-350 bar (725-5075 psi), std setting 280 bar (4060 psi) @ 5 l/min (1.32 US gpm)

TYPE: **VOSLP/N1116/12/G5.p8/ac** CODE: 1534332101
DESCRIPTION: Steel body, pilot ratio 1:8, range 5-350 bar (72.5-5075 psi), std setting 280 bar (4060 psi) @ 5 l/min (1.32 US gpm)

TYPE: **VOSLP/N1116/12/G5.p0/ac** CODE: 1534332102
DESCRIPTION: Steel body, zero differential pilot ratio, range 50-350 bar (725-5075 psi), std setting 280 bar (4060 psi) @ 5 l/min (1.32 US gpm)

TYPE: **VOSLP/N1116/12/G5.p4** CODE: 1534331100
DESCRIPTION: Aluminium body, pilot ratio 1:4, range 50-350 bar (725-5075 psi), std setting 280 bar (4060 psi) @ 5 l/min (1.32 US gpm)

Load sensitive (N) configuration with G1/2 thread and F1 flange

TYPE: **VOSLP/N1116/12F1/G5.p4/ac** CODE: 1535532100
DESCRIPTION: Steel body, pilot ratio 1:4, range 50-350 bar (725-5075 psi), std setting 280 bar (4060 psi) @ 5 l/min (1.32 US gpm)

TYPE: **VOSLP/N1116/12F1/G5.p8/ac** CODE: 1535532101
DESCRIPTION: Steel body, pilot ratio 1:8, range 5-350 bar (72.5-5075 psi), std setting 280 bar (4060 psi) @ 5 l/min (1.32 US gpm)

TYPE: **VOSLP/N1116/12F1/G5.p0/ac** CODE: 1535532102
DESCRIPTION: Steel body, zero differential pilot ratio, range 50-350 bar (725-5075 psi), std setting 280 bar (4060 psi) @ 5 l/min (1.32 US gpm)

For other configurations please contact our Sales Dpt.

VOSLP/N1116 complete valves

Load sensitive (N) configuration with SAE10 thread

TYPE: **VOSLP/N1116/S10/G5.p4/ac** CODE: 1534332200
DESCRIPTION: Steel body, pilot ratio 1:4, range 50-350 bar (725-5075 psi), std setting 280 bar (4060 psi) @ 5 l/min (1.32 US gpm)

TYPE: **VOSLP/N1116/S10/G5.p8/ac** CODE: 1534332201
DESCRIPTION: Steel body, pilot ratio 1:8, range 5-350 bar (72.5-5075 psi), std setting 280 bar (4060 psi) @ 5 l/min (1.32 US gpm)

TYPE: **VOSLP/N1116/S10/G5.p0/ac** CODE: 1534332202
DESCRIPTION: Steel body, zero differential pilot ratio, range 50-350 bar (725-5075 psi), std setting 280 bar (4060 psi) @ 5 l/min (1.32 US gpm)

TYPE: **VOSLP/N1116/S10/G5.p4** CODE: 1534331200
DESCRIPTION: Aluminium body, pilot ratio 1:4, range 50-350 bar (725-5075 psi), std setting 280 bar (4060 psi) @ 5 l/min (1.32 US gpm)

Load sensitive (N) configuration with SAE10 thread and F1 flange

TYPE: **VOSLP/N1116/S10F1/G5.p4/ac** CODE: 1535532200
DESCRIPTION: Steel body, pilot ratio 1:4, range 50-350 bar (725-5075 psi), std setting 280 bar (4060 psi) @ 5 l/min (1.32 US gpm)

TYPE: **VOSLP/N1116/S10F1/G5.p8/ac** CODE: 1535532201
DESCRIPTION: Steel body, pilot ratio 1:8, range 5-350 bar (72.5-5075 psi), std setting 280 bar (4060 psi) @ 5 l/min (1.32 US gpm)

TYPE: **VOSLP/N1116/S10F1/G5.p0/ac** CODE: 1535532202
DESCRIPTION: Steel body, zero differential pilot ratio, range 50-350 bar (725-5075 psi), std setting 280 bar (4060 psi) @ 5 l/min (1.32 US gpm)

For other configurations please contact our Sales Dpt.

1 Pressure setting spring

TYPE	CODE	DESCRIPTION
------	------	-------------

For 1:4 and zero differential pilot ratio

3	3ML1133201	For range 5-210 bar (72.5-3050 psi)
5	3ML1133200	For range 50-350 bar (725-5075 psi)

For 1:8 pilot ratio

5	3ML1133201	For range 5-350 bar (72.5-5075 psi)
----------	------------	-------------------------------------

2 Setting type

TYPE	CODE	DESCRIPTION
G	-	Screw setting
Z	4COP120420	Antitampering cap

Ordering codes and description composition

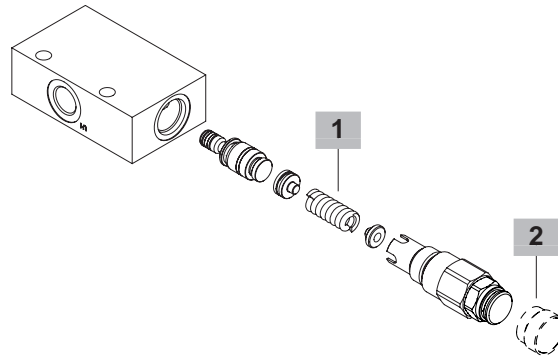
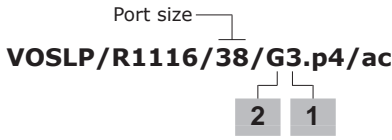

VOSLP/R1116 complete valves

Relief compensated (R) configuration with G3/8 thread

Pilot ratio 1:4

TYPE: **VOSLP/R1116/38/G3.p4/ac** CODE: 1534422101
DESCRIPTION: Steel body, range 5-210 bar (72.5-3050 psi), std setting 150 bar (2175 psi) @ 5 l/min (1.32 US gpm)

TYPE: **VOSLP/R1116/38/G5.p4/ac** CODE: 1534422100
DESCRIPTION: Steel body, range 50-350 bar (725-5075 psi), std setting 280 bar (4060 psi) @ 5 l/min (1.32 US gpm)

Pilot ratio 1:8

TYPE: **VOSLP/R1116/38/G5.p8/ac** CODE: 1534422104
DESCRIPTION: Steel body, range 5-350 bar (72.5-5075 psi), std setting 280 bar (4060 psi) @ 5 l/min (1.32 US gpm)

Zero differential pilot ratio

TYPE: **VOSLP/R1116/38/G3.p0/ac** CODE: 1534422106
DESCRIPTION: Steel body, range 5-210 bar (72.5-3050 psi), std setting 150 bar (2175 psi) @ 5 l/min (1.32 US gpm)

TYPE: **VOSLP/R1116/38/G5.p0/ac** CODE: 1534422107
DESCRIPTION: Steel body, range 50-350 bar (725-5075 psi), std setting 280 bar (4060 psi) @ 5 l/min (1.32 US gpm)

Relief compensated (R) configuration with G3/8 thread and F1 flange

TYPE: **VOSLP/R1116/38F1/G5.p4/ac** CODE: 1535622100
DESCRIPTION: Steel body, pilot ratio 1:4, range 50-350 bar (725-5075 psi), std setting 280 bar (4060 psi) @ 5 l/min (1.32 US gpm)

TYPE: **VOSLP/R1116/38F1/G5.p8/ac** CODE: 1535622101
DESCRIPTION: Steel body, pilot ratio 1:8, range 5-350 bar (72.5-5075 psi), std setting 280 bar (4060 psi) @ 5 l/min (1.32 US gpm)

TYPE: **VOSLP/R1116/38F1/G5.p0/ac** CODE: 1535622102
DESCRIPTION: Steel body, zero differential pilot ratio, range 50-350 bar (725-5075 psi), std setting 280 bar (4060 psi) @ 5 l/min (1.32 US gpm)

VOSLP/R1116 complete valves

Relief compensated (R) configuration with SAE8 thread

Pilot ratio 1:4

TYPE: **VOSLP/R1116/S8/G3.p4/ac** CODE: 1534422200
DESCRIPTION: Steel body, range 5-210 bar (72.5-3050 psi), std setting 150 bar (2175 psi) @ 5 l/min (1.32 US gpm)

TYPE: **VOSLP/R1116/S8/G5.p4/ac** CODE: 1534422201
DESCRIPTION: Steel body, range 50-350 bar (725-5075 psi), std setting 280 bar (4060 psi) @ 5 l/min (1.32 US gpm)

Pilot ratio 1:8

TYPE: **VOSLP/R1116/S8/G5.p8/ac** CODE: 1534422204
DESCRIPTION: Steel body, range 5-350 bar (72.5-5075 psi), std setting 280 bar (4060 psi) @ 5 l/min (1.32 US gpm)

Zero differential pilot ratio

TYPE: **VOSLP/R1116/S8/G3.p0/ac** CODE: 1534422206
DESCRIPTION: Steel body, range 5-210 bar (72.5-3050 psi), std setting 150 bar (2175 psi) @ 5 l/min (1.32 US gpm)

TYPE: **VOSLP/R1116/S8/G5.p0/ac** CODE: 1534422207
DESCRIPTION: Steel body, range 50-350 bar (725-5075 psi), std setting 280 bar (4060 psi) @ 5 l/min (1.32 US gpm)

Relief compensated (R) configuration with SAE8 thread and F1 flange

TYPE: **VOSLP/R1116/S8F1/G5.p4/ac** CODE: 1535622200
DESCRIPTION: Steel body, pilot ratio 1:4, range 50-350 bar (725-5075 psi), std setting 280 bar (4060 psi) @ 5 l/min (1.32 US gpm)

TYPE: **VOSLP/R1116/S8F1/G5.p8/ac** CODE: 1535622201
DESCRIPTION: Steel body, pilot ratio 1:8, range 5-350 bar (72.5-5075 psi), std setting 280 bar (4060 psi) @ 5 l/min (1.32 US gpm)

TYPE: **VOSLP/R1116/S8F1/G5.p0/ac** CODE: 1535522202
DESCRIPTION: Steel body, zero differential pilot ratio, range 50-350 bar (725-5075 psi), std setting 280 bar (4060 psi) @ 5 l/min (1.32 US gpm)

1 Pressure setting spring

TYPE CODE DESCRIPTION

For 1:4 and zero differential pilot ratio

3 3ML1133201 For range 5-210 bar (72.5-3050 psi)
5 3ML1133200 For range 50-350 bar (725-5075 psi)

For 1:8 pilot ratio

5 3ML1133201 For range 5-350 bar (72.5-5075 psi)

2 Setting type

TYPE CODE DESCRIPTION

G - Screw setting
Z 4COP130200 Antitampering cap

Ordering codes and description composition

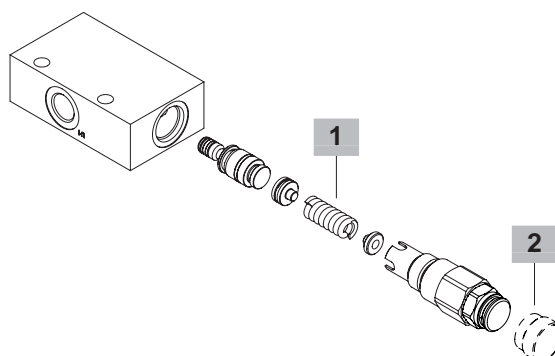
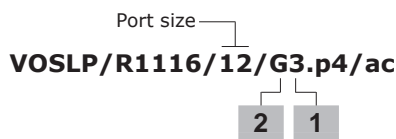

VOSLP/R1116 complete valves

Relief compensated (R) configuration with G1/2 thread

TYPE: **VOSLP/R1116/12/G5.p4/ac** CODE: 1534432100
DESCRIPTION: Steel body, pilot ratio 1:4, range 50-350 bar (725-5075 psi), std setting 280 bar (4060 psi) @ 5 l/min (1.32 US gpm)

TYPE: **VOSLP/R1116/12/G5.p8/ac** CODE: 1534432101
DESCRIPTION: Steel body, pilot ratio 1:8, range 5-350 bar (72.5-5075 psi), std setting 280 bar (4060 psi) @ 5 l/min (1.32 US gpm)

TYPE: **VOSLP/R1116/12/G5.p0/ac** CODE: 1534432102
DESCRIPTION: Steel body, zero differential pilot ratio, range 50-350 bar (725-5075 psi), std setting 280 bar (4060 psi) @ 5 l/min (1.32 US gpm)

Relief compensated (R) configuration with G1/2 thread and F1 flange

TYPE: **VOSLP/R1116/12F1/G5.p4/ac** CODE: 1535632100
DESCRIPTION: Steel body, pilot ratio 1:4, range 50-350 bar (725-5075 psi), std setting 280 bar (4060 psi) @ 5 l/min (1.32 US gpm)

TYPE: **VOSLP/R1116/12F1/G5.p8/ac** CODE: 1535632101
DESCRIPTION: Steel body, pilot ratio 1:8, range 5-350 bar (72.5-5075 psi), std setting 280 bar (4060 psi) @ 5 l/min (1.32 US gpm)

TYPE: **VOSLP/R1116/12F1/G5.p0/ac** CODE: 1535632102
DESCRIPTION: Steel body, zero differential pilot ratio, range 50-350 bar (725-5075 psi), std setting 280 bar (4060 psi) @ 5 l/min (1.32 US gpm)

For other configurations please contact our Sales Dpt.

VOSLP/R1116 complete valves

Relief compensated (R) configuration with SAE10 thread

TYPE: **VOSLP/R1116/S10/G5.p4/ac** CODE: 1534432200
DESCRIPTION: Steel body, pilot ratio 1:4, range 50-350 bar (725-5075 psi), std setting 280 bar (4060 psi) @ 5 l/min (1.32 US gpm)

TYPE: **VOSLP/R1116/S10/G5.p8/ac** CODE: 1534432201
DESCRIPTION: Steel body, pilot ratio 1:8, range 5-350 bar (72.5-5075 psi), std setting 280 bar (4060 psi) @ 5 l/min (1.32 US gpm)

TYPE: **VOSLP/R1116/S10/G5.p0/ac** CODE: 1534432202
DESCRIPTION: Steel body, zero differential pilot ratio, range 50-350 bar (725-5075 psi), std setting 280 bar (4060 psi) @ 5 l/min (1.32 US gpm)

Relief compensated (R) configuration with SAE10 thread and F1 flange

TYPE: **VOSLP/R1116/S10F1/G5.p4/ac** CODE: 1535632200
DESCRIPTION: Steel body, pilot ratio 1:4, range 50-350 bar (725-5075 psi), std setting 280 bar (4060 psi) @ 5 l/min (1.32 US gpm)

TYPE: **VOSLP/R1116/S10F1/G5.p8/ac** CODE: 1535632201
DESCRIPTION: Steel body, pilot ratio 1:8, range 5-350 bar (72.5-5075 psi), std setting 280 bar (4060 psi) @ 5 l/min (1.32 US gpm)

TYPE: **VOSLP/R1116/S10F1/G5.p0/ac** CODE: 1535632202
DESCRIPTION: Steel body, zero differential pilot ratio, range 50-350 bar (725-5075 psi), std setting 280 bar (4060 psi) @ 5 l/min (1.32 US gpm)

For other configurations please contact our Sales Dpt.

1 Pressure setting spring

TYPE	CODE	DESCRIPTION
For 1:4 and zero differential pilot ratio		
3	3ML1133201	For range 5-210 bar (72.5-3050 psi)
5	3ML1133200	For range 50-350 bar (725-5075 psi)
For 1:8 pilot ratio		
5	3ML1133201	For range 5-350 bar (72.5-5075 psi)

2 Setting type

TYPE	CODE	DESCRIPTION
G	-	Screw setting
Z	4COP130200	Antitampering cap

VOSLP/(N-R) 1116 (38-12) pressure drop vs. flow
from D1->U1 and U1->D1

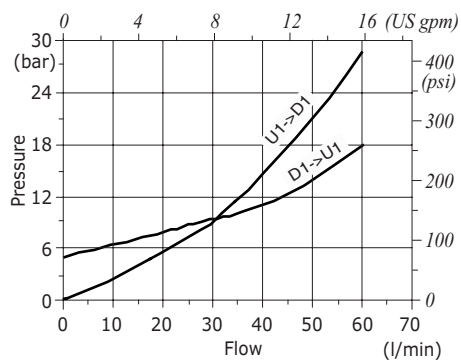



Type VODL/N1116 - VODL/R1116 counterbalance valves

- Double acting
- Load Sensitive (type N)
- Relief Compensated (type R)

Technical specifications and diagrams are measured with mineral oil of 46 cSt viscosity at 40°C (104°F) temperature.

VODL/N1116 (38-12) - VODL/R1116 (38-12)

Nominal flow	60 l/min (15.9 US gpm)
Max. pressure	Aluminium body = 210 bar (3050 psi) Steel body = 350 bar (5100 psi)
Oil leakage	0.25 cm ³ /min - 0.015 in ³ /min. (5 drops) at 210 bar - 3050 psi
Fluid	mineral based oil
Viscosity	from 10 to 200 cSt
Max. level of contamination	18/16/13 ISO4406
Fluid temperature	with NBR seals from -20°C (-4°F) to 80°C (176°F)
Environmental temp. for working conditions	from -40°C (-40°F) to 100°C (212°F)

Weight	aluminium	VODL/N1116/38: 0.91 kg (2.01 lb) - VODL/N1116/12: 1.13 kg (2.49 lb)
	steel	VODL/R1116/38: 1.06 kg (2.34 lb) - VODL/R1116/12: 1.29 kg (2.84 lb)
		VODL/N1116/38: 1.91 kg (4.21 lb) - VODL/N1116/12: 2.55 kg (5.62 lb)
		VODL/R1116/38: 2.06 kg (4.54 lb) - VODL/R1116/12: 2.69 kg (5.93 lb)

NOTE - For different conditions, please contact Walvoil Sales Dpt.

VODL/N1116
VODL/N1116/F2

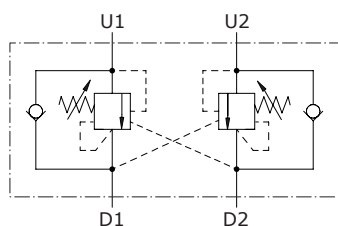

VODL/N1116/PB

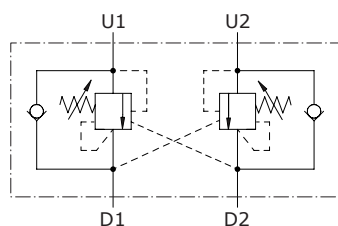

VODL/N1116/F1

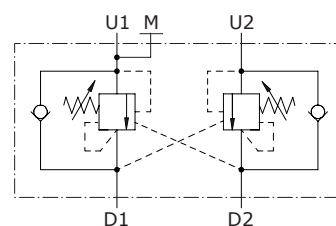

VODL/R1116
VODL/R1116/F2

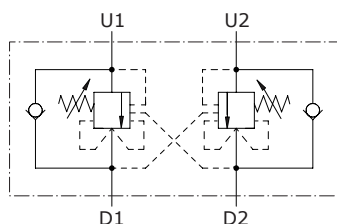

VODL/R1116/F1

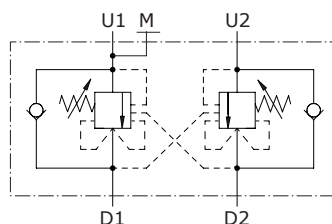

Dimensions

VODL/...1116/38 - VODL/...1116/12

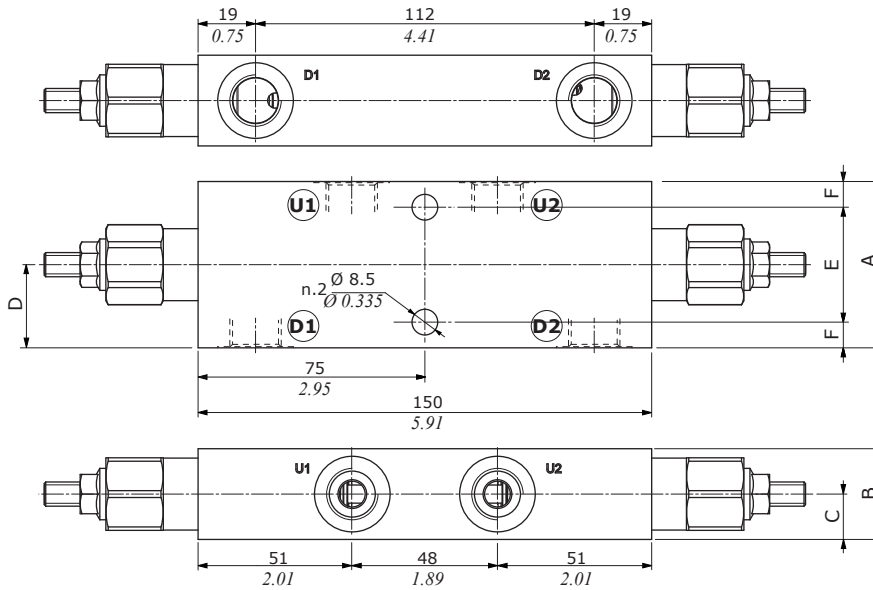

VODL/...1116/38F1 - VODL/...1116/12F1

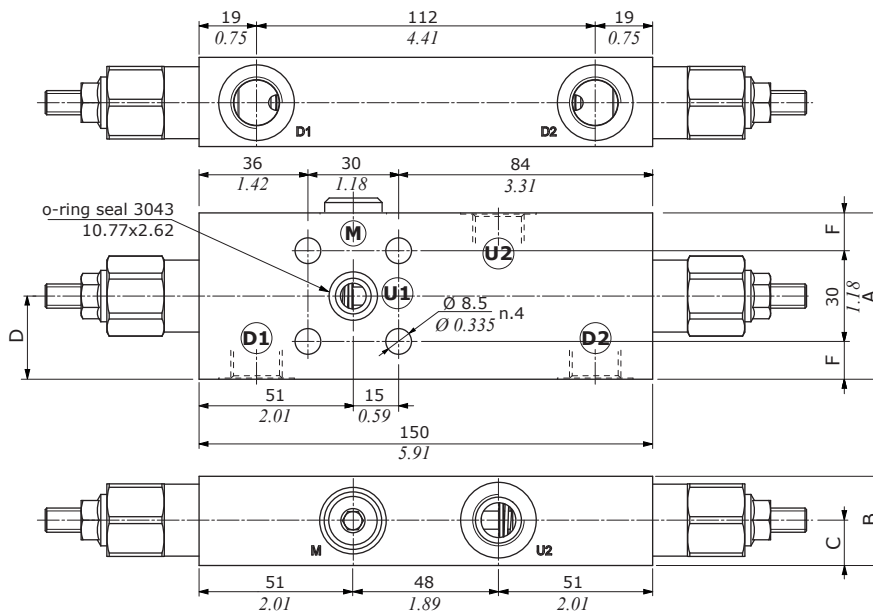

VODL/...1116/38F2 - VODL/...1116/12F2

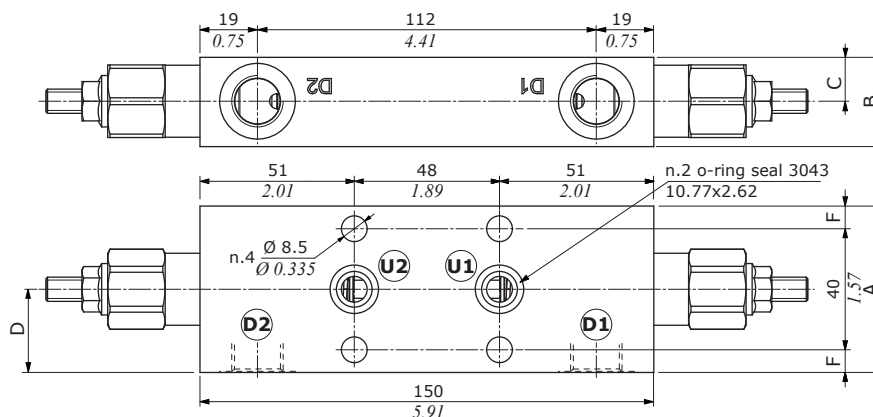

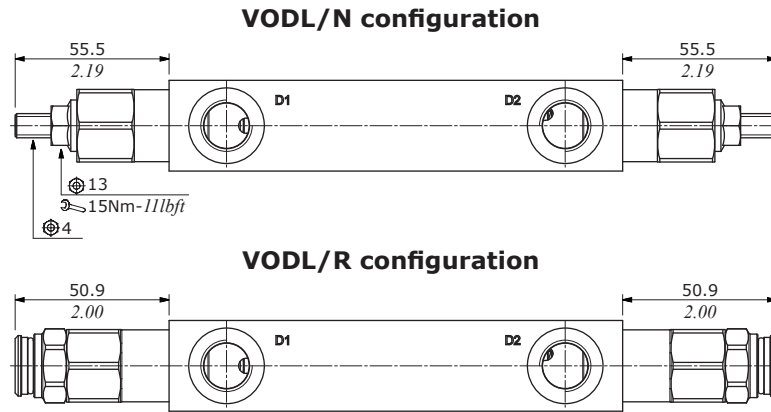

Valve type	D1	D2	U1	U2	M
VODL/...1116/38	G3/8	G3/8	G3/8	G3/8	-
VODL/...1116/12	G1/2	G1/2	G1/2	G1/2	-
VODL/...1116/38F1	G3/8	G3/8	Ø8.5 - Ø0.335	G3/8	G1/4
VODL/...1116/12F1	G1/2	G1/2	Ø8.5 - Ø0.335	G1/2	G1/4
VODL/...1116/38F2	G3/8	G3/8	Ø8.5 - Ø0.335	Ø8.5 - Ø0.335	-
VODL/...1116/12F2	G1/2	G1/2	Ø8.5 - Ø0.335	Ø8.5 - Ø0.335	-

Valve type	D1	D2	U1	U2	M
VODL/...1116/S8	SAE8	SAE8	SAE8	SAE8	-
VODL/...1116/S10	SAE10	SAE10	SAE10	SAE10	-
VODL/...1116/S8F1	SAE8	SAE8	Ø8.5 - Ø0.335	SAE8	G1/4
VODL/...1116/S10F1	SAE10	SAE10	Ø8.5 - Ø0.335	SAE10	G1/4
VODL/...1116/S8F2	SAE8	SAE8	Ø8.5 - Ø0.335	Ø8.5 - Ø0.335	-
VODL/...1116/S10F2	SAE10	SAE10	Ø8.5 - Ø0.335	Ø8.5 - Ø0.335	-

Dimensions are in mm-in

Valve type	A	B	C	D	E	F	G
VODL/...1116/38	55	30	15	27.5	38	8.5	8.5
VODL/...1116/S8	2.17	1.18	0.59	1.08	1.50	0.334	0.334
VODL/...1116/12	65	35	17.5	32.5	43	11	11
VODL/...1116/S10	2.26	1.38	0.69	1.28	1.69	0.433	0.433
VODL/...1116/38F1	55	29.5	15	27.5	30	7.5	7.5
VODL/...1116/s8F1	2.17	1.16	0.59	1.08	1.18	0.295	0.295
VODL/...1116/12F1	65	34.5	17	32.5	30	17.5	17.5
VODL/...1116/S10F1	2.26	1.36	0.67	1.28	1.18	0.69	0.69
VODL/...1116/38F2	55	29.5	14.5	27.5	40	7.5	7.5
VODL/...1116/S8F2	2.17	1.16	0.57	1.08	1.57	0.295	0.295
VODL/...1116/12F2	65	34.5	17	32.5	40	12.5	12.5
VODL/...1116/S10F2	2.26	1.36	0.67	1.28	1.57	0.49	0.49

VODL/N1116/38PB - VODL/N1116/12PB

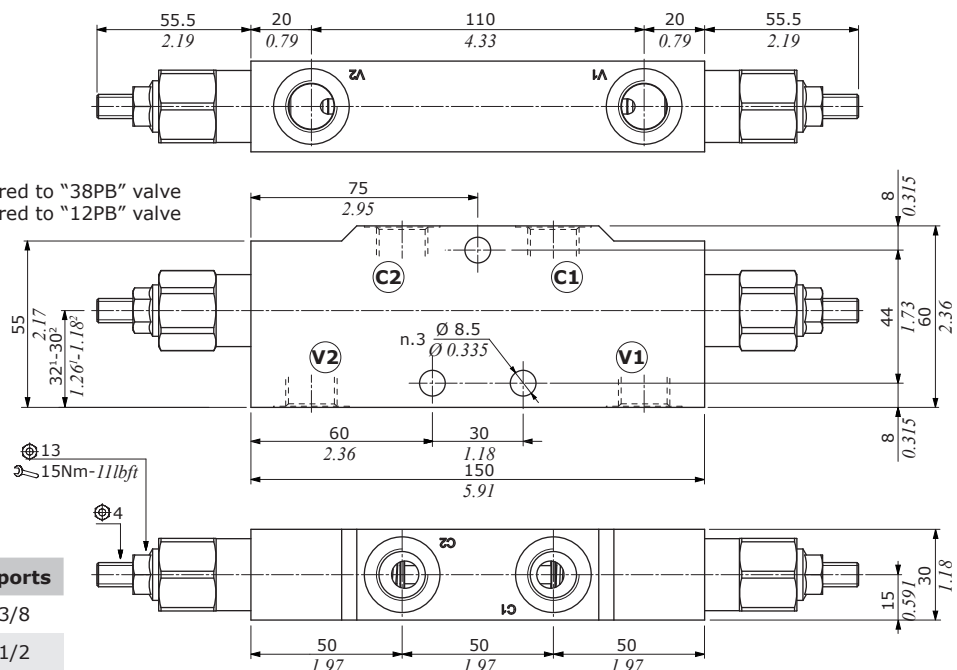

NOTES

- (1): dimension referred to "38PB" valve
- (2): dimension referred to "12PB" valve

Valve type	All ports
VODL/N1116/38PB	G3/8
VODL/N1116/12PB	G1/2

Ordering codes and description composition

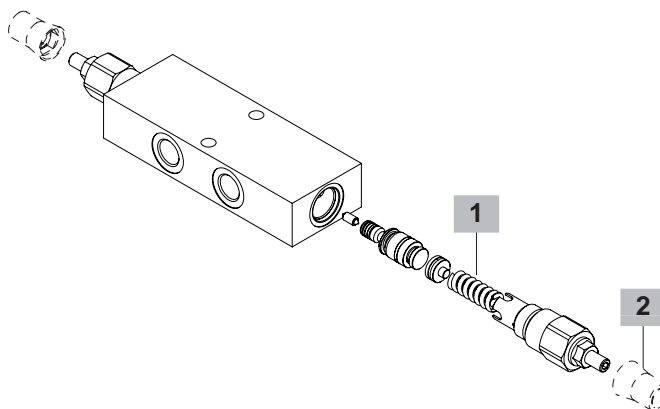
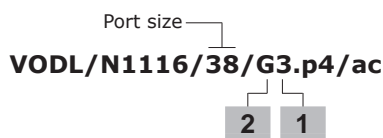

VODL/N1116 complete valves

Load sensitive (N) configuration with G3/8 thread

Pilot ratio 1:4

TYPE: **VODL/N1116/38/G3.p4/ac** CODE: 1554322103
DESCRIPTION: Steel body, range 5-210 bar (72.5-3050 psi), std setting 150 bar (2175 psi) @ 5 l/min (1.32 US gpm)

TYPE: **VODL/N1116/38/G5.p4/ac** CODE: 1554322100
DESCRIPTION: Steel body, range 50-350 bar (725-5075 psi), std setting 280 bar (4060 psi) @ 5 l/min (1.32 US gpm)

TYPE: **VODL/N1116/38/G5.p4** CODE: 1554321100
DESCRIPTION: Aluminium body, range 50-350 bar (725-5075 psi), std setting 280 bar (4060 psi) @ 5 l/min (1.32 US gpm)

Pilot ratio 1:8

TYPE: **VODL/N1116/38/G5.p8/ac** CODE: 1554322106
DESCRIPTION: Steel body, range 5-350 bar (72.5-5075 psi), std setting 280 bar (4060 psi) @ 5 l/min (1.32 US gpm)

Zero differential pilot ratio

TYPE: **VODL/N1116/38/G3.p0/ac** CODE: 1554322108
DESCRIPTION: Steel body, range 5-210 bar (72.5-3050 psi), std setting 150 bar (2175 psi) @ 5 l/min (1.32 US gpm)

TYPE: **VODL/N1116/38/G5.p0/ac** CODE: 1554322109
DESCRIPTION: Steel body, range 50-350 bar (725-5075 psi), std setting 280 bar (4060 psi) @ 5 l/min (1.32 US gpm)

Load sensitive (N) configuration with G3/8 thread and F1 flange

TYPE: **VODL/N1116/38F1/G5.p4/ac** CODE: 1555122100
DESCRIPTION: Steel body, pilot ratio 1:4, range 50-350 bar (725-5075 psi), std setting 280 bar (4060 psi) @ 5 l/min (1.32 US gpm)

TYPE: **VODL/N1116/38F1/G5.p8/ac** CODE: 1555122101
DESCRIPTION: Steel body, pilot ratio 1:8, range 5-350 bar (72.5-5075 psi), std setting 280 bar (4060 psi) @ 5 l/min (1.32 US gpm)

TYPE: **VODL/N1116/38F1/G5.p0/ac** CODE: 1555122102
DESCRIPTION: Steel body, zero differential pilot ratio, range 50-350 bar (725-5075 psi), std setting 280 bar (4060 psi) @ 5 l/min (1.32 US gpm)

Load sensitive (N) configuration with G3/8 thread and F2 flange

TYPE: **VODL/N1116/38F2/G5.p4/ac** CODE: 1555122103
DESCRIPTION: Steel body, pilot ratio 1:4, range 50-350 bar (725-5075 psi), std setting 280 bar (4060 psi) @ 5 l/min (1.32 US gpm)

TYPE: **VODL/N1116/38F2/G5.p8/ac** CODE: 1555122104
DESCRIPTION: Steel body, pilot ratio 1:8, range 5-350 bar (72.5-5075 psi), std setting 280 bar (4060 psi) @ 5 l/min (1.32 US gpm)

TYPE: **VODL/N1116/38F2/G5.p0/ac** CODE: 1555122105
DESCRIPTION: Steel body, zero differential pilot ratio, range 50-350 bar (725-5075 psi), std setting 280 bar (4060 psi) @ 5 l/min (1.32 US gpm)

VODL/N1116 complete valves

Load sensitive (N) configuration with SAE8 thread

Pilot ratio 1:4

TYPE: **VODL/N1116/S8/G3.p4/ac** CODE: 1554322200
DESCRIPTION: Steel body, range 5-210 bar (72.5-3050 psi), std setting 150 bar (2175 psi) @ 5 l/min (1.32 US gpm)

TYPE: **VODL/N1116/S8/G5.p4/ac** CODE: 1554322201
DESCRIPTION: Steel body, range 50-350 bar (725-5075 psi), std setting 280 bar (4060 psi) @ 5 l/min (1.32 US gpm)

TYPE: **VODL/N1116/S8/G5.p4** CODE: 1554321200
DESCRIPTION: Aluminium body, range 50-350 bar (725-5075 psi), std setting 280 bar (4060 psi) @ 5 l/min (1.32 US gpm)

Pilot ratio 1:8

TYPE: **VODL/N1116/S8/G5.p8/ac** CODE: 1554322204
DESCRIPTION: Steel body, range 5-350 bar (72.5-5075 psi), std setting 280 bar (4060 psi) @ 5 l/min (1.32 US gpm)

Zero differential pilot ratio

TYPE: **VODL/N1116/S8/G3.p0/ac** CODE: 1554322206
DESCRIPTION: Steel body, range 5-210 bar (72.5-3050 psi), std setting 150 bar (2175 psi) @ 5 l/min (1.32 US gpm)

TYPE: **VODL/N1116/S8/G5.p0/ac** CODE: 1554322207
DESCRIPTION: Steel body, range 50-350 bar (725-5075 psi), std setting 280 bar (4060 psi) @ 5 l/min (1.32 US gpm)

Load sensitive (N) configuration with SAE8 thread and F1 flange

TYPE: **VODL/N1116/S8F1/G5.p4/ac** CODE: 1555122200
DESCRIPTION: Steel body, pilot ratio 1:4, range 50-350 bar (725-5075 psi), std setting 280 bar (4060 psi) @ 5 l/min (1.32 US gpm)

TYPE: **VODL/N1116/S8F1/G5.p8/ac** CODE: 1555122201
DESCRIPTION: Steel body, pilot ratio 1:8, range 5-350 bar (72.5-5075 psi), std setting 280 bar (4060 psi) @ 5 l/min (1.32 US gpm)

TYPE: **VODL/N1116/S8F1/G5.p0/ac** CODE: 1555122202
DESCRIPTION: Steel body, zero differential pilot ratio, range 50-350 bar (725-5075 psi), std setting 280 bar (4060 psi) @ 5 l/min (1.32 US gpm)

Load sensitive (N) configuration with SAE8 thread and F2 flange

TYPE: **VODL/N1116/S8F2/G5.p4/ac** CODE: 1555122203
DESCRIPTION: Steel body, pilot ratio 1:4, range 50-350 bar (725-5075 psi), std setting 280 bar (4060 psi) @ 5 l/min (1.32 US gpm)

TYPE: **VODL/N1116/S8F2/G5.p8/ac** CODE: 1555122204
DESCRIPTION: Steel body, pilot ratio 1:8, range 5-350 bar (72.5-5075 psi), std setting 280 bar (4060 psi) @ 5 l/min (1.32 US gpm)

TYPE: **VODL/N1116/S8F2/G5.p0/ac** CODE: 1555122205
DESCRIPTION: Steel body, zero differential pilot ratio, range 50-350 bar (725-5075 psi), std setting 280 bar (4060 psi) @ 5 l/min (1.32 US gpm)

VODL/N1116 complete valves

Load sensitive (N) configuration with G1/2 thread

TYPE: **VODL/N1116/12/G5.p4/ac** CODE: 1554332100
DESCRIPTION: Steel body, pilot ratio 1:4, range 50-350 bar (72.5-5075 psi), std setting 280 bar (4060 psi) @ 5 l/min (1.32 US gpm)
TYPE: **VODL/N1116/12/G5.p8/ac** CODE: 1554332101
DESCRIPTION: Steel body, pilot ratio 1:8, range 5-350 bar (72.5-5075 psi), std setting 280 bar (4060 psi) @ 5 l/min (1.32 US gpm)
TYPE: **VODL/N1116/12/G5.p0/ac** CODE: 1554332102
DESCRIPTION: Steel body, zero differential pilot ratio, range 50-350 bar (72.5-5075 psi), std setting 280 bar (4060 psi) @ 5 l/min (1.32 US gpm)
TYPE: **VODL/N1116/12/G5.p4** CODE: 1554331100
DESCRIPTION: Aluminium body, range 50-350 bar (72.5-5075 psi), std setting 280 bar (4060 psi) @ 5 l/min (1.32 US gpm)

Load sensitive (N) configuration with G1/2 thread and F1 flange

TYPE: **VODL/N1116/12F1/G5.p4/ac** CODE: 1555132100
DESCRIPTION: Steel body, pilot ratio 1:4, range 50-350 bar (72.5-5075 psi), std setting 280 bar (4060 psi) @ 5 l/min (1.32 US gpm)
TYPE: **VODL/N1116/12F1/G5.p8/ac** CODE: 1555132101
DESCRIPTION: Steel body, pilot ratio 1:8, range 5-350 bar (72.5-5075 psi), std setting 280 bar (4060 psi) @ 5 l/min (1.32 US gpm)
TYPE: **VODL/N1116/12F1/G5.p0/ac** CODE: 1555132102
DESCRIPTION: Steel body, zero differential pilot ratio, range 50-350 bar (72.5-5075 psi), std setting 280 bar (4060 psi) @ 5 l/min (1.32 US gpm)

Load sensitive (N) configuration with G1/2 thread and F2 flange

TYPE: **VODL/N1116/12F2/G5.p4/ac** CODE: 1555132103
DESCRIPTION: Steel body, pilot ratio 1:4, range 50-350 bar (72.5-5075 psi), std setting 280 bar (4060 psi) @ 5 l/min (1.32 US gpm)
TYPE: **VODL/N1116/12F2/G5.p8/ac** CODE: 1555132104
DESCRIPTION: Steel body, pilot ratio 1:8, range 5-350 bar (72.5-5075 psi), std setting 280 bar (4060 psi) @ 5 l/min (1.32 US gpm)
TYPE: **VODL/N1116/12F2/G5.p0/ac** CODE: 1555132105
DESCRIPTION: Steel body, zero differential pilot ratio, range 50-350 bar (72.5-5075 psi), std setting 280 bar (4060 psi) @ 5 l/min (1.32 US gpm)

For other configurations please contact our Sales Dpt.

VODL/N1116 complete valves

Load sensitive (N) configuration with SAE10 thread

TYPE: **VODL/N1116/S10/G5.p4/ac** CODE: 1554332200
DESCRIPTION: Steel body, pilot ratio 1:4, range 50-350 bar (72.5-5075 psi), std setting 280 bar (4060 psi) @ 5 l/min (1.32 US gpm)
TYPE: **VODL/N1116/S10/G5.p8/ac** CODE: 1554332201
DESCRIPTION: Steel body, pilot ratio 1:8, range 5-350 bar (72.5-5075 psi), std setting 280 bar (4060 psi) @ 5 l/min (1.32 US gpm)
TYPE: **VODL/N1116/S10/G5.p0/ac** CODE: 1554332202
DESCRIPTION: Steel body, zero differential pilot ratio, range 50-350 bar (72.5-5075 psi), std setting 280 bar (4060 psi) @ 5 l/min (1.32 US gpm)
TYPE: **VODL/N1116/S10/G5.p4** CODE: 1554331201
DESCRIPTION: Aluminium body, range 50-350 bar (72.5-5075 psi), std setting 280 bar (4060 psi) @ 5 l/min (1.32 US gpm)

Load sensitive (N) configuration with SAE10 thread and F1 flange

TYPE: **VODL/N1116/S10F1/G5.p4/ac** CODE: 1555132200
DESCRIPTION: Steel body, pilot ratio 1:4, range 50-350 bar (72.5-5075 psi), std setting 280 bar (4060 psi) @ 5 l/min (1.32 US gpm)
TYPE: **VODL/N1116/S10F1/G5.p8/ac** CODE: 1555132201
DESCRIPTION: Steel body, pilot ratio 1:8, range 5-350 bar (72.5-5075 psi), std setting 280 bar (4060 psi) @ 5 l/min (1.32 US gpm)
TYPE: **VODL/N1116/S10F1/G5.p0/ac** CODE: 1555132202
DESCRIPTION: Steel body, zero differential pilot ratio, range 50-350 bar (72.5-5075 psi), std setting 280 bar (4060 psi) @ 5 l/min (1.32 US gpm)

Load sensitive (N) configuration with SAE10 thread and F2 flange

TYPE: **VODL/N1116/S10F2/G5.p4/ac** CODE: 1555132203
DESCRIPTION: Steel body, pilot ratio 1:4, range 50-350 bar (72.5-5075 psi), std setting 280 bar (4060 psi) @ 5 l/min (1.32 US gpm)
TYPE: **VODL/N1116/S10F2/G5.p8/ac** CODE: 1555132204
DESCRIPTION: Steel body, pilot ratio 1:8, range 5-350 bar (72.5-5075 psi), std setting 280 bar (4060 psi) @ 5 l/min (1.32 US gpm)
TYPE: **VODL/N1116/S10F2/G5.p0/ac** CODE: 1555132205
DESCRIPTION: Steel body, zero differential pilot ratio, range 50-350 bar (72.5-5075 psi), std setting 280 bar (4060 psi) @ 5 l/min (1.32 US gpm)

For other configurations please contact our Sales Dpt.

1 Pressure setting spring

TYPE	CODE	DESCRIPTION
For 1:4 and zero differential pilot ratio		
3	3ML1133201	For range 5-210 bar (72.5-3050 psi)
5	3ML1133200	For range 50-350 bar (72.5-5075 psi)
For 1:8 pilot ratio		
5	3ML1133201	For range 5-350 bar (72.5-5075 psi)

2 Setting type

TYPE	CODE	DESCRIPTION
G	-	Screw setting
Z	4COP120420	Antitampering cap

Ordering codes and description composition

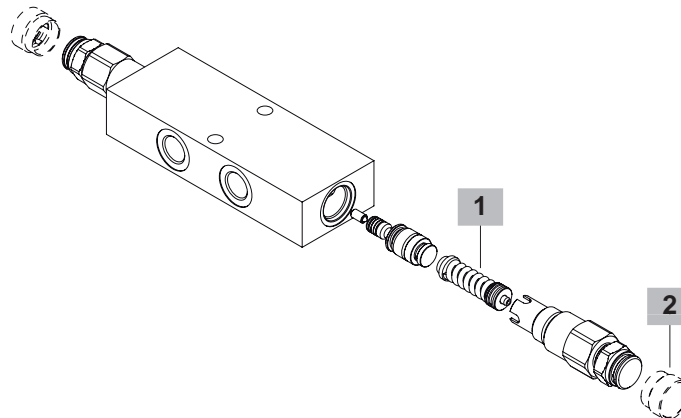
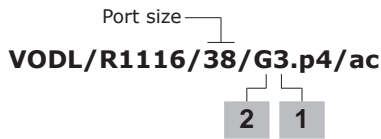

VODL/R1116 complete valves

Relief compensated (R) configuration with G3/8 thread

Pilot ratio 1:4

TYPE: **VODL/R1116/38/G3.p4/ac** CODE: 1554422101
DESCRIPTION: Steel body, range 5-210 bar (72.5-3050 psi), std setting 150 bar (2175 psi) @ 5 l/min (1.32 US gpm)

TYPE: **VODL/R1116/38/G5.p4/ac** CODE: 1554422100
DESCRIPTION: Steel body, range 50-350 bar (725-5075 psi), std setting 280 bar (4060 psi) @ 5 l/min (1.32 US gpm)

TYPE: **VODL/R1116/38/G5.p4** CODE: 1554421100
DESCRIPTION: aluminium body configuration range 50-350 bar (725-5075 psi), std setting 280 bar (4060 psi) @ 5 l/min (1.32 US gpm)

Pilot ratio 1:8

TYPE: **VODL/R1116/38/G5.p8/ac** CODE: 1554422104
DESCRIPTION: Steel body, range 5-350 bar (72.5-5075 psi), std setting 280 bar (4060 psi) @ 5 l/min (1.32 US gpm)

Zero differential pilot ratio

TYPE: **VODL/R1116/38/G3.p0/ac** CODE: 1554422106
DESCRIPTION: Steel body, range 5-210 bar (72.5-3050 psi), std setting 150 bar (2175 psi) @ 5 l/min (1.32 US gpm)

TYPE: **VODL/R1116/38/G5.p0/ac** CODE: 1554422107
DESCRIPTION: Steel body, range 50-350 bar (725-5075 psi), std setting 280 bar (4060 psi) @ 5 l/min (1.32 US gpm)

Relief compensated (R) configuration with G3/8 thread and F1 flange

TYPE: **VODL/R1116/38F1/G5.p4/ac** CODE: 1555022100
DESCRIPTION: Steel body, pilot ratio 1:4, range 50-350 bar (725-5075 psi), std setting 280 bar (4060 psi) @ 5 l/min (1.32 US gpm)

TYPE: **VODL/R1116/38F1/G5.p8/ac** CODE: 1555022101
DESCRIPTION: Steel body, pilot ratio 1:8, range 5-350 bar (72.5-5075 psi), std setting 280 bar (4060 psi) @ 5 l/min (1.32 US gpm)

TYPE: **VODL/R1116/38F1/G5.p0/ac** CODE: 1555022102
DESCRIPTION: Steel body, zero differential pilot ratio, range 50-350 bar (725-5075 psi), std setting 280 bar (4060 psi) @ 5 l/min (1.32 US gpm)

Relief compensated (R) configuration with G3/8 thread and F2 flange

TYPE: **VODL/R1116/38F2/G5.p4/ac** CODE: 1555022103
DESCRIPTION: Steel body, pilot ratio 1:4, range 50-350 bar (725-5075 psi), std setting 280 bar (4060 psi) @ 5 l/min (1.32 US gpm)

TYPE: **VODL/R1116/38F2/G5.p8/ac** CODE: 1555022104
DESCRIPTION: Steel body, pilot ratio 1:8, range 5-350 bar (72.5-5075 psi), std setting 280 bar (4060 psi) @ 5 l/min (1.32 US gpm)

TYPE: **VODL/R1116/38F2/G5.p0/ac** CODE: 1555022105
DESCRIPTION: Steel body, zero differential pilot ratio, range 50-350 bar (725-5075 psi), std setting 280 bar (4060 psi) @ 5 l/min (1.32 US gpm)

VODL/R1116 complete valves

Relief compensated (R) configuration with SAE8 thread

Pilot ratio 1:4

TYPE: **VODL/R1116/S8/G3.p4/ac** CODE: 1554422200
DESCRIPTION: Steel body, range 5-210 bar (72.5-3050 psi), std setting 150 bar (2175 psi) @ 5 l/min (1.32 US gpm)

TYPE: **VODL/R1116/S8/G5.p4/ac** CODE: 1554422201
DESCRIPTION: Steel body, range 50-350 bar (725-5075 psi), std setting 280 bar (4060 psi) @ 5 l/min (1.32 US gpm)

TYPE: **VODL/R1116/S8/G5.p4** CODE: 1554421200
DESCRIPTION: aluminium body configuration range 50-350 bar (725-5075 psi), std setting 280 bar (4060 psi) @ 5 l/min (1.32 US gpm)

Pilot ratio 1:8

TYPE: **VODL/R1116/S8/G5.p8/ac** CODE: 1554422204
DESCRIPTION: Steel body, range 5-350 bar (72.5-5075 psi), std setting 280 bar (4060 psi) @ 5 l/min (1.32 US gpm)

Zero differential pilot ratio

TYPE: **VODL/R1116/S8/G3.p0/ac** CODE: 1554422206
DESCRIPTION: Steel body, range 5-210 bar (72.5-3050 psi), std setting 150 bar (2175 psi) @ 5 l/min (1.32 US gpm)

TYPE: **VODL/R1116/S8/G5.p0/ac** CODE: 1554422207
DESCRIPTION: Steel body, range 50-350 bar (725-5075 psi), std setting 280 bar (4060 psi) @ 5 l/min (1.32 US gpm)

Relief compensated (R) configuration with SAE8 thread and F1 flange

TYPE: **VODL/R1116/S8F1/G5.p4/ac** CODE: 1555022200
DESCRIPTION: Steel body, pilot ratio 1:4, range 50-350 bar (725-5075 psi), std setting 280 bar (4060 psi) @ 5 l/min (1.32 US gpm)

TYPE: **VODL/R1116/S8F1/G5.p8/ac** CODE: 1555022201
DESCRIPTION: Steel body, pilot ratio 1:8, range 5-350 bar (72.5-5075 psi), std setting 280 bar (4060 psi) @ 5 l/min (1.32 US gpm)

TYPE: **VODL/R1116/S8F1/G5.p0/ac** CODE: 1555022202
DESCRIPTION: Steel body, zero differential pilot ratio, range 50-350 bar (725-5075 psi), std setting 280 bar (4060 psi) @ 5 l/min (1.32 US gpm)

Relief compensated (R) configuration with SAE8 thread and F2 flange

TYPE: **VODL/R1116/S8F2/G5.p4/ac** CODE: 1555022203
DESCRIPTION: Steel body, pilot ratio 1:4, range 50-350 bar (725-5075 psi), std setting 280 bar (4060 psi) @ 5 l/min (1.32 US gpm)

TYPE: **VODL/R1116/S8F2/G5.p8/ac** CODE: 1555022204
DESCRIPTION: Steel body, pilot ratio 1:8, range 5-350 bar (72.5-5075 psi), std setting 280 bar (4060 psi) @ 5 l/min (1.32 US gpm)

TYPE: **VODL/R1116/S8F2/G5.p0/ac** CODE: 1555022205
DESCRIPTION: Steel body, zero differential pilot ratio, range 50-350 bar (725-5075 psi), std setting 280 bar (4060 psi) @ 5 l/min (1.32 US gpm)

Ordering codes and description composition

VODL/R1116 complete valves

Relief compensated (R) configuration with G1/2 thread

TYPE: **VODL/R1116/12/G5.p4/ac** CODE: 1554432101
DESCRIPTION: Steel body, pilot ratio 1:4, range 50-350 bar (72.5-5075 psi), std setting 280 bar (4060 psi) @ 5 l/min (1.32 US gpm)

TYPE: **VODL/R1116/12/G5.p8/ac** CODE: 1554432100
DESCRIPTION: Steel body, pilot ratio 1:8, range 5-350 bar (72.5-5075 psi), std setting 280 bar (4060 psi) @ 5 l/min (1.32 US gpm)

TYPE: **VODL/R1116/12/G5.p0/ac** CODE: 1554432102
DESCRIPTION: Steel body, zero differential pilot ratio. Range 50-350 bar (72.5-5075 psi), std setting 280 bar (4060 psi) 5 l/min (1.32 US gpm)

TYPE: **VODL/R1116/12/G5.p4** CODE: 1554431100
DESCRIPTION: Aluminium body, range 50-350 bar (72.5-5075 psi), std setting 280 bar (4060 psi) @ 5 l/min (1.32 US gpm)

Relief compensated (R) configuration with G1/2 thread and F1 flange

TYPE: **VODL/R1116/12F1/G5.p4/ac** CODE: 1555032103
DESCRIPTION: Steel body, pilot ratio 1:4, range 50-350 bar (72.5-5075 psi), std setting 280 bar (4060 psi) 5 l/min (1.32 US gpm)

TYPE: **VODL/R1116/12F1/G5.p8/ac** CODE: 1555032104
DESCRIPTION: pilot ratio 1:8, range 5-350 bar (72.5-5075 psi), std setting 280 bar (4060 psi) 5 l/min (1.32 US gpm)

TYPE: **VODL/R1116/12F1/G5.p0/ac** CODE: 1555032105
DESCRIPTION: Steel body, zero differential pilot ratio, range 50-350 bar (72.5-5075 psi), std setting 280 bar (4060 psi) 5 l/min (1.32 US gpm)

Relief compensated (R) configuration with G1/2 thread and F2 flange

TYPE: **VODL/R1116/12F2/G5.p4/ac** CODE: 1555032100
DESCRIPTION: Steel body, pilot ratio 1:4, range 50-350 bar (72.5-5075 psi), std setting 280 bar (4060 psi) 5 l/min (1.32 US gpm)

TYPE: **VODL/R1116/12F2/G5.p8/ac** CODE: 1555032101
DESCRIPTION: Steel body, pilot ratio 1:8, range 5-350 bar (72.5-5075 psi), std setting 280 bar (4060 psi) 5 l/min (1.32 US gpm)

TYPE: **VODL/R1116/12F2/G5.p0/ac** CODE: 1555032102
DESCRIPTION: Steel body, zero differential pilot ratio, range 50-350 bar (72.5-5075 psi), std setting 280 bar (4060 psi) 5 l/min (1.32 US gpm)

For other configurations please contact our Sales Dpt.

VODL/R1116 complete valves

Relief compensated (R) configuration with SAE10 thread

TYPE: **VODL/R1116/S10/G5.p4/ac** CODE: 1554432200
DESCRIPTION: Steel body, pilot ratio 1:4, range 50-350 bar (72.5-5075 psi), std setting 280 bar (4060 psi) @ 5 l/min (1.32 US gpm)

TYPE: **VODL/R1116/S10/G5.p8/ac** CODE: 1554432201
DESCRIPTION: Steel body, pilot ratio 1:8, range 5-350 bar (72.5-5075 psi), std setting 280 bar (4060 psi) @ 5 l/min (1.32 US gpm)

TYPE: **VODL/R1116/S10/G5.p0/ac** CODE: 1554432202
DESCRIPTION: Steel body, zero differential pilot ratio. Range 50-350 bar (72.5-5075 psi), std setting 280 bar (4060 psi) 5 l/min (1.32 US gpm)

TYPE: **VODL/R1116/S10/G5.p4** CODE: 1554431200
DESCRIPTION: Aluminium body, range 50-350 bar (72.5-5075 psi), std setting 280 bar (4060 psi) @ 5 l/min (1.32 US gpm)

Relief compensated (R) configuration with SAE10 thread and F1 flange

TYPE: **VODL/R1116/S10F1/G5.p4/ac** CODE: 1555032200
DESCRIPTION: Steel body, pilot ratio 1:4, range 50-350 bar (72.5-5075 psi), std setting 280 bar (4060 psi) 5 l/min (1.32 US gpm)

TYPE: **VODL/R1116/S10F1/G5.p8/ac** CODE: 1555032201
DESCRIPTION: pilot ratio 1:8, range 5-350 bar (72.5-5075 psi), std setting 280 bar (4060 psi) 5 l/min (1.32 US gpm)

TYPE: **VODL/R1116/S10F1/G5.p0/ac** CODE: 1555032202
DESCRIPTION: Steel body, zero differential pilot ratio, range 50-350 bar (72.5-5075 psi), std setting 280 bar (4060 psi) 5 l/min (1.32 US gpm)

Relief compensated (R) configuration with SAE10 thread and F2 flange

TYPE: **VODL/R1116/S10F2/G5.p4/ac** CODE: 1555032203
DESCRIPTION: Steel body, pilot ratio 1:4, range 50-350 bar (72.5-5075 psi), std setting 280 bar (4060 psi) 5 l/min (1.32 US gpm)

TYPE: **VODL/R1116/S10F2/G5.p8/ac** CODE: 1555032204
DESCRIPTION: Steel body, pilot ratio 1:8, range 5-350 bar (72.5-5075 psi), std setting 280 bar (4060 psi) 5 l/min (1.32 US gpm)

TYPE: **VODL/R1116/S10F2/G5.p0/ac** CODE: 1555032205
DESCRIPTION: Steel body, zero differential pilot ratio, range 50-350 bar (72.5-5075 psi), std setting 280 bar (4060 psi) 5 l/min (1.32 US gpm)

For other configurations please contact our Sales Dpt.

1 Pressure setting spring

TYPE	CODE	DESCRIPTION
------	------	-------------

For 1:4 and zero differential pilot ratio

3	3ML1133201	For range 5-210 bar (72.5-3050 psi)
----------	------------	-------------------------------------

5	3ML1133200	For range 50-350 bar (72.5-5075 psi)
----------	------------	--------------------------------------

For 1:8 pilot ratio

5	3ML1133201	For range 5-350 bar (72.5-5075 psi)
----------	------------	-------------------------------------

2 Setting type

TYPE	CODE	DESCRIPTION
------	------	-------------

G	-	Screw setting
----------	---	---------------

Z	4COP130200	Antitampering cap
----------	------------	-------------------

Rating diagrams

Port size
VODL/N1116/38PB/G3.p4/ac

2 1

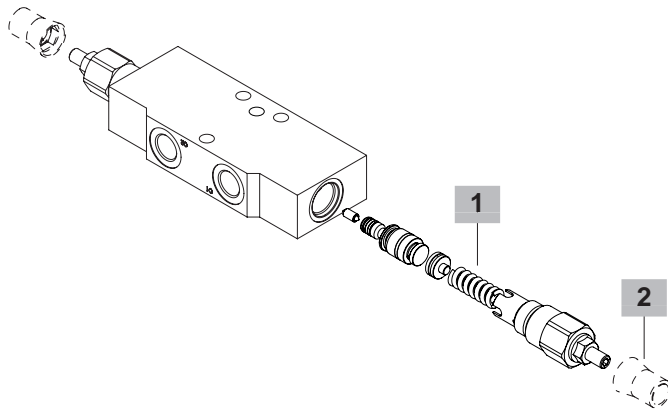

1 Pressure setting spring

TYPE	CODE	DESCRIPTION
For 1:4 and zero differential pilot ratio		
3	3ML1133201	For range 5-210 bar (72.5-3050 psi)
5	3ML1133200	For range 50-350 bar (725-5075 psi)
For 1:8 pilot ratio		
5	3ML1133201	For range 5-350 bar (72.5-5075 psi)

2 Setting type

TYPE	CODE	DESCRIPTION
G	-	Screw setting
Z	4COP120420	Antitampering cap

VODL/N1116/PB complete valves

Load sensitive (N) configuration with G3/8 thread

Pilot ratio 1:4

TYPE: **VODL/N1116/38PB/G3.p4/ac** CODE: 1555422101
DESCRIPTION: Steel body, range 5-210 bar (72.5-3050 psi), std setting 150 bar (2175 psi) @ 5 l/min (1.32 US gpm)

TYPE: **VODL/N1116/38PB/G5.p4/ac** CODE: 1555422100
DESCRIPTION: Steel body, range 50-350 bar (725-5075 psi), std setting 280 bar (4060 psi) @ 5 l/min (1.32 US gpm)

Pilot ratio 1:8

TYPE: **VODL/N1116/38PB/G5.p8/ac** CODE: 1555422102
DESCRIPTION: Steel body, range 5-350 bar (72.5-5075 psi), std setting 280 bar (4060 psi) @ 5 l/min (1.32 US gpm)

Zero differential pilot ratio

TYPE: **VODL/N1116/38PB/G5.p0/ac** CODE: 1555422103
DESCRIPTION: Steel body, range 5-350 bar (72.5-5075 psi), std setting 280 bar (4060 psi) @ 5 l/min (1.32 US gpm)

Load sensitive (N) configuration with G1/2 thread

Pilot ratio 1:4

TYPE: **VODL/N1116/12PB/G3.p4/ac** CODE: 1555432101
DESCRIPTION: Steel body, range 5-210 bar (72.5-3050 psi), std setting 150 bar (2175 psi) @ 5 l/min (1.32 US gpm)

TYPE: **VODL/N1116/2PB/G5.p4/ac** CODE: 1555432100
DESCRIPTION: Steel body, range 50-350 bar (725-5075 psi), std setting 280 bar (4060 psi) @ 5 l/min (1.32 US gpm)

Pilot ratio 1:8

TYPE: **VODL/N1116/12PB/G5.p8/ac** CODE: 1555432102
DESCRIPTION: Steel body, range 5-350 bar (72.5-5075 psi), std setting 280 bar (4060 psi) @ 5 l/min (1.32 US gpm)

Zero differential pilot ratio

TYPE: **VODL/N1116/12PB/G5.p0/ac** CODE: 1555432103
DESCRIPTION: Steel body, range 5-350 bar (72.5-5075 psi), std setting 280 bar (4060 psi) @ 5 l/min (1.32 US gpm)

For other configurations please contact our Sales Dpt.

Rating diagrams

VODL/(N-R) 1116 (38-12) pressure drop vs. flow from D1->U1 and U1->D1 (D2->U2 and U2->D2)

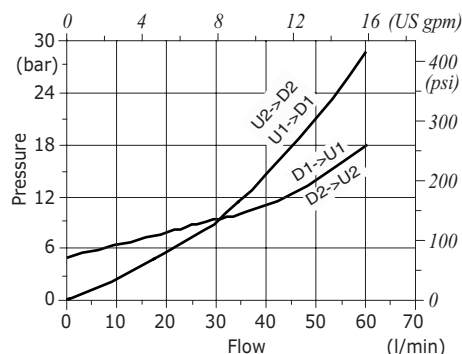

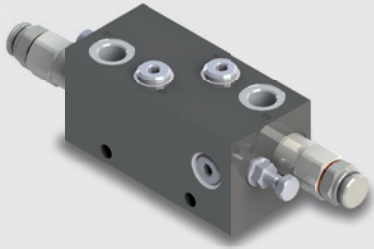

Type VODL/V1116/CS counterbalance valves

- Double acting
- Vented

Technical specifications and diagrams are measured with mineral oil of 46 cSt viscosity at 40°C (104°F) temperature.

VODL/V1116/CS (38-12)

Nominal flow	60 l/min (15.9 US gpm)
Max. pressure	350 bar (5100 psi)
Oil leakage	0.25 cm ³ /min - 0.015 in ³ /min. (5 drops) at 210 bar - 3050 psi
Fluid	mineral based oil
Viscosity	from 10 to 200 cSt
Max. level of contamination	18/16/13 ISO4406
Fluid temperature	with NBR seals from -20°C (-4°F) to 80°C (176°F)
Environmental temp. for working conditions	from -40°C (-40°F) to 100°C (212°F)
Weight	VODL/V1116/CS/38: 3.64 kg (8.02 lb) - VODL/V1116/CS/12: 3.50 kg (7.72 lb)

NOTE - For different conditions, please contact Walvoil Sales Dpt.

VODL/V1116/CS

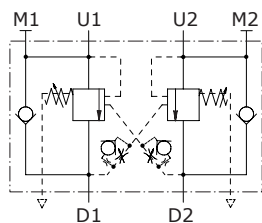

VODL/V1116/CS/F2

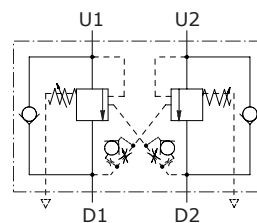

Dimensions

VODL/V1116/CS/38 - VODL/V1116/CS/12

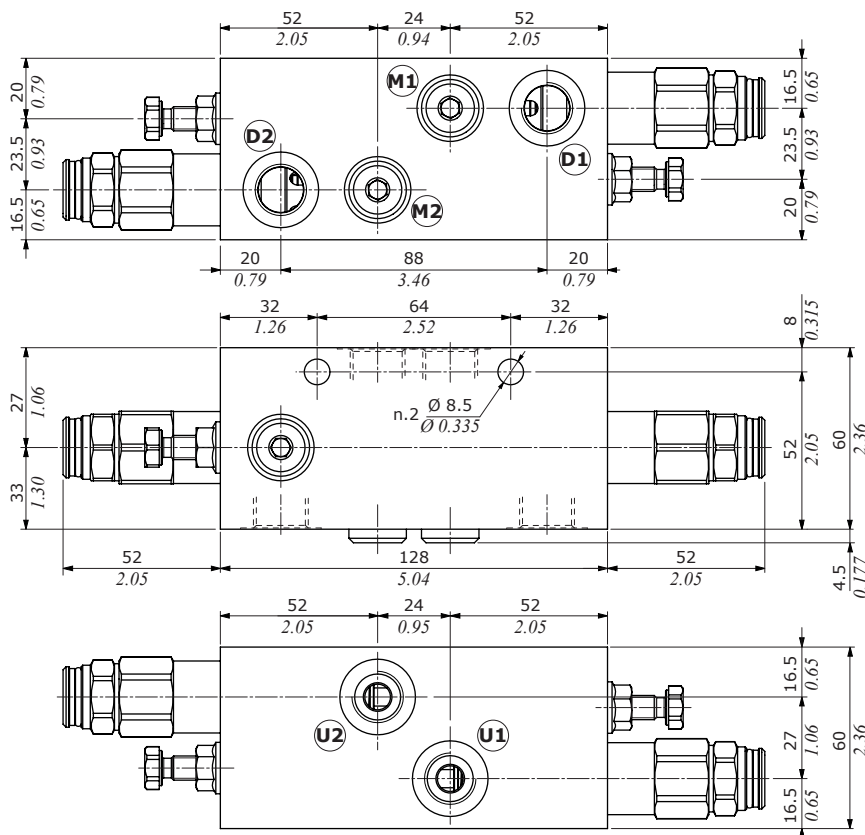

VODL/V1116/CS/38F2 - VODL/V1116/CS/12F2

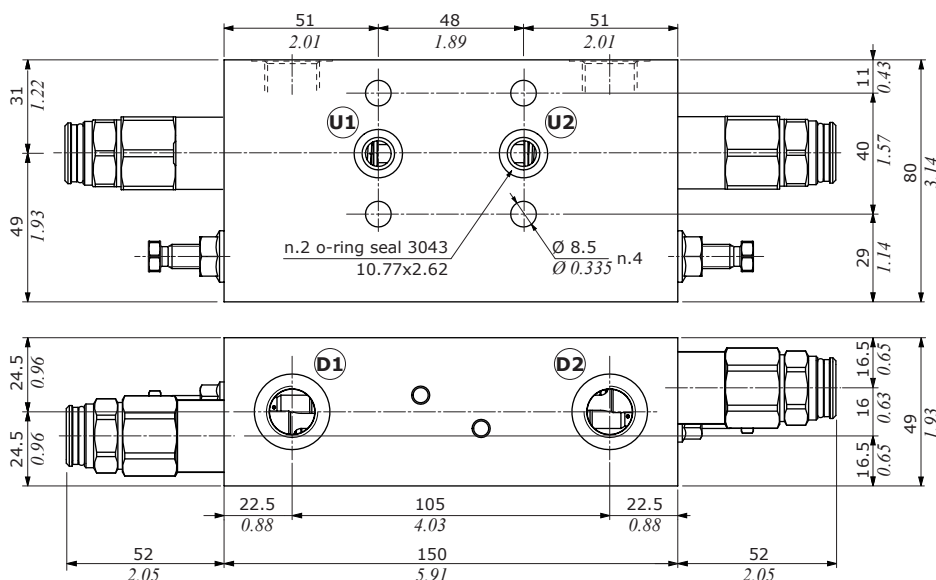

Valve type	D1	D2	U1	U2	M1	M2
VODL/V1116/CS/38	G3/8	G3/8	G3/8	G3/8	G1/4	G1/4
VODL/V1116/CS/12	G1/2	G1/2	G1/2	G1/2	G1/4	G1/4
VODL/V1116/CS/38F2	G3/8	G3/8	Ø8.5 - Ø0.335	Ø8.5 - Ø0.335	-	-
VODL/V1116/CS/12F2	G1/2	G1/2	Ø8.5 - Ø0.335	Ø8.5 - Ø0.335	-	-

Valve type	D1	D2	U1	U2	M1	M2
VODL/V1116/CS/S8	SAE8	SAE8	SAE8	SAE8	G1/4	G1/4
VODL/V1116/CS/S10	SAE10	SAE10	SAE10	SAE10	G1/4	G1/4
VODL/V1116/CS/S8F2	SAE8	SAE8	Ø8.5 - Ø0.335	Ø8.5 - Ø0.335	-	-
VODL/V1116/CS/S10F2	SAE10	SAE10	Ø8.5 - Ø0.335	Ø8.5 - Ø0.335	-	-

Ordering codes and description composition

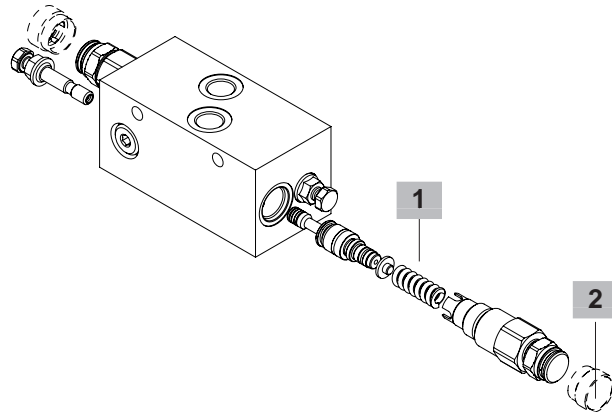
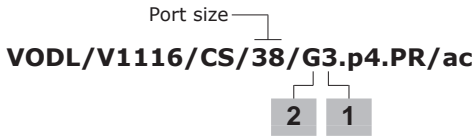

Complete valves

Vented (V) configuration with G3/8 thread

Pilot ratio 1:4

TYPE: **VODL/V1116/CS/38/G3.p4.PR/ac** CODE: 1554522102
DESCRIPTION: Steel body, range 5-210 bar (72.5-3050 psi), std setting 150 bar (2175 psi) @ 5 l/min (1.32 US gpm)

TYPE: **VODL/V1116/CS/38/G5.p4.PR/ac** CODE: 1554522100
DESCRIPTION: Steel body, range 50-350 bar (725-5075 psi), std setting 280 bar (4060 psi) @ 5 l/min (1.32 US gpm)

Pilot ratio 1:8

TYPE: **VODL/V1116/CS/38/G5.p8.PR/ac** CODE: 1554522105
DESCRIPTION: Steel body, range 5-350 bar (72.5-5075 psi), std setting 280 bar (4060 psi) @ 5 l/min (1.32 US gpm)

Zero differential pilot ratio

TYPE: **VODL/V1116/CS/38/G3.p0.PR/ac** CODE: 1554522107
DESCRIPTION: Steel body, range 5-210 bar (72.5-3050 psi), std setting 150 bar (2175 psi) @ 5 l/min (1.32 US gpm)

TYPE: **VODL/V1116/CS/38/G5.p0.PR/ac** CODE: 1554522101
DESCRIPTION: Steel body, range 50-350 bar (725-5075 psi), std setting 280 bar (4060 psi) @ 5 l/min (1.32 US gpm)

Vented (V) configuration with G3/8 thread and F2 flange

TYPE: **VODL/V1116/CS/38F2/G5.p4.PR/ac** CODE: 1556022100
DESCRIPTION: Steel body, pilot ratio 1:4, range 50-350 bar (725-5075 psi), std setting 280 bar (4060 psi) @ 5 min (1.32 US gpm)

TYPE: **VODL/V1116/CS/38F2/G5.p8.PR/ac** CODE: 1556022101
DESCRIPTION: Steel body, pilot ratio 1:8, range 5-350 bar (72.5-5075 psi), std setting 280 bar (4060 psi) @ 5 l/min (1.32 US gpm)

TYPE: **VODL/V1116/CS/38F2/G5.p0.PR/ac** CODE: 1556022102
DESCRIPTION: Steel body, zero differential pilot ratio, range 50-350 bar (725-5075 psi), std setting 280 bar (4060 psi) @ 5 l/min (1.32 US gpm)

Complete valves

Vented (V) configuration with SAE8 thread

Pilot ratio 1:4

TYPE: **VODL/V1116/CS/S8/G3.p4.PR/ac** CODE: 1554522200
DESCRIPTION: Steel body, range 5-210 bar (72.5-3050 psi), std setting 150 bar (2175 psi) @ 5 l/min (1.32 US gpm)

TYPE: **VODL/V1116/CS/S8/G5.p4.PR/ac** CODE: 1554522201
DESCRIPTION: Steel body, range 50-350 bar (725-5075 psi), std setting 280 bar (4060 psi) @ 5 l/min (1.32 US gpm)

Pilot ratio 1:8

TYPE: **VODL/V1116/CS/S8/G5.p8.PR/ac** CODE: 1554522204
DESCRIPTION: Steel body, range 5-350 bar (72.5-5075 psi), std setting 280 bar (4060 psi) @ 5 l/min (1.32 US gpm)

Zero differential pilot ratio

TYPE: **VODL/V1116/CS/S8/G3.p0.PR/ac** CODE: 1554522206
DESCRIPTION: Steel body, range 5-210 bar (72.5-3050 psi), std setting 150 bar (2175 psi) @ 5 l/min (1.32 US gpm)

TYPE: **VODL/V1116/CS/S8/G5.p0.PR/ac** CODE: 1554522207
DESCRIPTION: Steel body, range 50-350 bar (725-5075 psi), std setting 280 bar (4060 psi) @ 5 l/min (1.32 US gpm)

Vented (V) configuration with SAE8 thread and F2 flange

TYPE: **VODL/V1116/CS/S8F2/G5.p4.PR/ac** CODE: 1556022200
DESCRIPTION: Steel body, pilot ratio 1:4, range 50-350 bar (725-5075 psi), std setting 280 bar (4060 psi) @ 5 min (1.32 US gpm)

TYPE: **VODL/V1116/CS/S8F2/G5.p8.PR/ac** CODE: 1556022201
DESCRIPTION: Steel body, pilot ratio 1:8, range 5-350 bar (72.5-5075 psi), std setting 280 bar (4060 psi) @ 5 l/min (1.32 US gpm)

TYPE: **VODL/V1116/CS/S8F2/G5.p0.PR/ac** CODE: 1556022202
DESCRIPTION: Steel body, zero differential pilot ratio, range 50-350 bar (725-5075 psi), std setting 280 bar (4060 psi) @ 5 l/min (1.32 US gpm)

1 Pressure setting spring

TYPE CODE DESCRIPTION

For 1:4 and zero differential pilot ratio

3 3ML1133201 For range 5-210 bar (72.5-3050 psi)
5 3ML1133200 For range 50-350 bar (725-5075 psi)

For 1:8 pilot ratio

5 3ML1133201 For range 5-350 bar (72.5-5075 psi)

2 Setting type

TYPE CODE DESCRIPTION

G - Screw setting
Z 4COP130200 Antitampering cap

Rating diagrams

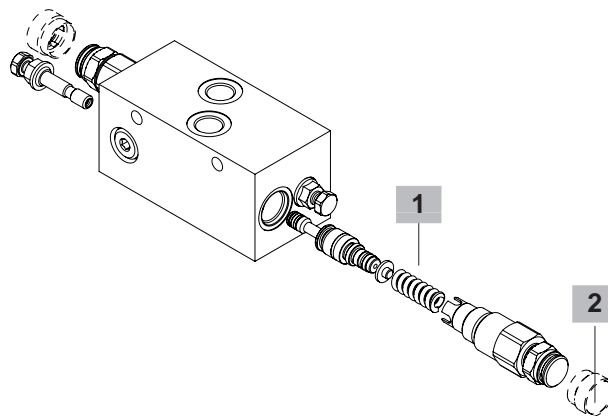
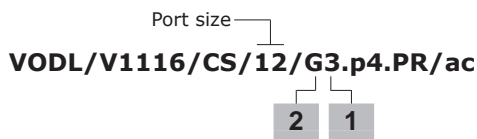

Complete valves

Vented (V) configuration with G1/2 thread

TYPE: **VODL/V1116/CS/12/G5.p4.PR/ac** CODE: 1554532100
DESCRIPTION: Steel body, pilot ratio 1:4, range 50-350 bar (725-5075 psi), std setting 280 bar (4060 psi) @ 5 l/min (1.32 US gpm)

TYPE: **VODL/V1116/CS/12/G5.p8.PR/ac** CODE: 1554532101
DESCRIPTION: Steel body, pilot ratio 1:8, range 5-350 bar (72.5-5075 psi), std setting 280 bar (4060 psi) @ 5 l/min (1.32 US gpm)

TYPE: **VODL/V1116/CS/12/G5.p0/ac** CODE: 1554532102
DESCRIPTION: Steel body, zero differential pilot ratio, range 50-350 bar (725-5075 psi), std setting 280 bar (4060 psi) @ 5 l/min (1.32 US gpm)

Vented (V) configuration with G1/2 thread and F2 flange

TYPE: **VODL/V1116/CS/12F2/G5.p4.PR/ac** CODE: 1556032100
DESCRIPTION: Steel body, pilot ratio 1:4, range 50-350 bar (725-5075 psi), std setting 280 bar (4060 psi) @ 5 l/min (1.32 US gpm)

TYPE: **VODL/V1116/CS/12F2/G5.p8.PR/ac** CODE: 1556032101
DESCRIPTION: Steel body, pilot ratio 1:8, range 5-350 bar (72.5-5075 psi), std setting 280 bar (4060 psi) @ 5 l/min (1.32 US gpm)

TYPE: **VODL/V1116/CS/12F2/G5.p0.PR/ac** CODE: 1556032102
DESCRIPTION: Steel body, zero differential pilot ratio, range 50-350 bar (725-5075 psi), std setting 280 bar (4060 psi) @ 5 l/min (1.32 US gpm)

For other configurations please contact our Sales Dpt.

Vented (V) configuration with SAE10 thread

TYPE: **VODL/V1116/CS/S10/G5.p4.PR/ac** CODE: 1554532200
DESCRIPTION: Steel body, pilot ratio 1:4, range 50-350 bar (725-5075 psi), std setting 280 bar (4060 psi) @ 5 l/min (1.32 US gpm)

TYPE: **VODL/V1116/CS/S10/G5.p8.PR/ac** CODE: 1554532201
DESCRIPTION: Steel body, pilot ratio 1:8, range 5-350 bar (72.5-5075 psi), std setting 280 bar (4060 psi) @ 5 l/min (1.32 US gpm)

TYPE: **VODL/V1116/CS/S10/G5.p0/ac** CODE: 1554532202
DESCRIPTION: Steel body, zero differential pilot ratio, range 50-350 bar (725-5075 psi), std setting 280 bar (4060 psi) @ 5 l/min (1.32 US gpm)

Complete valves

Vented (V) configuration with SAE10 thread and F2 flange

TYPE: **VODL/V1116/CS/S10F2/G5.p4.PR/ac** CODE: 1556032200
DESCRIPTION: Steel body, pilot ratio 1:4, range 50-350 bar (725-5075 psi), std setting 280 bar (4060 psi) @ 5 l/min (1.32 US gpm)

TYPE: **VODL/V1116/CS/S10F2/G5.p8.PR/ac** CODE: 1556032201
DESCRIPTION: Steel body, pilot ratio 1:8, range 5-350 bar (72.5-5075 psi), std setting 280 bar (4060 psi) @ 5 l/min (1.32 US gpm)

TYPE: **VODL/V1116/CS/S10F2/G5.p0.PR/ac** CODE: 1556032202
DESCRIPTION: Steel body, zero differential pilot ratio, range 50-350 bar (725-5075 psi), std setting 280 bar (4060 psi) @ 5 l/min (1.32 US gpm)

For other configurations please contact our Sales Dpt.

1 Pressure setting spring

TYPE	CODE	DESCRIPTION
3	3ML1133201	For range 5-210 bar (72.5-3050 psi)
5	3ML1133200	For range 50-350 bar (725-5075 psi)
5	3ML1133201	For range 5-350 bar (72.5-5075 psi)

For 1:4 and zero differential pilot ratio

3 3ML1133201 For range 5-210 bar (72.5-3050 psi)

5 3ML1133200 For range 50-350 bar (725-5075 psi)

For 1:8 pilot ratio

5 3ML1133201 For range 5-350 bar (72.5-5075 psi)

2 Setting type

TYPE	CODE	DESCRIPTION
G	-	Screw setting
Z	4COP130200	Antitampering cap

Rating diagrams

VODL/V/1116/CS pressure drop vs. flow from D1->U1 and U1 to D1 (D2->U2 and U2 to D2)

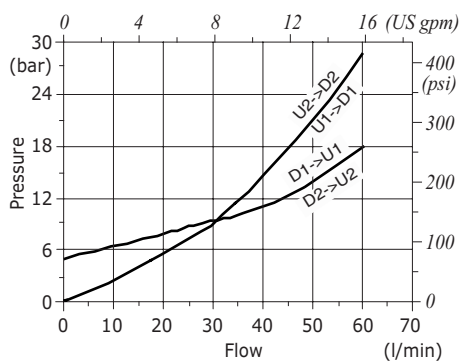

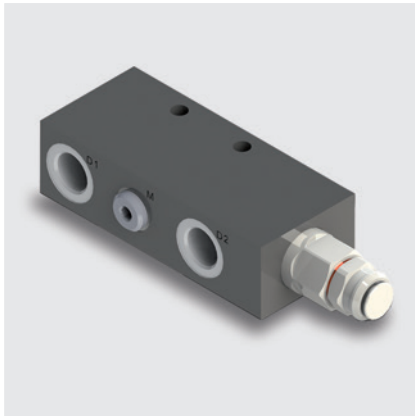

Type VOSL/N1516 - VOSL/V1516 counterbalance valves

- Single acting
- Load Sensitive (type N)
- Vented (type V)
- Configuration with F1 and F2 flange

Technical specifications and diagrams are measured with mineral oil of 46 cSt viscosity at 40°C (104°F) temperature.

VOSL/N1516 (12-34) - VOSL/V1516 (12-34)

Nominal flow	160 l/min (42.3 US gpm)
Max. pressure	350 bar ⁽¹⁾ (5100 psi) - 400 bar ⁽²⁾ (5800 psi)
Oil leakage	0.5 cm ³ /min (0.030 in ³ /min) - 10 drops/min at 80% of pressure setting
Fluid	mineral based oil
Viscosity	from 10 to 200 cSt
Max. level of contamination	18/16/13 ISO4406
Fluid temperature	with NBR seals from -20°C (-4°F) to 90°C (194°F)
Environmental temp. for working conditions	from -20°C (-4°F) to 50°C (122°F)

Weight

VOSL/N1516/12: 2.50 kg (5.51 lb) - **VOSL/N1516/34:** 3.30 kg (7.27 lb)

VOSL/V1516/12: 2.50 kg (5.51 lb) - **VOSL/V1516/34:** 3.30 kg (7.27 lb)

NOTE - For different conditions, please contact Walvoil Sales Dpt. - ⁽¹⁾According to NFPA T 2.6.1., fatigue rating verified for 1 million cycles on 6 sample valves with test Pressure = 1.23 x Max. pressure indicated - ⁽²⁾Intermittent pressure at max. 100,000 cycles with specific internal testing.

VOSL/N1516

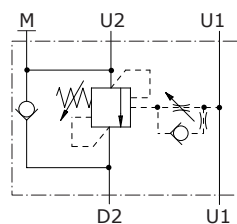

VOSL/V1516

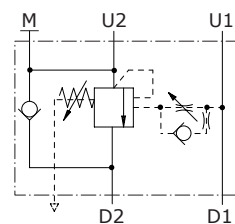

VOSL/N1516/F1

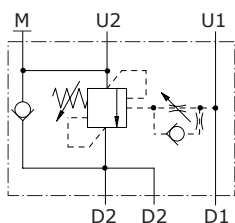

VOSL/V1516/F1

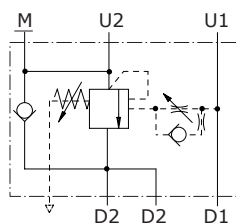

VOSL/N1516/F2

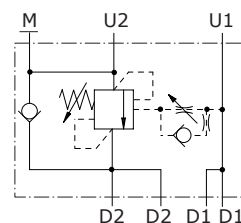

VOSL/V1516/F2

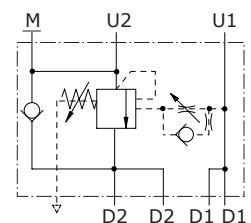

Dimensions

VOSL/...1516/12 - VOSL/...1516/34

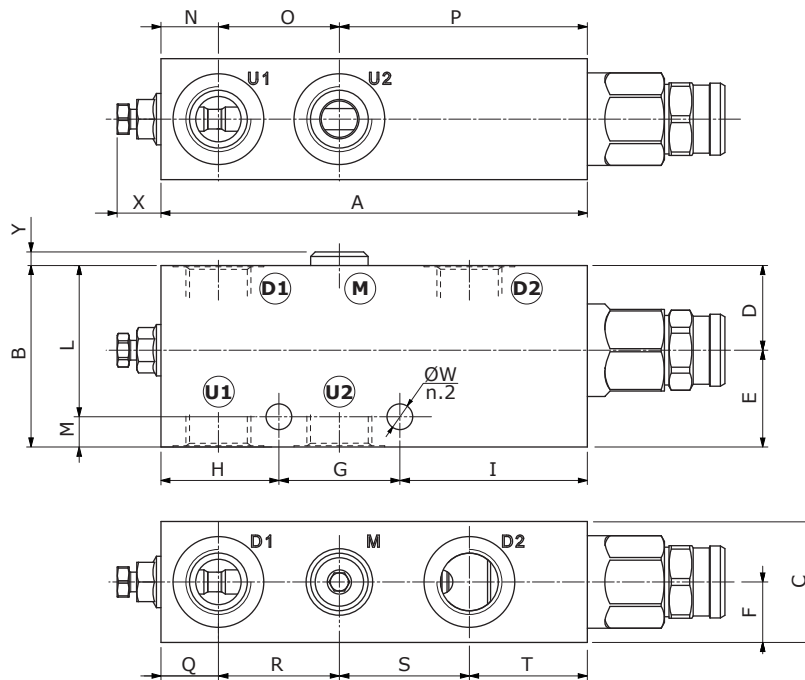

VOSL/...1516/12F1 - VOSL/...1516/34F1

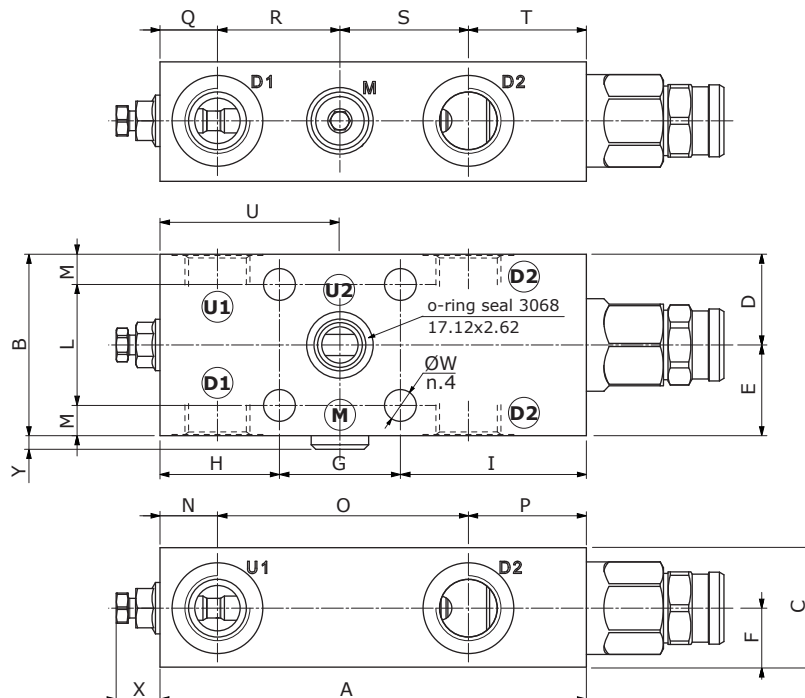

VOSL/...1516/12F2 - VOSL/...1516/34F2

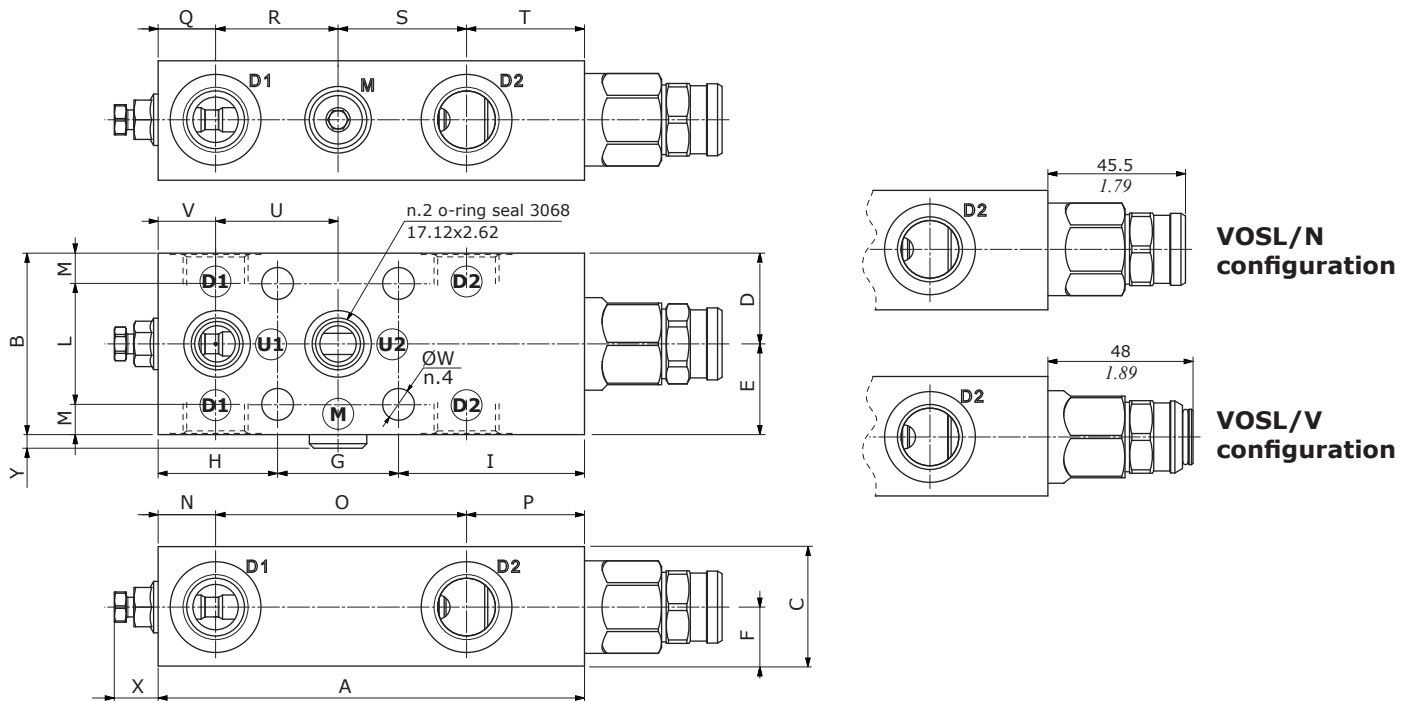

Valve type	D1	D2	U1	U2	M	Valve type	D1	D2	U1	U2	M
VOSL/...1516/12	G1/2	G1/2	G1/2	G1/2	G1/4	VOSL/...1516/S10	SAE10	SAE10	SAE10	SAE10	G1/4
VOSL/...1516/34	G3/4	G3/4	G3/4	G3/4	G1/4	VOSL/...1516/S12	SAE12	SAE12	SAE12	SAE12	G1/4
VOSL/...1516/12F1	G1/2	G1/2	G1/2	Ø12-Ø0.472	G1/4	VOSL/...1516/S10F1	SAE10	SAE10	SAE10	Ø12-Ø0.472	G1/4
VOSL/...1516/34F1	G3/4	G3/4	G3/4	Ø12-Ø0.472	G1/4	VOSL/...1516/S12F1	SAE12	SAE12	SAE12	Ø12-Ø0.472	G1/4
VOSL/...1516/12F2	G1/2	G1/2	Ø12-Ø0.472	Ø12-Ø0.472	G1/4	VOSL/...1516/S10F2	SAE10	SAE10	Ø12-Ø0.472	Ø12-Ø0.472	G1/4
VOSL/...1516/34F2	G3/4	G3/4	Ø12-Ø0.472	Ø12-Ø0.472	G1/4	VOSL/...1516/S12F2	SAE12	SAE12	Ø12-Ø0.472	Ø12-Ø0.472	G1/4

Dimensions are in mm-in

Valve type	A	B	C	D	E	F	G	H	I	L	M	N
VOSL/...1516/12 VOSL/...1516/S10	141-5.55	60-2.36	40-1.57	28-1.10	32-1.26	20-0.79	40-1.57	39-1.54	62-2.44	50-1.97	10-0.394	19-0.75
VOSL/...1516/34 VOSL/...1516/S12	147-5.79	80-3.15	40-1.57	39-1.54	41-1.61	20-0.79	40-1.57	45-1.77	62-2.44	60-2.36	20-0.79	22-0.87
VOSL/...1516/12F1 VOSL/...1516/S10F1	141-5.55	60-2.36	39.5-1.56	30-1.18	30-1.18	19.5-0.77	40-1.57	39.5-1.56	61.5-2.42	40-1.57	10-0.394	19-0.75
VOSL/...1516/34F1 VOSL/...1516/S12F1	147-5.79	80-3.15	39.5-1.56	40-1.57	40-1.57	19.5-0.77	40-1.57	45-1.77	62-2.44	40-1.57	20-0.79	22-0.87
VOSL/...1516/12F2 VOSL/...1516/S10F2	141-5.55	60-2.36	39.5-1.56	30-1.18	30-1.18	19.5-0.77	40-1.57	39.5-1.56	61.5-2.42	40-1.57	10-0.394	19-0.75
VOSL/...1516/34F2 VOSL/...1516/S12F2	147-5.79	80-3.15	39.5-1.56	40-1.57	40-1.57	19.5-0.77	40-1.57	45-1.77	62-2.44	40-1.57	20-0.79	22-0.87

Valve type	O	P	Q	R	S	T	U	V	ØW	X(max)	Y
VOSL/...1516/12 VOSL/...1516/S10	40-1.57	82-3.23	19-0.75	40-1.57	43-1.69	39-1.54	-	-	8.5-0.335	22-0.87	4.5-0.177
VOSL/...1516/34 VOSL/...1516/S12	43-1.69	65-2.56	22-0.87	43-1.69	43-1.69	39-1.54	-	-	10.5-0.413	22-0.87	4.5-0.177
VOSL/...1516/12F1 VOSL/...1516/S10	83-3.27	39-1.54	19-0.75	40.5-1.59	42.5-1.67	39-1.54	59.5-2.34	-	10.5-0.413	22-0.87	4.5-0.177
VOSL/...1516/34F1 VOSL/...1516/S12F1	86-3.39	39-1.54	22-0.87	43-1.69	43-1.69	39-1.54	65-2.56	-	10.5-0.413	22-0.87	4.5-0.177
VOSL/...1516/12F2 VOSL/...1516/S10F2	83-3.27	39-1.54	19-0.75	40.5-1.59	42.5-1.67	39-1.54	40-1.57	19.5-0.77	10.5-0.413	22-0.87	4.5-0.177
VOSL/...1516/34F2 VOSL/...1516/S12F2	86-3.39	39-1.54	22-0.87	43-1.69	43-1.69	39-1.54	43-1.69	22-0.87	10.5-0.413	22-0.87	4.5-0.177

Ordering codes and description composition

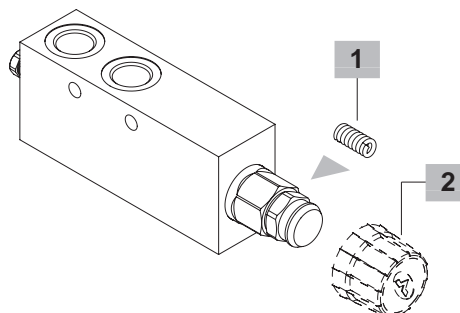
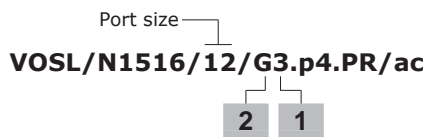

VOSL/N1516 Complete valves

Load sensitive (N) configuration with G1/2 thread

Pilot ratio 1:4

TYPE: **VOSL/N1516/12/G3.p4.PR/ac** CODE: 1514632100
DESCRIPTION: Steel body, range 50-210 bar (725-3050 psi), std setting 150 bar (2175 psi) @ 5 l/min (1.32 US gpm)

TYPE: **VOSL/N1516/12/G5.p4.PR/ac** CODE: 1514632101
DESCRIPTION: Steel body, range 50-350 bar (725-5075 psi), std setting 280 bar (4060 psi) @ 5 l/min (1.32 US gpm)

TYPE: **VOSL/N1516/12/G7.p4.PR/ac** CODE: 1514632102
DESCRIPTION: Steel body, range 150-400 bar (2175-5800 psi), std setting 350 bar (5075 psi) @ 5 l/min (1.32 US gpm)

Pilot ratio 1:8

TYPE: **VOSL/N1516/12/G5.p8.PR/ac** CODE: 1514632104
DESCRIPTION: Steel body, range 50-350 bar (725-5075 psi), std setting 280 bar (4060 psi) @ 5 l/min (1.32 US gpm)

TYPE: **VOSL/N1516/12/G7.p8.PR/ac** CODE: 1514632105
DESCRIPTION: Steel body, range 150-400 bar (2175-5800 psi), std setting 350 bar (5075 psi) @ 5 l/min (1.32 US gpm)

Zero differential pilot ratio

TYPE: **VOSL/N1516/12/G3.p0.PR/ac** CODE: 1514632106
DESCRIPTION: Steel body, range 50-210 bar (725-3050 psi), std setting 150 bar (2175 psi) @ 5 l/min (1.32 US gpm)

TYPE: **VOSL/N1516/12/G5.p0.PR/ac** CODE: 1514632107
DESCRIPTION: Steel body, range 50-350 bar (725-5075 psi), std setting 280 bar (4060 psi) @ 5 l/min (1.32 US gpm)

TYPE: **VOSL/N1516/12/G7.p0.PR/ac** CODE: 1514632108
DESCRIPTION: Steel body, range 150-400 bar (2175-5800 psi), std setting 350 bar (5075 psi) @ 5 l/min (1.32 US gpm)

Load sensitive (N) configuration with G1/2 thread and F1 flange

TYPE: **VOSL/N1516/12F1/G5.p4.PR/ac** CODE: 1515632100
DESCRIPTION: Steel body, pilot ratio 1:4, range 50-350 bar (725-5075 psi), std setting 280 bar (4060 psi) @ 5 l/min (1.32 US gpm)

TYPE: **VOSL/N1516/12F1/G5.p8.PR/ac** CODE: 1515632101
DESCRIPTION: Steel body, pilot ratio 1:8, range 50-350 bar (725-5075 psi), std setting 280 bar (4060 psi) @ 5 l/min (1.32 US gpm)

TYPE: **VOSL/N1516/12F1/G5.p0.PR/ac** CODE: 1515632102
DESCRIPTION: Steel body, zero differential pilot ratio, range 50-350 bar (725-5075 psi), std setting 280 bar (4060 psi) @ 5 l/min (1.32 US gpm)

Load sensitive (N) configuration with G1/2 thread and F2 flange

TYPE: **VOSL/N1516/12F2/G5.p4.PR/ac** CODE: 1515632103
DESCRIPTION: Steel body, pilot ratio 1:4, range 50-350 bar (725-5075 psi), std setting 280 bar (4060 psi) @ 5 l/min (1.32 US gpm)

TYPE: **VOSL/N1516/12F2/G5.p8.PR/ac** CODE: 1515632104
DESCRIPTION: Steel body, pilot ratio 1:8, range 50-350 bar (725-5075 psi), std setting 280 bar (4060 psi) @ 5 l/min (1.32 US gpm)

TYPE: **VOSL/N1516/12F2/G5.p0.PR/ac** CODE: 1515632105
DESCRIPTION: Steel body, zero differential pilot ratio, range 50-350 bar (725-5075 psi), std setting 280 bar (4060 psi) @ 5 l/min (1.32 US gpm)

VOSL/N1516 Complete valves

Load sensitive (N) configuration with SAE10 thread

Pilot ratio 1:4

TYPE: **VOSL/N1516/S10/G3.p4.PR/ac** CODE: 1514632200
DESCRIPTION: Steel body, range 50-210 bar (725-3050 psi), std setting 150 bar (2175 psi) @ 5 l/min (1.32 US gpm)

TYPE: **VOSL/N1516/S10/G5.p4.PR/ac** CODE: 1514632201
DESCRIPTION: Steel body, range 50-350 bar (725-5075 psi), std setting 280 bar (4060 psi) @ 5 l/min (1.32 US gpm)

TYPE: **VOSL/N1516/S10/G7.p4.PR/ac** CODE: 1514632202
DESCRIPTION: Steel body, range 150-400 bar (2175-5800 psi), std setting 350 bar (5075 psi) @ 5 l/min (1.32 US gpm)

Pilot ratio 1:8

TYPE: **VOSL/N1516/S10/G5.p8.PR/ac** CODE: 1514632204
DESCRIPTION: Steel body, range 50-350 bar (725-5075 psi), std setting 280 bar (4060 psi) @ 5 l/min (1.32 US gpm)

TYPE: **VOSL/N1516/S10/G7.p8.PR/ac** CODE: 1514632205
DESCRIPTION: Steel body, range 150-400 bar (2175-5800 psi), std setting 350 bar (5075 psi) @ 5 l/min (1.32 US gpm)

Zero differential pilot ratio

TYPE: **VOSL/N1516/S10/G3.p0.PR/ac** CODE: 1514632206
DESCRIPTION: Steel body, range 50-210 bar (725-3050 psi), std setting 150 bar (2175 psi) @ 5 l/min (1.32 US gpm)

TYPE: **VOSL/N1516/S10/G5.p0.PR/ac** CODE: 1514632207
DESCRIPTION: Steel body, range 50-350 bar (725-5075 psi), std setting 280 bar (4060 psi) @ 5 l/min (1.32 US gpm)

TYPE: **VOSL/N1516/S10/G7.p0.PR/ac** CODE: 1514632208
DESCRIPTION: Steel body, range 150-400 bar (2175-5800 psi), std setting 350 bar (5075 psi) @ 5 l/min (1.32 US gpm)

Load sensitive (N) configuration with SAE10 thread and F1 flange

TYPE: **VOSL/N1516/S10F1/G5.p4.PR/ac** CODE: 1515632200
DESCRIPTION: Steel body, pilot ratio 1:4, range 50-350 bar (725-5075 psi), std setting 280 bar (4060 psi) @ 5 l/min (1.32 US gpm)

TYPE: **VOSL/N1516/S10F1/G5.p8.PR/ac** CODE: 1515632201
DESCRIPTION: Steel body, pilot ratio 1:8, range 50-350 bar (725-5075 psi), std setting 280 bar (4060 psi) @ 5 l/min (1.32 US gpm)

TYPE: **VOSL/N1516/S10F1/G5.p0.PR/ac** CODE: 1515632202
DESCRIPTION: Steel body, zero differential pilot ratio, range 50-350 bar (725-5075 psi), std setting 280 bar (4060 psi) @ 5 l/min (1.32 US gpm)

Load sensitive (N) configuration with SAE10 thread and F2 flange

TYPE: **VOSL/N1516/S10F2/G5.p4.PR/ac** CODE: 1515632203
DESCRIPTION: Steel body, pilot ratio 1:4, range 50-350 bar (725-5075 psi), std setting 280 bar (4060 psi) @ 5 l/min (1.32 US gpm)

TYPE: **VOSL/N1516/S10F2/G5.p8.PR/ac** CODE: 1515632204
DESCRIPTION: Steel body, pilot ratio 1:8, range 50-350 bar (725-5075 psi), std setting 280 bar (4060 psi) @ 5 l/min (1.32 US gpm)

TYPE: **VOSL/N1516/S10F2/G5.p0.PR/ac** CODE: 1515632205
DESCRIPTION: Steel body, zero differential pilot ratio, range 50-350 bar (725-5075 psi), std setting 280 bar (4060 psi) @ 5 l/min (1.32 US gpm)

Ordering codes and description composition

VOSL/N1516 Complete valves

Load sensitive (N) configuration with G3/4 thread

TYPE: **VOSL/N1516/34/G5.p4.PR/ac** CODE: 1514642100
DESCRIPTION: Steel body, pilot ratio 1:4, range 50-350 bar (725-5075 psi), std setting 280 bar (4060 psi) @ 5 l/min (1.32 US gpm)

TYPE: **VOSL/N1516/34/G5.p8.PR/ac** CODE: 1514642101
DESCRIPTION: Steel body, pilot ratio 1:8, range 50-350 bar (725-5075 psi), std setting 280 bar (4060 psi) @ 5 l/min (1.32 US gpm)

TYPE: **VOSL/N1516/34/G5.p0.PR/ac** CODE: 1514642102
DESCRIPTION: Steel body, zero differential pilot ratio, range 50-350 bar (725-5075 psi), std setting 280 bar (4060 psi) @ 5 l/min (1.32 US gpm)

Load sensitive (N) configuration with G3/4 thread and F1 flange

TYPE: **VOSL/N1516/34F1/G5.p4.PR/ac** CODE: 1515642100
DESCRIPTION: Steel body, pilot ratio 1:4, range 50-350 bar (725-5075 psi), std setting 280 bar (4060 psi) @ 5 l/min (1.32 US gpm)

TYPE: **VOSL/N1516/34F1/G5.p8.PR/ac** CODE: 1515642101
DESCRIPTION: Steel body, pilot ratio 1:8, range 50-350 bar (725-5075 psi), std setting 280 bar (4060 psi) @ 5 l/min (1.32 US gpm)

TYPE: **VOSL/N1516/34F1/G5.p0.PR/ac** CODE: 1515642102
DESCRIPTION: Steel body, zero differential pilot ratio, range 50-350 bar (725-5075 psi), std setting 280 bar (4060 psi) @ 5 l/min (1.32 US gpm)

Load sensitive (N) configuration with G3/4 thread and F2 flange

TYPE: **VOSL/N1516/34F2/G5.p4.PR/ac** CODE: 1515642103
DESCRIPTION: Steel body, pilot ratio 1:4, range 50-350 bar (725-5075 psi), std setting 280 bar (4060 psi) @ 5 l/min (1.32 US gpm)

TYPE: **VOSL/N1516/34F2/G5.p8.PR/ac** CODE: 1515642104
DESCRIPTION: Steel body, pilot ratio 1:8, range 50-350 bar (725-5075 psi), std setting 280 bar (4060 psi) @ 5 l/min (1.32 US gpm)

TYPE: **VOSL/N1516/34F2/G5.p0.PR/ac** CODE: 1515642105
DESCRIPTION: Steel body, zero differential pilot ratio, range 50-350 bar (725-5075 psi), std setting 280 bar (4060 psi) @ 5 l/min (1.32 US gpm)

For other configurations please contact our Sales Dpt.

VOSL/N1516 Complete valves

Load sensitive (N) configuration with SAE12 thread

TYPE: **VOSL/N1516/S12/G5.p4.PR/ac** CODE: 1514642200
DESCRIPTION: Steel body, pilot ratio 1:4, range 50-350 bar (725-5075 psi), std setting 280 bar (4060 psi) @ 5 l/min (1.32 US gpm)

TYPE: **VOSL/N1516/S12/G5.p8.PR/ac** CODE: 1514642201
DESCRIPTION: Steel body, pilot ratio 1:8, range 50-350 bar (725-5075 psi), std setting 280 bar (4060 psi) @ 5 l/min (1.32 US gpm)

TYPE: **VOSL/N1516/S12/G5.p0.PR/ac** CODE: 1514642202
DESCRIPTION: Steel body, zero differential pilot ratio, range 50-350 bar (725-5075 psi), std setting 280 bar (4060 psi) @ 5 l/min (1.32 US gpm)

Load sensitive (N) configuration with SAE12 thread and F1 flange

TYPE: **VOSL/N1516/S12F1/G5.p4.PR/ac** CODE: 1515642200
DESCRIPTION: Steel body, pilot ratio 1:4, range 50-350 bar (725-5075 psi), std setting 280 bar (4060 psi) @ 5 l/min (1.32 US gpm)

TYPE: **VOSL/N1516/S12F1/G5.p8.PR/ac** CODE: 1515642201
DESCRIPTION: Steel body, pilot ratio 1:8, range 50-350 bar (725-5075 psi), std setting 280 bar (4060 psi) @ 5 l/min (1.32 US gpm)

TYPE: **VOSL/N1516/S12F1/G5.p0.PR/ac** CODE: 1515642202
DESCRIPTION: Steel body, zero differential pilot ratio, range 50-350 bar (725-5075 psi), std setting 280 bar (4060 psi) @ 5 l/min (1.32 US gpm)

Load sensitive (N) configuration with SAE12 thread and F2 flange

TYPE: **VOSL/N1516/S12F2/G5.p4.PR/ac** CODE: 1515642203
DESCRIPTION: Steel body, pilot ratio 1:4, range 50-350 bar (725-5075 psi), std setting 280 bar (4060 psi) @ 5 l/min (1.32 US gpm)

TYPE: **VOSL/N1516/S12F2/G5.p8.PR/ac** CODE: 1515642204
DESCRIPTION: Steel body, pilot ratio 1:8, range 50-350 bar (725-5075 psi), std setting 280 bar (4060 psi) @ 5 l/min (1.32 US gpm)

TYPE: **VOSL/N1516/S12F2/G5.p0.PR/ac** CODE: 1515642205
DESCRIPTION: Steel body, zero differential pilot ratio, range 50-350 bar (725-5075 psi), std setting 280 bar (4060 psi) @ 5 l/min (1.32 US gpm)

For other configurations please contact our Sales Dpt.

1 Pressure setting spring

TYPE	CODE	DESCRIPTION
For 1:4 and zero differential pilot ratio		
3	3MOL316450	For range 50-210 bar (725-3050 psi)
5	3MOL316430	For range 50-350 bar (725-5075 psi)
7	3MOL316411	For range 150-400 bar (2175-5800 psi)
For 1:8 pilot ratio		
5	3MOL316450	For range 50-350 bar (725-5075 psi)
7	3MOL316430	For range 150-400 bar (2175-5800 psi)

2 Antitampering cap

TYPE	CODE	DESCRIPTION
G	-	Screw setting
Z	4COP140311	Antitampering cap

Ordering codes and description composition

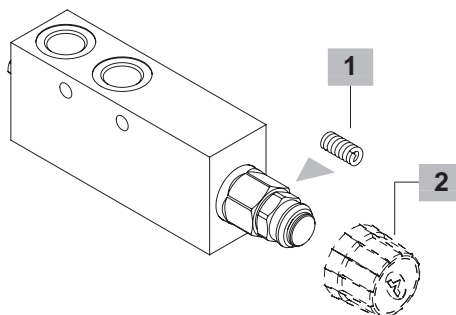
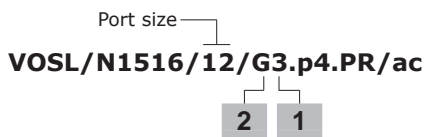

VOSL/V1516 Complete valves

Vented (V) configuration with G1/2 thread

Pilot ratio 1:4

TYPE: **VOSL/V1516/12/G3.p4.PR/ac** CODE: 1514732100
DESCRIPTION: Steel body, range 50-210 bar (72.5-3050 psi), std setting 150 bar (2175 psi) @ 5 l/min (1.32 US gpm)

TYPE: **VOSL/V1516/12/G5.p4.PR/ac** CODE: 1514732101
DESCRIPTION: Steel body, range 50-350 bar (72.5-5075 psi), std setting 280 bar (4060 psi) @ 5 l/min (1.32 US gpm)

TYPE: **VOSL/V1516/12/G7.p4.PR/ac** CODE: 1514732102
DESCRIPTION: Steel body, range 150-400 bar (2175-5800 psi), std setting 350 bar (5075 psi) @ 5 l/min (1.32 US gpm)

Pilot ratio 1:8

TYPE: **VOSL/V1516/12/G5.p8.PR/ac** CODE: 1514732104
DESCRIPTION: Steel body, range 50-350 bar (72.5-5075 psi), std setting 280 bar (4060 psi) @ 5 l/min (1.32 US gpm)

TYPE: **VOSL/V1516/12/G7.p8.PR/ac** CODE: 1514732105
DESCRIPTION: Steel body, range 150-400 bar (2175-5800 psi), std setting 350 bar (5075 psi) @ 5 l/min (1.32 US gpm)

Zero differential pilot ratio

TYPE: **VOSL/V1516/12/G3.p0.PR/ac** CODE: 1514732106
DESCRIPTION: Steel body, range 50-210 bar (72.5-3050 psi), std setting 150 bar (2175 psi) @ 5 l/min (1.32 US gpm)

TYPE: **VOSL/V1516/12/G5.p0.PR/ac** CODE: 1514732107
DESCRIPTION: Steel body, range 50-350 bar (72.5-5075 psi), std setting 280 bar (4060 psi) @ 5 l/min (1.32 US gpm)

TYPE: **VOSL/V1516/12/G7.p0.PR/ac** CODE: 1514732108
DESCRIPTION: Steel body, range 150-400 bar (2175-5800 psi), std setting 350 bar (5075 psi) @ 5 l/min (1.32 US gpm)

Vented (V) configuration with G1/2 thread and F1 flange

TYPE: **VOSL/V1516/12F1/G5.p4.PR/ac** CODE: 1515732100
DESCRIPTION: Steel body, pilot ratio 1:4, range 50-350 bar (72.5-5075 psi), std setting 280 bar (4060 psi) @ 5 l/min (1.32 US gpm)

TYPE: **VOSL/V1516/12F1/G5.p8.PR/ac** CODE: 1515732101
DESCRIPTION: Steel body, pilot ratio 1:8, range 50-350 bar (72.5-5075 psi), std setting 280 bar (4060 psi) @ 5 l/min (1.32 US gpm)

TYPE: **VOSL/V1516/12F1/G5.p0.PR/ac** CODE: 1515732102
DESCRIPTION: Steel body, zero differential pilot ratio, range 50-350 bar (72.5-5075 psi), std setting 280 bar (4060 psi) @ 5 l/min (1.32 US gpm)

Vented (V) configuration with G1/2 thread and F2 flange

TYPE: **VOSL/V1516/12F2/G5.p4.PR/ac** CODE: 1515732103
DESCRIPTION: Steel body, pilot ratio 1:4, range 50-350 bar (72.5-5075 psi), std setting 280 bar (4060 psi) @ 5 l/min (1.32 US gpm)

TYPE: **VOSL/V1516/12F2/G5.p8.PR/ac** CODE: 1515732104
DESCRIPTION: Steel body, Pilot ratio 1:8, range 50-350 bar (72.5-5075 psi), std setting 280 bar (4060 psi) @ 5 l/min (1.32 US gpm)

TYPE: **VOSL/V1516/12F2/G5.p0.PR/ac** CODE: 1515732105
DESCRIPTION: Steel body, zero differential pilot ratio, range 50-350 bar (72.5-5075 psi), std setting 280 bar (4060 psi) @ 5 l/min (1.32 US gpm)

VOSL/V1516 Complete valves

Vented (V) configuration with SAE10 thread

Pilot ratio 1:4

TYPE: **VOSL/V1516/S10/G3.p4.PR/ac** CODE: 1514732200
DESCRIPTION: Steel body, range 50-210 bar (72.5-3050 psi), std setting 150 bar (2175 psi) @ 5 l/min (1.32 US gpm)

TYPE: **VOSL/V1516/S10/G5.p4.PR/ac** CODE: 1514732201
DESCRIPTION: Steel body, range 50-350 bar (72.5-5075 psi), std setting 280 bar (4060 psi) @ 5 l/min (1.32 US gpm)

TYPE: **VOSL/V1516/S10/G7.p4.PR/ac** CODE: 1514732202
DESCRIPTION: Steel body, range 150-400 bar (2175-5800 psi), std setting 350 bar (5075 psi) @ 5 l/min (1.32 US gpm)

Pilot ratio 1:8

TYPE: **VOSL/V1516/S10/G5.p8.PR/ac** CODE: 1514732204
DESCRIPTION: Steel body, range 50-350 bar (72.5-5075 psi), std setting 280 bar (4060 psi) @ 5 l/min (1.32 US gpm)

TYPE: **VOSL/V1516/S10/G7.p8.PR/ac** CODE: 1514732205
DESCRIPTION: Steel body, range 150-400 bar (2175-5800 psi), std setting 350 bar (5075 psi) @ 5 l/min (1.32 US gpm)

Zero differential pilot ratio

TYPE: **VOSL/V1516/S10/G3.p0.PR/ac** CODE: 1514732206
DESCRIPTION: Steel body, range 50-210 bar (72.5-3050 psi), std setting 150 bar (2175 psi) @ 5 l/min (1.32 US gpm)

TYPE: **VOSL/V1516/S10/G5.p0.PR/ac** CODE: 1514732207
DESCRIPTION: Steel body, range 50-350 bar (72.5-5075 psi), std setting 280 bar (4060 psi) @ 5 l/min (1.32 US gpm)

TYPE: **VOSL/V1516/S10/G7.p0.PR/ac** CODE: 1514732208
DESCRIPTION: Steel body, range 150-400 bar (2175-5800 psi), std setting 350 bar (5075 psi) @ 5 l/min (1.32 US gpm)

Vented (V) configuration with SAE10 thread and F1 flange

TYPE: **VOSL/V1516/S10F1/G5.p4.PR/ac** CODE: 1515732200
DESCRIPTION: Steel body, pilot ratio 1:4, range 50-350 bar (72.5-5075 psi), std setting 280 bar (4060 psi) @ 5 l/min (1.32 US gpm)

TYPE: **VOSL/V1516/S10F1/G5.p8.PR/ac** CODE: 1515732201
DESCRIPTION: Steel body, pilot ratio 1:8, range 50-350 bar (72.5-5075 psi), std setting 280 bar (4060 psi) @ 5 l/min (1.32 US gpm)

TYPE: **VOSL/V1516/S10F1/G5.p0.PR/ac** CODE: 1515732202
DESCRIPTION: Steel body, zero differential pilot ratio, range 50-350 bar (72.5-5075 psi), std setting 280 bar (4060 psi) @ 5 l/min (1.32 US gpm)

Vented (V) configuration with SAE10 thread and F2 flange

TYPE: **VOSL/V1516/S10F2/G5.p4.PR/ac** CODE: 1515732203
DESCRIPTION: Steel body, pilot ratio 1:4, range 50-350 bar (72.5-5075 psi), std setting 280 bar (4060 psi) @ 5 l/min (1.32 US gpm)

TYPE: **VOSL/V1516/S10F2/G5.p8.PR/ac** CODE: 1515732204
DESCRIPTION: Steel body, Pilot ratio 1:8, range 50-350 bar (72.5-5075 psi), std setting 280 bar (4060 psi) @ 5 l/min (1.32 US gpm)

TYPE: **VOSL/V1516/S10F2/G5.p0.PR/ac** CODE: 1515732205
DESCRIPTION: Steel body, zero differential pilot ratio, range 50-350 bar (72.5-5075 psi), std setting 280 bar (4060 psi) @ 5 l/min (1.32 US gpm)

Ordering codes and description composition

VOSL/V1516 Complete valves

Vented (V) configuration with G2/4 thread

TYPE: **VOSL/V1516/34/G5.p4.PR/ac** CODE: 1514742100
DESCRIPTION: Steel body, pilot ratio 1:4, range 50-350 bar (725-5075 psi), std setting 280 bar (4060 psi) @ 5 l/min (1.32 US gpm)
TYPE: **VOSL/V1516/34/G5.p8.PR/ac** CODE: 1514742101
DESCRIPTION: Steel body, pilot ratio 1:8, range 50-350 bar (725-5075 psi), std setting 280 bar (4060 psi) @ 5 l/min (1.32 US gpm)
TYPE: **VOSL/V1516/34/G5.p0.PR/ac** CODE: 1514742102
DESCRIPTION: Steel body, zero differential pilot ratio, range 50-350 bar (725-5075 psi), std setting 280 bar (4060 psi) @ 5 l/min (1.32 US gpm)

Vented (V) configuration with G3/4 thread and F1 flange

TYPE: **VOSL/V1516/34F1/G5.p4.PR/ac** CODE: 1515742100
DESCRIPTION: Steel body, pilot ratio 1:4, range 50-350 bar (725-5075 psi), std setting 280 bar (4060 psi) @ 5 l/min (1.32 US gpm)
TYPE: **VOSL/V1516/34F1/G5.p8.PR/ac** CODE: 1515742101
DESCRIPTION: Steel body, pilot ratio 1:8, range 50-350 bar (725-5075 psi), std setting 280 bar (4060 psi) @ 5 l/min (1.32 US gpm)
TYPE: **VOSL/V1516/34F1/G5.p0.PR/ac** CODE: 1515742102
DESCRIPTION: Steel body, zero differential pilot ratio, range 50-350 bar (725-5075 psi), std setting 280 bar (4060 psi) @ 5 l/min (1.32 US gpm)

Vented (V) configuration with G3/4 thread and F2 flange

TYPE: **VOSL/V1516/34F2/G5.p4.PR/ac** CODE: 1515742103
DESCRIPTION: Steel body, pilot ratio 1:4, range 50-350 bar (725-5075 psi), std setting 280 bar (4060 psi) @ 5 l/min (1.32 US gpm)
TYPE: **VOSL/V1516/34F2/G5.p8.PR/ac** CODE: 1515742104
DESCRIPTION: Steel body, pilot ratio 1:8, range 50-350 bar (725-5075 psi), std setting 280 bar (4060 psi) @ 5 l/min (1.32 US gpm)
TYPE: **VOSL/V1516/34F2/G5.p0.PR/ac** CODE: 1515742105
DESCRIPTION: Steel body, zero differential pilot ratio, range 50-350 bar (725-5075 psi), std setting 280 bar (4060 psi) @ 5 l/min (1.32 US gpm)
For other configurations please contact our Sales Dpt.

VOSL/V1516 Complete valves

Vented (V) configuration with SAE12 thread

TYPE: **VOSL/V1516/S12/G5.p4.PR/ac** CODE: 1514742200
DESCRIPTION: Steel body, pilot ratio 1:4, range 50-350 bar (725-5075 psi), std setting 280 bar (4060 psi) @ 5 l/min (1.32 US gpm)
TYPE: **VOSL/V1516/S12/G5.p8.PR/ac** CODE: 1514742201
DESCRIPTION: Steel body, pilot ratio 1:8, range 50-350 bar (725-5075 psi), std setting 280 bar (4060 psi) @ 5 l/min (1.32 US gpm)
TYPE: **VOSL/V1516/S12/G5.p0.PR/ac** CODE: 1514742202
DESCRIPTION: Steel body, zero differential pilot ratio, range 50-350 bar (725-5075 psi), std setting 280 bar (4060 psi) @ 5 l/min (1.32 US gpm)

Vented (V) configuration with SAE12 thread and F1 flange

TYPE: **VOSL/V1516/S12F1/G5.p4.PR/ac** CODE: 1515742100
DESCRIPTION: Steel body, pilot ratio 1:4, range 50-350 bar (725-5075 psi), std setting 280 bar (4060 psi) @ 5 l/min (1.32 US gpm)
TYPE: **VOSL/V1516/S12F1/G5.p8.PR/ac** CODE: 1515742101
DESCRIPTION: Steel body, pilot ratio 1:8, range 50-350 bar (725-5075 psi), std setting 280 bar (4060 psi) @ 5 l/min (1.32 US gpm)
TYPE: **VOSL/V1516/S12F1/G5.p0.PR/ac** CODE: 1515742102
DESCRIPTION: Steel body, zero differential pilot ratio, range 50-350 bar (725-5075 psi), std setting 280 bar (4060 psi) @ 5 l/min (1.32 US gpm)

Vented (V) configuration with SAE12 thread and F2 flange

TYPE: **VOSL/V1516/S12F2/G5.p4.PR/ac** CODE: 1515742103
DESCRIPTION: Steel body, pilot ratio 1:4, range 50-350 bar (725-5075 psi), std setting 280 bar (4060 psi) @ 5 l/min (1.32 US gpm)
TYPE: **VOSL/V1516/S12F2/G5.p8.PR/ac** CODE: 1515742104
DESCRIPTION: Steel body, pilot ratio 1:8, range 50-350 bar (725-5075 psi), std setting 280 bar (4060 psi) @ 5 l/min (1.32 US gpm)
TYPE: **VOSL/V1516/S12F2/G5.p0.PR/ac** CODE: 1515742105
DESCRIPTION: Steel body, zero differential pilot ratio, range 50-350 bar (725-5075 psi), std setting 280 bar (4060 psi) @ 5 l/min (1.32 US gpm)
For other configurations please contact our Sales Dpt.

1 Pressure setting spring

TYPE	CODE	DESCRIPTION
For 1:4 and zero differential pilot ratio		
3	3MOL316450	For range 50-210 bar (725-3050 psi)
5	3MOL316430	For range 50-350 bar (725-5075 psi)
7	3MOL316411	For range 150-400 bar (2175-5800 psi)
For 1:8 pilot ratio		
5	3MOL316450	For range 50-350 bar (725-5075 psi)
7	3MOL316430	For range 150-400 bar (2175-5800 psi)

2 Antitampering cap

TYPE	CODE	DESCRIPTION
G	-	Screw setting
Z	4COP140311	Antitampering cap

Rating diagrams

VOSL/(N-V) 1516 (12-34) pressure drop vs. flow from D2->U2 and U2->D2

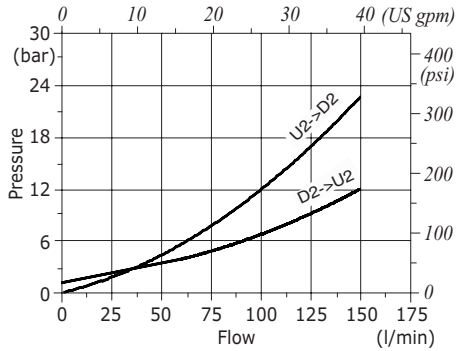

VOSL/(N-V) 1516 (12-34) pressure drop vs. flow from D1->U1 and U1->D1 pilot ratio 1:4

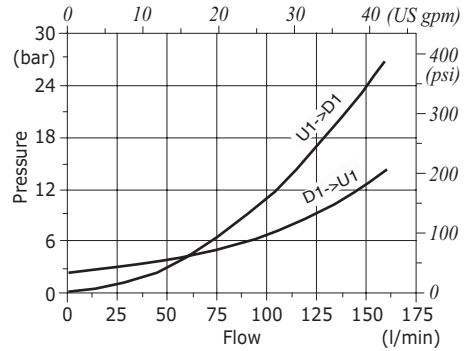

VOSL/(N-V) 1516 (12-34) pressure drop vs. flow from D1->U1 and U1->D1 pilot ratio 1:8

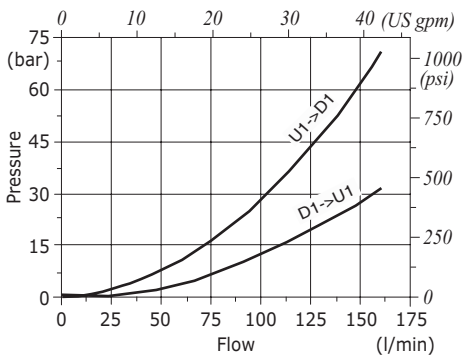

VOSL/(N-V) 1516 (12-34) pressure drop vs. flow from D1->U1 and U1->D1 zero differential pilot ratio

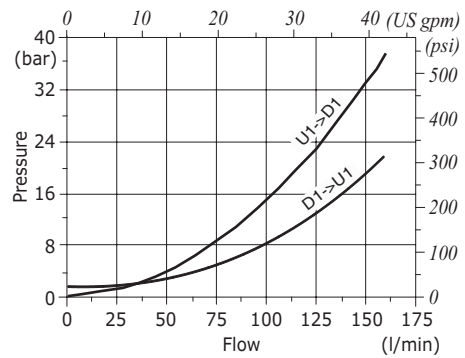



Type VODL/N1516/CS - VODL/V1516/CS counterbalance valves

- Double acting
- Load Sensitive (type N)
- Vented (type V)

Technical specifications and diagrams are measured with mineral oil of 46 cSt viscosity at 40°C (104°F) temperature.

VODL/N1516/CS (12-34) - VODL/V1516/CS (12-34)

Nominal flow	160 l/min (42.3 US gpm)
Max. pressure	350 bar ⁽¹⁾ (5100 psi) - 400 bar ⁽²⁾ (5800 psi)
Oil leakage	0.5 cm ³ /min (0.030 in ³ /min) - 10 drops/min at 80% of pressure setting
Fluid	mineral based oil
Viscosity	from 10 to 200 cSt
Max. level of contamination	18/16/13 ISO4406
Fluid temperature	with NBR seals from -20°C (-4°F) to 90°C (194°F)
Environmental temp. for working conditions	from -20°C (-4°F) to 50°C (122°F)
Weight	VODL/N1516/CS/12: 5.40 kg (11.90 lb) - VODL/N1516/CS/34: 5.30 kg (11.68 lb) VODL/V1516/CS/12: 5.40 kg (11.90 lb) - VODL/V1516/CS/34: 5.30 kg (11.68 lb)

NOTE - For different conditions, please contact Walvoil Sales Dpt. - ⁽¹⁾According to NFPA T 2.6.1., fatigue rating verified for 1 million cycles on 6 sample valves with test Pressure = 1.23 x Max. pressure indicated - ⁽²⁾Intermittent pressure at max. 100,000 cycles with specific internal testing.

VODL/N1516/CS

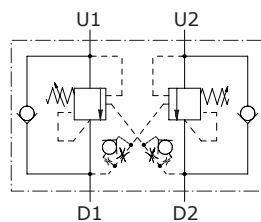

VODL/V1516/CS

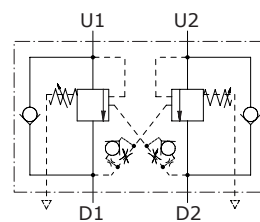

VODL/N1516/CS/F2

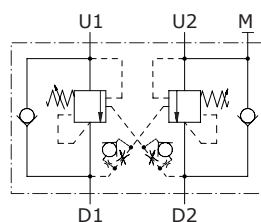

VODL/V1516/CS/F2

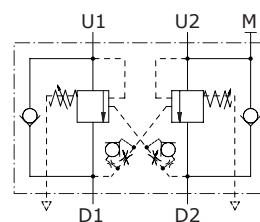

Dimensions

VODL/...1516/CS/12 - VODL/...1516/CS/34

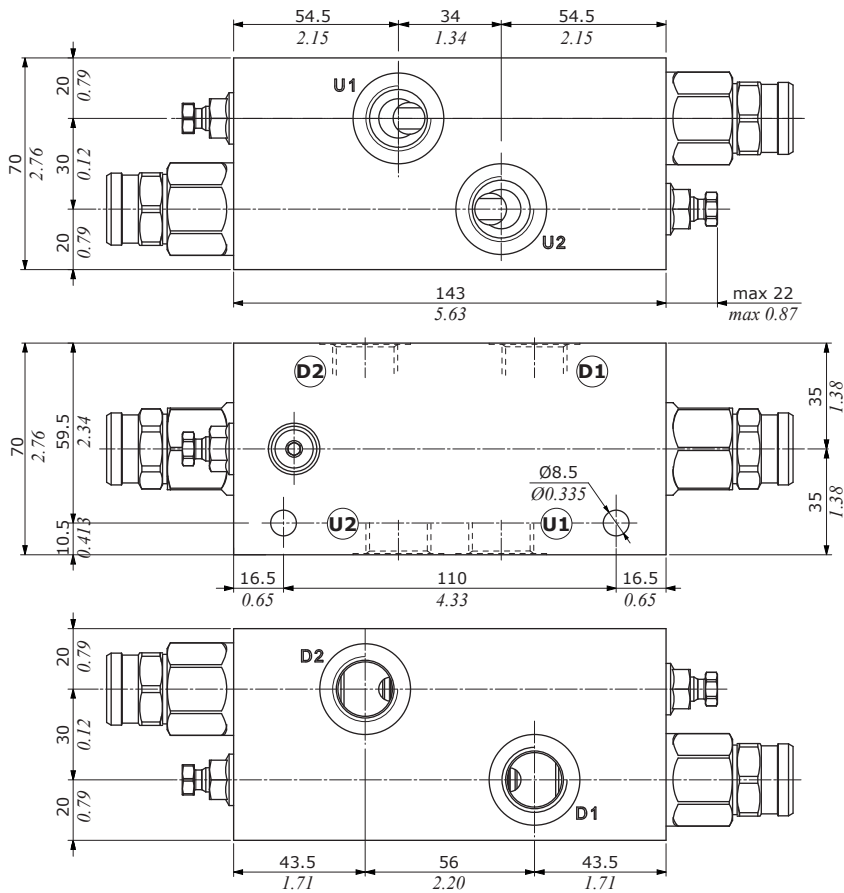

Valve type	D1	D2	U1	U2	M
VODL/...1516/CS/12	G1/2	G1/2	-	-	-
VODL/...1516/CS/34	G3/4	G3/4	-	-	-
VODL/...1516/CS/12F2	G1/2	Ø12 Ø0.472	G1/4	-	-
VODL/...1516/CS/34F2	G3/4	Ø12 Ø0.472	G1/4	-	-

Valve type	D1	D2	U1	U2	M
VODL/...1516/CS/S10	SAE10	SAE10	-	-	-
VODL/...1516/CS/S12	SAE12	SAE12	-	-	-
VODL/...1516/CS/S10F2	SAE10	Ø12 Ø0.472	G1/4	-	-
VODL/...1516/CS/S12F2	SAE12	Ø12 Ø0.472	G1/4	-	-

VODL/...1516/CS/12F2 - VODL/...1516/CS/34F2

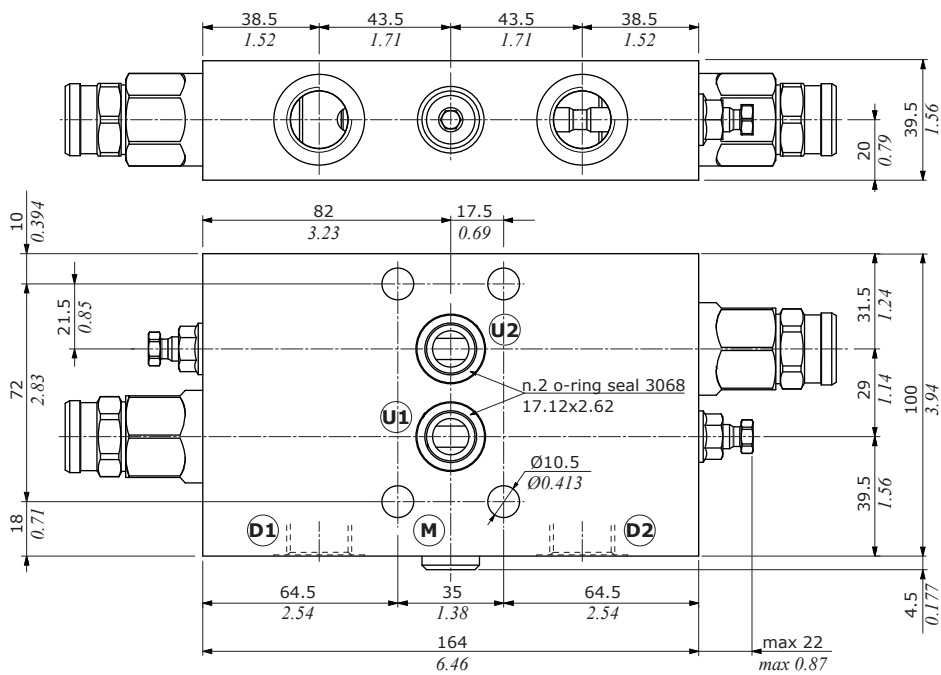

VODL/N configuration

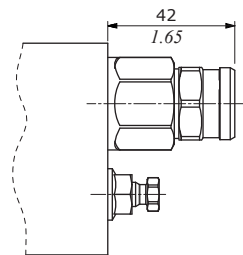

VODL/V configuration

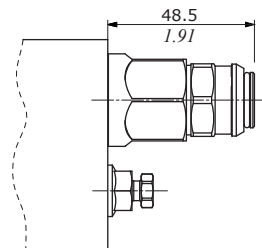

Ordering codes and description composition

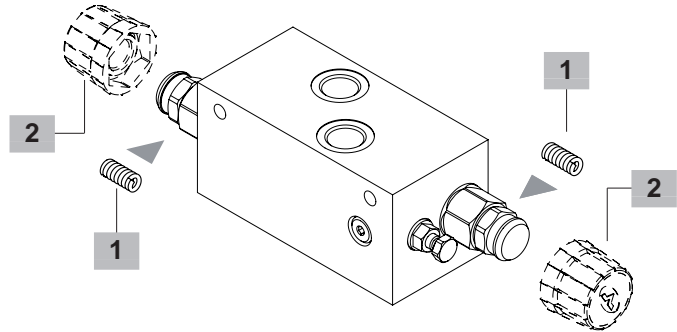
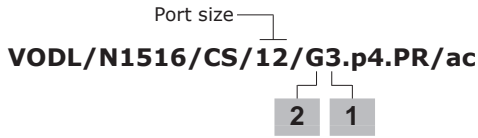

VODL/N1516 Complete valves

Load sensitive (N) configuration with G1/2 thread

Pilot ratio 1:4

TYPE: **VODL/N1516/CS/12/G3.p4.PR/ac** CODE: 1556532100
DESCRIPTION: Steel body, range 50-210 bar (725-3050 psi), std setting 150 bar (2175 psi) @ 5 l/min (1.32 US gpm)

TYPE: **VODL/N1516/CS/12/G5.p4.PR/ac** CODE: 1556532101
DESCRIPTION: Steel body, range 50-350 bar (725-5075 psi), std setting 280 bar (4060 psi) @ 5 l/min (1.32 US gpm)

TYPE: **VODL/N1516/CS/12/G7.p4.PR/ac** CODE: 1556532102
DESCRIPTION: range 150-400 bar (2175-5800 psi), std setting 350 bar (5075 psi) @ 5 l/min (1.32 US gpm)

Pilot ratio 1:8

TYPE: **VODL/N1516/CS/12/G5.p8.PR/ac** CODE: 1556532104
DESCRIPTION: Steel body, range 50-350 bar (72.5-5075 psi), std setting 280 bar (4060 psi) @ 5 l/min (1.32 US gpm)

TYPE: **VODL/N1516/CS/12/G7.p8.PR/ac** CODE: 1556532105
DESCRIPTION: Steel body, range 150-400 bar (2175-5800 psi), std setting 350 bar (5075 psi) @ 5 l/min (1.32 US gpm)

Zero differential pilot ratio

TYPE: **VODL/N1516/CS/12/G3.p0.PR/ac** CODE: 1556532106
DESCRIPTION: Steel body, range 50-210 bar (725-3050 psi), std setting 150 bar (2175 psi) @ 5 l/min (1.32 US gpm)

TYPE: **VODL/N1516/CS/12/G5.p0.PR/ac** CODE: 1556532107
DESCRIPTION: Steel body, range 50-350 bar (725-5075 psi), std setting 280 bar (4060 psi) @ 5 l/min (1.32 US gpm)

TYPE: **VODL/N1516/CS/12/G7.p0.PR/ac** CODE: 1556532108
DESCRIPTION: Steel body, range 150-400 bar (2175-5800 psi), std setting 350 bar (5075 psi) @ 5 l/min (1.32 US gpm)

Load sensitive (N) configuration with G1/2 thread and F2 flange

TYPE: **VODL/N1516/CS/12F2/G5.p4.PR/ac** CODE: 1557032100
DESCRIPTION: Steel body, pilot ratio 1:4, range 50-350 bar (725-5075 psi), std setting 280 bar (4060 psi) @ 5 l/min (1.32 US gpm)

TYPE: **VODL/N1516/CS/12F2/G5.p8.PR/ac** CODE: 1557032101
DESCRIPTION: Steel body, pilot ratio 1:8, range 50-350 bar (725-5075 psi), std setting 280 bar (4060 psi) @ 5 l/min (1.32 US gpm)

TYPE: **VODL/N1516/CS/12F2/G5.p0.PR/ac** CODE: 1557032102
DESCRIPTION: Steel body, zero differential pilot ratio, range 50-350 bar (725-5075 psi), std setting 280 bar (4060 psi) @ 5 l/min (1.32 US gpm)

Load sensitive (N) configuration with SAE10 thread

Pilot ratio 1:4

TYPE: **VODL/N1516/CS/S10/G3.p4.PR/ac** CODE: 1556532200
DESCRIPTION: Steel body, range 50-210 bar (725-3050 psi), std setting 150 bar (2175 psi) @ 5 l/min (1.32 US gpm)

TYPE: **VODL/N1516/CS/S10/G5.p4.PR/ac** CODE: 1556532201
DESCRIPTION: Steel body, range 50-350 bar (725-5075 psi), std setting 280 bar (4060 psi) @ 5 l/min (1.32 US gpm)

TYPE: **VODL/N1516/CS/S10/G7.p4.PR/ac** CODE: 1556532202
DESCRIPTION: range 150-400 bar (2175-5800 psi), std setting 350 bar (5075 psi) @ 5 l/min (1.32 US gpm)

VODL/N1516 Complete valves (continue)

Load sensitive (N) configuration with SAE10 thread

Pilot ratio 1:8

TYPE: **VODL/N1516/CS/S10/G5.p8.PR/ac** CODE: 1556532204
DESCRIPTION: Steel body, range 50-350 bar (72.5-5075 psi), std setting 280 bar (4060 psi) @ 5 l/min (1.32 US gpm)

TYPE: **VODL/N1516/CS/S10/G7.p8.PR/ac** CODE: 1556532205
DESCRIPTION: Steel body, range 150-400 bar (2175-5800 psi), std setting 350 bar (5075 psi) @ 5 l/min (1.32 US gpm)

Zero differential pilot ratio

TYPE: **VODL/N1516/CS/S10/G3.p0.PR/ac** CODE: 1556532206
DESCRIPTION: Steel body, range 50-210 bar (725-3050 psi), std setting 150 bar (2175 psi) @ 5 l/min (1.32 US gpm)

TYPE: **VODL/N1516/CS/S10/G5.p0.PR/ac** CODE: 1556532207
DESCRIPTION: Steel body, range 50-350 bar (725-5075 psi), std setting 280 bar (4060 psi) @ 5 l/min (1.32 US gpm)

TYPE: **VODL/N1516/CS/S10/G7.p0.PR/ac** CODE: 1556532208
DESCRIPTION: Steel body, range 150-400 bar (2175-5800 psi), std setting 350 bar (5075 psi) @ 5 l/min (1.32 US gpm)

Load sensitive (N) configuration with SAE10 thread and F2 flange

TYPE: **VODL/N1516/CS/S10F2/G5.p4.PR/ac** CODE: 1557032200
DESCRIPTION: Steel body, pilot ratio 1:4, range 50-350 bar (725-5075 psi), std setting 280 bar (4060 psi) @ 5 l/min (1.32 US gpm)

TYPE: **VODL/N1516/CS/S10F2/G5.p8.PR/ac** CODE: 1557032201
DESCRIPTION: Steel body, pilot ratio 1:8, range 50-350 bar (725-5075 psi), std setting 280 bar (4060 psi) @ 5 l/min (1.32 US gpm)

TYPE: **VODL/N1516/CS/S10F2/G5.p0.PR/ac** CODE: 1557032202
DESCRIPTION: Steel body, zero differential pilot ratio, range 50-350 bar (725-5075 psi), std setting 280 bar (4060 psi) @ 5 l/min (1.32 US gpm)

1 Pressure setting spring

TYPE	CODE	DESCRIPTION
For 1:4 and zero differential pilot ratio		
3	3MOL316450	For range 50-210 bar (725-3050 psi)
5	3MOL316430	For range 50-350 bar (725-5075 psi)
7	3MOL316411	For range 150-400 bar (2175-5800 psi)

For 1:8 pilot ratio

5	3MOL316450	For range 50-350 bar (725-5075 psi)
7	3MOL316430	For range 150-400 bar (2175-5800 psi)

2 Antitampering cap

TYPE	CODE	DESCRIPTION
G	-	Screw setting
Z	4COP140311	Antitampering cap

Ordering codes and description composition

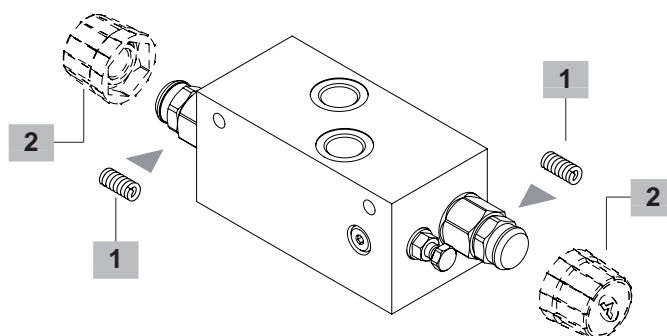
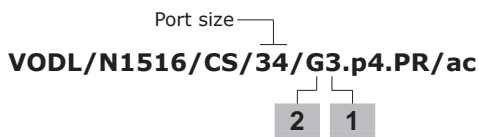

VODL/N1516 Complete valves

Load sensitive (N) configuration with G3/4 thread

TYPE: **VODL/N1516/CS/34/G5.p4.PR/ac** CODE: 1556542100
DESCRIPTION: Steel body, pilot ratio 1:4, range 50-350 bar (725-5075 psi), std setting 280 bar (4060 psi) @ 5 l/min (1.32 US gpm)

TYPE: **VODL/N1516/CS/34/G5.p8.PR/ac** CODE: 1556542101
DESCRIPTION: Steel body, pilot ratio 1:8, range 50-350 bar (725-5075 psi), std setting 280 bar (4060 psi) @ 5 l/min (1.32 US gpm)

TYPE: **VODL/N1516/CS/34/G5.p0.PR/ac** CODE: 1556542102
DESCRIPTION: Steel body, zero differential pilot ratio, range 50-350 bar (725-5075 psi), std setting 280 bar (4060 psi) 5 l/min (1.32 US gpm)

Load sensitive (N) configuration with G3/4 thread and F2 flange

TYPE: **VODL/N1516/CS/34F2/G5.p4.PR/ac** CODE: 1557042100
DESCRIPTION: Steel body, pilot ratio 1:4, range 50-350 bar (725-5075 psi), std setting 280 bar (4060 psi) @ 5 l/min (1.32 US gpm)

TYPE: **VODL/N1516/CS/34F2/G5.p8.PR/ac** CODE: 1557042101
DESCRIPTION: Steel body, pilot ratio 1:8, range 50-350 bar (725-5075 psi), std setting 280 bar (4060 psi) @ 5 l/min (1.32 US gpm)

TYPE: **VODL/N1516/CS/34F2/G5.p0.PR/ac** CODE: 1557042102
DESCRIPTION: Steel body, zero differential pilot ratio, range 50-350 bar (725-5075 psi), std setting 280 bar (4060 psi) @ 5 l/min (1.32 US gpm)

For other configurations please contact our Sales Dpt.

VODL/N1516 Complete valves

Load sensitive (N) configuration with SAE12 thread

TYPE: **VODL/N1516/CS/S12/G5.p4.PR/ac** CODE: 1556542200
DESCRIPTION: Steel body, pilot ratio 1:4, range 50-350 bar (725-5075 psi), std setting 280 bar (4060 psi) @ 5 l/min (1.32 US gpm)

TYPE: **VODL/N1516/CS/S12/G5.p8.PR/ac** CODE: 1556542201
DESCRIPTION: Steel body, pilot ratio 1:8, range 50-350 bar (725-5075 psi), std setting 280 bar (4060 psi) @ 5 l/min (1.32 US gpm)

TYPE: **VODL/N1516/CS/S12/G5.p0.PR/ac** CODE: 1556542202
DESCRIPTION: Steel body, zero differential pilot ratio, range 50-350 bar (725-5075 psi), std setting 280 bar (4060 psi) 5 l/min (1.32 US gpm)

Load sensitive (N) configuration with SAE12 thread and F2 flange

TYPE: **VODL/N1516/CS/S12F2/G5.p4.PR/ac** CODE: 1557042200
DESCRIPTION: Steel body, pilot ratio 1:4, range 50-350 bar (725-5075 psi), std setting 280 bar (4060 psi) @ 5 l/min (1.32 US gpm)

TYPE: **VODL/N1516/CS/S12F2/G5.p8.PR/ac** CODE: 1557042201
DESCRIPTION: Steel body, pilot ratio 1:8, range 50-350 bar (725-5075 psi), std setting 280 bar (4060 psi) @ 5 l/min (1.32 US gpm)

TYPE: **VODL/N1516/CS/S12F2/G5.p0.PR/ac** CODE: 1557042202
DESCRIPTION: Steel body, zero differential pilot ratio, range 50-350 bar (725-5075 psi), std setting 280 bar (4060 psi) @ 5 l/min (1.32 US gpm)

For other configurations please contact our Sales Dpt.

1 Pressure setting spring

TYPE	CODE	DESCRIPTION
For 1:4 and zero differential pilot ratio		
3	3MOL316450	For range 50-210 bar (725-3050 psi)
5	3MOL316430	For range 50-350 bar (725-5075 psi)
7	3MOL316411	For range 150-400 bar (2175-5800 psi)

For 1:8 pilot ratio

5	3MOL316450	For range 50-350 bar (725-5075 psi)
7	3MOL316430	For range 150-400 bar (2175-5800 psi)

2 Antitampering cap

TYPE	CODE	DESCRIPTION
G	-	Screw setting
Z	4COP140311	Antitampering cap

Ordering codes and description composition

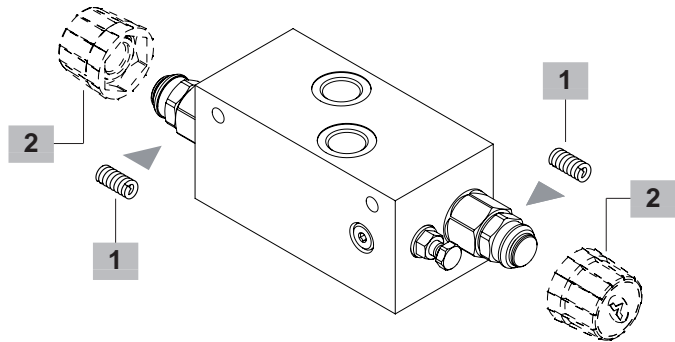
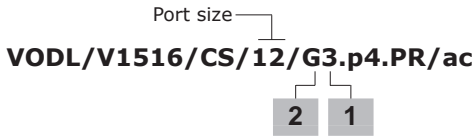

VODL/V1516 Complete valves

Vented (V) configuration with G1/2 thread

Pilot ratio 1:4

TYPE: **VODL/V1516/CS/12/G3.p4.PR/ac** CODE: 1556632100
DESCRIPTION: Steel body, range 50-210 bar (725-3050 psi), std setting 150 bar (2175 psi) @ 5 l/min (1.32 US gpm)

TYPE: **VODL/V1516/CS/12/G5.p4.PR/ac** CODE: 1556632101
DESCRIPTION: Steel body, range 50-350 bar (725-5075 psi), std setting 280 bar (4060 psi) @ 5 l/min (1.32 US gpm)

TYPE: **VODL/V1516/CS/12/G7.p4.PR/ac** CODE: 1556632102
DESCRIPTION: Steel body, range 150-400 bar (2175-5800 psi), std setting 350 bar (5075 psi) @ 5 l/min (1.32 US gpm)

Pilot ratio 1:8

TYPE: **VODL/V1516/CS/12/G5.p8.PR/ac** CODE: 1556632104
DESCRIPTION: Steel body, range 50-350 bar (725-5075 psi), std setting 280 bar (4060 psi) @ 5 l/min (1.32 US gpm)

TYPE: **VODL/N1516/CS/12/G7.p8.PR/ac** CODE: 1556532105
DESCRIPTION: Steel body, range 150-400 bar (2175-5800 psi), std setting 350 bar (5075 psi) @ 5 l/min (1.32 US gpm)

Zero differential pilot ratio

TYPE: **VODL/V1516/CS/12/G3.p0.PR/ac** CODE: 1556632106
DESCRIPTION: Steel body, range 50-210 bar (725-3050 psi), std setting 150 bar (2175 psi) @ 5 l/min (1.32 US gpm)

TYPE: **VODL/V1516/CS/12/G5.p0.PR/ac** CODE: 1556632107
DESCRIPTION: Steel body, range 50-350 bar (725-5075 psi), std setting 280 bar (4060 psi) @ 5 l/min (1.32 US gpm)

TYPE: **VODL/V1516/CS/12/G7.p0.PR/ac** CODE: 1556632108
DESCRIPTION: Steel body, range 150-400 bar (2175-5800 psi), std setting 350 bar (5075 psi) @ 5 l/min (1.32 US gpm)

Vented (V) configuration with G1/2 thread and F2 flange

TYPE: **VODL/V1516/CS/12F2/G5.p4.PR/ac** CODE: 1557132100
DESCRIPTION: Steel body, pilot ratio 1:4, range 50-350 bar (725-5075 psi), std setting 280 bar (4060 psi) @ 5 l/min (1.32 US gpm)

TYPE: **VODL/V1516/CS/12F2/G5.p8.PR/ac** CODE: 1557132101
DESCRIPTION: Steel body, pilot ratio 1:8, range 50-350 bar (725-5075 psi), std setting 280 bar (4060 psi) @ 5 l/min (1.32 US gpm)

TYPE: **VODL/V1516/CS/12F2/G5.p0.PR/ac** CODE: 1557132102
DESCRIPTION: Steel body, zero differential pilot ratio, range 50-350 bar (725-5075 psi), std setting 280 bar (4060 psi) @ 5 l/min (1.32 US gpm)

Vented (V) configuration with SAE10 thread

Pilot ratio 1:4

TYPE: **VODL/V1516/CS/S10/G3.p4.PR/ac** CODE: 1556632200
DESCRIPTION: Steel body, range 50-210 bar (725-3050 psi), std setting 150 bar (2175 psi) @ 5 l/min (1.32 US gpm)

TYPE: **VODL/V1516/CS/S10/G5.p4.PR/ac** CODE: 1556632201
DESCRIPTION: Steel body, range 50-350 bar (725-5075 psi), std setting 280 bar (4060 psi) @ 5 l/min (1.32 US gpm)

TYPE: **VODL/V1516/CS/S10/G7.p4.PR/ac** CODE: 1556632202
DESCRIPTION: Steel body, range 150-400 bar (2175-5800 psi), std setting 350 bar (5075 psi) @ 5 l/min (1.32 US gpm)

VODL/V1516 Complete valves

Vented (V) configuration with SAE10 thread

Pilot ratio 1:8

TYPE: **VODL/V1516/CS/S10/G5.p8.PR/ac** CODE: 1556632204
DESCRIPTION: Steel body, range 50-350 bar (725-5075 psi), std setting 280 bar (4060 psi) @ 5 l/min (1.32 US gpm)

TYPE: **VODL/V1516/CS/S10/G7.p8.PR/ac** CODE: 1556632205
DESCRIPTION: Steel body, range 150-400 bar (2175-5800 psi), std setting 350 bar (5075 psi) @ 5 l/min (1.32 US gpm)

Zero differential pilot ratio

TYPE: **VODL/V1516/CS/S10/G3.p0.PR/ac** CODE: 1556632206
DESCRIPTION: Steel body, range 50-210 bar (725-3050 psi), std setting 150 bar (2175 psi) @ 5 l/min (1.32 US gpm)

TYPE: **VODL/V1516/CS/S10/G5.p0.PR/ac** CODE: 1556632207
DESCRIPTION: Steel body, range 50-350 bar (725-5075 psi), std setting 280 bar (4060 psi) @ 5 l/min (1.32 US gpm)

TYPE: **VODL/V1516/CS/S10/G7.p0.PR/ac** CODE: 1556632208
DESCRIPTION: Steel body, range 150-400 bar (2175-5800 psi), std setting 350 bar (5075 psi) @ 5 l/min (1.32 US gpm)

Vented (V) configuration with SAE10 thread and F2 flange

TYPE: **VODL/V1516/CS/S10F2/G5.p4.PR/ac** CODE: 1557132200
DESCRIPTION: Steel body, pilot ratio 1:4, range 50-350 bar (725-5075 psi), std setting 280 bar (4060 psi) @ 5 l/min (1.32 US gpm)

TYPE: **VODL/V1516/CS/S10F2/G5.p8.PR/ac** CODE: 1557132201
DESCRIPTION: Steel body, pilot ratio 1:8, range 50-350 bar (725-5075 psi), std setting 280 bar (4060 psi) @ 5 l/min (1.32 US gpm)

TYPE: **VODL/V1516/CS/S10F2/G5.p0.PR/ac** CODE: 1557132202
DESCRIPTION: Steel body, zero differential pilot ratio, range 50-350 bar (725-5075 psi), std setting 280 bar (4060 psi) @ 5 l/min (1.32 US gpm)

For other configurations please contact our Sales Dpt.

1 Pressure setting spring

TYPE	CODE	DESCRIPTION
For 1:4 and zero differential pilot ratio		
3	3MOL316450	For range 50-210 bar (725-3050 psi)
5	3MOL316430	For range 50-350 bar (725-5075 psi)
7	3MOL316411	For range 150-400 bar (2175-5800 psi)

For 1:8 pilot ratio

5	3MOL316450	For range 50-350 bar (725-5075 psi)
7	3MOL316430	For range 150-400 bar (2175-5800 psi)

2 Antitampering cap

TYPE	CODE	DESCRIPTION
G	-	Screw setting
Z	4COP140311	Antitampering cap

Ordering codes and description composition

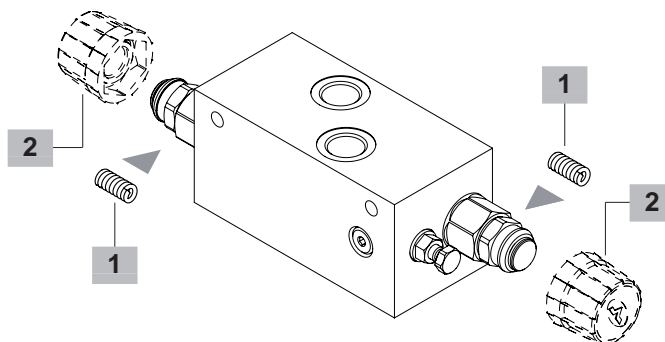
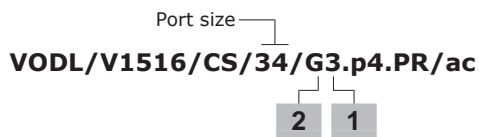

VODL/V1516 Complete valves

Vented (V) configuration with G3/4 thread

TYPE: **VODL/V1516/CS/34/G5.p4.PR/ac** CODE: 1556642100
DESCRIPTION: Steel body, pilot ratio 1:4, range 50-350 bar (725-5075 psi), std setting 280 bar (4060 psi) @ 5 l/min (1.32 US gpm)

TYPE: **VODL/V1516/CS/34/G5.p8.PR/ac** CODE: 1556642101
DESCRIPTION: Steel body, pilot ratio 1:8, range 50-350 bar (725-5075 psi), std setting 280 bar (4060 psi) @ 5 l/min (1.32 US gpm)

TYPE: **VODL/V1516/CS/34/G5.p0.PR/ac** CODE: 1556642102
DESCRIPTION: Steel body, zero differential pilot ratio, range 50-350 bar (725-5075 psi), std setting 280 bar (4060 psi) @ 5 l/min (1.32 US gpm)

Vented (V) configuration with G3/4 thread and F2 flange
TYPE: **VODL/V1516/CS/34F2/G5.p4.PR/ac** CODE: 1557142100
DESCRIPTION: Steel body, pilot ratio 1:4, range 50-350 bar (725-5075 psi), std setting 280 bar (4060 psi) @ 5 l/min (1.32 US gpm)

TYPE: **VODL/V1516/CS/34F2/G5.p8.PR/ac** CODE: 1557142101
DESCRIPTION: Steel body, pilot ratio 1:8, range 50-350 bar (725-5075 psi), std setting 280 bar (4060 psi) @ 5 l/min (1.32 US gpm)

TYPE: **VODL/V1516/CS/34F2/G5.p0.PR/ac** CODE: 1557142102
DESCRIPTION: Steel body, zero differential pilot ratio, range 50-350 bar (725-5075 psi), std setting 280 bar (4060 psi) @ 5 l/min (1.32 US gpm)

For other configurations please contact our Sales Dpt.

VODL/V1516 Complete valves

Vented (V) configuration with SAE12 thread

TYPE: **VODL/V1516/CS/S12/G5.p4.PR/ac** CODE: 1556642200
DESCRIPTION: Steel body, pilot ratio 1:4, range 50-350 bar (725-5075 psi), std setting 280 bar (4060 psi) @ 5 l/min (1.32 US gpm)

TYPE: **VODL/V1516/CS/S12/G5.p8.PR/ac** CODE: 1556642201
DESCRIPTION: Steel body, pilot ratio 1:8, range 50-350 bar (725-5075 psi), std setting 280 bar (4060 psi) @ 5 l/min (1.32 US gpm)

TYPE: **VODL/V1516/CS/S12/G5.p0.PR/ac** CODE: 1556642202
DESCRIPTION: Steel body, zero differential pilot ratio, range 50-350 bar (725-5075 psi), std setting 280 bar (4060 psi) @ 5 l/min (1.32 US gpm)

Vented (V) configuration with SAE12 thread and F2 flange
TYPE: **VODL/V1516/CS/S12F2/G5.p4.PR/ac** CODE: 1557142200
DESCRIPTION: Steel body, pilot ratio 1:4, range 50-350 bar (725-5075 psi), std setting 280 bar (4060 psi) @ 5 l/min (1.32 US gpm)

TYPE: **VODL/V1516/CS/S12F2/G5.p8.PR/ac** CODE: 1557142201
DESCRIPTION: Steel body, pilot ratio 1:8, range 50-350 bar (725-5075 psi), std setting 280 bar (4060 psi) @ 5 l/min (1.32 US gpm)

TYPE: **VODL/V1516/CS/S12F2/G5.p0.PR/ac** CODE: 1557142202
DESCRIPTION: Steel body, zero differential pilot ratio, range 50-350 bar (725-5075 psi), std setting 280 bar (4060 psi) @ 5 l/min (1.32 US gpm)

For other configurations please contact our Sales Dpt.

1 Pressure setting spring

TYPE	CODE	DESCRIPTION
For 1:4 and zero differential pilot ratio		
3	3MOL316450	For range 50-210 bar (725-3050 psi)
5	3MOL316430	For range 50-350 bar (725-5075 psi)
7	3MOL316411	For range 150-400 bar (2175-5800 psi)
For 1:8 pilot ratio		
5	3MOL316450	For range 50-350 bar (725-5075 psi)
7	3MOL316430	For range 150-400 bar (2175-5800 psi)

2 Antitampering cap

TYPE	CODE	DESCRIPTION
G	-	Screw setting
Z	4COP140311	Antitampering cap

Rating diagrams

VODL/(N-V) 1516/CS (12-34) pressure drop vs. flow from D2->U2 and U2->D2

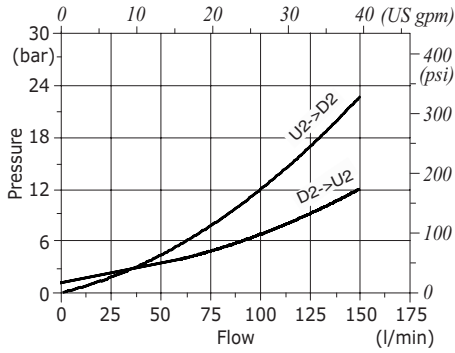

VODL/(N-V) 1516/CS (12-34) pressure drop vs. flow from D1->U1 and U1->D1 pilot ratio 1:4

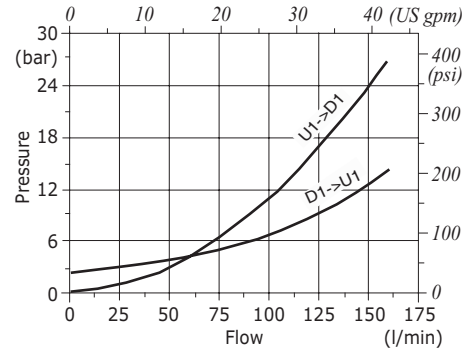

VODL/(N-V) 1516/CS (12-34) pressure drop vs. flow from D1->U1 and U1->D1 pilot ratio 1:8

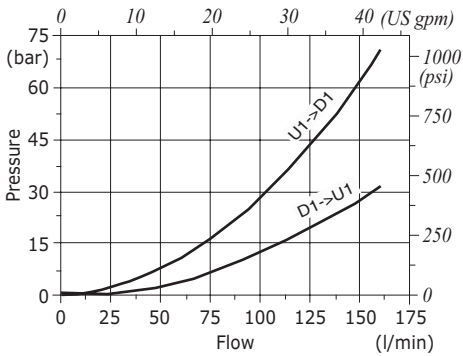

VODL/(N-V) 1516/CS (12-34) pressure drop vs. flow from D1->U1 and U1->D1 zero differential pilot ratio

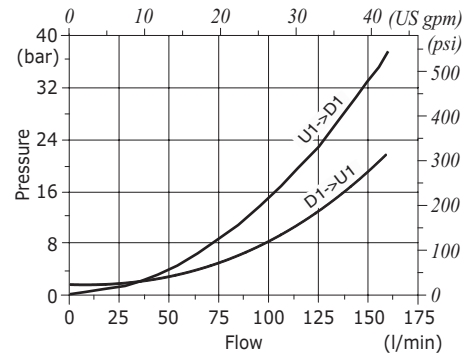



Type VOSL counterbalance valves

- Single acting
- Load sensitive

Technical specifications and diagrams are measured with mineral oil of 46 cSt viscosity at 40°C (104°F) temperature.

	VOSL 38	VOSL 12	VOSL 34	VOSL 100	
Nominal flow	35 l/min (9.2 US gpm)	70 l/min (18.4 US gpm)	100 l/min (26.4 US gpm)	180 l/min (47.6 US gpm)	
Max. pressure	Aluminium body = 210 bar (3050 psi) Steel body = 350 bar (5100 psi)				
Oil leakage	0.25 cm ³ /min - 0.015 in ³ /min. (5 drops) at 210 bar - 3050 psi at 80% of pressure setting				
Fluid	mineral based oil				
Viscosity	from 10 to 200 cSt				
Max. level of contamination	18/16/13 ISO4406				
Fluid temperature	with NBR seals from -20°C (-4°F) to 80°C (176°F)				
Environmental temp. for working conditions	from -40°C (-40°F) to 100°C (212°F)				
Weight	<i>aluminium</i>	0.78 kg (1.71 lb)	1.00 kg (2.20 lb)	1.85 kg (4.07 lb)	3.26 kg (7.18 lb)
	<i>steel</i>	1.52 kg (3.35 lb)	1.95 kg (4.29 lb)	3.55 kg (7.82 lb)	7.07 kg (15.5 lb)

NOTE - For different conditions, please contact Walvoil Sales Dpt.

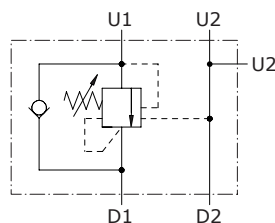

Dimensions

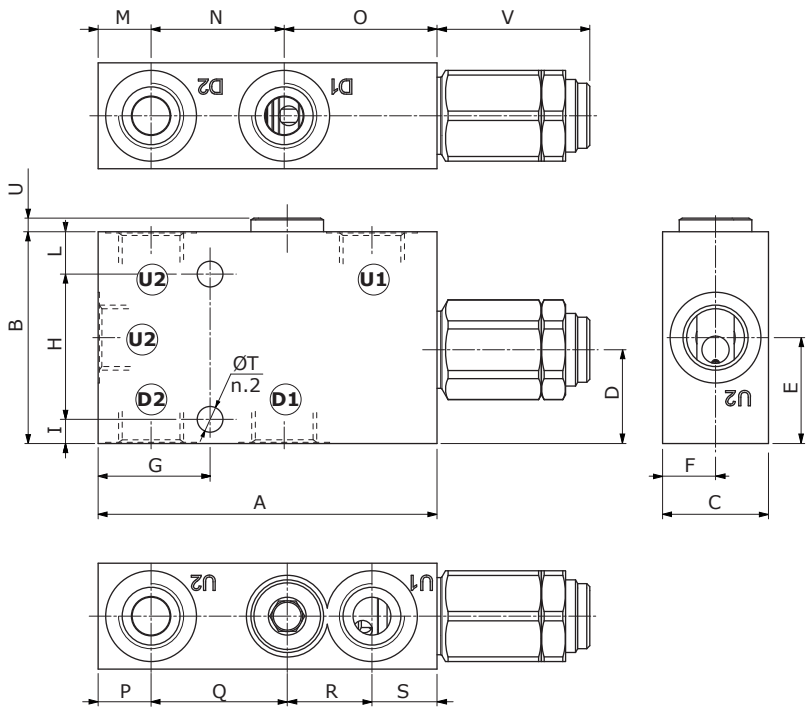

Valve type	D1	D2	U1	U2
VOSL 38	G3/8	G3/8	G3/8	G3/8
VOSL 12	G1/2	G1/2	G1/2	G1/2
VOSL 34	G3/4	G3/4	G3/4	G3/4
VOSL 100	G1"	G1"	G1"	G1"

Dimensions are in mm-in

Valve type	A	B	C	D	E	F	G	H	I	L	M	N	O	P	Q	R	S	ØT	U	V
VOSL 38	105 4.13	65 2.56	30 1.18	27 1.06	32.5 1.30	15 0.59	34 1.34	40 1.57	8 0.315	17 0.67	16 0.63	38 1.50	51 2.01	16 0.63	38 1.50	29 1.14	22 0.87	8.5 0.335	4.5 0.177	52 2.05
VOSL 12	112 4.41	70 2.76	35 1.38	31 1.22	35 1.38	17.5 0.69	37 1.46	48 1.89	8 0.315	14 0.55	17.5 0.69	44 1.73	50.5 1.99	17.5 0.69	45 1.77	28 1.10	21.5 0.85	8.5 0.335	4.5 0.177	57 2.24
VOSL 34	140 5.51	90 3.54	40 1.57	36 1.42	45 1.77	20 0.79	52 2.05	70 2.76	10 0.394	10 0.394	22 0.87	53 2.09	65 2.56	22 0.87	53 2.09	35 1.38	30 1.18	10.5 0.413	5.5 0.217	66 2.60
VOSL 100	174 6.85	100 3.64	60 2.36	37 1.46	50 1.97	37 1.46	64 2.52	80 3.15	10 0.394	10 0.394	32 1.26	66 2.60	76 2.99	32 1.26	66 2.60	46 1.81	30 1.18	10.5 0.413	12.5 0.492	66 2.60

Ordering codes

VOSL complete valves

- TYPE: **VOSL 38/TR.S.p4** CODE: 1510021102
DESCRIPTION: Aluminium body, G3/8 ports, pilot ratio 1:4, range 50-350 bar (725-5075 psi), std setting 280 bar (4060 psi) @ 5 l/min (1.32 US gpm)
 - TYPE: **VOSL 12/TR.S.p7** CODE: 1510031102
DESCRIPTION: Aluminium body, G1/2 ports, pilot ratio 1:7, range 50-350 bar (725-5075 psi), std setting 280 bar (4060 psi) @ 5 l/min (1.32 US gpm)
 - TYPE: **VOSL 34/TR.S.p7** CODE: 1510041102
DESCRIPTION: Aluminium body, G3/4 ports, pilot ratio 1:7, range 50-350 bar (725-5075 psi), std setting 280 bar (4060 psi) @ 5 l/min (1.32 US gpm)
 - TYPE: **VOSL 100/TR.S.p7** CODE: 1510051102
DESCRIPTION: Aluminium body, G1" ports, pilot ratio 1:7, range 50-350 bar (725-5075 psi), std setting 280 bar (4060 psi) @ 5 l/min (1.32 US gpm)
- For other configurations and steel body, please contact our Sales Dpt

VOSL 38 pressure drop vs. flow from D1->U1 and U1->D1

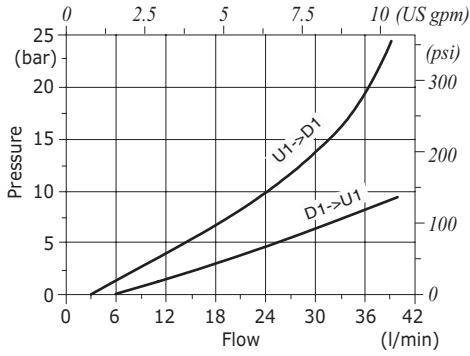

VOSL 12 pressure drop vs. flow from D1->U1 and U1->D1

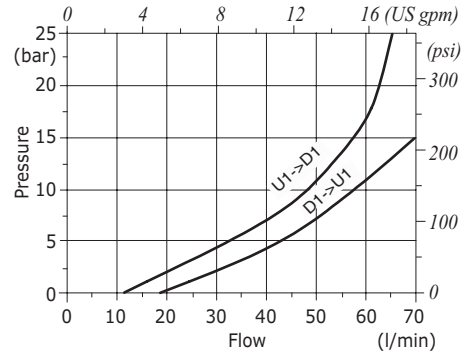

VOSL 34 pressure drop vs. flow from D1->U1 and U1->D1

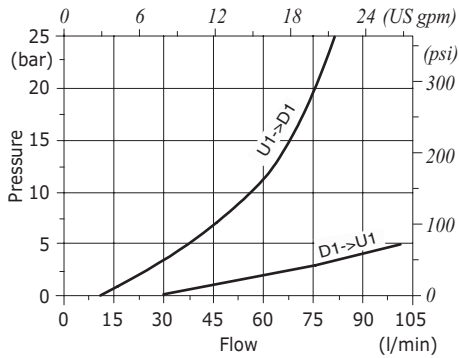

VOSL 100 pressure drop vs. flow from D1->U1 and U1->D1

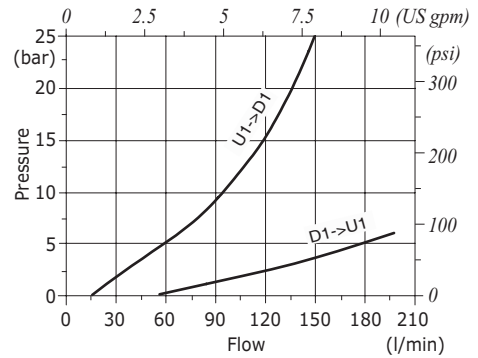

Type VOSL/CC counterbalance valves

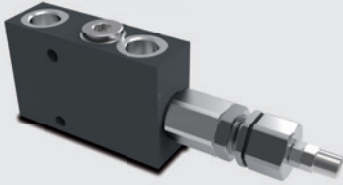

- Single acting
- Relief compensated

Technical specifications and diagrams are measured with mineral oil of 46 cSt viscosity at 40°C (104°F) temperature.

	VOSL/CC 38	VOSL/CC 12	VOSL/CC 34	VOSL/CC 100	
Nominal flow	35 l/min (9.2 US gpm)	70 l/min (18.4 US gpm)	100 l/min (26.4 US gpm)	180 l/min (47.6 US gpm)	
Max. pressure	Aluminium body = 210 bar (3050 psi) Steel body = 350 bar (5100 psi)				
Oil leakage	0.25 cm ³ /min - 0.015 in ³ /min. (5 drops) at 210 bar - 3050 psi at 80% of pressure setting				
Fluid	mineral based oil				
Viscosity	from 10 to 200 cSt				
Max. level of contamination	18/16/13 ISO4406				
Fluid temperature	with NBR seals from -20°C (-4°F) to 80°C (176°F)				
Environmental temp. for working conditions	from -40°C (-40°F) to 100°C (212°F)				
Weight	aluminium	1.01 kg (2.23 lb)	1.16 kg (2.56 lb)	1.94 kg (4.28 lb)	3.33 kg (7.34 lb)
	steel	1.81 kg (3.99 lb)	2.11 kg (4.65 lb)	3.61 kg (7.96 lb)	7.07 kg (15.5 lb)

NOTE - For different conditions, please contact Walvoil Sales Dpt.

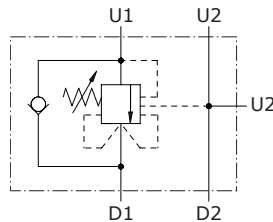

Dimensions

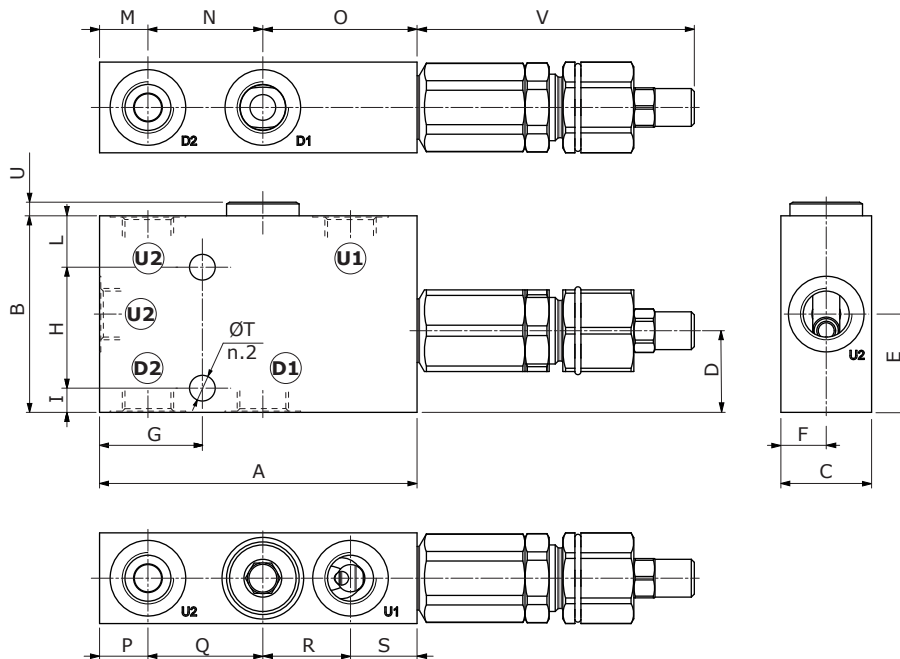

Valve type	D1	D2	U1	U2
VOSL/CC 38	G3/8	G3/8		
VOSL/CC 12	G1/2	G1/2		
VOSL/CC 34	G3/4	G3/4		
VOSL/CC 100	G1"	G1"		

Dimensions are in mm-in

Valve type	A	B	C	D	E	F	G	H	I	L	M	N	O	P	Q	R	S	ØT	U	V
VOSL/CC 38	105	65	30	27	32.5	15	34	40	8	17	16	38	51	16	38	29	22	8.5	4.5	92.2
	4.13	2.56	1.18	1.06	1.30	0.59	1.34	1.57	0.315	0.67	0.63	1.50	2.01	0.63	1.50	1.14	0.87	0.335	0.177	3.63
VOSL/CC 12	112	70	35	31	35	17.5	37	48	8	14	17.5	44	50.5	17.5	45	28	21.5	8.5	4.5	99.7
	4.41	2.76	1.38	1.22	1.38	0.69	1.46	1.89	0.315	0.55	0.69	1.73	1.99	0.69	1.77	1.10	0.85	0.335	0.177	3.93
VOSL/CC 34	140	90	40	36	45	20	52	70	10	10	22	53	65	22	53	35	30	10.5	5.5	101.7
	5.51	3.54	1.57	1.42	1.77	0.79	2.05	2.76	0.394	0.394	0.87	2.09	2.56	0.87	2.09	1.38	1.18	0.413	0.217	4.00
VOSL/CC 100	174	100	60	37	50	37	64	80	10	10	32	66	76	32	66	46	30	10.5	12.5	101.7
	6.85	3.64	2.36	1.46	1.97	1.46	2.52	3.15	0.394	0.394	1.26	2.60	2.99	1.26	2.60	1.81	1.18	0.413	0.492	4.00

Ordering codes

VOSL/CC complete valves

TYPE: **VOSL/CC 38/TR.S.p4** CODE: 1514921100
 DESCRIPTION: Aluminium body, G3/8 ports, pilot ratio 1:4, range 50-350 bar (725-5075 psi), std setting 280 bar (4060 psi) @ 5 l/min (1.32 US gpm)

TYPE: **VOSL/CC 12/TR.S.p7** CODE: 1514931100
 DESCRIPTION: Aluminium body, G1/2 ports, pilot ratio 1:7, range 50-350 bar (725-5075 psi), std setting 280 bar (4060 psi) 5 l/min (1.32 US gpm)

TYPE: **VOSL/CC 34/TR.S.p7** CODE: 1514941101
 DESCRIPTION: Aluminium body, G3/4 ports, pilot ratio 1:7, range 50-350 bar (725-5075 psi), std setting 280 bar (4060 psi) 5 l/min (1.32 US gpm)

TYPE: **VOSL/CC 100/TR.S.p7** CODE: 1514951100
 DESCRIPTION: Aluminium body, G1" ports, pilot ratio 1:7, range 50-350 bar (725-5075 psi), std setting 280 bar (4060 psi) 5 l/min (1.32 US gpm)

For other configurations and steel body, please contact our Sales Dpt

Rating diagrams

VOSL/CC 38 pressure drop vs. flow from D1->U1 and U1->D1

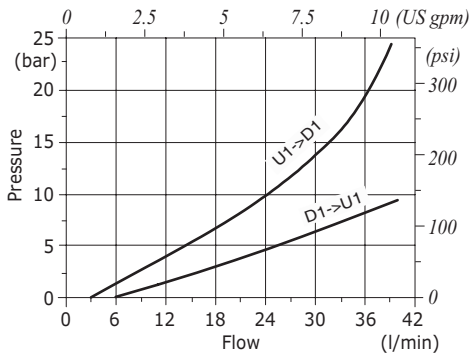

VOSL/CC 12 pressure drop vs. flow from D1->U1 and U1->D1

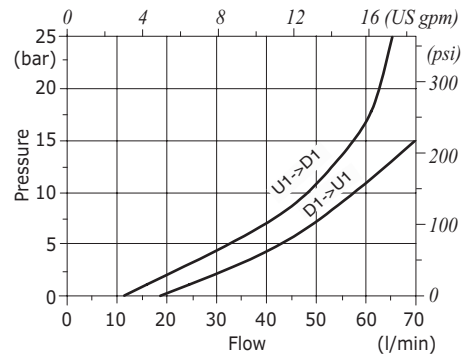

VOSL/CC 34 pressure drop vs. flow from D1->U1 and U1->D1

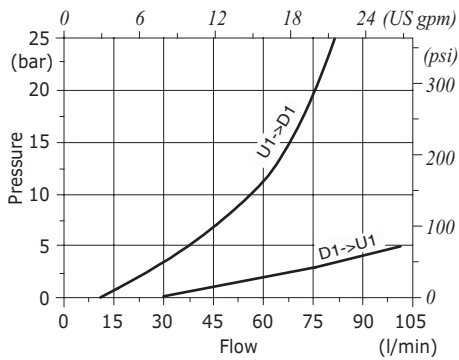

VOSL/CC 100 pressure drop vs. flow from D1->U1 and U1->D1

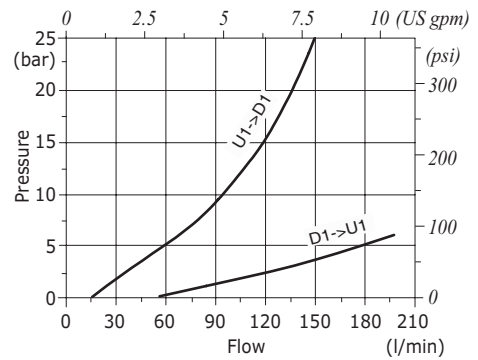



Type VOSL/SC counterbalance valves

- Single acting

Technical specifications and diagrams are measured with mineral oil of 46 cSt viscosity at 40°C (104°F) temperature.

	VOSL/SC 38	VOSL/SC 12	VOSL/SC 34	VOSL/SC 100	
Nominal flow	40 l/min (10.6 US gpm)	75 l/min (19.8 US gpm)	120 l/min (31.7 US gpm)	180 l/min (47.6 US gpm)	
Max. pressure	Aluminium body = 210 bar (3050 psi) Steel body = 350 bar (5100 psi)				
Oil leakage	0.25 cm ³ /min - 0.015 in ³ /min. (5 drops) at 210 bar - 3050 psi at 80% of pressure setting				
Fluid	mineral based oil				
Viscosity	from 10 to 200 cSt				
Max. level of contamination	18/16/13 ISO4406				
Fluid temperature	with NBR seals from -20°C (-4°F) to 80°C (176°F)				
Environmental temp. for working conditions	from -40°C (-40°F) to 100°C (212°F)				
Weight	<i>aluminium</i>	0.80 kg (1.76 lb)	1.06 kg (2.34 lb)	1.48 kg (3.26 lb)	3.13 kg (6.90 lb)
	<i>steel</i>	1.54 kg (3.40 lb)	2.15 kg (4.74 lb)	3.34 kg (7.36 lb)	7.64 kg (16.8 lb)

NOTE - For different conditions, please contact Walvoil Sales Dpt.

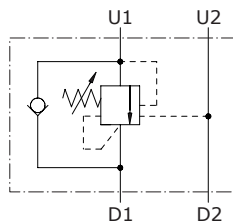

Dimensions

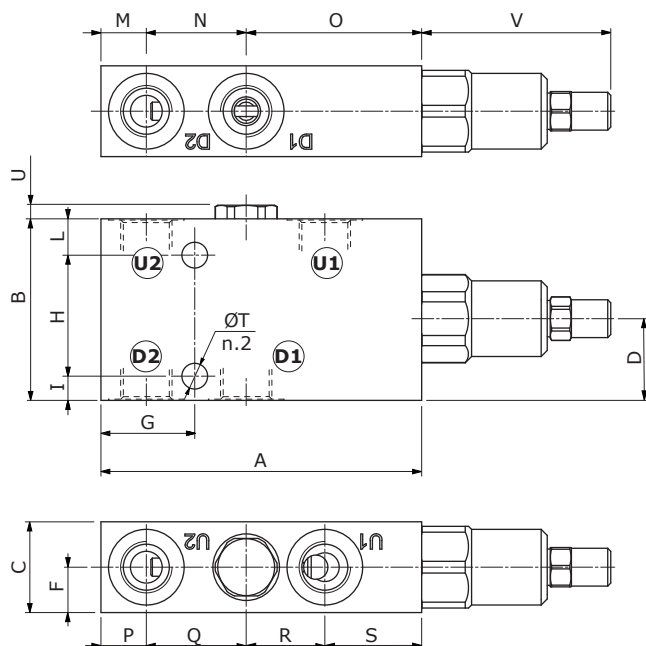

Valve type	D1	D2	U1	U2
VOSL/SC 38	G3/8	G3/8		
VOSL/SC 12	G1/2	G1/2		
VOSL/SC 34	G3/4	G3/4		
VOSL/SC 100	G1"	G1"		

Dimensions are in mm-in

Valve type	A	B	C	D	F	G	H	I	L	M	N	O	P	Q	R	S	ØT	U	V
VOSL/SC 38	106	60	30	27	15	31	40	8	12	15	33	58	15	33	26	32	8.5	4.5	62.5
	4.17	2.36	1.18	1.06	0.89	1.22	1.57	0.315	0.472	0.59	1.30	2.28	0.59	1.30	1.02	1.26	0.335	0.177	2.46
VOSL/SC 12	116	70	35	31	17.5	36	48	8	14	16	40	60	16	40	28	32	8.5	4.5	62.5
	4.57	2.76	1.38	1.22	0.69	1.42	1.89	0.315	0.55	0.63	1.57	2.36	0.63	1.57	1.10	1.26	0.335	0.177	2.46
VOSL/SC 34	136	90	40	36	20	44	70	10	10	20	48	68	20	48	34	34	10.5	5.5	62.5
	5.35	3.54	1.57	1.42	0.79	1.73	2.76	0.394	0.394	0.79	1.89	2.68	0.79	1.89	1.34	1.34	0.413	0.217	2.46
VOSL/SC 100	185	100	60	38	30	62	80	10	10	32	70	83	32	70	48	35	10.5	12.5	62.5
	7.28	3.94	2.36	1.50	1.18	2.44	3.15	0.394	0.394	1.26	2.76	3.27	1.26	2.76	1.89	1.38	0.413	0.492	2.46

Ordering codes

VOSL/SC complete valves

TYPE: **VOSL/SC 38/TR.S.p4.PG** CODE: 1520021108

DESCRIPTION: Aluminium body, G3/8 ports, pilot ratio 1:4, range 50-350 bar (725-5075 psi), std setting 280 bar (4060 psi) @ 5 l/min (1.32 US gpm)

TYPE: **VOSL/SC 12/TR.S.p7.PG** CODE: 1520031107

DESCRIPTION: Aluminium body, G1/2 ports, pilot ratio 1:7, range 50-350 bar (725-5075 psi), std setting 280 bar (4060 psi) @ 5 l/min (1.32 US gpm)

TYPE: **VOSL/SC 34/TR.S.p7.PG** CODE: 1520041102

DESCRIPTION: Aluminium body, G3/4 ports, pilot ratio 1:7, range 50-350 bar (725-5075 psi), std setting 280 bar (4060 psi) @ 5 l/min (1.32 US gpm)

TYPE: **VOSL/SC 100/TR.S.p7.PG** CODE: 1520051102

DESCRIPTION: Aluminium body, G1" ports, pilot ratio 1:7, range 50-350 bar (725-5075 psi), std setting 280 bar (4060 psi) @ 5 l/min (1.32 US gpm)

For other configurations and steel body, please contact our Sales Dpt.

Rating diagrams

VOSL/SC 38 pressure drop vs. flow from D1->U1 and U1->D1

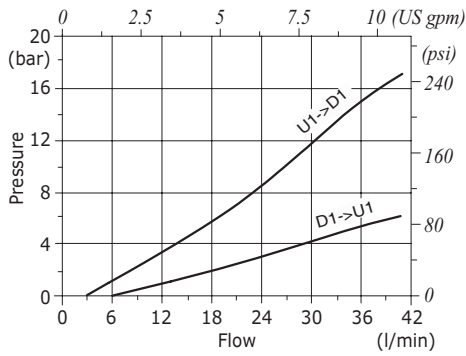

VOSL/SC 12 pressure drop vs. flow from D1->U1 and U1->D1

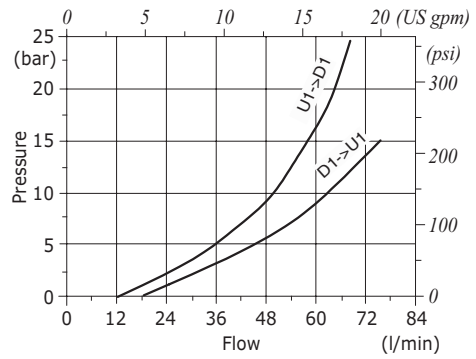

VOSL/SC 34 pressure drop vs. flow from D1->U1 and U1->D1

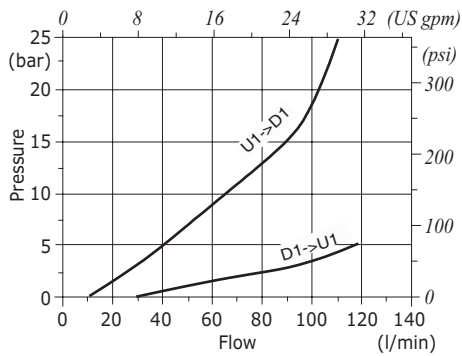

VOSL/SC 100 pressure drop vs. flow from D1->U1 and U1->D1

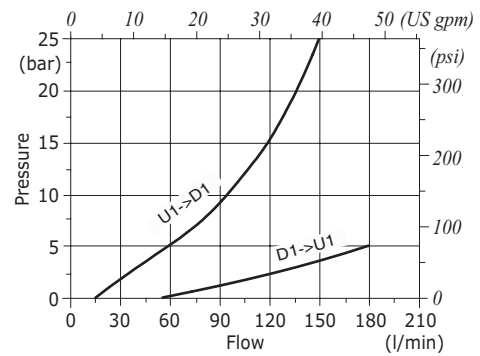



Type VOSL/SC/CC counterbalance valves

- Single acting

Technical specifications and diagrams are measured with mineral oil of 46 cSt viscosity at 40°C (104°F) temperature.

	VOSL/SC/CC 38	VOSL/SC/CC 12	VOSL/SC/CC 34	VOSL/SC/CC 100	
Nominal flow	40 l/min (10.6 US gpm)	75 l/min (19.8 US gpm)	120 l/min (31.7 US gpm)	180 l/min (47.6 US gpm)	
Max. pressure	Aluminium body = 210 bar (3050 psi) Steel body = 350 bar (5100 psi)				
Oil leakage	0.25 cm ³ /min - 0.015 in ³ /min. (5 drops) at 210 bar - 3050 psi at 80% of pressure setting				
Fluid	mineral based oil				
Viscosity	from 10 to 200 cSt				
Max. level of contamination	18/16/13 ISO4406				
Fluid temperature	with NBR seals from -20°C (-4°F) to 80°C (176°F)				
Environmental temp. for working conditions	from -40°C (-40°F) to 100°C (212°F)				
Weight	<i>aluminium</i>	0.83 kg (1.83 lb)	1.11 kg (2.45 lb)	1.53 kg (3.37 lb)	3.18 kg (7.01 lb)
	<i>steel</i>	1.56 kg (3.44 lb)	2.32 kg (5.11 lb)	3.39 kg (7.47 lb)	7.69 kg (16.9 lb)

NOTE - For different conditions, please contact Walvoil Sales Dpt.

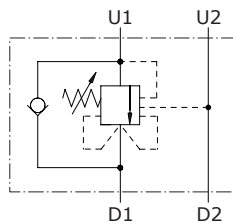

Dimensions

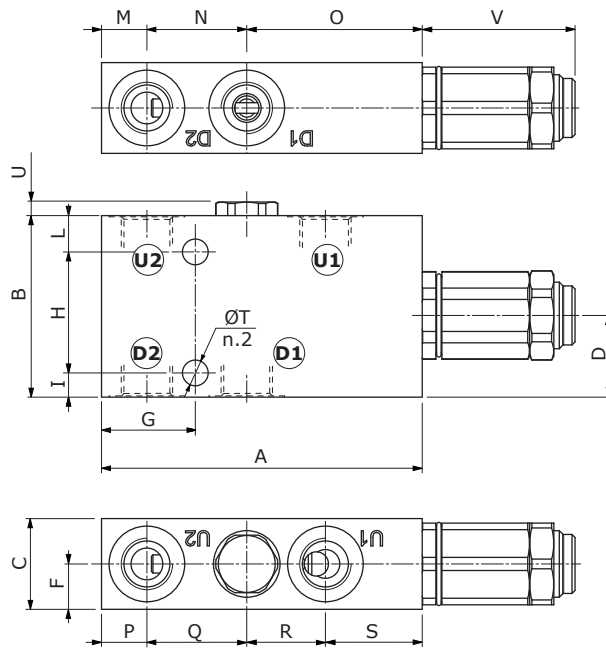

Valve type	D1	D2	U1	U2
VOSL/SC/CC 38	G3/8	G3/8	G3/8	G3/8
VOSL/SC/CC 12	G1/2	G1/2	G1/2	G1/2
VOSL/SC/CC 34	G3/4	G3/4	G3/4	G3/4
VOSL/SC/CC 100	G1"	G1"	G1"	G1"

Dimensions are in mm-in

Valve type	A	B	C	D	F	G	H	I	L	M	N	O	P	Q	R	S	ØT	U	V
VOSL/SC 38/CC	106	60	30	27	15	31	40	8	12	15	33	58	15	33	26	32	8.5	4.5	51
	4.17	2.36	1.18	1.06	0.89	1.22	1.57	0.315	0.472	0.59	1.30	2.28	0.59	1.30	1.02	1.26	0.335	0.177	2.01
VOSL/SC/CC 12	116	70	35	31	17.5	36	48	8	14	16	40	60	16	40	28	32	8.5	4.5	51
	4.57	2.76	1.38	1.22	0.69	1.42	1.89	0.315	0.55	0.63	1.57	2.36	0.63	1.57	1.10	1.26	0.335	0.177	2.01
VOSL/SC/CC 34	136	90	40	36	20	44	70	10	10	20	48	68	20	48	34	34	10.5	5.5	51
	5.35	3.54	1.57	1.42	0.79	1.73	2.76	0.394	0.394	0.79	1.89	2.68	0.79	1.89	1.34	1.34	0.413	0.217	2.01
VOSL/SC/CC 100	185	100	60	38	30	62	80	10	10	32	70	83	32	70	48	35	10.5	12.5	51
	7.28	3.94	2.36	1.50	1.18	2.44	3.15	0.394	0.394	1.26	2.76	3.27	1.26	2.76	1.89	1.38	0.413	0.492	2.01

Ordering codes

VOSL/SC/CC complete valves

TYPE: **VOSL/SC/CC 38/TR.S.p4.PG** CODE: 1525021102

DESCRIPTION: Aluminium body, G3/8 ports, pilot ratio 1:4, range 50-350 bar (725-5075 psi), std setting 280 bar (4060 psi) @ 5 l/min (1.32 US gpm)

TYPE: **VOSL/SC/CC 12/TR.S.p7.PG** CODE: 1525031102

DESCRIPTION: Aluminium body, G1/2 ports, pilot ratio 1:7, range 50-350 bar (725-5075 psi), std setting 280 bar (4060 psi) @ 5 l/min (1.32 US gpm)

TYPE: **VOSL/SC/CC 34/TR.S.p7.PG** CODE: 1525041102

DESCRIPTION: Aluminium body, G3/4 ports, pilot ratio 1:7, range 50-350 bar (725-5075 psi), std setting 280 bar (4060 psi) @ 5 l/min (1.32 US gpm)

TYPE: **VOSL/SC/CC 100/TR.S.p7.PG** CODE: 1525051102

DESCRIPTION: Aluminium body, G1" ports, pilot ratio 1:7, range 50-350 bar (725-5075 psi), std setting 280 bar (4060 psi) @ 5 l/min (1.32 US gpm)

For other configurations and steel body, please contact our Sales Dept.

VOSL/SC 38 pressure drop vs. flow from D1->U1 and U1->D1

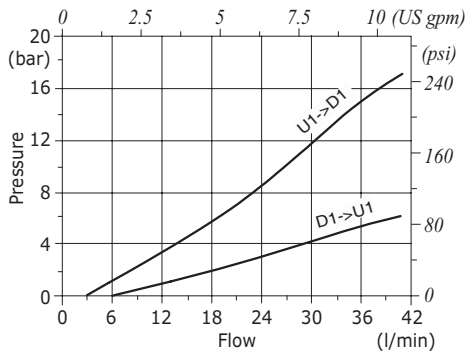

VOSL/SC 12 pressure drop vs. flow from D1->U1 and U1->D1

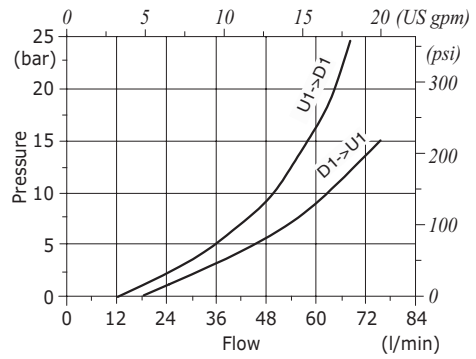

VOSL/SC 34 pressure drop vs. flow from D1->U1 and U1->D1

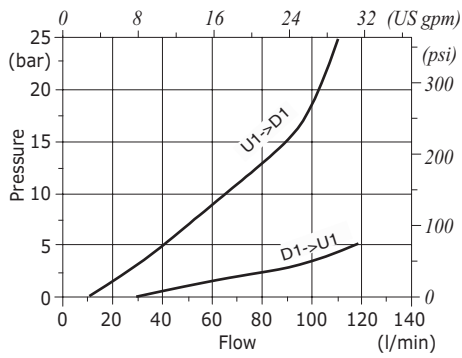

VOSL/SC 100 pressure drop vs. flow from D1->U1 and U1->D1

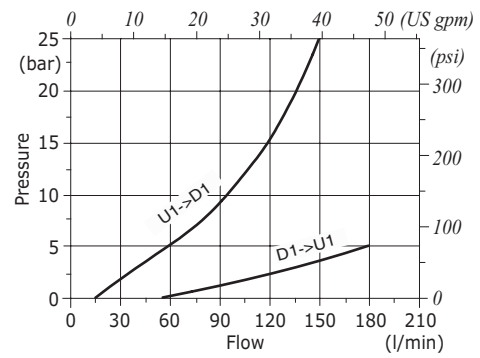



Type VOSLP counterbalance valves

- Single acting

Technical specifications and diagrams are measured with mineral oil of 46 cSt viscosity at 40°C (104°F) temperature.

	VOSLP 38	VOSLP 12	VOSLP 34	VOSLP 100	
Nominal flow	35 l/min (9.2 US gpm)	70 l/min (18.5 US gpm)	100 l/min (26.4 US gpm)	180 l/min (47.6 US gpm)	
Max. pressure	Aluminium body = 210 bar (3050 psi) Steel body = 350 bar (5100 psi)				
Oil leakage	0.25 cm ³ /min - 0.015 in ³ /min. (5 drops) at 210 bar - 3050 psi at 80% of pressure setting				
Fluid	mineral based oil				
Viscosity	from 10 to 200 cSt				
Max. level of contamination	18/16/13 ISO4406				
Fluid temperature	with NBR seals from -20°C (-4°F) to 80°C (176°F)				
Environmental temp. for working conditions	from -40°C (-40°F) to 100°C (212°F)				
Weight	aluminium	0.89 kg (1.96 lb)	0.97 kg (2.14 lb)	1.75 kg (3.86 lb)	2.90 kg (6.39 lb)
	steel	1.59 kg (3.51 lb)	1.88 kg (4.14 lb)	3.29 kg (7.25 lb)	6.18 kg (13.6 lb)

NOTE - For different conditions, please contact Walvoil Sales Dpt.

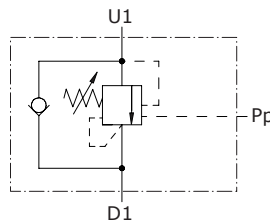

Dimensions

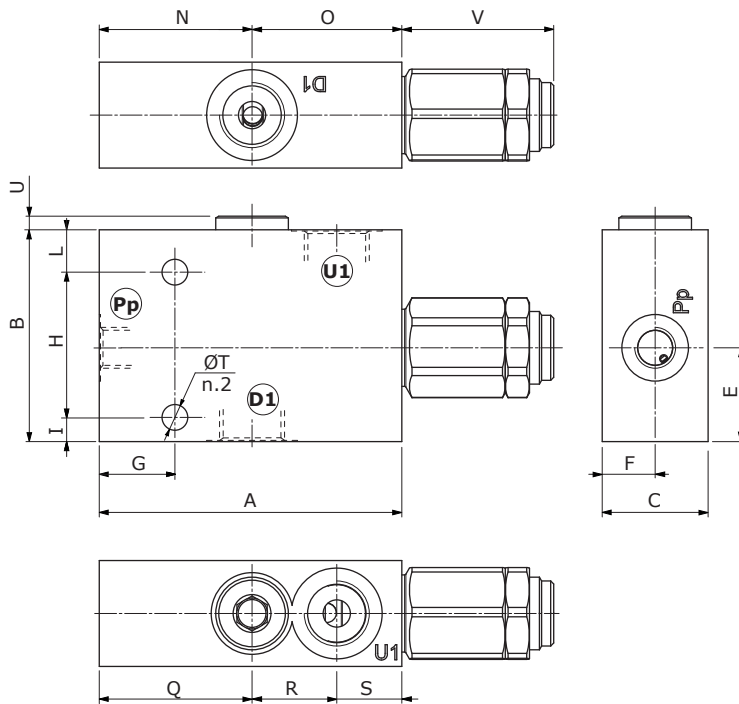

Valve type	D1	U1	Pp
VOSLP 38	G3/8	G1/4	G1/4
VOSLP 12	G1/2	G1/4	G1/4
VOSLP 34	G3/4	G1/4	G1/4
VOSLP 100	G1"	G1/4	G1/4

Dimensions are in mm-in

Valve type	A	B	C	E	F	G	H	I	L	N	O	Q	R	S	ØT	V
VOSLP 38	98 3.86	65 2.56	30 1.18	27 1.06	15 0.59	27 1.06	40 1.57	8 0.315	17 0.70	47 1.85	51 2.01	47 1.85	29 1.14	22 0.87	8.5 0.335	52 2.05
VOSLP 12	100 3.94	70 2.76	35 1.38	31 1.22	17.5 0.69	25 0.98	48 1.89	8 0.315	14 0.551	50.5 1.99	49.5 1.95	50.5 1.99	28 1.10	21.5 0.85	8.5 0.335	57 2.24
VOSLP 34	120 4.72	90 3.54	40 1.57	36 1.42	20 0.79	32 1.26	70 2.76	10 0.394	10 0.394	55 2.16	65 2.56	55 2.17	35 1.38	30 1.18	10.5 0.41	66 2.60
VOSLP 100	140 5.51	100 3.94	60 2.36	37 1.46	30 1.18	30 1.18	80 3.15	10 0.394	10 0.394	64 2.52	76 2.99	64 2.52	46 1.81	30 1.18	10.5 0.41	66 2.60

Ordering codes

VOSLP complete valves

TYPE: **VOSLP 38/TR.S.p4** CODE: 1530021102

DESCRIPTION: Aluminium body, G3/8 ports, pilot ratio 1:4, range 50-350 bar (725-5075 psi), std setting 280 bar (4060 psi) @ 5 l/min (1.32 US gpm)

TYPE: **VOSLP 12/TR.S.p7** CODE: 1530031102

DESCRIPTION: Aluminium body, G1/2 ports, pilot ratio 1:7, range 50-350 bar (725-5075 psi), std setting 280 bar (4060 psi) @ 5 l/min (1.32 US gpm)

TYPE: **VOSLP 34/TR.S.p7** CODE: 1530041102

DESCRIPTION: Aluminium body, G3/4 ports, pilot ratio 1:7, range 50-350 bar (725-5075 psi), std setting 280 bar (4060 psi) @ 5 l/min (1.32 US gpm)

TYPE: **VOSLP 100/TR.S.p7** CODE: 1530051102

DESCRIPTION: Aluminium body, G1" ports, pilot ratio 1:7, range 50-350 bar (725-5075 psi), std setting 280 bar (4060 psi) @ 5 l/min (1.32 US gpm)

For other configurations and steel body, please contact our Sales Dept.

VOSLP 38 pressure drop vs. flow from D1->U1 and U1->D1

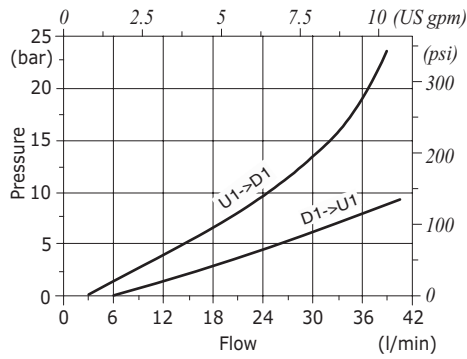

VOSLP 12 pressure drop vs. flow from D1->U1 and U1->D1

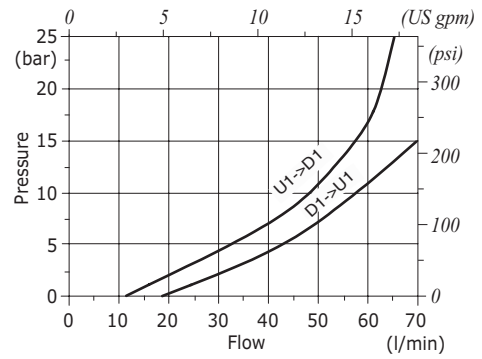

VOSLP 34 pressure drop vs. flow from D1->U1 and U1->D1

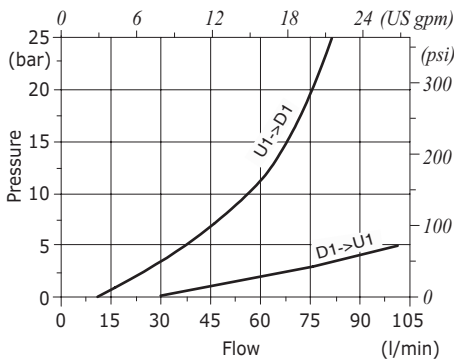

VOSLP 100 pressure drop vs. flow from D1->U1 and U1->D1

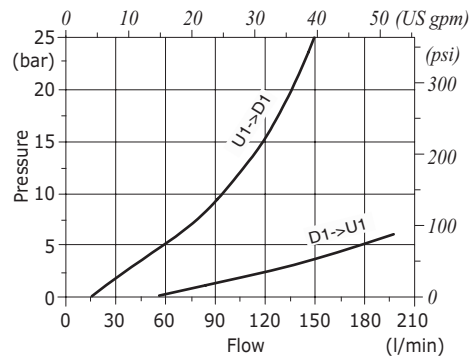



Type VOSLP/CC counterbalance valves

- Single acting
- Relief compensated

Technical specifications and diagrams are measured with mineral oil of 46 cSt viscosity at 40°C (104°F) temperature.

	VOSLP/CC 38	VOSLP/CC 12	VOSLP/CC 34	VOSLP/CC 100	
Nominal flow	35 l/min (9.2 US gpm)	70 l/min (18.5 US gpm)	100 l/min (26.4 US gpm)	180 l/min (47.6 US gpm)	
Max. pressure	Aluminium body = 210 bar (3050 psi) Steel body = 350 bar (5100 psi)				
Oil leakage	0.25 cm ³ /min - 0.015 in ³ /min. (5 drops) at 210 bar - 3050 psi at 80% of pressure setting				
Fluid	mineral based oil				
Viscosity	from 10 to 200 cSt				
Max. level of contamination	18/16/13 ISO4406				
Fluid temperature	with NBR seals from -20°C (-4°F) to 80°C (176°F)				
Environmental temp. for working conditions	from -40°C (-40°F) to 100°C (212°F)				
Weight	<i>aluminium</i>	1.01 kg (2.23 lb)	1.13 kg (2.49 lb)	1.83 kg (4.03 lb)	2.98 kg (6.57 lb)
	<i>steel</i>	1.70 kg (3.75 lb)	2.01 kg (4.43 lb)	3.37 kg (7.43 lb)	6.26 kg (13.8 lb)

NOTE - For different conditions, please contact Walvoil Sales Dpt.

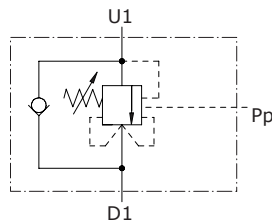

Dimensions

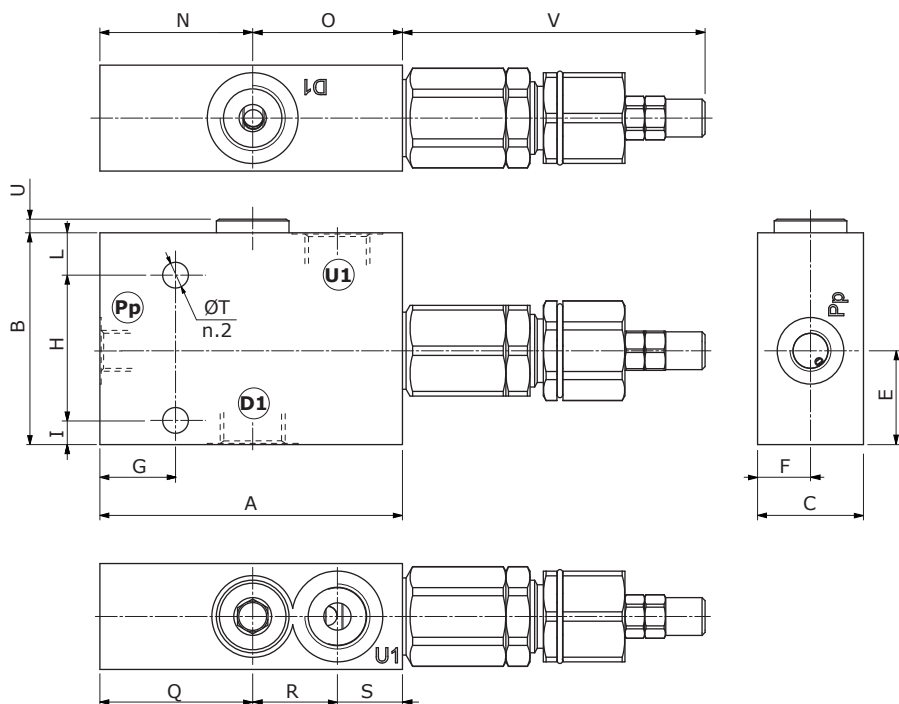

Valve type	D1	U1	Pp
VOSLP/CC 38	G3/8	G1/4	G1/4
VOSLP/CC 12	G1/2	G1/4	G1/4
VOSLP/CC 34	G3/4	G1/4	G1/4
VOSLP/CC 100	G1"	G1/4	G1/4

Dimensions are in mm-in

Valve type	A	B	C	E	F	G	H	I	L	N	O	Q	R	S	ØT	V
VOSLP/CC 38	98 3.86	65 2.56	30 1.18	27 1.06	15 0.59	27 1.06	40 1.57	8 0.315	17 0.70	47 1.85	51 2.01	47 1.85	29 1.14	22 0.87	8.5 0.335	92.2 3.63
VOSLP/CC 12	100 3.94	70 2.76	35 1.38	31 1.22	17.5 0.69	25 0.98	48 1.89	8 0.315	14 0.551	50.5 1.99	49.5 1.95	50.5 1.99	28 1.10	21.5 0.85	8.5 0.335	99.7 3.93
VOSLP/CC 34	120 4.72	90 3.54	40 1.57	36 1.42	20 0.79	32 1.26	70 2.76	10 0.394	10 0.394	55 2.16	65 2.56	55 2.17	35 1.38	30 1.18	10.5 0.41	101.7 4.00
VOSLP/CC 100	140 5.51	100 3.94	60 2.36	37 1.46	30 1.18	30 1.18	80 3.15	10 0.394	10 0.394	64 2.52	76 2.99	64 2.52	46 1.81	30 1.18	10.5 0.41	101.7 4.00

Ordering codes

VOSLP/CC complete valves

TYPE: **VOSLP/CC 38/TR.S.p4** CODE: 1534921100

DESCRIPTION: Aluminium body, G3/8 ports, pilot ratio 1:4, range 50-350 bar (725-5075 psi), std setting 280 bar (4060 psi) @ 5 l/min (1.32 US gpm)

TYPE: **VOSLP/CC 12/TR.S.p7** CODE: 1534931100

DESCRIPTION: Aluminium body, G1/2 ports, pilot ratio 1:7, range 50-350 bar (725-5075 psi), std setting 280 bar (4060 psi) @ 5 l/min (1.32 US gpm)

TYPE: **VOSLP/CC 34/TR.S.p7** CODE: 1534941100

DESCRIPTION: Aluminium body, G3/4 ports, pilot ratio 1:7, range 50-350 bar (725-5075 psi), std setting 280 bar (4060 psi) @ 5 l/min (1.32 US gpm)

TYPE: **VOSLP/CC 100/TR.S.p7** CODE: 1534951100

DESCRIPTION: Aluminium body, G1" ports, pilot ratio 1:7, range 50-350 bar (725-5075 psi), std setting 280 bar (4060 psi) @ 5 l/min (1.32 US gpm)

For other configurations and steel body, please contact our Sales Dept.

VOSLP/CC 38 pressure drop vs. flow from D1->U1 and U1->D1

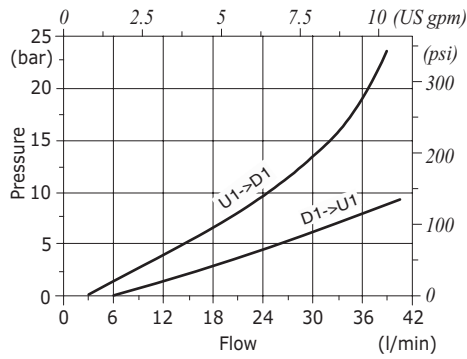

VOSLP/CC 12 pressure drop vs. flow from D1->U1 and U1->D1

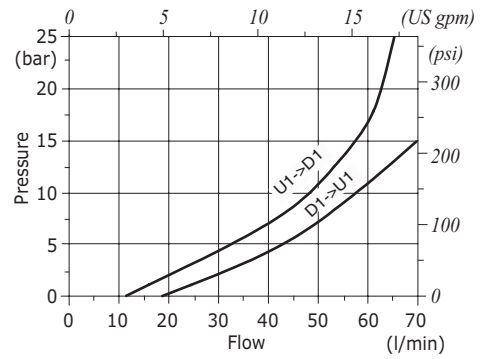

VOSLP/CC 34 pressure drop vs. flow from D1->U1 and U1->D1

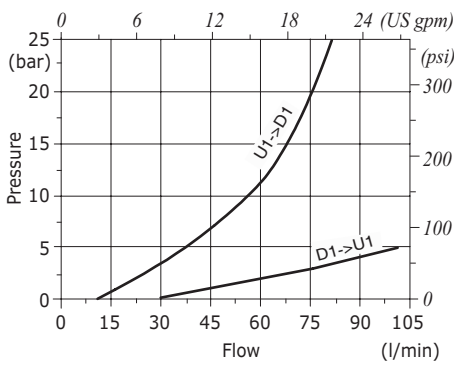

VOSLP/CC 100 pressure drop vs. flow from D1->U1 and U1->D1

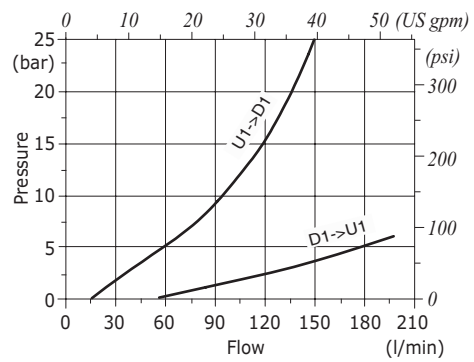



Type VOSLP/SC counterbalance valves

- Single acting
- Load sensitive

Technical specifications and diagrams are measured with mineral oil of 46 cSt viscosity at 40°C (104°F) temperature.

	VOSLP/SC 38	VOSLP/SC 12	VOSLP/SC 34	VOSLP/SC 100	
Nominal flow	40 l/min (10.6 US gpm)	75 l/min (19.8 US gpm)	120 l/min (31.7 US gpm)	180 l/min (47.6 US gpm)	
Max. pressure	Aluminium body = 210 bar (3050 psi) Steel body = 350 bar (5100 psi)				
Oil leakage	0.25 cm ³ /min - 0.015 in ³ /min. (5 drops) at 210 bar - 3050 psi at 80% of pressure setting				
Fluid	mineral based oil				
Viscosity	from 10 to 200 cSt				
Max. level of contamination	18/16/13 ISO4406				
Fluid temperature	with NBR seals from -20°C (-4°F) to 80°C (176°F)				
Environmental temp. for working conditions	from -40°C (-40°F) to 100°C (212°F)				
Weight	<i>aluminium</i>	0.68 kg (1.50 lb)	0.95 kg (2.09 lb)	1.40 kg (3.09 lb)	2.70 kg (5.95 lb)
	<i>steel</i>	1.41 kg (3.11 lb)	2.03 kg (4.47 lb)	3.20 kg (7.05 lb)	6.52 kg (14.37 lb)

NOTE - For different conditions, please contact Walvoil Sales Dpt.

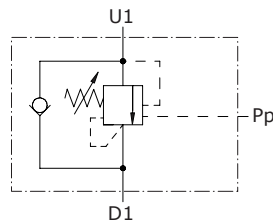

Dimensions

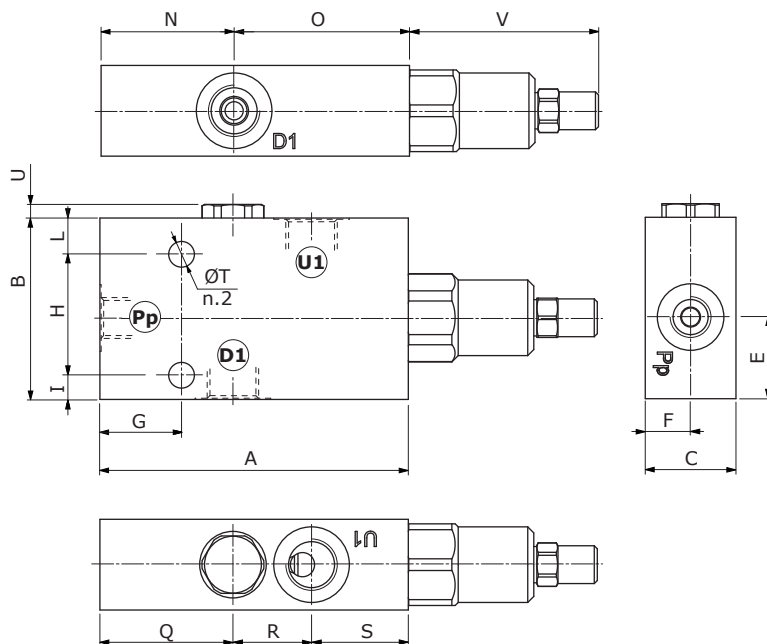

Valve type	D1	U1	Pp
VOSLP/SC 38	G3/8	G1/4	G1/4
VOSLP/SC 12	G1/2	G1/4	G1/4
VOSLP/SC 34	G3/4	G1/4	G1/4
VOSLP/SC 100	G1"	G1/4	G1/4

Dimensions are in mm-in

Valve type	A	B	C	E	F	G	H	I	L	N	O	Q	R	S	$\varnothing T$	V
VOSLP/SC 38	102 4.02	60 2.36	30 1.18	27 1.06	15 0.59	27 1.06	40 1.57	8 0.315	12 0.472	44 1.73	58 2.28	44 1.73	26 1.02	32 1.26	8.5 0.335	62.5 2.46
VOSLP/SC 12	110 4.33	70 2.76	35 1.38	31 1.22	17.5 0.69	30 1.18	48 1.89	8 0.315	14 0.551	50 1.97	60 2.36	50 1.97	28 1.10	32 1.26	8.5 0.335	63.5 2.48
VOSLP/SC 34	123 4.84	90 3.54	40 1.57	36 1.42	20 0.78	31 1.22	70 2.76	10 0.394	10 0.394	55 2.17	68 2.68	55 2.17	34 1.34	34 1.34	10.5 0.413	63.5 2.48
VOSLP/SC 100	153 6.02	100 3.94	30 1.18	38 1.38	30 1.18	37 1.46	80 3.15	10 0.394	10 0.394	70 2.76	83 3.27	70 2.76	48 1.89	35 1.38	10.5 0.413	63.5 2.48

Ordering codes

VOSLP/SC complete valves

TYPE: **VOSLP/SC 38/TR.S.p4** CODE: 1540021102
 DESCRIPTION: Aluminium body, G3/8 ports, pilot ratio 1:4, range 50-350 bar (725-5075 psi), std setting 280 bar (4060 psi) @ 5 l/min (1.32 US gpm)

TYPE: **VOSLP/SC 12/TR.S.p7** CODE: 1540031102
 DESCRIPTION: Aluminium body, G1/2 ports, pilot ratio 1:7, range 50-350 bar (725-5075 psi), std setting 280 bar (4060 psi) @ 5 l/min (1.32 US gpm)

TYPE: **VOSLP/SC 34/TR.S.p7** CODE: 1540041102
 DESCRIPTION: Aluminium body, G3/4 ports, pilot ratio 1:7, range 50-350 bar (725-5075 psi), std setting 280 bar (4060 psi) @ 5 l/min (1.32 US gpm)

TYPE: **VOSLP/SC 100/TR.S.p7** CODE: 1540051102
 DESCRIPTION: Aluminium body, G1" ports, pilot ratio 1:7, range 50-350 bar (725-5075 psi), std setting 280 bar (4060 psi) @ 5 l/min (1.32 US gpm)

For other configurations and steel body, please contact our Sales Dept.

VOSLP/SC 38 pressure drop vs. flow from D1->U1 and U1->D1

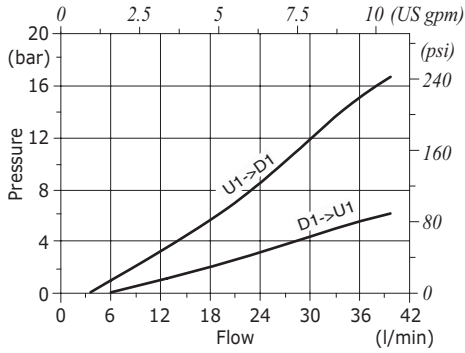

VOSLP/SC 12 pressure drop vs. flow from D1->U1 and U1->D1

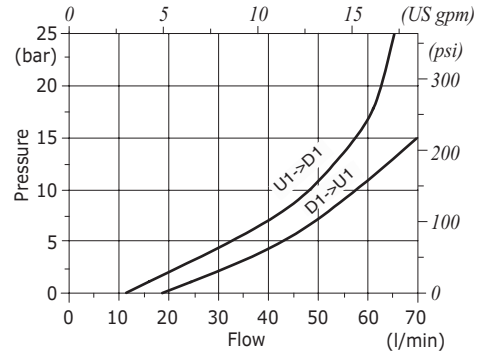

VOSLP/SC 34 pressure drop vs. flow from D1->U1 and U1->D1

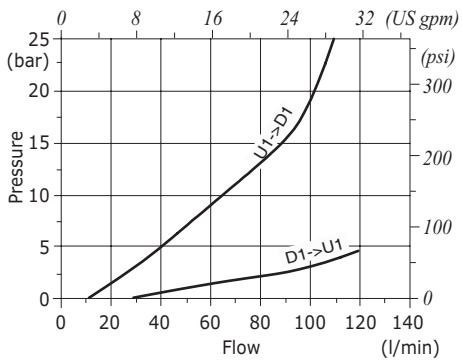

VOSLP/SC 100 pressure drop vs. flow from D1->U1 and U1->D1

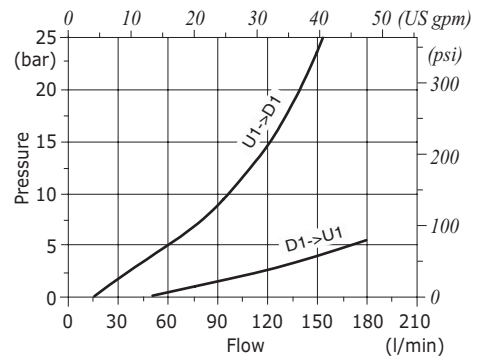



Type VOSLP/SC/RO counterbalance valves

- Single acting
- Load sensitive
- Bolt connection

Technical specifications and diagrams are measured with mineral oil of 46 cSt viscosity at 40°C (104°F) temperature.

	VOSLP/SC/RO 38	VOSLP/SC/RO 12	VOSLP/SC/RO 34	VOSLP/SC/RO 100	
Nominal flow	40 l/min (10.6 US gpm)	75 l/min (19.8 US gpm)	120 l/min (31.7 US gpm)	180 l/min (47.6 US gpm)	
Max. pressure	Aluminium body = 210 bar (3050 psi) Steel body = 350 bar (5100 psi)				
Oil leakage	0.25 cm ³ /min - 0.015 in ³ /min. (5 drops) at 210 bar - 3050 psi at 80% of pressure setting				
Fluid	mineral based oil				
Viscosity	from 10 to 200 cSt				
Max. level of contamination	18/16/13 ISO4406				
Fluid temperature	with NBR seals from -20°C (-4°F) to 80°C (176°F)				
Environmental temp. for working conditions	from -40°C (-40°F) to 100°C (212°F)				
Weight	<i>aluminium</i>	0.87 kg (1.91 lb)	1.19 kg (2.62 lb)	1.57 kg (3.46 lb)	3.19 kg (7.03 lb)
	<i>steel</i>	1.61 kg (3.55 lb)	2.24 kg (4.94 lb)	3.17 kg (7.19 lb)	6.91 kg (15.23 lb)

NOTE - For different conditions, please contact Walvoil Sales Dpt.

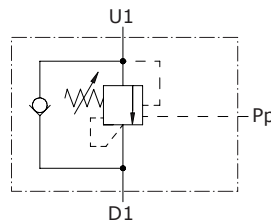

Dimensions

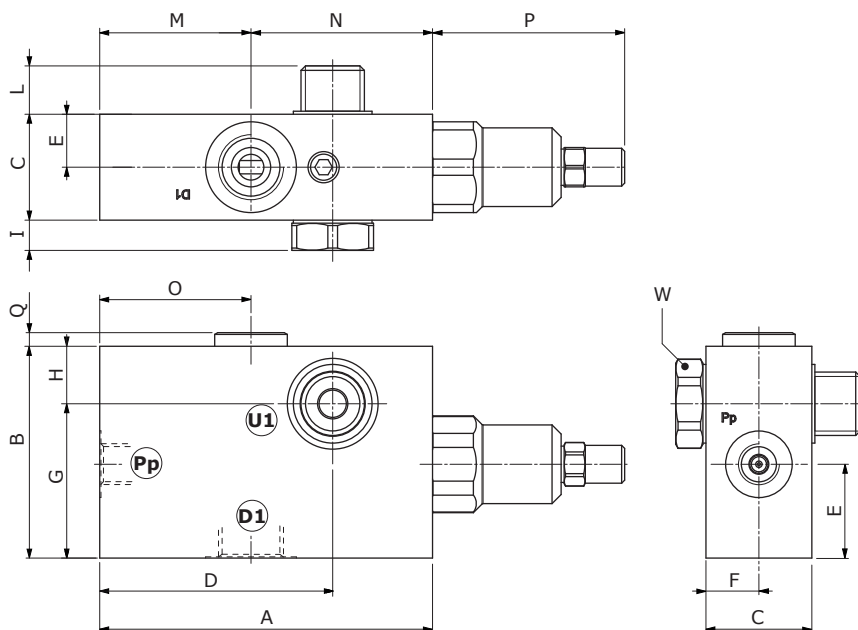

Valve type	D1 female	U1 male	Pp
VOSLP/SC/RO 38	G3/8	G3/8	G1/4
VOSLP/SC/RO 12	G1/2	G1/2	G1/4
VOSLP/SC/RO 34	G3/4	G3/4	G1/4
VOSLP/SC/RO 100	G1"	G1"	G1/4

Dimensions are in mm-in

Valve type	A	B	C	D	E	F	G	H	I	L	M	N	O	P	Q	W
VOSLP/SC/RO 38	102 4.02	60 2.36	30 1.18	68 2.68	27 1.06	15 0.59	44 1.73	16 0.63	9 0.354	22 0.87	44 1.73	58 2.28	44 1.73	62.5 2.46	4.5 0.177	22 0.87
VOSLP/SC/RO 12	110 4.33	70 2.76	35 1.38	77 3.03	31 1.22	17.5 0.68	51 2.01	19 0.75	10 0.394	16 0.63	50 1.97	60 2.36	50 1.97	63.5 2.50	4.5 0.177	27 1.06
VOSLP/SC/RO 34	116 4.57	90 3.54	40 1.57	84 3.31	36 1.42	20 0.79	61 2.40	29 1.14	10 0.394	17 0.67	48 1.89	68 2.68	48 1.89	63.5 2.50	5.5 0.217	32 1.26
VOSLP/SC/RO 100	153 6.02	100 3.94	60 2.36	118 4.65	38 1.50	30 1.18	69 2.72	31 1.22	12 0.472	22 0.87	70 2.76	73 2.87	70 2.76	63.5 2.50	12.5 0.492	41 1.61

Ordering codes

VOSLP/SC/RO complete valves

TYPE: **VOSLP/SC/RO 38/TR.S.p4.PG** CODE: 1544021102
 DESCRIPTION: Aluminium body, G3/8 ports, pilot ratio 1:4, range 50-350 bar (725-5075 psi), std setting 280 bar (4060 psi) @ 5 l/min (1.32 US gpm)

TYPE: **VOSLP/SC/RO 12/TR.S.p7.PG** CODE: 1544031102
 DESCRIPTION: Aluminium body, G1/2 ports, pilot ratio 1:7, range 50-350 bar (725-5075 psi), std setting 280 bar (4060 psi) @ 5 l/min (1.32 US gpm)

TYPE: **VOSLP/SC/RO 34/TR.S.p7.PG** CODE: 1544041102
 DESCRIPTION: Aluminium body, G3/4 ports, pilot ratio 1:7, range 50-350 bar (725-5075 psi), std setting 280 bar (4060 psi) @ 5 l/min (1.32 US gpm)

TYPE: **VOSLP/SC/RO 100/TR.S.p7.PG** CODE: 1544051106
 DESCRIPTION: Aluminium body, G1" ports, pilot ratio 1:7, range 50-350 bar (725-5075 psi), std setting 280 bar (4060 psi) @ 5 l/min (1.32 US gpm)

For other configurations and steel body, please contact our Sales Dept.

VOSLP/SC/RO 38 pressure drop vs. flow from D1->U1 and U1->D1

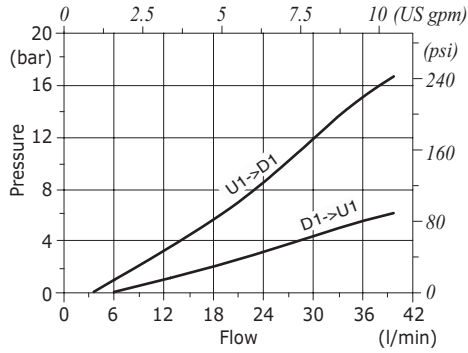

VOSLP/SC/RO 12 pressure drop vs. flow from D1->U1 and U1->D1

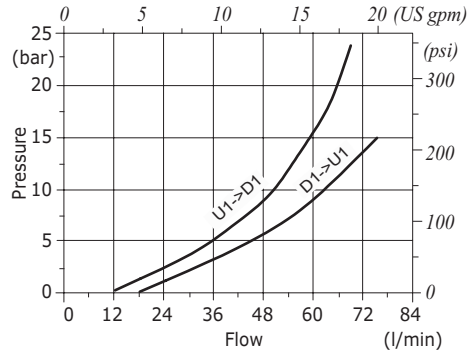

VOSLP/SC/RO 34 pressure drop vs. flow from D1->U1 and U1->D1

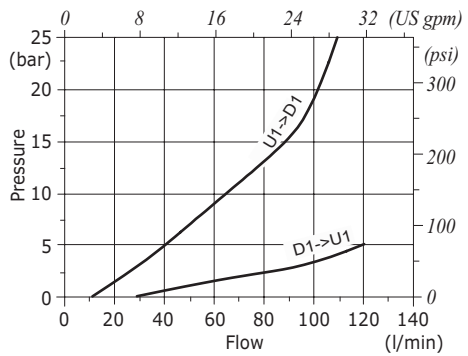

VOSLP/SC/RO 100 pressure drop vs. flow from D1->U1 and U1->D1

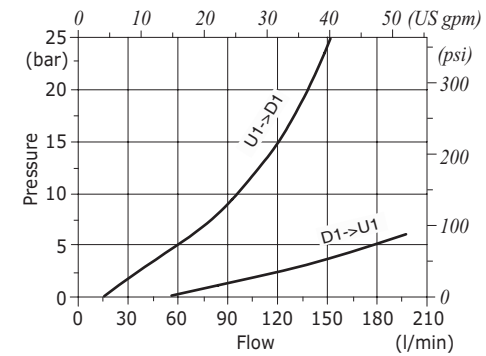



Type VOSLP/SC/CC counterbalance valves

- Single acting
- Relief compensated

Technical specifications and diagrams are measured with mineral oil of 46 cSt viscosity at 40°C (104°F) temperature.

	VOSLP/SC/CC 38	VOSLP/SC/CC 12	VOSLP/SC/CC 34	VOSLP/SC/CC 100	
Nominal flow	40 l/min (10.6 US gpm)	75 l/min (19.8 US gpm)	120 l/min (31.7 US gpm)	180 l/min (47.6 US gpm)	
Max. pressure	Aluminium body = 210 bar (3050 psi) Steel body = 350 bar (5100 psi)				
Oil leakage	0.25 cm ³ /min - 0.015 in ³ /min. (5 drops) at 210 bar - 3050 psi at 80% of pressure setting				
Fluid	mineral based oil				
Viscosity	from 10 to 200 cSt				
Max. level of contamination	18/16/13 ISO4406				
Fluid temperature	with NBR seals from -20°C (-4°F) to 80°C (176°F)				
Environmental temp. for working conditions	from -40°C (-40°F) to 100°C (212°F)				
Weight	aluminium	0.82 kg (1.81 lb)	1.10 kg (2.43 lb)	1.45 kg (3.20 lb)	2.78 kg (6.13 lb)
	steel	1.93 kg (4.25 lb)	2.20 kg (485 lb)	3.24 kg (7.14 lb)	6.64 kg (14.6 lb)

NOTE - For different conditions, please contact Walvoil Sales Dpt.

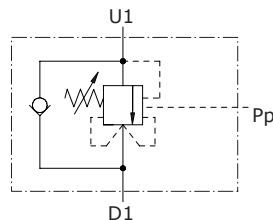

Dimensions

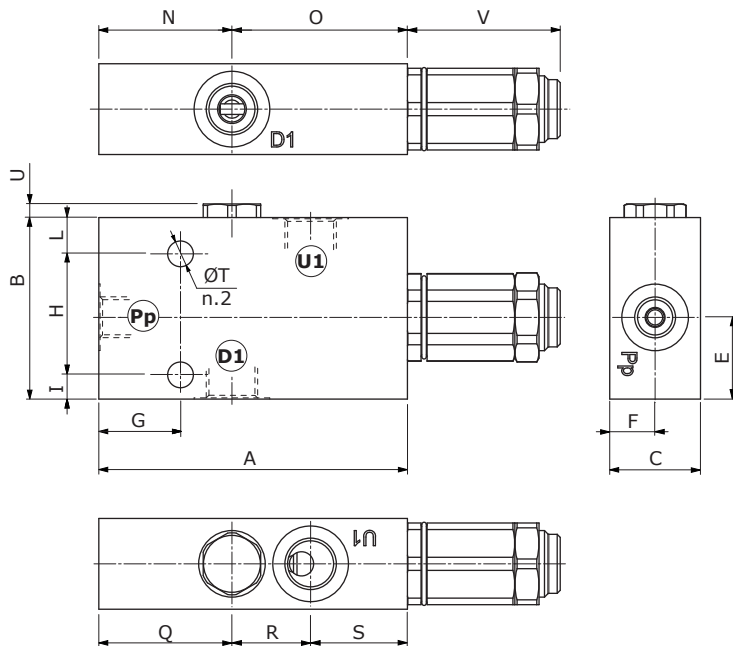

Valve type	ØD1	U1	Pp
VOSLP/SC/CC 38	G3/8	G1/4	G1/4
VOSLP/SC/CC 12	G1/2	G1/4	G1/4
VOSLP/SC/CC 34	G3/4	G1/4	G1/4
VOSLP/SC/CC 100	G1"	G1/4	G1/4

Dimensions are in mm-in

Valve type	A	B	C	E	F	G	H	I	L	N	O	Q	R	S	ØT	V
VOSLP/SC/CC 38	102	60	30	27	15	27	40	8	12	44	58	44	26	32	8.5	50.5
	4.02	2.36	1.18	1.06	0.59	1.06	1.57	0.315	0.472	1.73	2.28	1.73	1.02	1.26	0.335	1.99
VOSLP/SC/CC 12	110	70	35	31	17.5	30	48	8	14	50	60	50	28	32	8.5	50.5
	4.33	2.76	1.38	1.22	0.69	1.18	1.89	0.315	0.551	1.97	2.36	1.97	1.10	1.26	0.335	1.99
VOSLP/SC/CC 34	123	90	40	36	20	31	70	10	10	55	68	55	34	34	10.5	50.5
	4.84	3.54	1.57	1.42	0.78	1.22	2.76	0.394	0.394	2.17	2.68	2.17	1.34	1.34	0.413	1.99
VOSLP/SC/CC 100	153	100	30	38	30	37	80	10	10	70	83	70	48	35	10.5	50.5
	6.02	3.94	1.18	1.38	1.18	1.46	3.15	0.394	0.394	2.76	3.27	2.76	1.89	1.38	0.413	1.99

Ordering codes

VOSLP/SC/CC complete valves

TYPE: **VOSLP/SC/CC 38/TR.S.p4.PG** CODE: 1545021102
 DESCRIPTION: Aluminium body, G3/8 ports, pilot ratio 1:4, range 50-350 bar (725-5075 psi), std setting 280 bar (4060 psi) @ 5 l/min (1.32 US gpm)

TYPE: **VOSLP/SC/CC 12/TR.S.p7.PG** CODE: 1545031102
 DESCRIPTION: Aluminium body, G1/2 ports, pilot ratio 1:7, range 50-350 bar (725-5075 psi), std setting 280 bar (4060 psi) @ 5 l/min (1.32 US gpm)

TYPE: **VOSLP/SC/CC 34/TR.S.p7.PG** CODE: 1545041102
 DESCRIPTION: Aluminium body, G3/4 ports, pilot ratio 1:7, range 50-350 bar (725-5075 psi), std setting 280 bar (4060 psi) @ 5 l/min (1.32 US gpm)

TYPE: **VOSLP/SC/CC 100/TR.S.p7.PG** CODE: 1545051102
 DESCRIPTION: Aluminium body, G1" ports, pilot ratio 1:7, range 50-350 bar (725-5075 psi), std setting 280 bar (4060 psi) @ 5 l/min (1.32 US gpm)

For other configurations and steel body, please contact our Sales Dept.

VOSLP/SC/CC 38 pressure drop vs. flow from D1->U1 and U1->D1

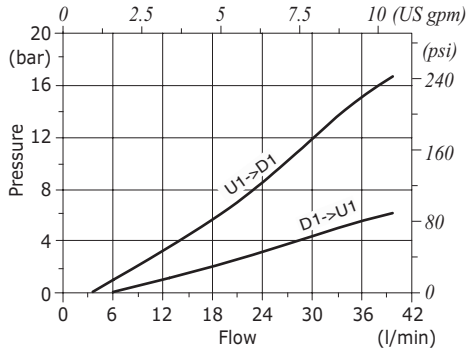

VOSLP/SC/CC 12 pressure drop vs. flow from D1->U1 and U1->D1

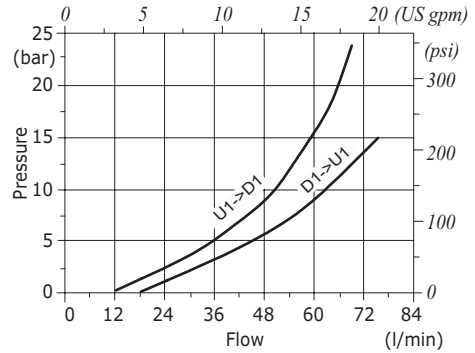

VOSLP/SC/CC 34 pressure drop vs. flow from D1->U1 and U1->D1

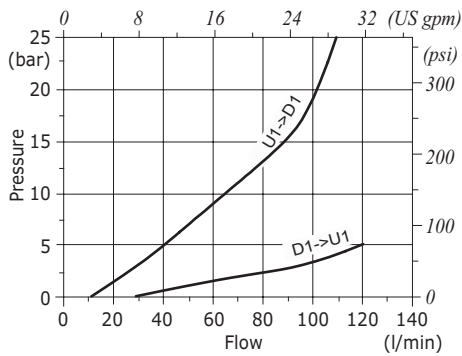

VOSLP/SC/CC 100 pressure drop vs. flow from D1->U1 and U1->D1

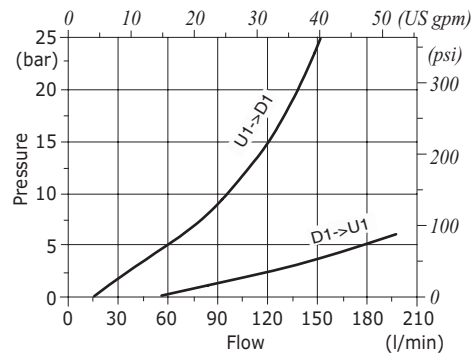



Type VOSL/ML counterbalance valves

- Single acting
- Load sensitive
- Flange assembling according to ISO 4401:2005 (CETOP)

Technical specifications and diagrams are measured with mineral oil of 46 cSt viscosity at 40°C (104°F) temperature.

	VOSL/ML 6-38	VOSL/ML 10-12
Nominal flow	35 l/min (9.2 US gpm)	70 l/min (18.5 US gpm)
Max. pressure	Aluminium body = 210 bar (3050 psi) Steel body = 350 bar (5100 psi)	
Oil leakage	0.25 cm ³ /min - 0.015 in ³ /min. (5 drops) at 210 bar - 3050 psi at 80% of pressure setting	
Fluid	mineral based oil	
Viscosity	from 10 to 200 cSt	
Max. level of contamination	18/16/13 ISO4406	
Fluid temperature	with NBR seals from -20°C (-4°F) to 80°C (176°F)	
Environmental temp. for working conditions	from -40°C (-40°F) to 100°C (212°F)	
Weight	aluminium	1.27 kg (2.80 lb)
	steel	2.68 kg (5.91 lb)
		2.27 kg (5.00 lb)
		5.46 kg (12.04 lb)

NOTE - For different conditions, please contact Walvoil Sales Dpt.

VOSL/ML 6-38A

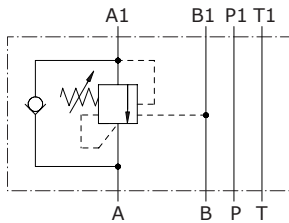

VOSL/ML 10-12A

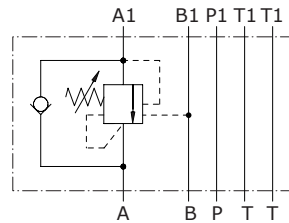

VOSL/ML 6-38B

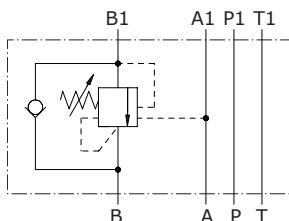

VOSL/ML 10-12B

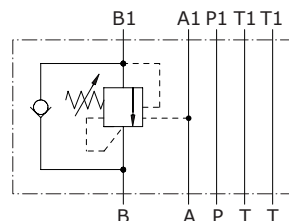

Dimensions

VOSL/ML 6-38A

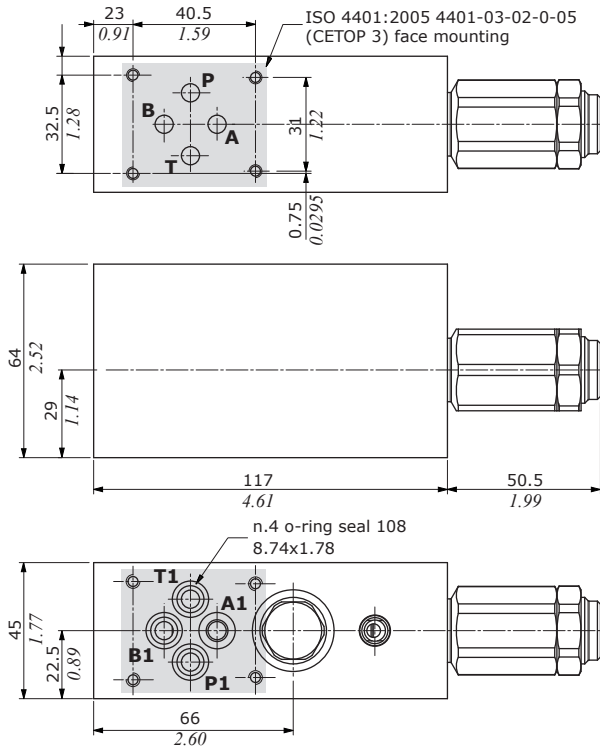

VOSL/ML 10-12A

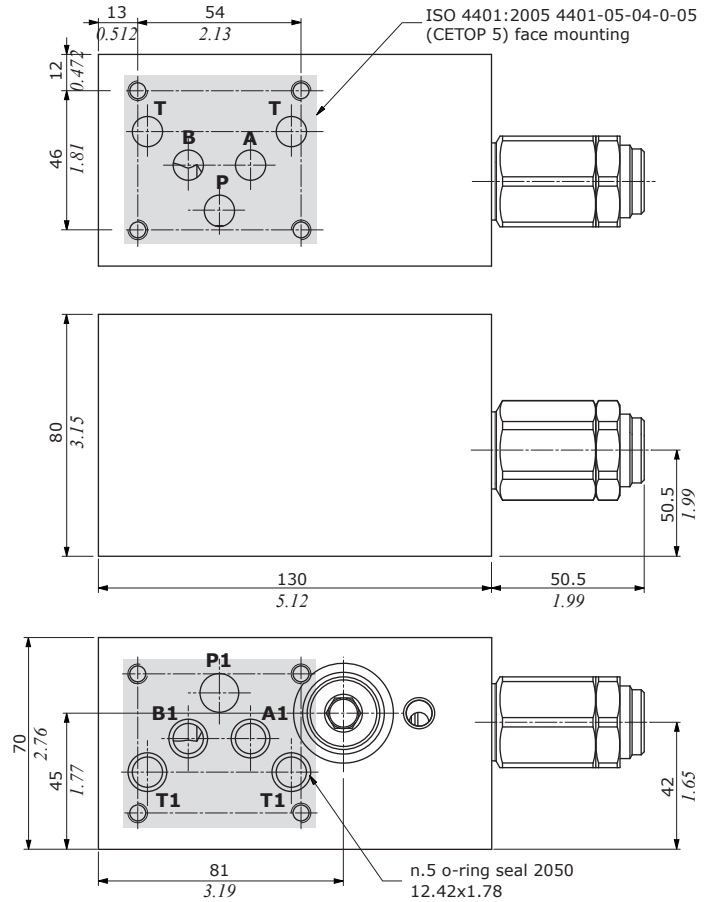

VOSL/ML 6-38B

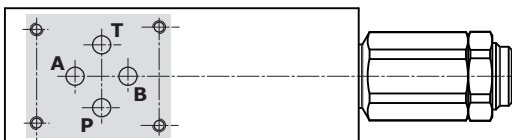

VOSL/ML 10-12B

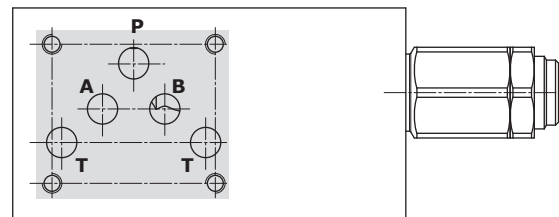

Ordering codes

VOSL/ML complete valves

- TYPE: **VOSL/ML 6-38A/TR.S.p4** CODE: 1518021802
 DESCRIPTION: Aluminium body, CETOP 3 flange, pilot ratio 1:4, range 50-350 bar (725-5075 psi), std setting 280 bar (4060 psi) @ 5 l/min (1.32 US gpm)
- TYPE: **VOSL/ML 6-38B/TR.S.p4** CODE: 1518021808
 DESCRIPTION: Aluminium body, CETOP 3 flange, pilot ratio 1:4, range 50-350 bar (725-5075 psi), std setting 280 bar (4060 psi) @ 5 l/min (1.32 US gpm)
- TYPE: **VOSL/ML 10-12A/TR.S.p7.PG** CODE: 1518031802
 DESCRIPTION: Aluminium body, CETOP 5 flange, pilot ratio 1:7, range 50-350 bar (725-5075 psi), std setting 280 bar (4060 psi) @ 5 l/min (1.32 US gpm)
- TYPE: **VOSL/ML 10-12B/TR.S.p7.PG** CODE: 1518031808
 DESCRIPTION: Aluminium body, CETOP 5 flange, pilot ratio 1:7, range 50-350 bar (725-5075 psi), std setting 280 bar (4060 psi) @ 5 l/min (1.32 US gpm)
- For other configurations and steel body, please contact our Sales Dept.

VOSL/ML 6-38 pressure drop vs. flow from A->A1 (B1->B) and A1->A (B1->B)

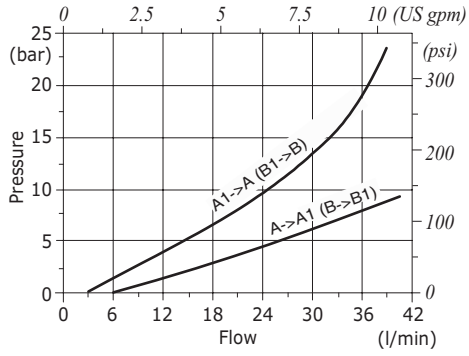

VOSL/ML 10-12 pressure drop vs. flow from A->A1 (B->B1) and A1->A (B1->B)

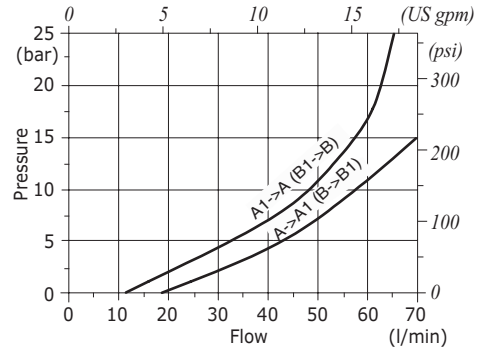



Type VODL counterbalance valves

- Double acting
- Load sensitive

Technical specifications and diagrams are measured with mineral oil of 46 cSt viscosity at 40°C (104°F) temperature.

	VODL 38	VODL 12	VODL 34	VODL 100	
Nominal flow	35 l/min (9.2 US gpm)	70 l/min (18.5 US gpm)	100 l/min (26.4 US gpm)	180 l/min (47.6 US gpm)	
Max. pressure	Aluminium body = 210 bar (3050 psi) Steel body = 350 bar (5100 psi)				
Oil leakage	0.25 cm ³ /min - 0.015 in ³ /min. (5 drops) at 210 bar - 3050 psi at 80% of pressure setting				
Fluid	mineral based oil				
Viscosity	from 10 to 200 cSt				
Max. level of contamination	18/16/13 ISO4406				
Fluid temperature	with NBR seals from -20°C (-4°F) to 80°C (176°F)				
Environmental temp. for working conditions	from -40°C (-40°F) to 100°C (212°F)				
Weight	aluminium	1.32 kg (2.91 lb)	1.69 kg (3.73 lb)	2.92 kg (6.44 lb)	4.75 kg (10.47 lb)
	steel	2.39 kg (5.27 lb)	2.95 kg (6.50 lb)	5.13 kg (11.31 lb)	9.60 kg (21.16 lb)

NOTE - For different conditions, please contact Walvoil Sales Dpt.

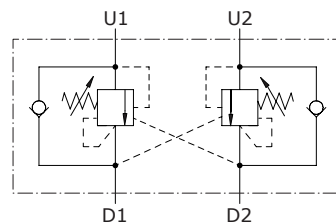

Dimensions

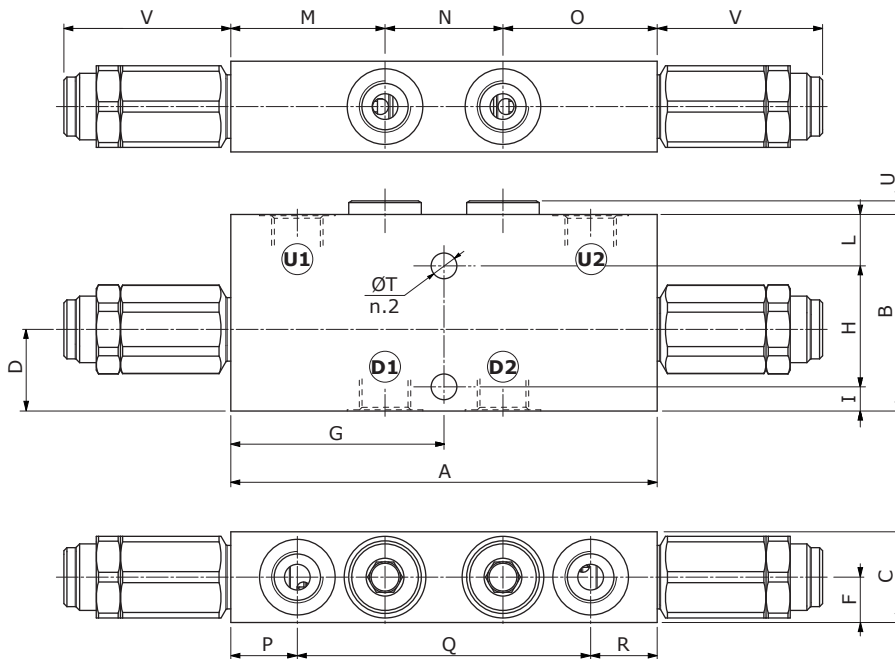

Valve type	D1	D2	U1	U2
VODL 38	G3/8	G3/8		
VODL 12	G1/2	G1/2		
VODL 34	G3/4	G3/4		
VODL 100	G1"	G1"		

Dimensions are in mm-in

Valve type	A	B	C	F	G	H	I	L	M	N	O	P	Q	R	ØT	U	V
VODL 38	141	65	30	15	70.5	40	8	17	51	39	51	22	97	22	8.5	4.5	55
	5.55	2.56	1.18	0.59	2.76	1.57	0.315	0.67	2.01	1.54	2.01	0.87	3.82	0.87	0.335	0.177	2.17
VODL 12	149	70	34.5	17.25	74.5	48	8	14	50.5	48	50.5	21.5	106	21.5	8.5	4.5	50.5
	5.87	2.76	1.36	0.68	2.93	1.89	0.315	0.551	1.99	1.89	1.99	0.85	4.17	0.85	0.335	0.177	1.99
VODL 34	184	90	40	20	92	70	10	10	65	54	65	30	124	30	10.5	5.5	61
	7.25	3.54	1.57	0.79	3.62	2.76	0.394	0.394	2.56	2.13	2.56	1.18	4.88	1.18	0.413	0.217	2.40
VODL 100	218	100	60	30	109	80	10	10	76	66	76	30	158	30	10.5	12.5	61
	8.58	3.94	2.36	1.18	4.29	3.15	0.394	0.394	2.99	2.60	2.99	1.18	6.22	1.18	0.413	0.492	2.40

Ordering codes

VODL complete valves

TYPE: **VODL 38/TR.S.p4** CODE: 1550021102

DESCRIPTION: Aluminium body, G3/8 ports, pilot ratio 1:4, range 50-350 bar (725-5075 psi), std setting 280 bar (4060 psi) @ 5 l/min (1.32 US gpm)

TYPE: **VODL 12/TR.S.p7** CODE: 1550031102

DESCRIPTION: Aluminium body, G1/2 ports, pilot ratio 1:7, range 50-350 bar (725-5075 psi), std setting 280 bar (4060 psi) @ 5 l/min (1.32 US gpm)

TYPE: **VODL 34/TR.S.p7** CODE: 155041102

DESCRIPTION: Aluminium body, G3/4 ports, pilot ratio 1:7, range 50-350 bar (725-5075 psi), std setting 280 bar (4060 psi) @ 5 l/min (1.32 US gpm)

TYPE: **VODL 100/TR.S.p7** CODE: 1550051102

DESCRIPTION: Aluminium body, G1" ports, pilot ratio 1:7, range 50-350 bar (725-5075 psi), std setting 280 bar (4060 psi) @ 5 l/min (1.32 US gpm)

For other configurations, SAE thread and steel body, please contact our Sales Dept.

Rating diagrams

VODL 38 pressure drop vs. flow from D1->U1 and U1->D1

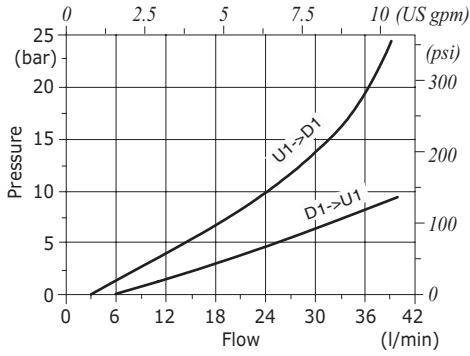

VODL 12 pressure drop vs. flow from D1->U1 and U1->D1

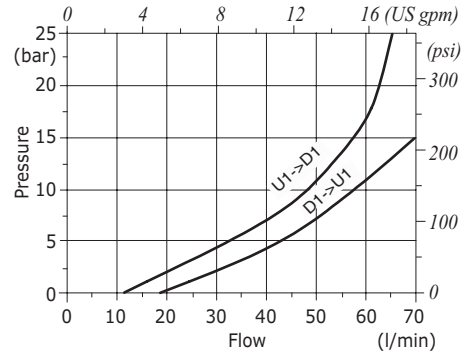

VODL 34 pressure drop vs. flow from D1->U1 and U1->D1

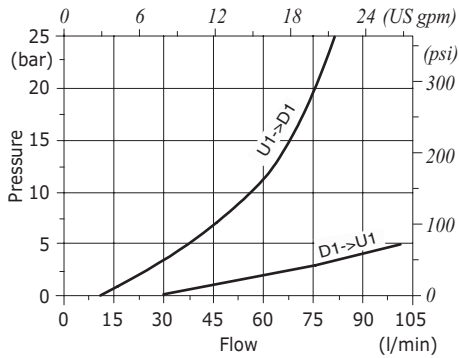

VODL 100 pressure drop vs. flow from D1->U1 and U1->D1

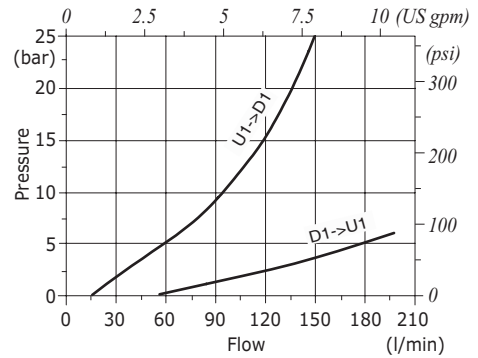

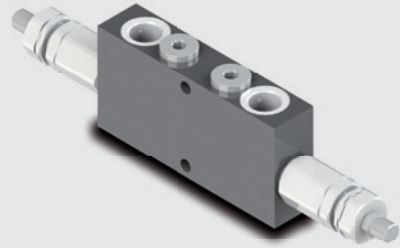

Type VODL/CC counterbalance valves

- Double acting
- Relief compensated

Technical specifications and diagrams are measured with mineral oil of 46 cSt viscosity at 40°C (104°F) temperature.

	VODL/CC 38	VODL/CC 12	VODL/CC 34	VODL/CC 100	
Nominal flow	35 l/min (9.2 US gpm)	70 l/min (18.5 US gpm)	100 l/min (26.4 US gpm)	180 l/min (47.6 US gpm)	
Max. pressure	Aluminium body = 210 bar (3050 psi) Steel body = 350 bar (5100 psi)				
Oil leakage	0.25 cm ³ /min - 0.015 in ³ /min. (5 drops) at 210 bar - 3050 psi at 80% of pressure setting				
Fluid	mineral based oil				
Viscosity	from 10 to 200 cSt				
Max. level of contamination	18/16/13 ISO4406				
Fluid temperature	with NBR seals from -20°C (-4°F) to 80°C (176°F)				
Environmental temp. for working conditions	from -40°C (-40°F) to 100°C (212°F)				
Weight	aluminium	1.45 kg (3.20 lb)	2.00 kg (4.41 lb)	3.08 kg (6.79 lb)	4.91 kg (10.82 lb)
	steel	2.62 kg (5.78 lb)	3.26 kg (7.19 lb)	5.29 kg (11.66 lb)	9.76 kg (21.52 lb)

NOTE - For different conditions, please contact Walvoil Sales Dpt.

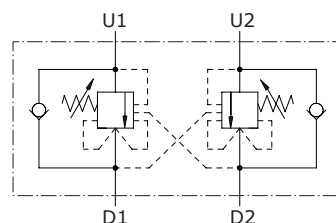

Dimensions

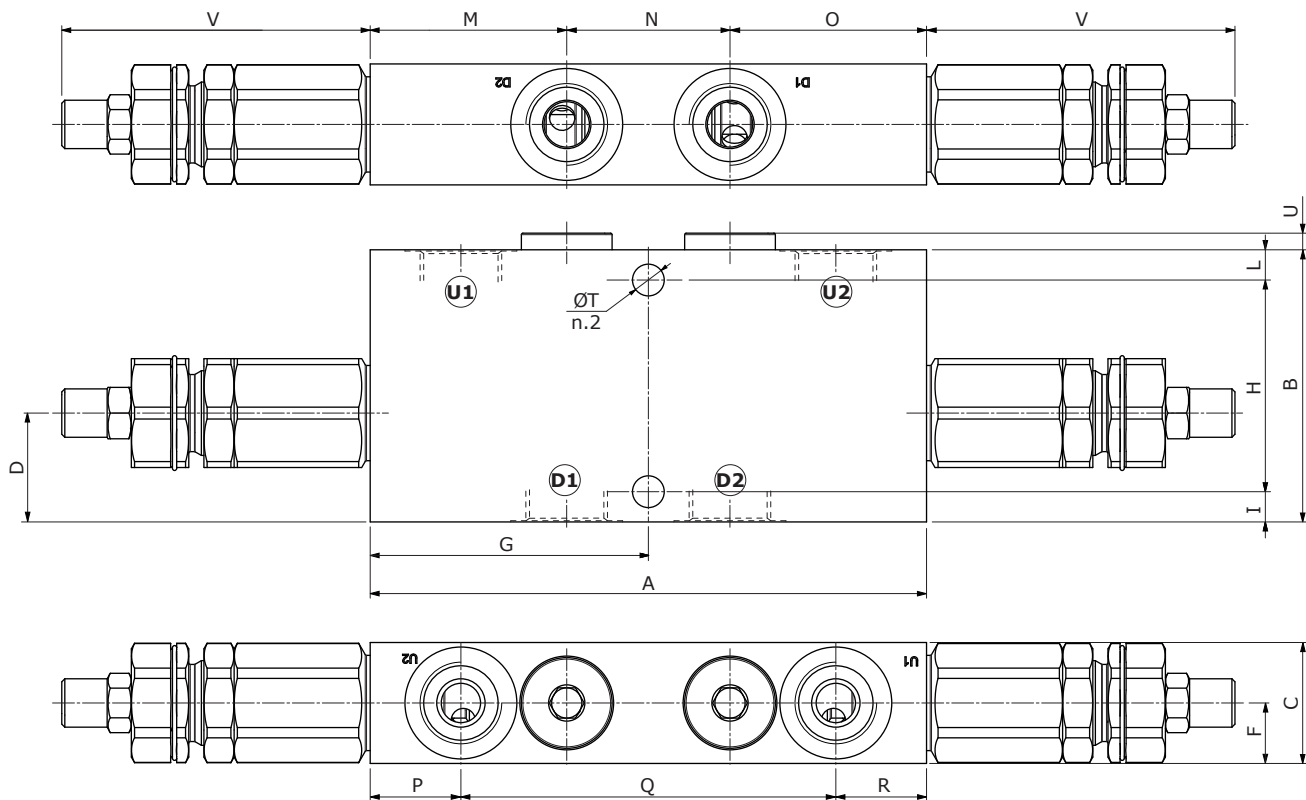

Dimensions are in mm-in

Valve type	A	B	C	F	G	H	I	L	M	N	O	P	Q	R	ØT	U	V	D1	D2	U1	U2
VODL 38/CC	141 5.55	65 2.56	30 1.18	15 0.59	70.5 2.76	40 1.57	8 0.315	17 0.67	51 2.01	39 1.54	51 2.01	22 0.87	97 3.82	22 0.87	8.5 0.335	4.5 0.177	92.5 3.64	G3/8		G3/8	
VODL 12/CC	149 5.87	70 2.76	34.5 1.36	17.25 0.68	74.5 2.93	48 1.89	8 0.315	14 0.551	50.5 1.99	48 1.89	50.5 1.99	21.5 0.85	106 4.17	21.5 0.85	8.5 0.335	4.5 0.177	100.5 1.99	G1/2		G1/2	
VODL 34/CC	184 7.25	90 3.54	40 1.57	20 0.79	92 3.62	70 2.76	10 0.394	10 0.394	65 2.56	54 2.13	65 2.56	30 1.18	124 4.88	30 1.18	10.5 0.413	5.5 0.217	102 4.02	G3/4		G3/4	
VODL 100/CC	218 8.58	100 3.94	60 2.36	30 1.18	109 4.29	80 3.15	10 0.394	10 0.394	76 2.99	66 2.60	76 2.99	30 1.18	158 6.22	30 1.18	10.5 0.413	12.5 0.492	101 3.98	G1"		G1"	

Ordering codes and description

VODL/CC complete valves

TYPE: **VODL/CC 38/TR.S.p4** CODE: 1559421100
 DESCRIPTION: Aluminium body, G3/8 ports, pilot ratio 1:4, range 50-350 bar (725-5075 psi), std setting 280 bar (4060 psi) @ 5 l/min (1.32 US gpm)

TYPE: **VODL/CC 12/TR.S.p7** CODE: 1559431100
 DESCRIPTION: Aluminium body, G1/2 ports, pilot ratio 1:7, range 50-350 bar (725-5075 psi), std setting 280 bar (4060 psi) @ 5 l/min (1.32 US gpm)

TYPE: **VODL/CC 34/TR.S.p7** CODE: 1559441100
 DESCRIPTION: Aluminium body, G3/4 ports, pilot ratio 1:7, range 50-350 bar (725-5075 psi), std setting 280 bar (4060 psi) @ 5 l/min (1.32 US gpm)

TYPE: **VODL/CC 100/TR.S.p7** CODE: 1559451100
 DESCRIPTION: Aluminium body, G1" ports, pilot ratio 1:7, range 50-350 bar (725-5075 psi), std setting 280 bar (4060 psi) @ 5 l/min (1.32 US gpm)

For other configurations and steel body, please contact our Sales Dept.

Rating diagrams

VODL/CC 38 pressure drop vs. flow from D1->U1 and U1->D1

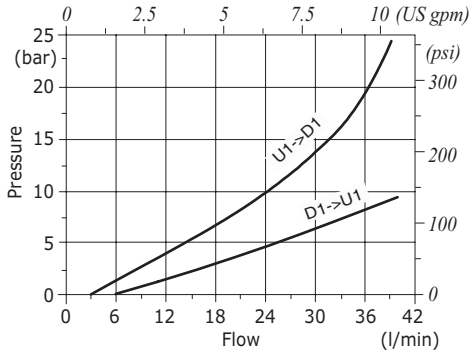

VODL/CC 12 pressure drop vs. flow from D1->U1 and U1->D1

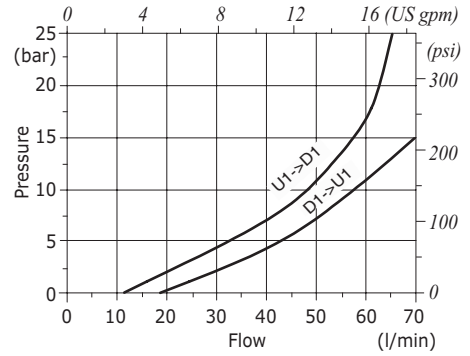

VODL/CC 34 pressure drop vs. flow from D1->U1 and U1->D1

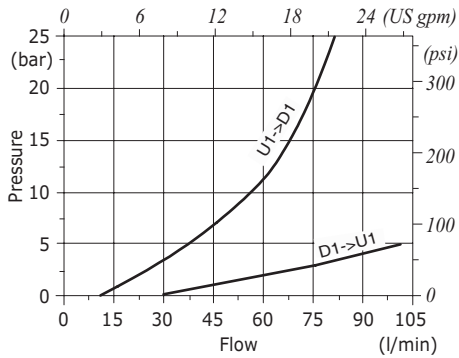

VODL/CC 100 pressure drop vs. flow from D1->U1 and U1->D1

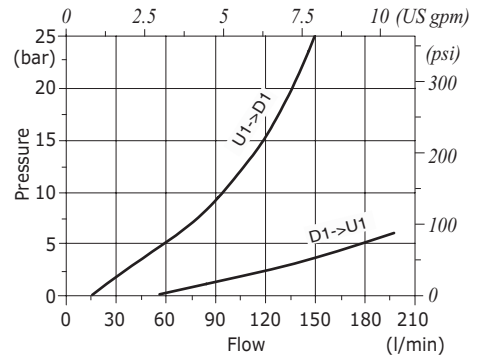



Type VODL/SC counterbalance valves

- Double acting
- Load sensitive

Technical specifications and diagrams are measured with mineral oil of 46 cSt viscosity at 40°C (104°F) temperature.

	VODL/SC 38	VODL/SC 12	VODL/SC 34	VODL/SC 100	
Nominal flow	40 l/min (10.6 US gpm)	75 l/min (19.8 US gpm)	120 l/min (31.7 US gpm)	180 l/min (47.6 US gpm)	
Max. pressure	Aluminium body = 210 bar (3050 psi) Steel body = 350 bar (5100 psi)				
Oil leakage	0.25 cm ³ /min - 0.015 in ³ /min. (5 drops) at 210 bar - 3050 psi at 80% of pressure setting				
Fluid	mineral based oil				
Viscosity	from 10 to 200 cSt				
Max. level of contamination	18/16/13 ISO4406				
Fluid temperature	with NBR seals from -20°C (-4°F) to 80°C (176°F)				
Environmental temp. for working conditions	from -40°C (-40°F) to 100°C (212°F)				
Weight	<i>aluminium</i>	1.09 kg (2.40 lb)	1.53 kg (3.37 lb)	2.26 kg (4.98 lb)	4.24 kg (9.35 lb)
	<i>steel</i>	2.15 kg (4.74 lb)	2.96 kg (6.53 lb)	4.78 kg (10.54 lb)	9.71 kg (21.41 lb)

NOTE - For different conditions, please contact Walvoil Sales Dpt.

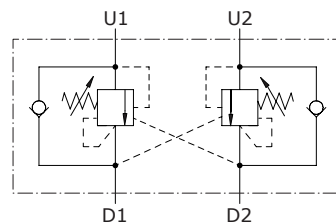

Dimensions

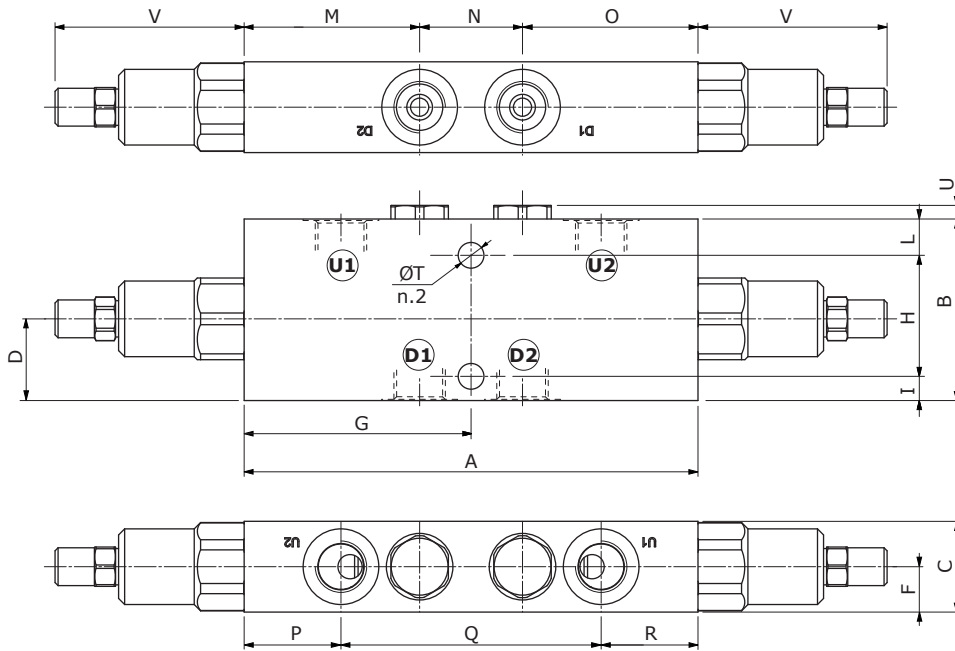

Valve type	D1	D2	U1	U2
VODL 38	G3/8	G3/8		
VODL 12	G1/2	G1/2		
VODL 34	G3/4	G3/4		
VODL 100	G1"	G1"		

Dimensions are in mm-in

Valve type	A	B	C	F	G	H	I	L	M	N	O	P	Q	R	ØT	U	V
VODL 38	150	60	30	15	75	40	8	12	58	34	58	32	86	32	8.5	4.5	62.5
	5.91	2.36	1.18	0.59	2.95	1.57	0.315	0.472	2.28	1.34	2.28	1.26	3.82	1.26	0.335	0.177	2.46
VODL 12	156	70	35	17.5	78	48	8	14	60	36	60	32	92	32	8.5	4.5	57.5
	6.14	2.76	1.38	0.69	3.07	1.89	0.315	0.551	2.52	1.89	2.52	1.26	3.62	1.26	0.335	0.177	2.26
VODL 34	186	90	40	20	93	70	10	10	68	50	68	34	118	34	10.5	5.5	63.5
	7.32	3.54	1.57	0.79	3.66	2.76	0.394	0.394	2.68	1.97	2.68	2.28	4.65	2.28	0.413	0.217	2.50
VODL 100	232	100	60	30	116	80	10	10	83	66	83	35	162	35	10.5	12.5	63.5
	9.13	3.94	2.36	1.18	4.57	3.15	0.394	0.394	3.27	2.60	3.27	1.38	6.38	1.38	0.413	0.492	2.50

Ordering codes and description

VODL/SC complete valves

TYPE: **VODL/SC 38/TR.S.p4** CODE: 1560021102
 DESCRIPTION: Aluminium body, G3/8 ports, pilot ratio 1:4, range 50-350 bar (725-5075 psi), std setting 280 bar (4060 psi) @ 5 l/min (1.32 US gpm)

TYPE: **VODL/SC 12/TR.S.p7** CODE: 1560031102
 DESCRIPTION: Aluminium body, G1/2 ports, pilot ratio 1:7, range 50-350 bar (725-5075 psi), std setting 280 bar (4060 psi) @ 5 l/min (1.32 US gpm)

TYPE: **VODL/SC 34/TR.S.p7** CODE: 1560041102
 DESCRIPTION: Aluminium body, G3/4 ports, pilot ratio 1:7, range 50-350 bar (725-5075 psi), std setting 280 bar (4060 psi) @ 5 l/min (1.32 US gpm)

TYPE: **VODL/SC 100/TR.S.p7** CODE: 1560051102
 DESCRIPTION: Aluminium body, G1" ports, pilot ratio 1:7, range 50-350 bar (725-5075 psi), std setting 280 bar (4060 psi) @ 5 l/min (1.32 US gpm)

For other configurations and steel body, please contact our Sales Dept.

Rating diagrams

VODL/SC 38 pressure drop vs. flow from D1->U1 and U1->D1

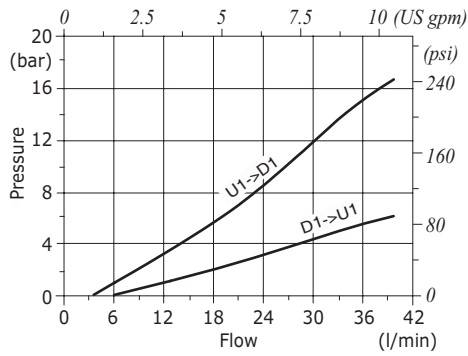

VODL/SC 12 pressure drop vs. flow from D1->U1 and U1->D1

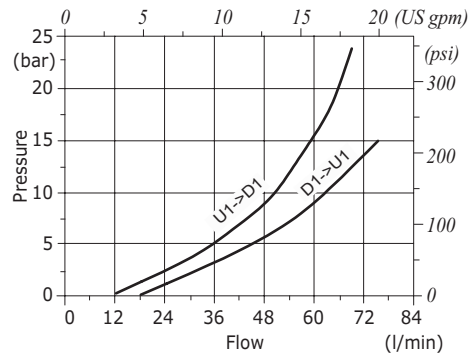

VODL/SC 34 pressure drop vs. flow from D1->U1 and U1->D1

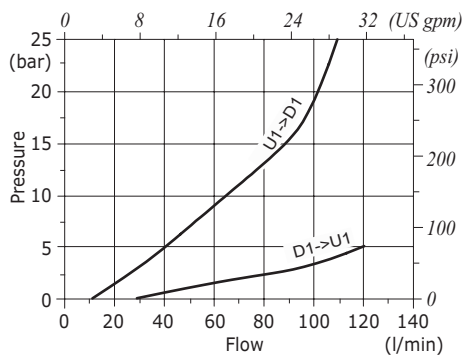

VODL/SC 100 pressure drop vs. flow from D1->U1 and U1->D1

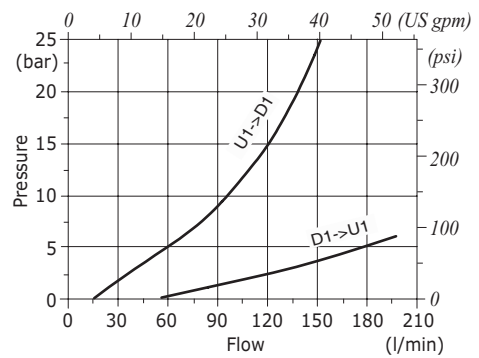

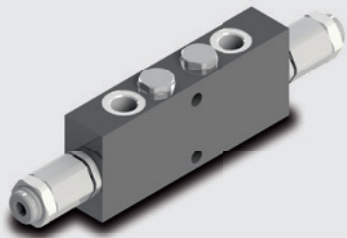

Type VODL/SC/CC counterbalance valves

- Double acting
- Relief compensated

Technical specifications and diagrams are measured with mineral oil of 46 cSt viscosity at 40°C (104°F) temperature.

	VODL/SC/CC 38	VODL/SC/CC 12	VODL/SC/CC 34	VODL/SC/CC 100	
Nominal flow	40 l/min (10.6 US gpm)	75 l/min (18.5 US gpm)	120 l/min (31.7 US gpm)	180 l/min (47.6 US gpm)	
Max. pressure	Aluminium body = 210 bar (3050 psi) Steel body = 350 bar (5100 psi)				
Oil leakage	0.25 cm ³ /min - 0.015 in ³ /min. (5 drops) at 210 bar - 3050 psi at 80% of pressure setting				
Fluid	mineral based oil				
Viscosity	from 10 to 200 cSt				
Max. level of contamination	18/16/13 ISO4406				
Fluid temperature	with NBR seals from -20°C (-4°F) to 80°C (176°F)				
Environmental temp. for working conditions	from -40°C (-40°F) to 100°C (212°F)				
Weight	aluminium	1.14 kg (2.51 lb)	1.63 kg (3.59 lb)	2.37 kg (5.22 lb)	4.35 kg (9.59 lb)
	steel	2.18 kg (4.81 lb)	3.06 kg (6.75 lb)	4.85 kg (10.69 lb)	9.82 kg (21.65 lb)

NOTE - For different conditions, please contact Walvoil Sales Dpt.

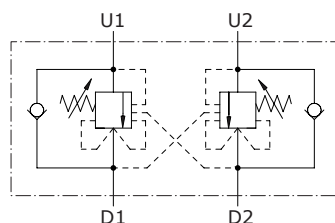

Dimensions

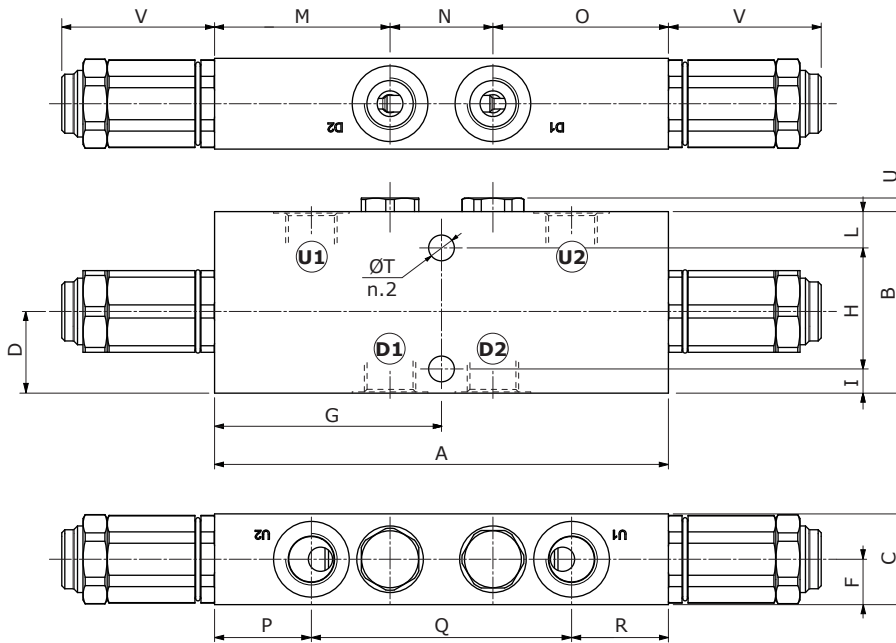

Valve type	D1	D2	U1	U2
VODL 38	G3/8	G3/8		
VODL 12	G1/2	G1/2		
VODL 34	G3/4	G3/4		
VODL 100	G1"	G1"		

Dimensions are in mm-in

Valve type	A	B	C	F	G	H	I	L	M	N	O	P	Q	R	ØT	U	V
VODL 38	150	60	30	15	75	40	8	12	58	34	58	32	86	32	8.5	4.5	50.5
	5.91	2.36	1.18	0.59	2.95	1.57	0.315	0.472	2.28	1.34	2.28	1.26	3.82	1.26	0.335	0.177	1.99
VODL 12	156	70	35	17.5	78	48	8	14	60	36	60	32	92	32	8.5	4.5	50.5
	6.14	2.76	1.38	0.69	3.07	1.89	0.315	0.551	2.52	1.89	2.52	1.26	3.62	1.26	0.335	0.177	1.99
VODL 34	186	90	40	20	93	70	10	10	68	50	68	34	118	34	10.5	5.5	50.5
	7.32	3.54	1.57	0.79	3.66	2.76	0.394	0.394	2.68	1.97	2.68	2.28	4.65	2.28	0.413	0.217	1.99
VODL 100	232	100	60	30	116	80	10	10	83	66	83	35	162	35	10.5	12.5	50.5
	9.13	3.94	2.36	1.18	4.57	3.15	0.394	0.394	3.27	2.60	3.27	1.38	6.38	1.38	0.413	0.492	1.99

Ordering codes and description

VODL/SC/CC complete valves

TYPE: **VODL/SC/CC 38/TR.S.p4** CODE: 1565021102
 DESCRIPTION: Aluminium body, G3/8 ports, pilot ratio 1:4, range 50-350 bar (725-5075 psi), std setting 280 bar (4060 psi) @ 5 l/min (1.32 US gpm)

TYPE: **VODL/SC/CC 12/TR.S.p7** CODE: 1565031102
 DESCRIPTION: Aluminium body, G1/2 ports, pilot ratio 1:7, range 50-350 bar (725-5075 psi), std setting 280 bar (4060 psi) @ 5 l/min (1.32 US gpm)

TYPE: **VODL/SC/CC 34/TR.S.p7** CODE: 1565041102
 DESCRIPTION: Aluminium body, G3/4 ports, pilot ratio 1:7, range 50-350 bar (725-5075 psi), std setting 280 bar (4060 psi) @ 5 l/min (1.32 US gpm)

TYPE: **VODL/SC/CC 100/TR.S.p7** CODE: 1565051102
 DESCRIPTION: Aluminium body, G1" ports, pilot ratio 1:7, range 50-350 bar (725-5075 psi), std setting 280 bar (4060 psi) @ 5 l/min (1.32 US gpm)

For other configurations and steel body, please contact our Sales Dept.

VODL/SC/CC 38 pressure drop vs. flow from D1->U1 and U1->D1

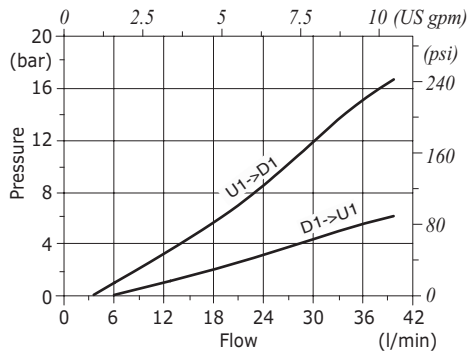

VODL/SC/CC 12 pressure drop vs. flow from D1->U1 and U1->D1

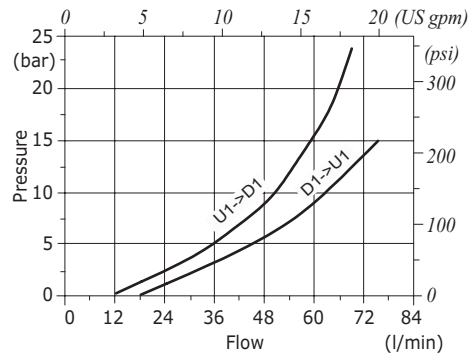

VODL/SC/CC 34 pressure drop vs. flow from D1->U1 and U1->D1

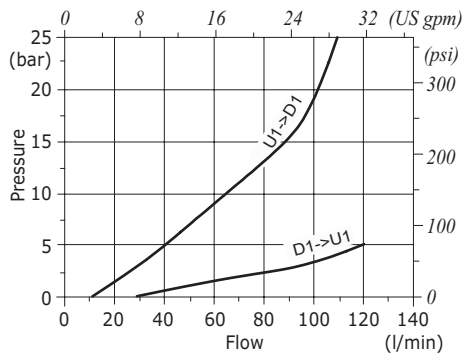

VODL/SC/CC 100 pressure drop vs. flow from D1->U1 and U1->D1

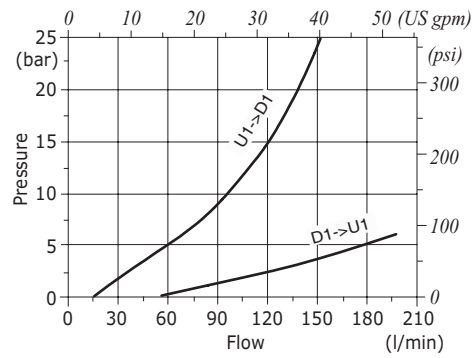



Type VODL/ML counterbalance valves

- Double acting
- Load sensitive
- Flange assembling according to ISO 4401:2005 (CETOP)

Technical specifications and diagrams are measured with mineral oil of 46 cSt viscosity at 40°C (104°F) temperature.

	VODL/ML 6-38	VODL/ML 10-12	
Nominal flow	35 l/min (9.2 US gpm)	70 l/min (18.5 US gpm)	
Max. pressure	Aluminium body = 210 bar (3050 psi) Steel body = 350 bar (5100 psi)		
Oil leakage	0.25 cm ³ /min - 0.015 in ³ /min. (5 drops) at 210 bar - 3050 psi at 80% of pressure setting		
Fluid	mineral based oil		
Viscosity	from 10 to 200 cSt		
Max. level of contamination	18/16/13 ISO4406		
Fluid temperature	with NBR seals from -20°C (-4°F) to 80°C (176°F)		
Environmental temp. for working conditions	from -40°C (-40°F) to 100°C (212°F)		
Weight	aluminium	1.75 kg (3.86 lb)	3.25 kg (7.147 lb)
	steel	3.70 kg (8.16 lb)	7.55 kg (16.64 lb)

NOTE - For different conditions, please contact Walvoil Sales Dpt.

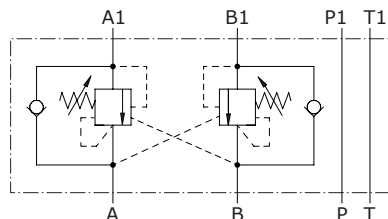

Dimensions

VODL/ML 6-38

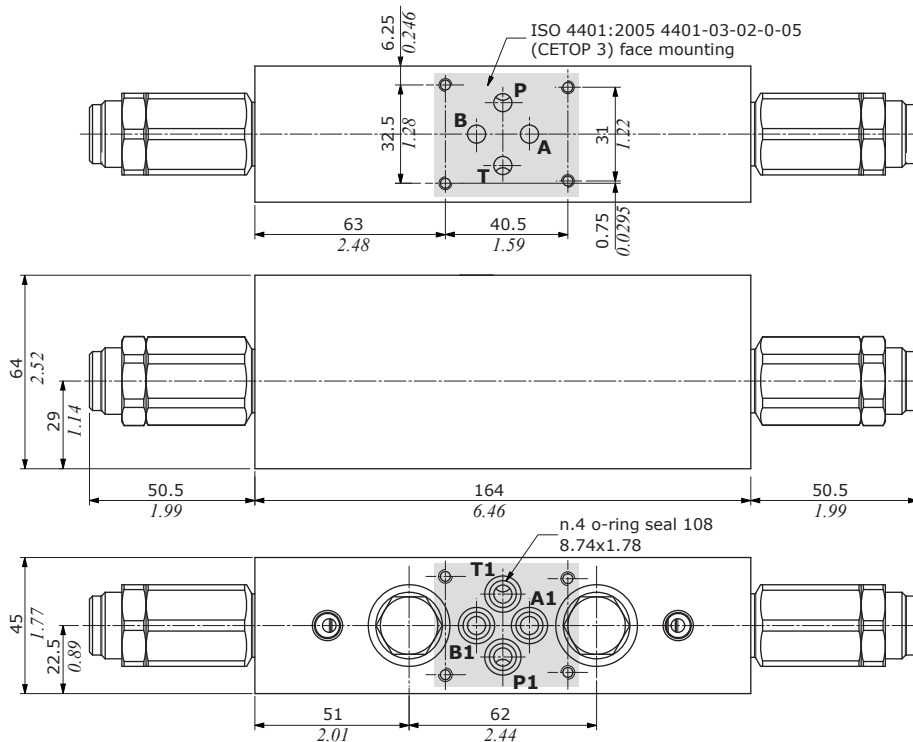

VODL/ML 10-12

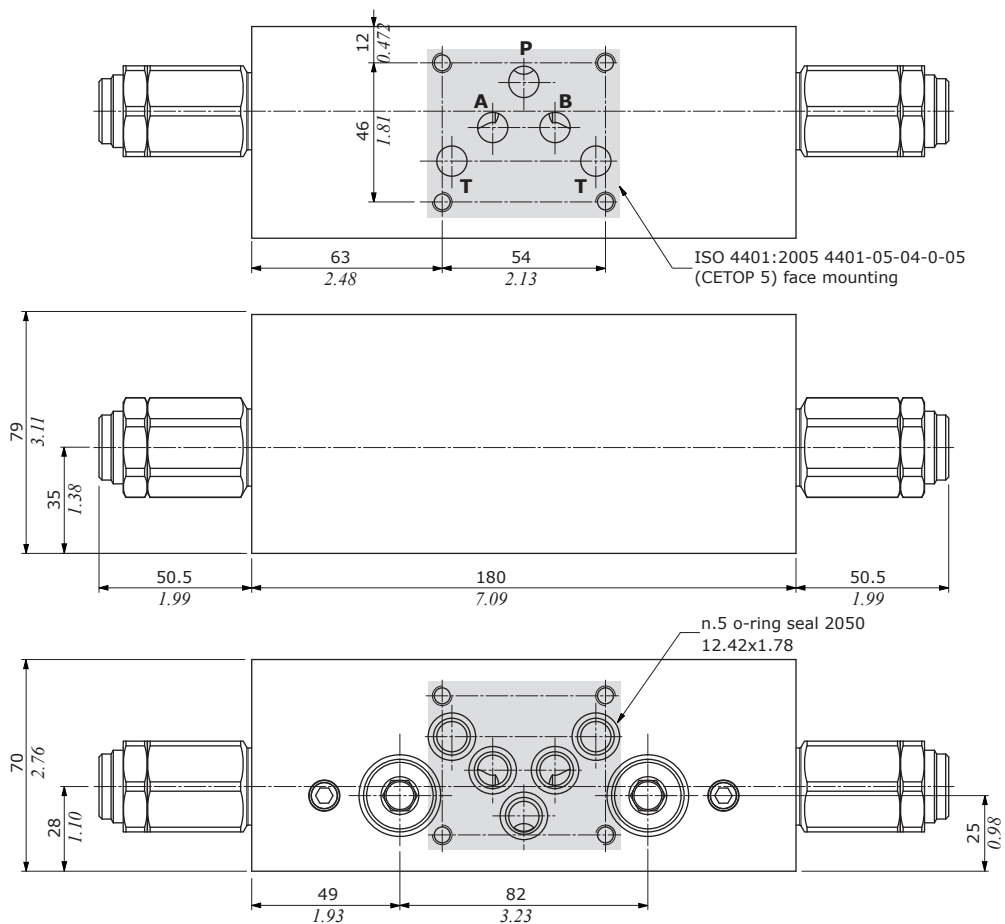

VODL/ML complete valves

TYPE: **VODL/ML 6-38/TR.S.p4** CODE: 1558021802
 DESCRIPTION: Aluminium body, CETOP 3 flange, pilot ratio 1:4, range 50-350 bar (725-5075 psi), std setting 280 bar (4060 psi) @ 5 l/min (1.32 US gpm)
 TYPE: **VODL/ML 10-12/TR.S.p7** CODE: 1518031802
 DESCRIPTION: Aluminium body, CETOP 5 flange, pilot ratio 1:7, range 50-350 bar (725-5075 psi), std setting 280 bar (4060 psi) @ 5 l/min (1.32 US gpm)
 For other configurations and steel body, please contact our Sales Dept.

Rating diagrams

VODL/ML 6-38 pressure drop vs. flow from A->A1 (B->B1) and A1->A (B1->B)

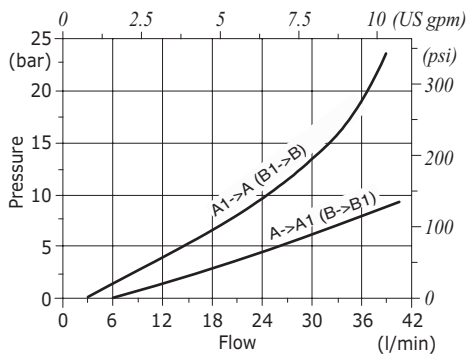

VODL/ML 10-12 pressure drop vs. flow from A->A1 (B->B1) and A1->A (B1->B)

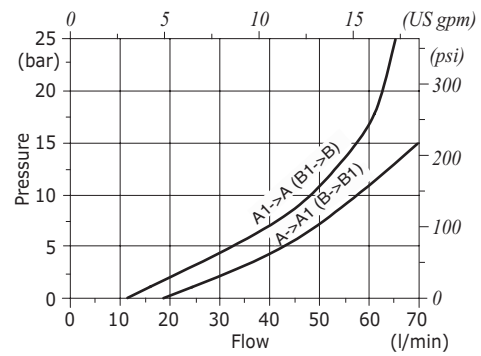



Type VABAL counterbalance valves

- Cross line, relief valve for motion control
- Load sensitive

Technical specifications and diagrams are measured with mineral oil of 46 cSt viscosity at 40°C (104°F) temperature.

	VABAL 38	VABAL 12	VABAL 34	VABAL 100	
Nominal flow	35 l/min (9.2 US gpm)	70 l/min (18.5 US gpm)	100 l/min (26.4 US gpm)	180 l/min (47.5 US gpm)	
Max. pressure	Aluminium body = 210 bar (3050 psi) Steel body = 350 bar (5100 psi)				
Oil leakage	0.25 cm ³ /min - 0.015 in ³ /min. (5 drops) at 210 bar - 3050 psi at 80% of pressure setting				
Fluid	mineral based oil				
Viscosity	from 10 to 200 cSt				
Max. level of contamination	18/16/13 ISO4406				
Fluid temperature	with NBR seals from -20°C (-4°F) to 80°C (176°F)				
Environmental temp. for working conditions	from -40°C (-40°F) to 100°C (212°F)				
Weight	aluminium	2.16 kg (4.76 lb)	2.48 kg (5.47 lb)	4.47 kg (9.85 lb)	9.32 kg (20.55 lb)
	steel	4.33 kg (9.55 lb)	5.14 kg (11.33 lb)	9.05 kg (19.95 lb)	20.65 kg (45.53 lb)

NOTE - For different conditions, please contact Walvoil Sales Dpt.

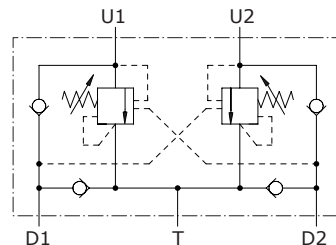

Dimensions

Valve type	D1 D2	U1 U2	T
VABAL 38	G3/8	G3/8	G3/8
VABAL 12	G1/2	G1/2	G1/2
VABAL 34	G3/4	G3/4	G3/4
VABAL 100	G1"	G1"	G1"

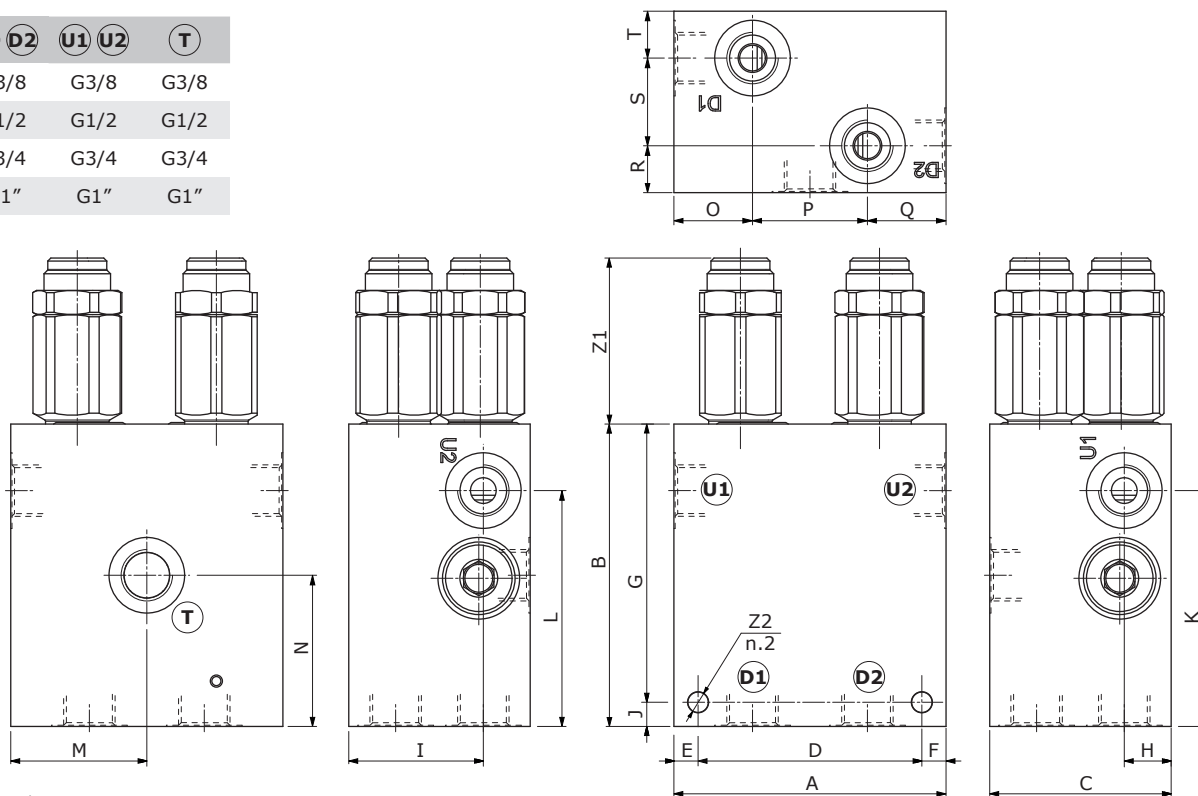

Dimensions are in mm-in

Valve type	A	B	C	D	E	F	G	J	K
VODL 38	90	100	60	74	8	8	92	8	78
	3.54	3.94	2.36	2.91	0.315	0.315	3.62	0.315	3.07
VODL 12	100	100	70	84	8	8	92	8	78.5
	3.94	3.94	2.76	3.31	0.315	0.315	3.62	0.315	3.09
VODL 34	120	120	85	100	10	10	110	10	90
	4.72	4.72	3.35	3.94	0.394	0.394	4.33	0.394	3.54
VODL 100	160	160	110	136	12	12	148	12	130
	6.30	6.30	4.33	5.35	0.472	0.472	5.83	0.472	5.12

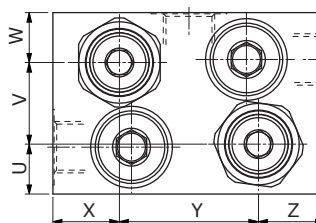

Valve type	H	I	L	M	N	O	P	Q	R	S	T	U	V	W	X	Y	Z	Z1	Z2
VODL 38	15.5	44.5	78	45	50	26	38	26	15.5	29	15.5	16.5	27	16.5	22	46	22	54.8	M8
	0.61	1.75	3.07	1.77	1.97	1.02	1.50	1.02	0.61	1.14	0.61	0.65	1.06	0.65	0.87	1.81	0.87	2.16	
VODL 12	17.5	52.5	78.5	50	48	29	42	29	17.5	35	17.5	18.5	33	18.5	27	46	27	50.2	M8
	0.69	2.07	3.09	1.97	1.89	1.14	1.14	1.14	0.69	1.38	0.69	0.73	1.30	0.73	1.06	1.81	1.06	1.98	
VODL 34	21	64	90	60	55	33	54	33	21	43	21	24	37	24	28	64	28	60.8	M10
	0.83	2.52	3.54	2.36	2.17	1.30	2.13	1.30	0.83	1.70	0.83	0.94	1.46	0.94	1.10	2.52	1.10	2.39	
VODL 100	30	80	130	80	84	47	66	47	30	50	30	30	50	30	47	66	47	64.7	M12
	1.18	3.15	5.12	3.15	3.31	1.85	2.60	1.85	1.18	1.97	1.18	1.18	1.97	1.18	1.85	2.60	1.85	2.54	

Ordering codes

VABAL complete valves

TYPE: **VABAL 38/TR.S.p4** CODE: 1570021102
 DESCRIPTION: Aluminium body, G3/8 ports, pilot ratio 1:4, range 50-350 bar (725-5075 psi), std setting 280 bar (4060 psi) @ 5 l/min (1.32 US gpm)

TYPE: **VABAL 12/TR.S.p7** CODE: 1570031102
 DESCRIPTION: Aluminium body, G1/2 ports, pilot ratio 1:7, range 50-350 bar (725-5075 psi), std setting 280 bar (4060 psi) @ 5 l/min (1.32 US gpm)

TYPE: **VABAL 34/TR.S.p7** CODE: 1570041102
 DESCRIPTION: Aluminium body, G3/4 ports, pilot ratio 1:7, range 50-350 bar (725-5075 psi), std setting 280 bar (4060 psi) @ 5 l/min (1.32 US gpm)

TYPE: **VABAL 100/TR.S.p7.PG** CODE: 1570051102
 DESCRIPTION: Aluminium body, G1" ports, pilot ratio 1:7, range 50-350 bar (725-5075 psi), std setting 280 bar (4060 psi) @ 5 l/min (1.32 US gpm)

For other configurations and steel body, please contact our Sales Dept.

Rating diagrams

VABAL 38 pressure drop vs. flow from U1->D1 (U2->D2) and D1->U1 (D2->U2)

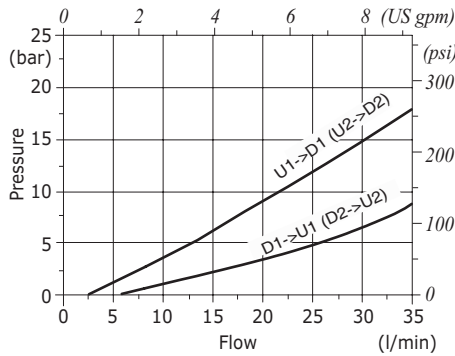

VABAL 38 pressure setting vs. flow from U1 (U2)->T

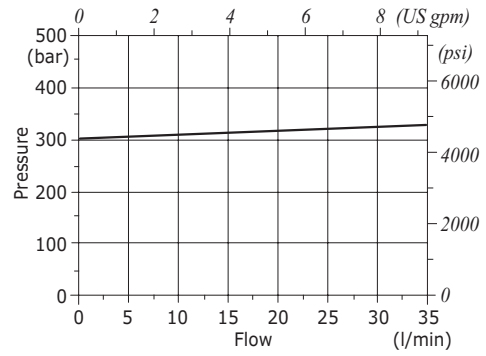

VABAL 12 pressure drop vs. flow from U1->D1 (U2->D2) and D1->U1 (D2->U2)

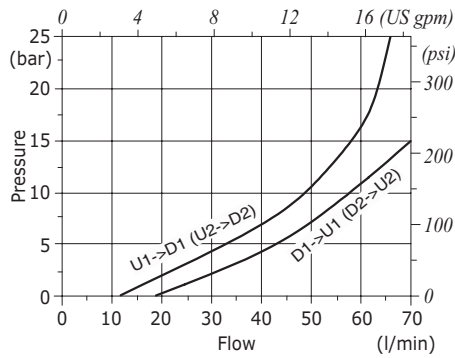

VABAL 12 pressure setting vs. flow from U1 (U2)->T

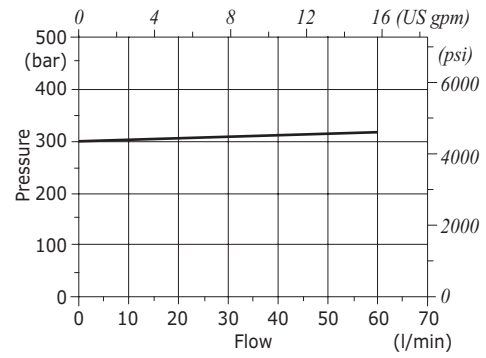

VABAL 34 pressure drop vs. flow from U1->D1 (U2->D2) and D1->U1 (D2->U2)

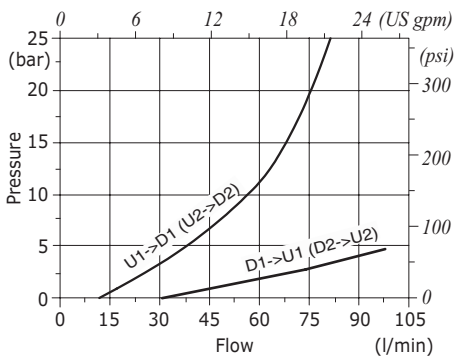

VABAL 34 pressure setting vs. flow from U1 (U2)->T

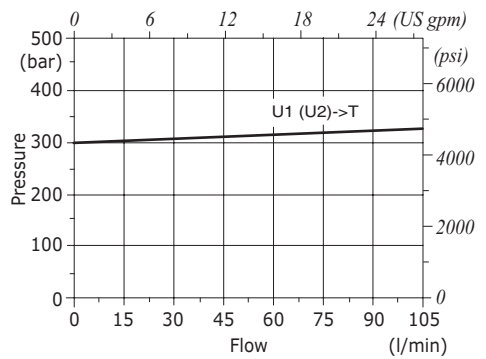

VABAL 100 pressure drop vs. flow from U1->D1 and D1->U1

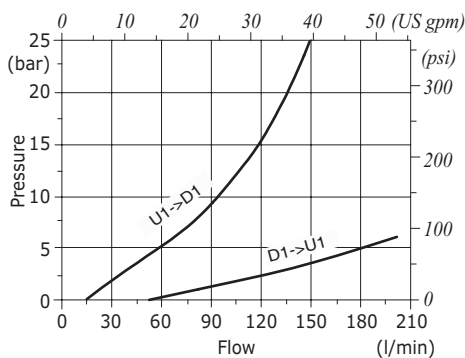



Type VABAL/SF counterbalance valves

- Cross line, relief valve for motion control
- Load sensitive

Technical specifications and diagrams are measured with mineral oil of 46 cSt viscosity at 40°C (104°F) temperature.

	VABAL/SF 38	VABAL/SF 12	VABAL/SF 34	VABAL/SF 100	
Nominal flow	35 l/min (9.2 US gpm)	70 l/min (18.5 US gpm)	100 l/min (26.4 US gpm)	180 l/min (47.6 US gpm)	
Max. pressure	Aluminium body = 210 bar (3050 psi) Steel body = 350 bar (5100 psi)				
Oil leakage	0.25 cm ³ /min - 0.015 in ³ /min. (5 drops) at 210 bar - 3050 psi at 80% of pressure setting				
Fluid	mineral based oil				
Viscosity	from 10 to 200 cSt				
Max. level of contamination	18/16/13 ISO4406				
Fluid temperature	with NBR seals from -20°C (-4°F) to 80°C (176°F)				
Environmental temp. for working conditions	from -40°C (-40°F) to 100°C (212°F)				
Weight	aluminium	2.73 kg (6.02 lb)	2.50 kg (5.51 lb)	4.52 kg (9.96 lb)	9.27 kg (20.44 lb)
	steel	4.31 kg (9.50 lb)	5.19 kg (11.44 lb)	9.03 kg (19.91 lb)	20.27 kg (44.69 lb)

NOTE - For different conditions, please contact Walvoil Sales Dpt.

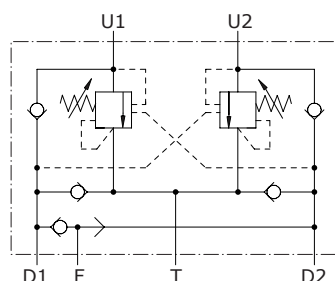

Dimensions

Valve type	D1	D2	U1	U2	T	F
VABAL 38	G3/8	G3/8	G3/8	G3/8	G1/4	G1/4
VABAL 12	G1/2	G1/2	G1/2	G1/2	G1/2	G1/4
VABAL 34	G3/4	G3/4	G3/4	G3/4	G3/4	G1/4
VABAL 100	G1"	G1"	G1"	G1"	G1"	G1/4

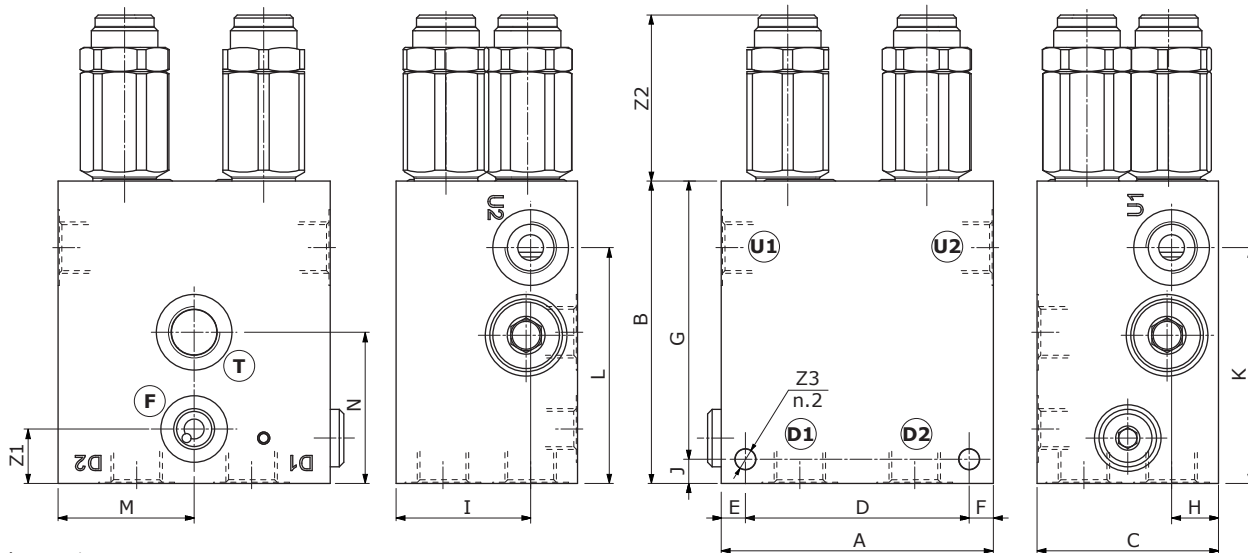
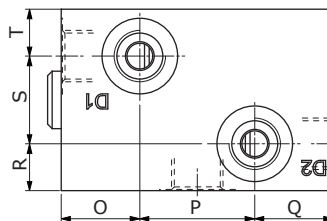

Dimensions are in mm-in

Valve type	A	B	C	D	E	F	G	J	K
VODL 38	90	100	60	74	8	8	92	8	78
	3.54	3.94	2.36	2.91	0.315	0.315	3.62	0.315	3.07
VODL 12	100	100	70	84	8	8	92	8	78.5
	3.94	3.94	2.76	3.31	0.315	0.315	3.62	0.315	3.09
VODL 34	120	120	85	100	10	10	110	10	90
	4.72	4.72	3.35	3.94	0.394	0.394	4.33	0.394	3.54
VODL 100	160	160	110	136	12	12	148	12	130
	6.30	6.30	4.33	5.35	0.472	0.472	5.83	0.472	5.12

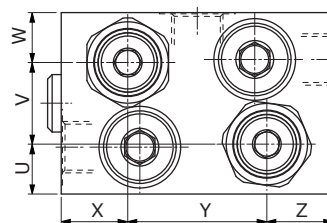

Valve type	H	I	L	M	N	O	P	Q	R	S	T	U	V	W	X	Y	Z	Z1	Z2	Z3
VODL 38	15.5	44.5	78	45	50	26	38	26	15.5	29	15.5	16.5	27	16.5	22	46	22	18	54.8	M8
	0.61	1.75	3.07	1.77	1.97	1.02	1.50	1.02	0.61	1.14	0.61	0.65	1.06	0.65	0.87	1.81	0.87	0.71	2.16	
VODL 12	17.5	52.5	78.5	50	48	29	42	29	17.5	35	17.5	18.5	33	18.5	27	46	27	18	50.2	M8
	0.69	2.07	3.09	1.97	1.89	1.14	1.14	1.14	0.69	1.38	0.69	0.73	1.30	0.73	1.06	1.81	1.06	0.71	1.98	
VODL 34	21	64	90	60	55	33	54	33	21	43	21	24	37	24	28	64	28	20	60.8	M10
	0.83	2.52	3.54	2.36	2.17	1.30	2.13	1.30	0.83	1.70	0.83	0.94	1.46	0.94	1.10	2.52	1.10	0.79	2.39	
VODL 100	30	80	130	80	84	47	66	47	30	50	30	30	50	30	47	66	47	27	64.7	M12
	1.18	3.15	5.12	3.15	3.31	1.85	2.60	1.85	1.18	1.97	1.18	1.18	1.97	1.18	1.85	2.60	1.85	1.06	2.54	

Ordering codes

VABAL/SF complete valves

TYPE: **VABAL/SF 38/TR.S.p3** CODE: 1572021103
 DESCRIPTION: Aluminium body, G3/8 ports, pilot ratio 1:3, range 50-350 bar (725-5075 psi), std setting 280 bar (4060 psi) @ 5 l/min (1.32 US gpm)

TYPE: **VABAL/SF 12/TR.S.p3** CODE: 1572031103
 DESCRIPTION: Aluminium body, G1/2 ports, pilot ratio 1:3, range 50-350 bar (725-5075 psi), std setting 280 bar (4060 psi) @ 5 l/min (1.32 US gpm)

TYPE: **VABAL/SF 34/TR.S.p3** CODE: 1572041103
 DESCRIPTION: Aluminium body, G3/4 ports, pilot ratio 1:3, range 50-350 bar (725-5075 psi), std setting 280 bar (4060 psi) @ 5 l/min (1.32 US gpm)

TYPE: **VABAL/SF 100/TR.S.p3.PG** CODE: 1572051103
 DESCRIPTION: Aluminium body, G1" ports, pilot ratio 1:3, range 50-350 bar (725-5075 psi), std setting 280 bar (4060 psi) @ 5 l/min (1.32 US gpm)

For other configurations and steel body please contact our Sales Dept.

Rating diagrams

VABAL 38 pressure drop vs. flow from U1->D1 (U2->D2) and D1->U1 (D2->U2)

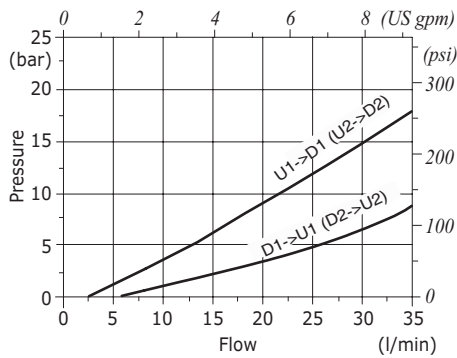

VABAL 38 pressure setting vs. flow from U1 (U2)->T

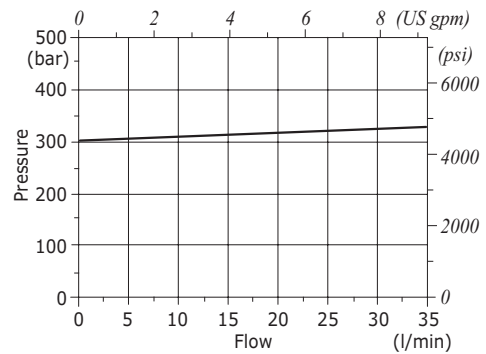

VABAL 12 pressure drop vs. flow from U1->D1 (U2->D2) and D1->U1 (D2->U2)

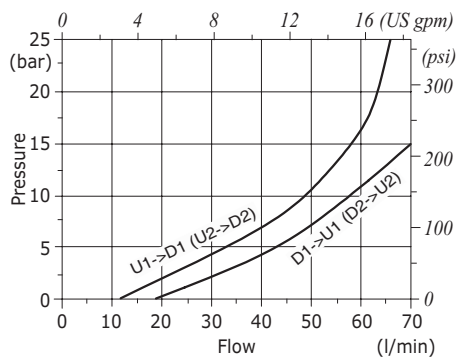

VABAL 12 pressure setting vs. flow from U1 (U2)->T

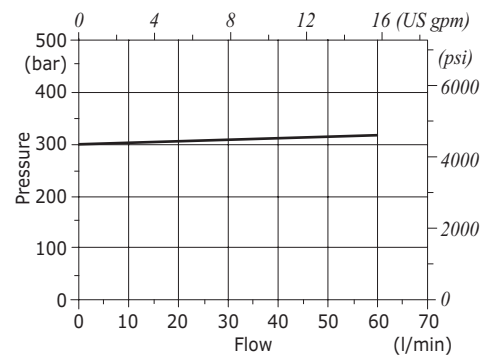

VABAL 34 pressure drop vs. flow from U1->D1 (U2->D2) and D1->U1 (D2->U2)

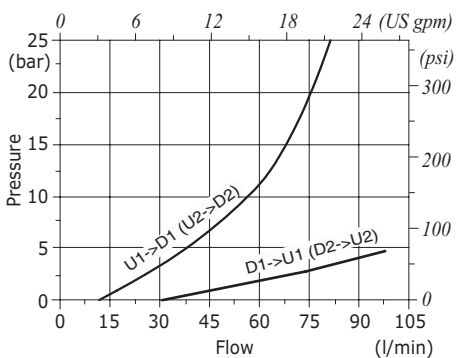

VABAL 34 pressure setting vs. flow from U1 (U2)->T

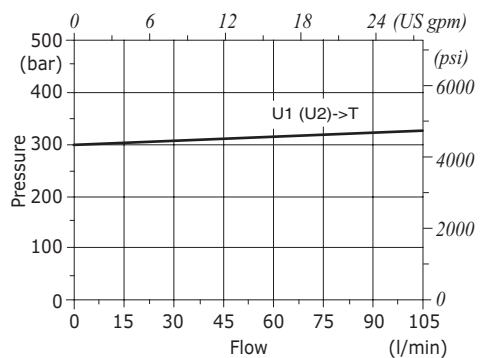

VABAL 100 pressure drop vs. flow from U1->D1 and D1->U1

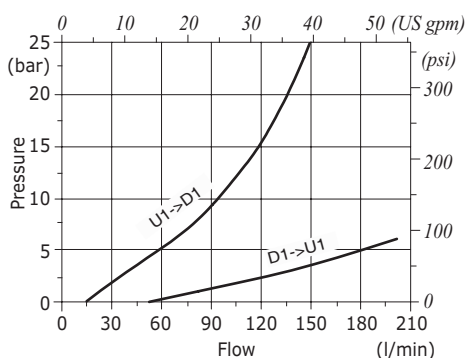



Type VSRU needle valves

- Ball type or poppet type
- With check valve

Technical specifications and diagrams are measured with mineral oil of 46 cSt viscosity at 40°C (104°F) temperature.

	VSRU..14	VSRU..38	VSRU..12	VSRU..34	VSRU..100	VSRU..114	VSRU..112	
Nominal flow from A to B	30 l/min (7.9 US gpm)	40 l/min (10.6 US gpm)	50 l/min (13.2 US gpm)	80 l/min (21.1 US gpm)	110 l/min (29 US gpm)	150 l/min (39.6 US gpm)	210 l/min (55.5 US gpm)	
Nominal flow C from B to A	30 l/min (7.9 US gpm)	50 l/min (13.2 US gpm)	80 l/min (21.1 US gpm)	110 l/min (29 US gpm)	160 l/min (42.27 US gpm)	210 l/min (55.5 US gpm)	280 l/min (74 US gpm)	
Nominal flow S from B to A	12 l/min (3.17 US gpm)	25 l/min (6.6 US gpm)	35 l/min (9.25 US gpm)	50 l/min (13.2 US gpm)	-	-	-	
Max. pressure	350 bar (5100 psi)	350 bar (5100 psi)	350 bar (5100 psi)	300 bar (4350 psi)	250 bar (3600 psi)	230 bar (3300 psi)	230 bar (3300 psi)	
Fluid	mineral based oil							
Viscosity	from 10 to 200 cSt							
Max. level of contamination	18/16/13 ISO4406							
Fluid temperature	with NBR seals: from -20°C (-4°F) to 80°C (176°F)							
Environmental temp. for working conditions	from -40°C (-40°F) to 100°C (212°F)							
Weight	steel	0.30 kg (0.66 lb)	0.48 kg (1.06 lb)	0.59 kg (1.3 lb)	1.34 kg (2.95 lb)	2.15 kg (4.74 lb)	3.31 kg (7.3 lb)	4.76 kg (10.49 lb)

NOTE - For different conditions, please contact Walvoil Sales Dpt.

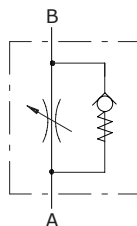

Dimensions

Dimensions are in mm-*in*

Valve type	All ports	A	⌀B	⌀c
VSRU..14	G 1/4	66-2.6	32	22
VSRU..38	G 3/8	77.5-3.05	38	26
VSRU..12	G 1/2	83-3.27	41	30
VSRU..34	G 3/4	104-4.09	55	38
VSRU..100	G 1"	118.5-4.66	65	46
VSRU..114	G 1" 1/4	135-5.31	80	55
VSRU..112	G 1" 1/2	149.5-5.88	90	62

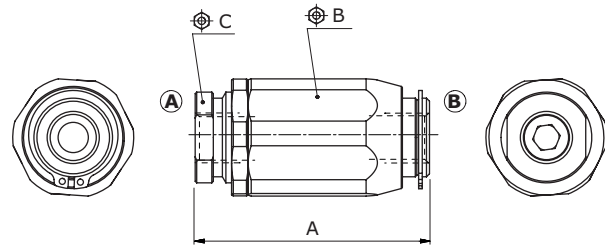

Ordering codes and description composition

Port size — Opening pressure
VSRU / C 14 Pa0,5
 — C poppet type
 — S ball type

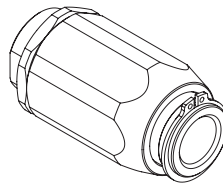

VSRU/C Complete valves

TYPE	CODE	DESCRIPTION
Poppet type, opening pressure 0.5 bar (7.25 psi)		
VSRU/C 14/Pa0,5	1603110100	Steel body, G1/4 ports
VSRU/C 38/Pa0,5	1603120100	Steel body, G3/8 ports
VSRU/C 12/Pa0,5	1603130100	Steel body, G1/2 ports
VSRU/C 34/Pa0,5	1603140100	Steel body, G3/4 ports
VSRU/C 100/Pa0,5	1603150100	Steel body, G1 ports
VSRU/C 114/Pa0,5	1603160100	Steel body, G 1" 1/4 ports
VSRU/C 112/Pa0,5	1603170100	Steel body, G 1" 1/2 ports

For different configurations or SAE thread please contact our Sales Dpt.

VSRU/S Complete valves

TYPE	CODE	DESCRIPTION
Ball type, opening pressure 4 bar (58 psi)		
VSRU/S 14/Pa4	1603010100	Steel body, G1/4 ports
VSRU/S 38/Pa4	1603020100	Steel body, G3/8 ports
VSRU/S 12/Pa4	1603030100	Steel body, G1/2 ports
VSRU/S 34/Pa4	1603040100	Steel body, G3/4 ports

Rating diagrams

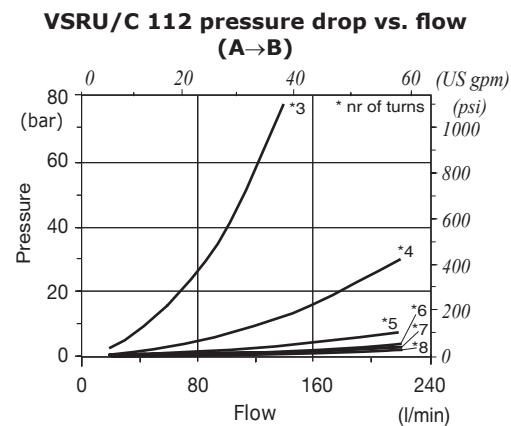
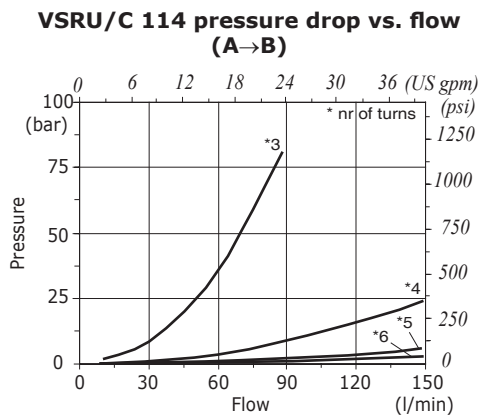
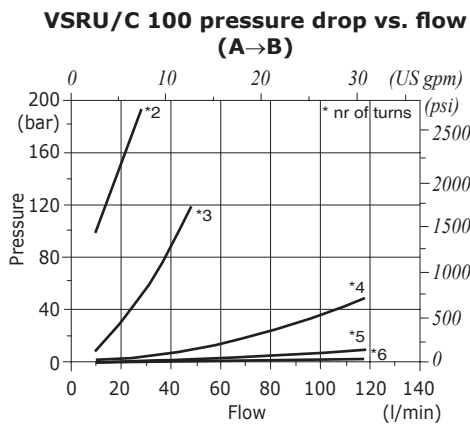
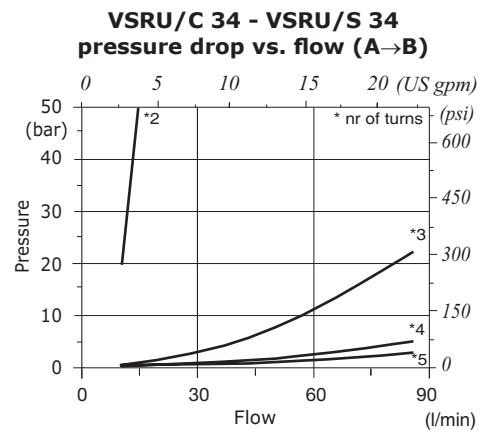
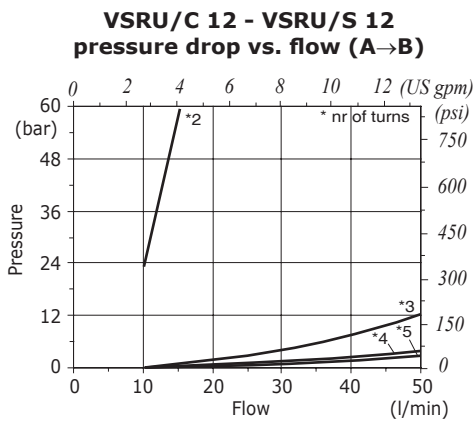
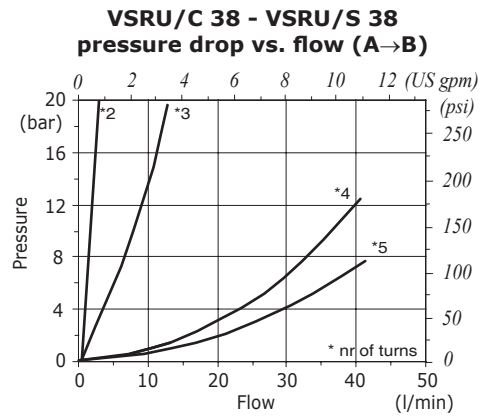
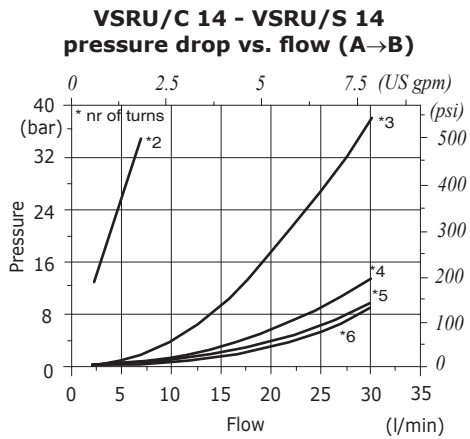

Rating diagrams

VSRU/C 14 pressure drop vs. flow (B→A)

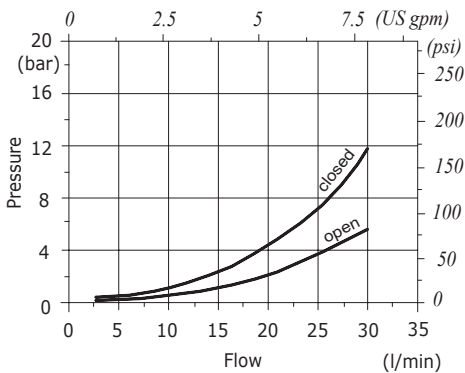

VSRU/C 38 pressure drop vs. flow (B→A)

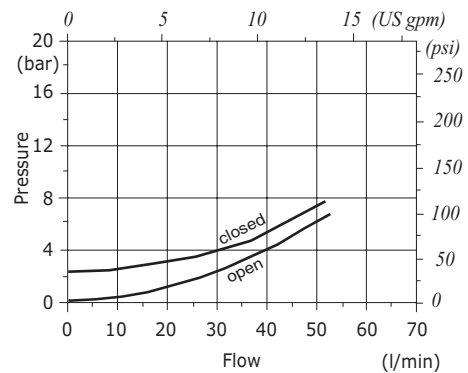

VSRU/C 12 pressure drop vs. flow (B→A)

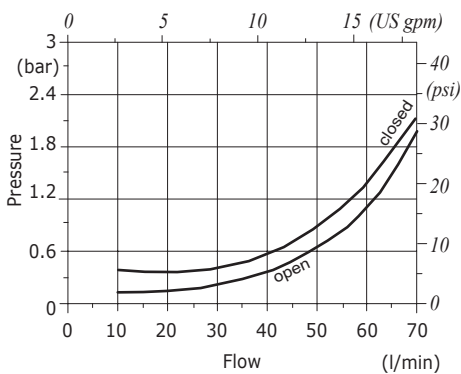

VSRU/C 34 pressure drop vs. flow (B→A)

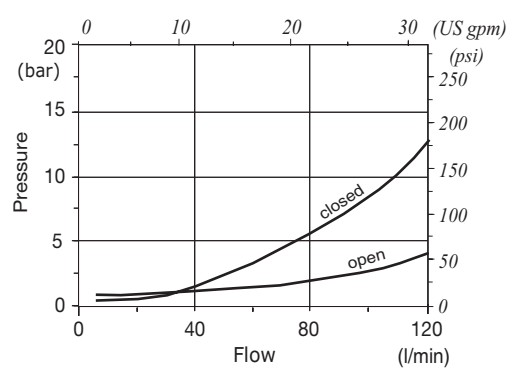

VSRU/C 100 pressure drop vs. flow (B→A)

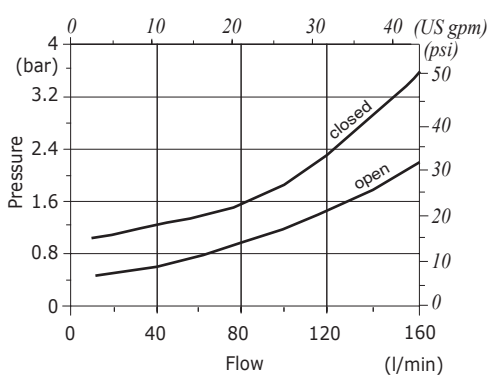

VSRU/C 114 pressure drop vs. flow (B→A)

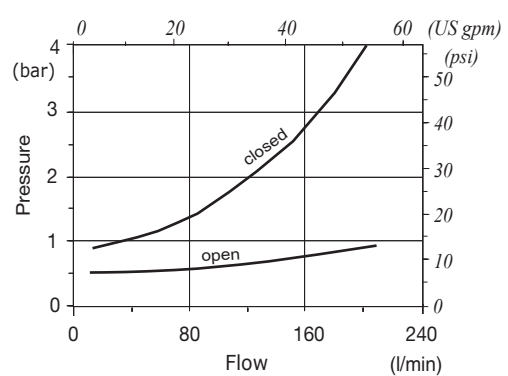

VSRU/C 112 pressure drop vs. flow (B→A)

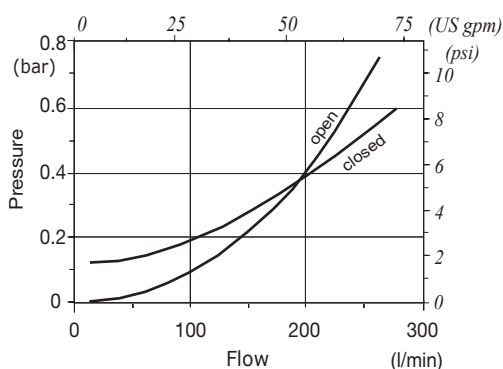

Rating diagrams

VSRU/S 14 pressure drop vs. flow (B→A)

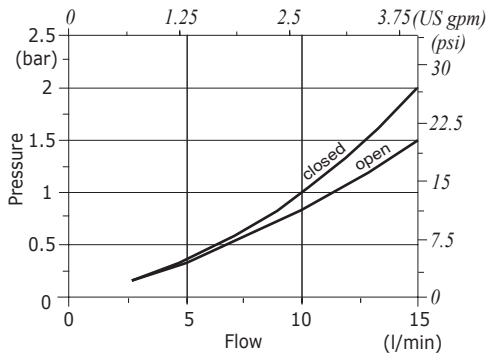

VSRU/S 38 pressure drop vs. flow (B→A)

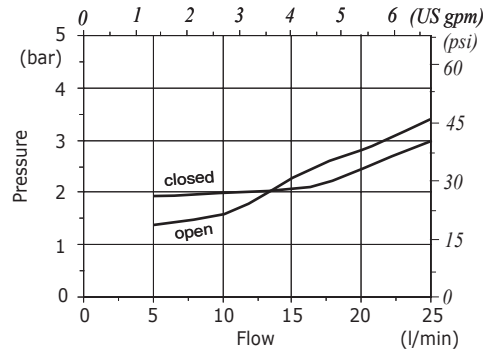

VSRU/S 12 pressure drop vs. flow (B→A)

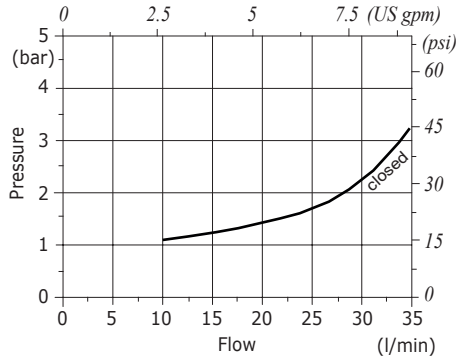

VSRU/S 34 pressure drop vs. flow (B→A)

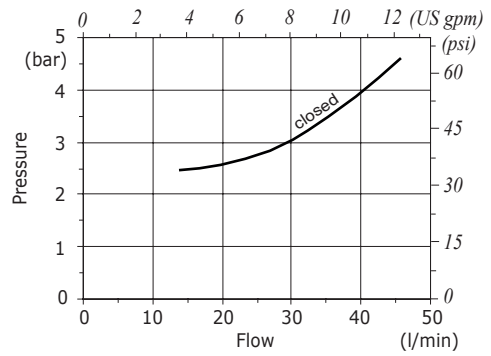



Type VSRB needle valves

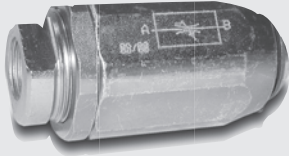

- Bidirectional

Technical specifications and diagrams are measured with mineral oil of 46 cSt viscosity at 40°C (104°F) temperature.

	VSRB 14	VSRB 38	VSRB 12	VSRB 34	VSRB 100	
Nominal flow from A to B	30 l/min (7.9 US gpm)	45 l/min (11.9 US gpm)	70 l/min (18.5 US gpm)	100 l/min (26.4 US gpm)	150 l/min (39.6 US gpm)	
Max. pressure	350 bar (5100 psi)	350 bar (5100 psi)	350 bar (5100 psi)	300 bar (4350 psi)	250 bar (3600 psi)	
Fluid	mineral based oil					
Viscosity	from 10 to 200 cSt					
Max. level of contamination	18/16/13 ISO4406					
Fluid temperature	with NBR seals: from -20°C (-4°F) to 80°C (176°F)					
Environmental temperature for working conditions	from -40°C (-40°F) to 100°C (212°F)					
Weight	steel	0.30 kg (0.66 lb)	0.48 kg (1.06 lb)	0.59 kg (1.3 lb)	1.34 kg (2.95 lb)	2.15 kg (4.74 lb)

NOTE - For different conditions, please contact Walvoil Sales Dpt.

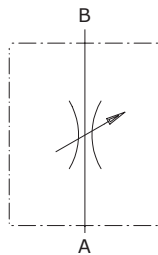

Dimensions

Dimensions are in mm-in

Valve type	All ports	A	⌀B	⌀c
VSRB 14	G 1/4	66-2.6	32	22
VSRB 38	G 3/8	77.5-3.05	38	26
VSRB 12	G 1/2	83-3.27	41	30
VSRB 34	G 3/4	104-4.09	55	38
VSRB 100	G 1"	118.5-4.66	65	46

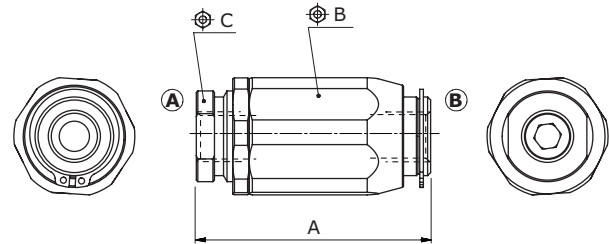

Ordering codes and description composition

Port size
VSRB 14

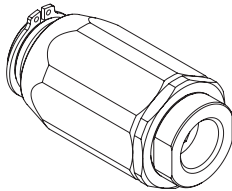

VSRB complete valves

TYPE	CODE	DESCRIPTION
VSRB 14	1603210100	Steel body, G1/4 ports
VSRB 38	1603220100	Steel body, G3/8 ports
VSRB 12	1603230100	Steel body, G1/2 ports
VSRB 34	1603240100	Steel body, G3/4 ports
VSRB 100	1603250100	Steel body, G1 ports

For different configurations or SAE thread please contact our Sales Dpt.

Rating diagram

VSRB 14 pressure drop vs. flow

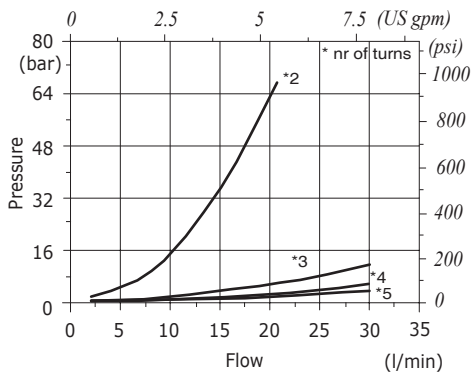

VSRB 38 pressure drop vs. flow

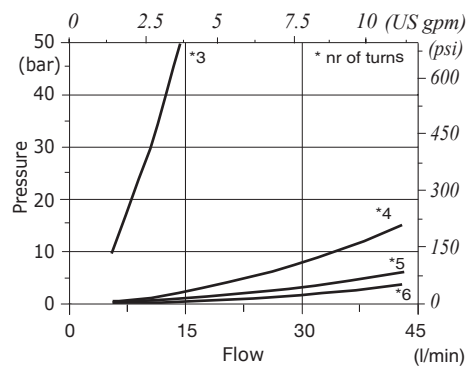

VSRB 12 pressure drop vs. flow

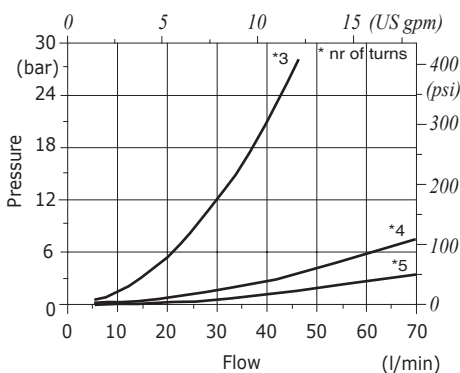

VSRB 34 pressure drop vs. flow

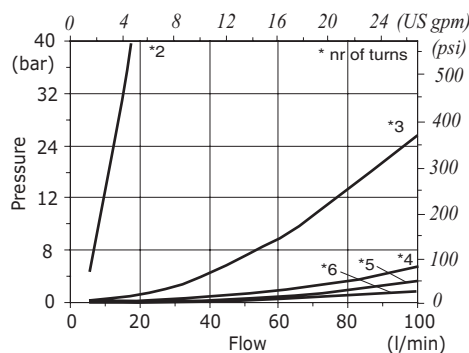

VSRB 100 pressure drop vs. flow

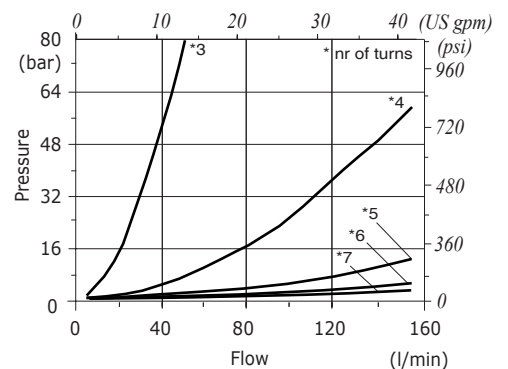



Type VRFB90 needle valves

- Bidirectional

Technical specifications and diagrams are measured with mineral oil of 46 cSt viscosity at 40°C (104°F) temperature.

	VRFB9001	VRFB9002	VRFB9003	VRFB9004	VRFB9005
Nominal flow	30 l/min (7.9 US gpm)	40 l/min (10.6 US gpm)	50 l/min (23.8 US gpm)	80 l/min (21.1 US gpm)	110 l/min (29.1 US gpm)
Max. pressure	350 bar (5100 psi)	350 bar (5100 psi)	350 bar (5100 psi)	320 bar (4600 psi)	300 bar (4350 psi)
Fluid	mineral based oil				
Viscosity	from 10 to 200 cSt				
Max. level of contamination	18/16/13 ISO4406				
Fluid temperature	with NBR seals from -30°C (-22°F) to 80°C (176°F)				
Environmental temperature for working conditions	from -40°C (-40°F) to 100°C (212°F)				
Weight	steel 0.34 kg (0.75 lb)	0.34 kg (0.75 lb)	0.43 kg (0.95 lb)	1.13 kg (2.49 lb)	1 kg (2.2 lb)

NOTE - For different conditions, please contact Walvoil Sales Dpt.

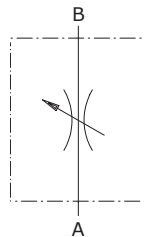

Dimensions

Dimensions are in mm-in

Valve type	All ports	A	B	C	D	E
VRFB9001	G1/4	58 - 2.28	82 - 3.23	25 - 0.98	30 - 1.18	M25X1.5
VRFB9002	G3/8	60 - 2.36	82 - 3.23	25 - 0.98	30 - 1.18	M25X1.5
VRFB9003	G1/2	64 - 2.52	88 - 3.46	30 - 1.18	30 - 1.18	M25X1.5
VRFB9004	G3/4	89 - 3.50	116 - 4.57	40 - 1.57	42 - 1.65	M35X1.5
VRFB9005	G1	89 - 3.50	116 - 4.57	40 - 1.57	42 - 1.65	M35X1.5

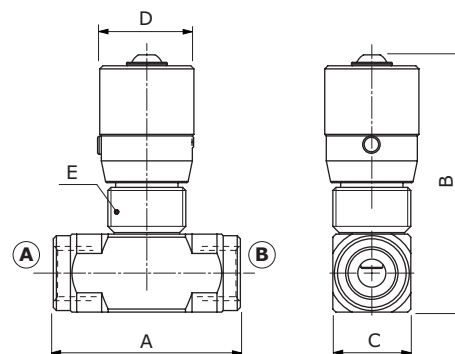

Ordering codes and description composition

VRBF90 01 └─ Port size

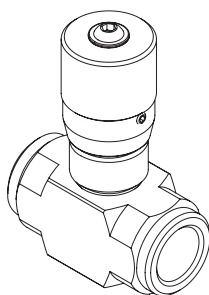

VRFB90 complete valves

TYPE	CODE	DESCRIPTION
VRFB9001	1605210100	Steel body, G1/4 ports
VRFB9002	1605220100	Steel body, G3/8 ports
VRFB9003	1605230100	Steel body, G1/2 ports
VRFB9004	1605240100	Steel body, G3/4 ports
VRFB9005	1605250100	Steel body, G1 ports

For different configurations or SAE thread please contact our Sales Dpt.

Rating diagram

VRFB9001
pressure drop vs. flow

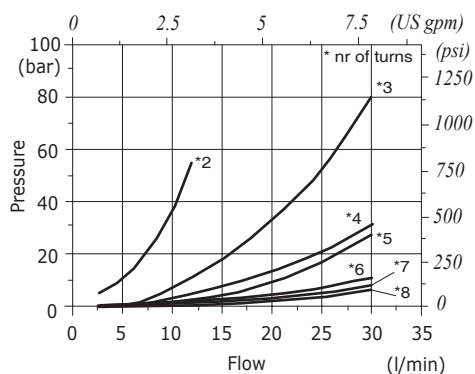

VRFB9002
pressure drop vs. flow

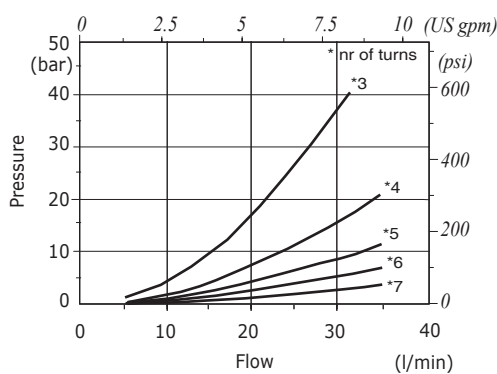

VRFB9003
pressure drop vs. flow

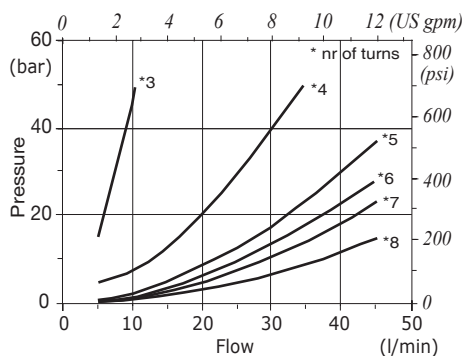

VRFB9004
pressure drop vs. flow

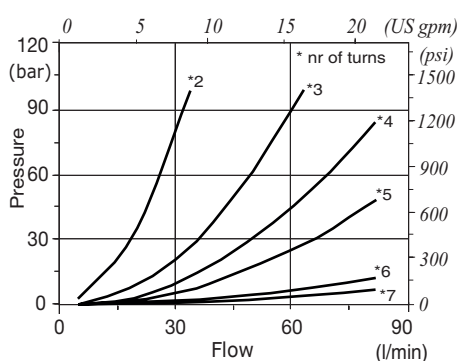

VRFB9005
pressure drop vs. flow

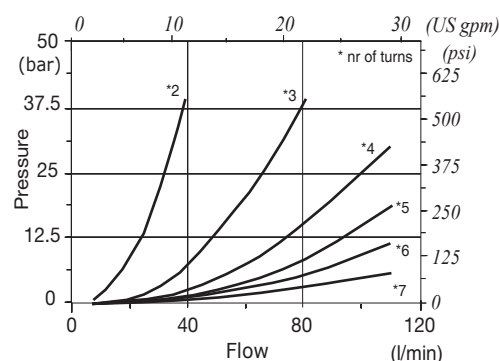



Type VRFU90 needle valves

- With check valve

Technical specifications and diagrams are measured with mineral oil of 46 cSt viscosity at 40°C (104°F) temperature.

	VRFU9001	VRFU9002	VRFU9003	VRFU9004	VRFU9005
Nominal flow from A to B	30 l/min (7.9 US gpm)	40 l/min (10.6 US gpm)	50 l/min (23.8 US gpm)	80 l/min (21.1 US gpm)	110 l/min (29.1 US gpm)
Nominal flow from B to A	35 l/min (9.2 US gpm)	50 l/min (23.8 US gpm)	90 l/min (23.8 US gpm)	140 l/min (37 US gpm)	180 l/min (47.6 US gpm)
Max. pressure	350 bar (5100 psi)	350 bar (5100 psi)	350 bar (5100 psi)	320 bar (4600 psi)	300 bar (4350 psi)
Fluid	mineral based oil				
Viscosity	from 10 to 200 cSt				
Max. level of contamination	18/16/13 ISO4406				
Fluid temperature	with NBR seals from -30°C (-22°F) to 80°C (176°F)				
Environmental temperature for working conditions	from -40°C (-40°F) to 100°C (212°F)				
Weight	steel 0.40 kg (0.88 lb)	0.41 kg (0.9 lb)	0.58 kg (1.28 lb)	1.39 kg (3.06 lb)	1.36 kg (3 lb)

NOTE - For different conditions, please contact Walvoil Sales Dpt.

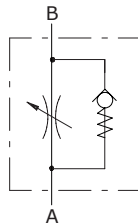

Dimensions

Dimensions are in mm-in

Valve type	All ports	A	B	C	D	E	F
VRFU9001	G1/4	75 - 2.95	82 - 3.23	25 - 0.98	29 - 1.14	M25X1.5	30 - 1.18
VRFU9002	G3/8	78 - 3.07	82 - 3.23	25 - 0.98	31 - 1.22	M25X1.5	30 - 1.18
VRFU9003	G1/2	93 - 3.66	88 - 3.46	30 - 1.18	33.5 - 1.32	M25X1.5	30 - 1.18
VRFU9004	G3/4	110 - 4.33	116 - 4.57	40 - 1.57	41.5 - 1.63	M35X1.5	42 - 1.65
VRFU9005	G1	135 - 5.31	116 - 4.57	40 - 1.57	44.5 - 1.75	M35X1.5	42 - 1.65

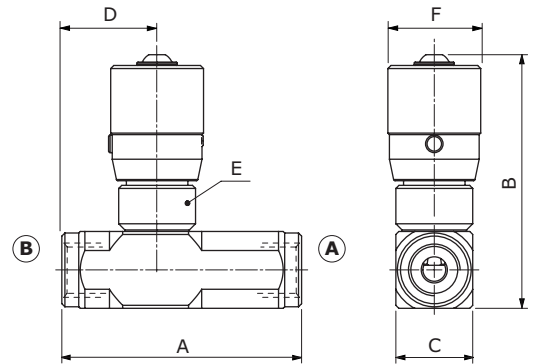

Ordering codes and description composition

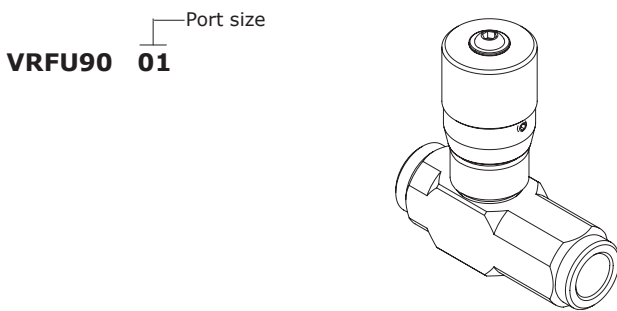

VRFU90 complete valves

TYPE	CODE	DESCRIPTION
VRFU9001	1605110100	Steel body, G1/4 ports, opening pressure 0.5 bar (7.25 psi)
VRFU9002	1605120100	Steel body, G3/8 ports, opening pressure 0.5 bar (7.25 psi)
VRFU9003	1605130100	Steel body, G1/2 ports, opening pressure 0.5 bar (7.25 psi)
VRFU9004	1605140100	Steel body, G3/4 ports, opening pressure 0.5 bar (7.25 psi)
VRFU9005	1605150100	Steel body, G1 ports, opening pressure 0.5 bar (7.25 psi)

For different configurations or SAE thread please contact our Sales Dpt.

Rating diagram

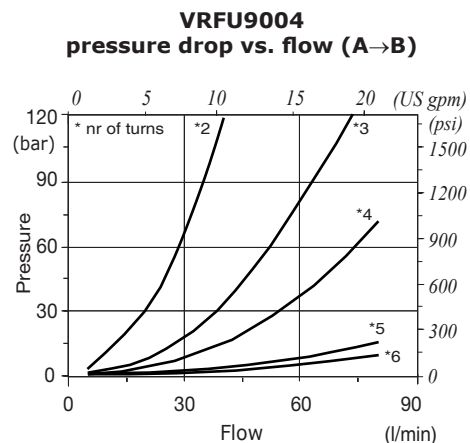
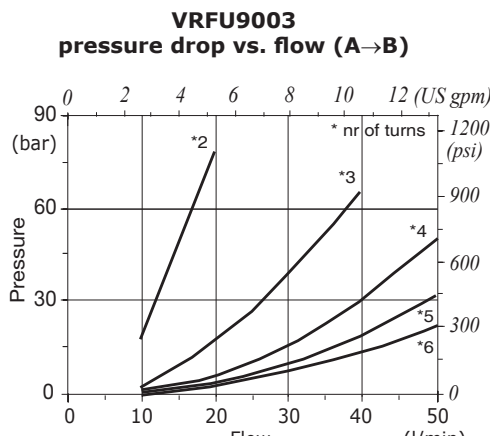
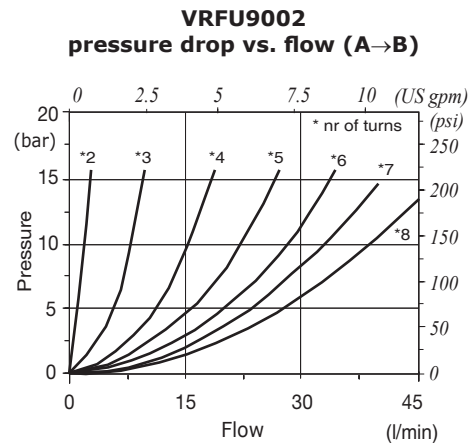
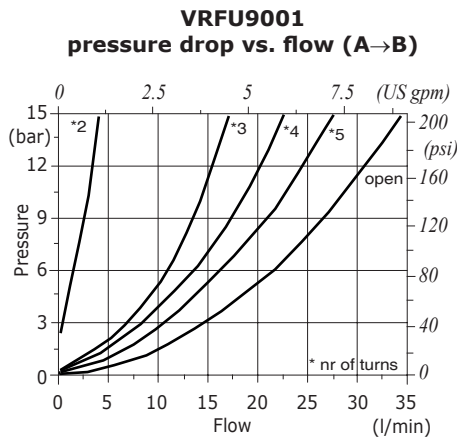

Rating diagram

VRFU9005
pressure drop vs. flow (A→B)

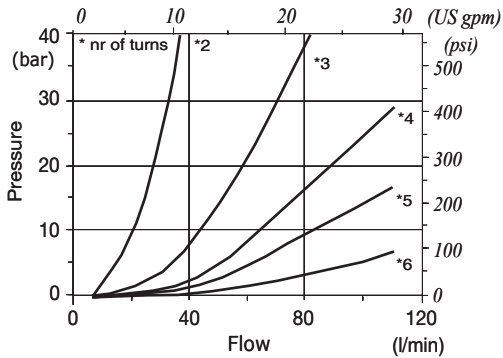

VRFU9001
pressure drop vs. flow (B→A)

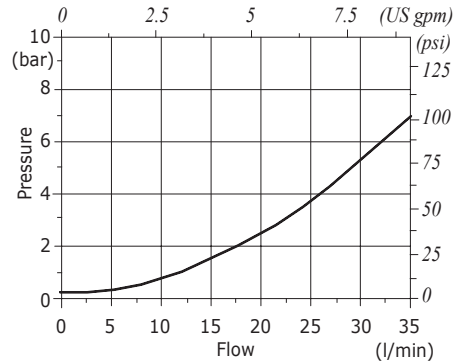

VRFU9002
pressure drop vs. flow (B→A)

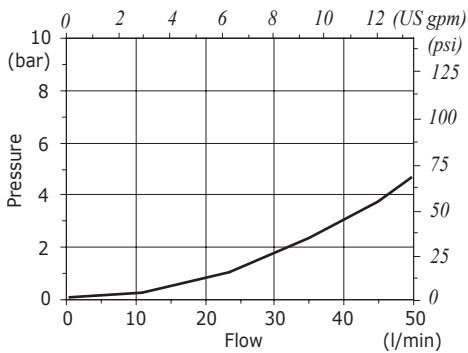

VRFU9003
pressure drop vs. flow (B→A)

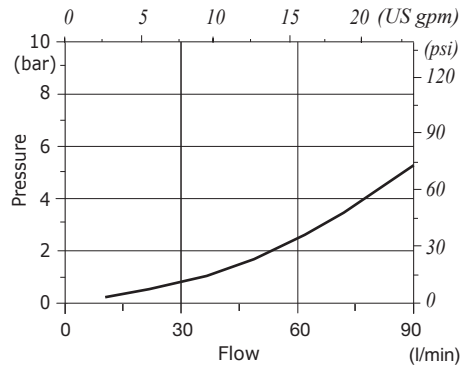

VRFU9004
pressure drop vs. flow (B→A)

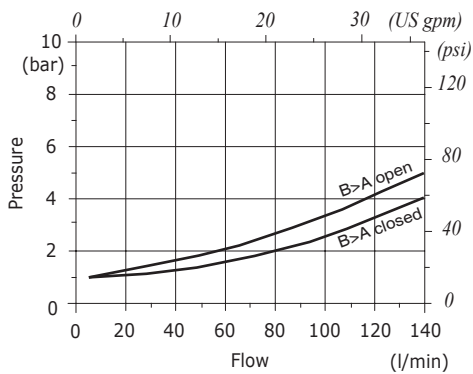

VRFU9005
pressure drop vs. flow (B→A)

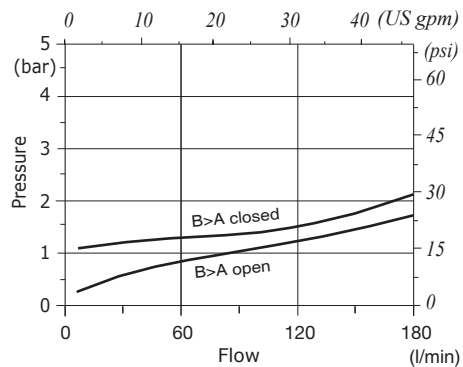



Type VPR/2/RL flow control pressure compensated valves

- 2 way
- With reverse free - flow check

Technical specifications and diagrams are measured with mineral oil of 46 cSt viscosity at 40°C (104°F) temperature.

	VPR/2/RL 38	VPR/2/RL 12	VPR/2/RL 34	VPR/2/RL 100	
Nominal flow "Qc"	30 l/min (7.9 US gpm)	50 l/min (13.2 US gpm)	90 l/min (23.8 US gpm)	150 l/min (39.6 US gpm)	
Nominal flow "SB"*	15 l/min (4.0 US gpm)	25 l/min (6.6 US gpm)	45 l/min (11.9 US gpm)	75 l/min (19.8 US gpm)	
Max. pressure	Aluminium body = 210 bar (3050 psi) Steel body = 350 bar (5100 psi)				
Fluid	mineral based oil				
Viscosity	from 10 to 200 cSt				
Max. level of contamination	18/16/13 ISO4406				
Fluid temperature	with NBR seals from -20°C (-4°F) to 80°C (176°F)				
Environmental temperature for working conditions	from -40°C (-40°F) to 100°C (212°F)				
Weight	aluminium	1.09 kg (2.40 lb)	1.06 kg (2.34 lb)	2.15 kg (4.73 lb)	5.14 kg (11.33 lb)
	steel	2.41 kg (5.31 lb)	2.43 kg (5.36 lb)	4.60 kg (10.14 lb)	11.13 kg (24.54 lb)

NOTE - For different conditions, please contact Walvoil Sales Dpt.

*"SB" execution (sensibilized adjustment)

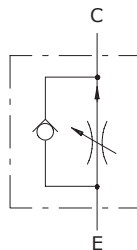

Dimensions

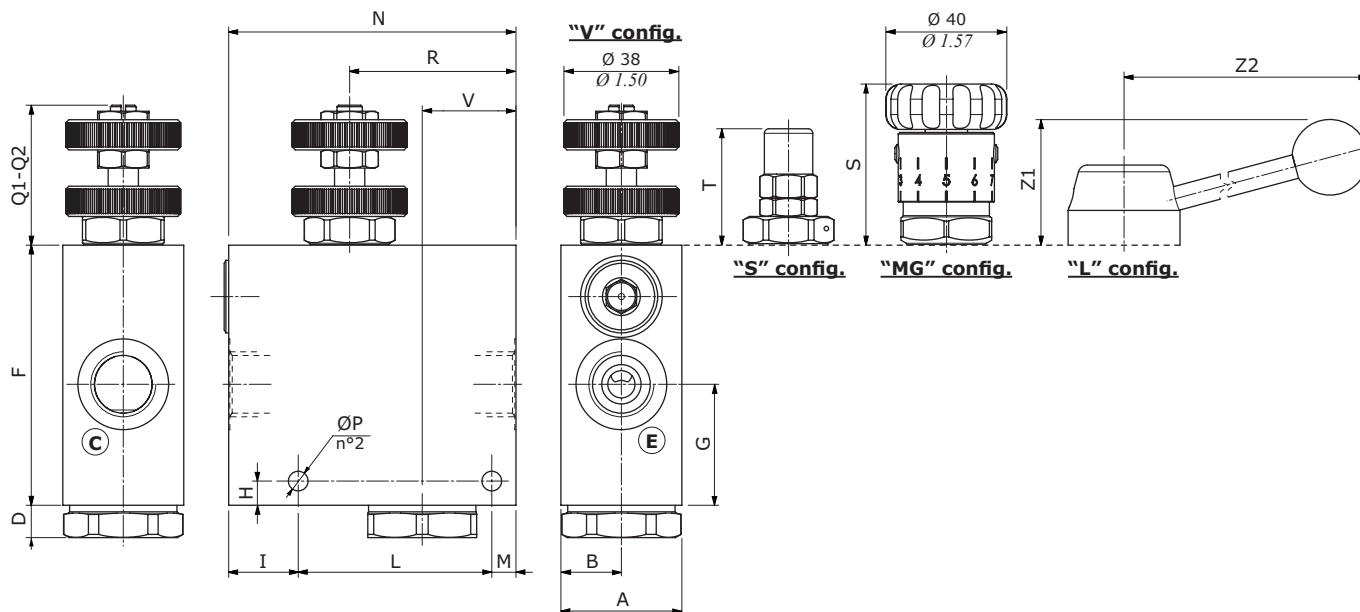

Valve type	All ports	Valve type	All ports
VPR/2/RL 38	G3/8	VPR/2/RL 38/SAE	SAE8
VPR/2/RL 12	G1/2	VPR/2/RL 12/SAE	SAE10
VPR/2/RL 34	G3/4	VPR/2/RL 34/SAE	SAE12
VPR/2/RL 100	G1"		

Dimensions are in mm-in

Valve type	A	B	D	F	G	H	I	L	M	N	ØP	Q1	Q2*	R	S	T	V	Z1	Z2
VPR/2/RL 38	40	20	11	86	40	8	23	64	8	95	6.5	46.3	52.6	55	53.3	38.5	23	47.6	101.3
VPR/2/RL 38/SAE	1.57	0.78	0.43	3.38	1.57	0.31	0.90	2.51	0.31	3.74	0.25	1.82	2.07	2.16	2.10	1.51	0.91	1.87	3.99
VPR/2/RL 12	40	20	11	86	40	8	23	64	8	95	6.5	46.3	53.1	55	53.3	38.5	23	47.6	101.3
VPR/2/RL 12/SAE	1.57	0.78	0.43	3.38	1.57	0.31	0.90	2.51	0.31	3.74	0.25	1.82	2.09	2.16	2.10	1.51	0.91	1.87	3.99
VPR/2/RL 34	50	25	10.5	100	47	10	38	84	8	130	8.5	41.5	50.5	72	49.50	38.5	30	50.1	103.6
VPR/2/RL 34/SAE	1.97	0.98	0.41	3.94	1.85	0.39	1.50	3.31	0.31	5.12	0.33	1.73	1.99	2.83	1.95	1.51	1.18	1.97	4.08
VPR/2/RL 100	70	35	13.5	140	58	10	50	100	10	160	10.5	52	-	91	52.5	41.5	37	50.5	107.3
	2.75	0.53	0.53	5.51	2.28	0.39	1.97	3.94	0.39	1.50	0.41	2.05		3.58	2.06	1.63	1.46	1.99	4.22

(*) For "SB" execution (sensibilized adjustment)

Flow control valves

Flow control pressure compensated valves

VPR/2/RL

Ordering codes and description composition

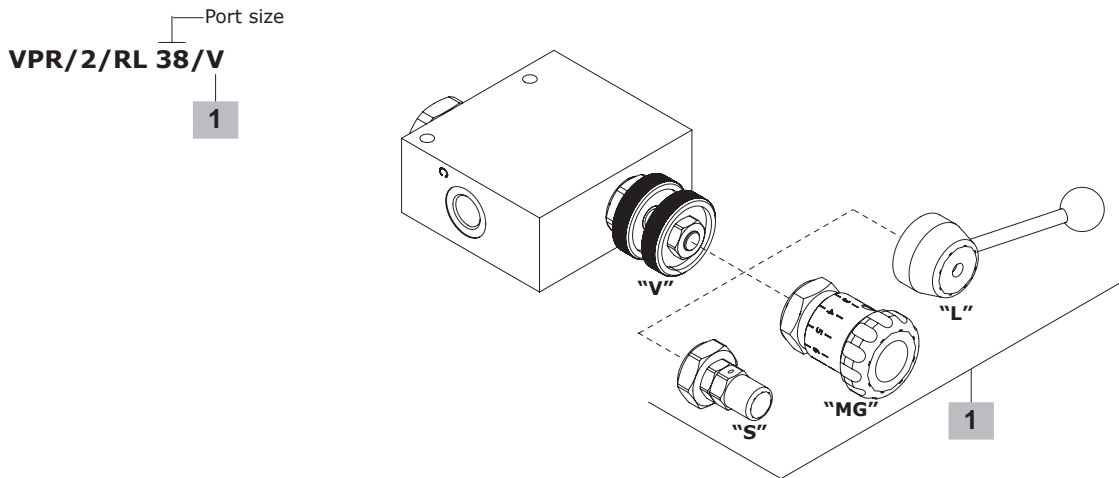

VPR/2/RL complete valves

TYPE	CODE	DESCRIPTION
Adjustment kit type "V" (handwheel)		
VPR/2/RL 38/V	1611021100	Aluminium body, G3/8 ports
VPR/2/RL 12/V	1611031100	Aluminium body, G1/2 ports
VPR/2/RL 34/V	1611041100	Aluminium body, G3/4 ports
VPR/2/RL 100/V	1611051100	Aluminium body, G1" ports
VPR/2/RL 38/V/ac	1611022100	Steel body, G3/8 ports
VPR/2/RL 12/V/ac	1611032100	Steel body, G1/2 ports
VPR/2/RL 34/V/ac	1611042100	Steel body, G3/4 ports
VPR/2/RL 100/V/ac	1611052100	Steel body, G1" ports
VPR/2/RL 38/V/SAE	1611021200	Aluminium body, SAE8 ports
VPR/2/RL 12/V/SAE	1611031200	Aluminium body, SAE10 ports
VPR/2/RL 34/V/SAE	1611041200	Aluminium body, SAE12 ports
Adjustment kit type "MG" (handknob)		
VPR/2/RL 38/MG	1611021101	Aluminium body G3/8 ports
VPR/2/RL 12/MG	1611031101	Aluminium body G1/2 ports
VPR/2/RL 34/MG	1611041101	Aluminium body G3/4 ports
VPR/2/RL 100/MG	1611051101	Aluminium body G1" ports
Adjustment kit type "L" (lever)		
VPR/2/RL 38/L	1611021102	Aluminium body G3/8 ports
VPR/2/RL 12/L	1611031102	Aluminium body G1/2 ports
VPR/2/RL 34/L	1611041102	Aluminium body G3/4 ports
VPR/2/RL 100/L	1611051102	Aluminium body G1" ports

For other steel body configurations, SAE thread and configurations with FPM (Viton) seals, please contact our Sales Dpt.

1 Adjustment kit

TYPE	CODE	DESCRIPTION
For VPR/2/RL 38 valve		
V.SB	5KT6200200	"V" handwheel type in "SB" configuration (sensibilized adjustment)
V	5KT6130200	"V" handwheel type
MG	5KT6200202	"MG" handknob type
S	5KT6200211	"S" screw type
For VPR/2/RL 12 valve		
V.SB	5KT6130301	"V" handwheel type in "SB" configuration (sensibilized adjustment)
V	5KT6130200	"V" handwheel type
MG	5KT6200202	"MG" handknob type
S	5KT6200211	"S" screw type
For VPR/2/RL 34 valve		
V	5KT6130401	"V" handwheel type
MG	5KT6200400	"MG" handknob type
S	5KT6130404	"S" screw type
V.SB	5KT6130402	"V" handwheel type in "SB" configuration (sensibilized adjustment)
For VPR/2/RL 100 valve		
V	5KT6340603	"V" handwheel type
MG	5KT6200605	"MG" handknob type
S	5KT6200604	"S" screw type

Rating diagrams

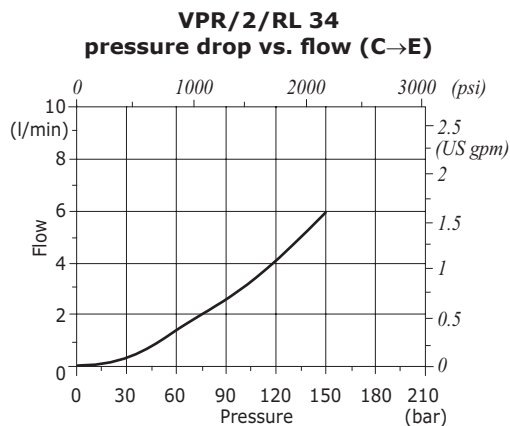
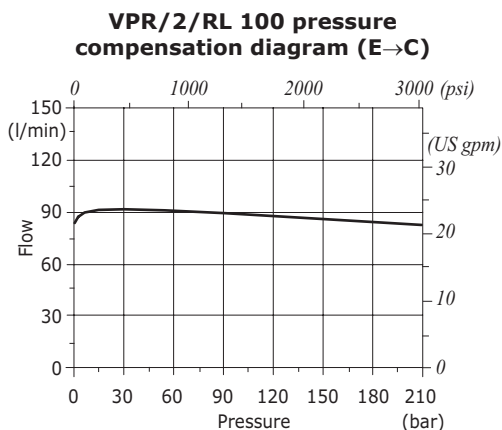
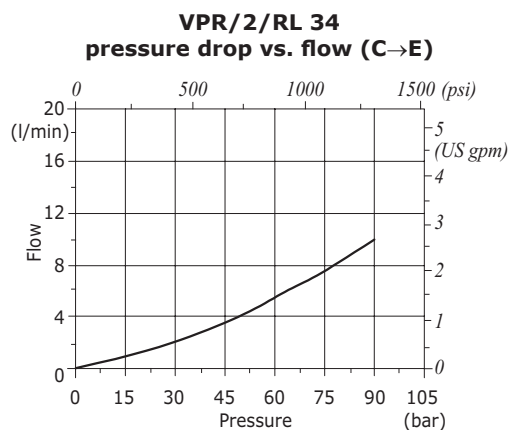
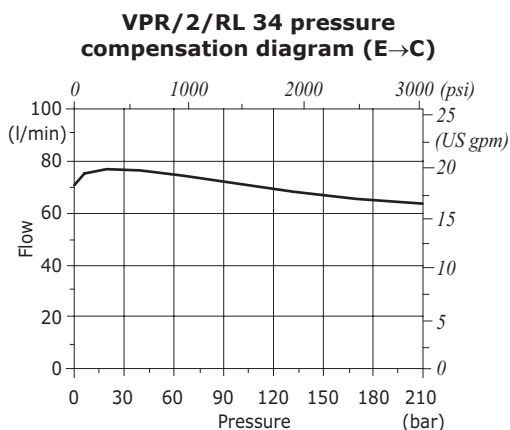
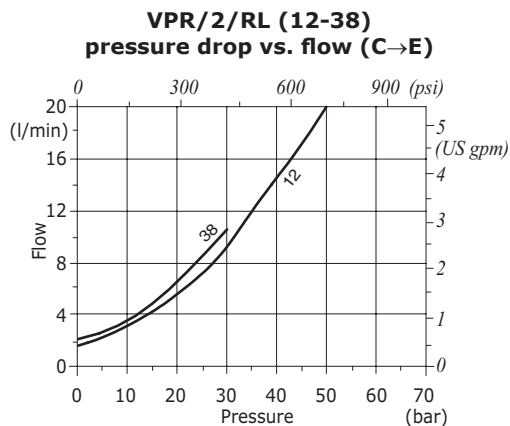
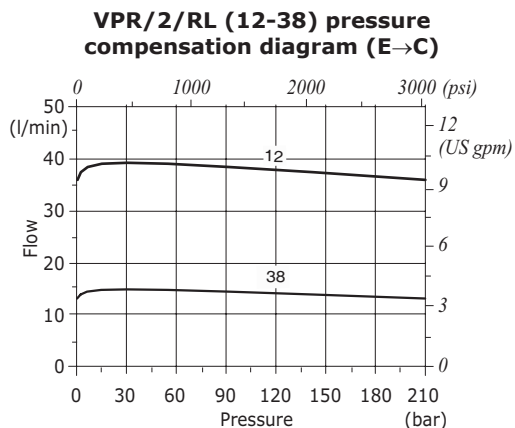

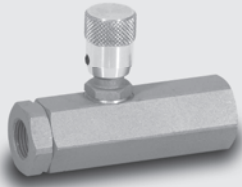

Type VPR/2/RL/EX flow control pressure compensated valves

- With check valve
- Compensated

Technical specifications and diagrams are measured with mineral oil of 46 cSt viscosity at 40°C (104°F) temperature.

	VPR/2/RL/EX 14/V	VPR/2/RL/EX 38/V	VPR/2/RL/EX 12/V
Nominal flow	17 l/min (4.5 US gpm)	17 l/min (4.5 US gpm)	35 l/min (9.2 US gpm)
Nominal flow from B to A	25 l/min (6.6 US gpm)	30 l/min (7.9 US gpm)	45 l/min (11.9 US gpm)
Max. pressure	300 bar (4350 psi)	300 bar (4350 psi)	250 bar (3600 psi)
Fluid	mineral based oil		
Viscosity	from 10 to 200 cSt		
Max. level of contamination	18/16/13 ISO4406		
Fluid temperature	with NBR seals from -20°C (-4°F) to 80°C (176°F)		
Environmental temperature for working conditions	from -40°C (-40°F) to 100°C (212°F)		
Weight	steel 0.52 kg (1.15 lb)	0.50 kg (1.1 lb)	0.69 kg (1.52 lb)

NOTE - For different conditions, please contact Walvoil Sales Dpt.

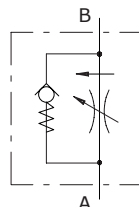

Dimensions

Dimensions are in mm-in

Valve type	All ports	A	B	C	D	⌀E
VPR/2/RL/EX 14/V	G1/4	87 - 3.42	52.5 - 2.07	68 - 2.68	20 - 0.79	32
VPR/2/RL/EX 38/V	G3/8	87 - 3.42	52.5 - 2.07	68 - 2.68	20 - 0.79	32
VPR/2/RL/EX 12/V	G1/2	107 - 4.21	61 - 2.40	71 - 2.79	20 - 0.79	36

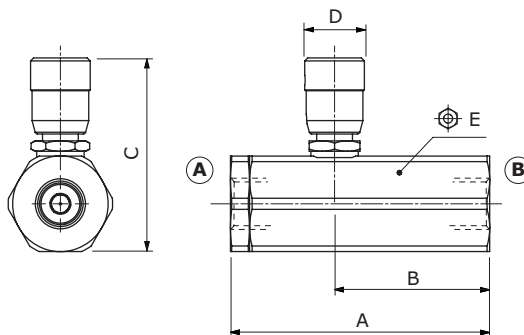

Ordering codes and description composition

Port size
VPR/2/RL/EX 14/V

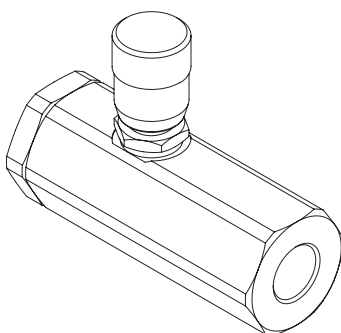

VRFU90C complete valves

TYPE	CODE	DESCRIPTION
VPR/2/RL/EX 14/V	1605510100	Steel body, G1/4 ports
VPR/2/RL/EX 38/V	1605520100	Steel body, G3/8 ports
VPR/2/RL/EX 12/V	1605530100	Steel body, G1/2 ports

For other steel body configurations or SAE thread please contact our Sales Dpt.

Rating diagram

VPR/2/RL/EX 14/V - VPR/2/RL/EX 38/V
pressure drop vs. flow compensated (A→B)

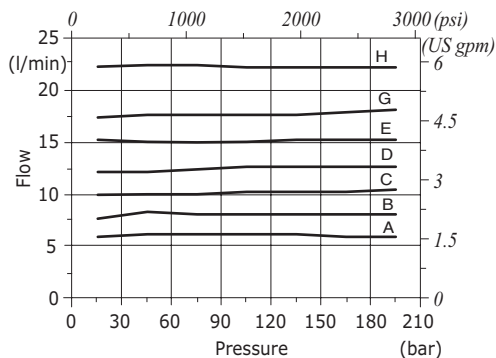

VPR/2/RL/EX 12/V
pressure drop vs. flow compensated (A→B)

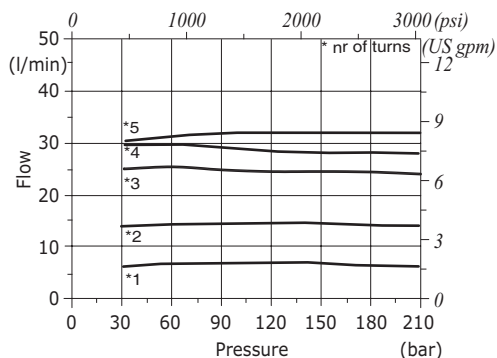

VPR/2/RL/EX 14/V
pressure drop vs. flow (B→A)

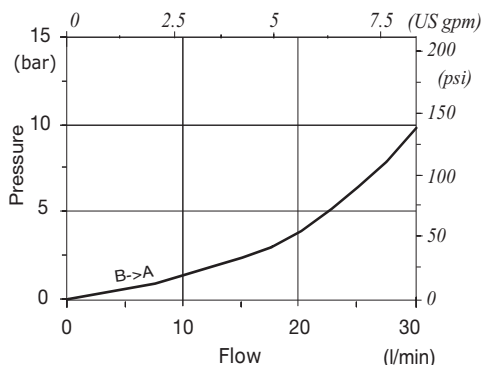

VPR/2/RL/EX 38/V
pressure drop vs. flow (B→A)

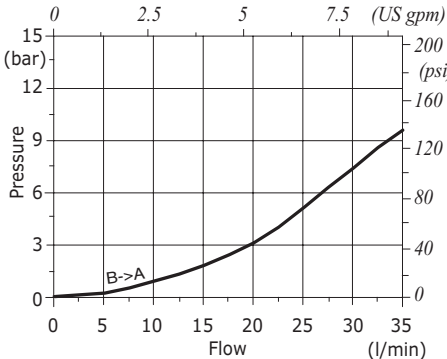

VPR/2/RL/EX 12/V
pressure drop vs. flow (B→A)

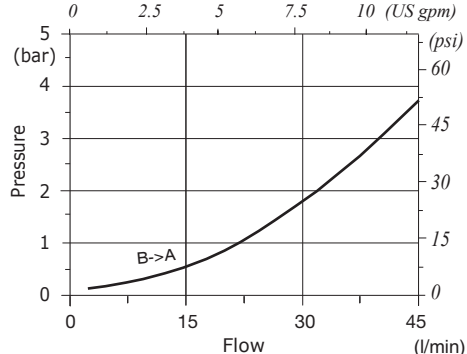



Type VPR/2/U flow control pressure compensated valves

- 2 ways

Technical specifications and diagrams are measured with mineral oil of 46 cSt viscosity at 40°C (104°F) temperature.

	VPR/2/U 38	VPR/2/U 12	VPR/2/U 34	VPR/2/U 100	
Nominal flow "Qc"	30 l/min (7.9 US gpm)	50 l/min (13.2 US gpm)	90 l/min (23.8 US gpm)	150 l/min (39.6 US gpm)	
Nominal flow "SB"*	15 l/min (4.0 US gpm)	25 l/min (6.6 US gpm)	45 l/min (11.9 US gpm)	75 l/min (19.8 US gpm)	
Max. pressure	Aluminium body = 210 bar (3050 psi) Steel body = 350 bar (5100 psi)				
Fluid	mineral based oil				
Viscosity	from 10 to 200 cSt				
Max. level of contamination	18/16/13 ISO4406				
Fluid temperature	with NBR seals from -20°C (-4°F) to 80°C (176°F) with FPM seals from -20°C (-4°F) to 100°C (212°F)				
Environmental temperature for working conditions	from -40°C (-40°F) to 100°C (212°F)				
Weight	aluminium	0.87 kg (1.91 lb)	0.88 kg (1.94 lb)	1.74 kg (3.84 lb)	3.96 kg (8.73 lb)
	steel	1.92 kg (4.23 lb)	1.99 kg (4.39 lb)	3.56 kg (7.85 lb)	7.80 kg (17.20 lb)

NOTE - For different conditions, please contact Walvoil Sales Dpt.

*"SB" execution (sensibilized adjustment)

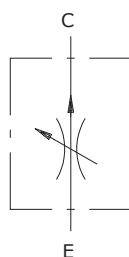

Dimensions

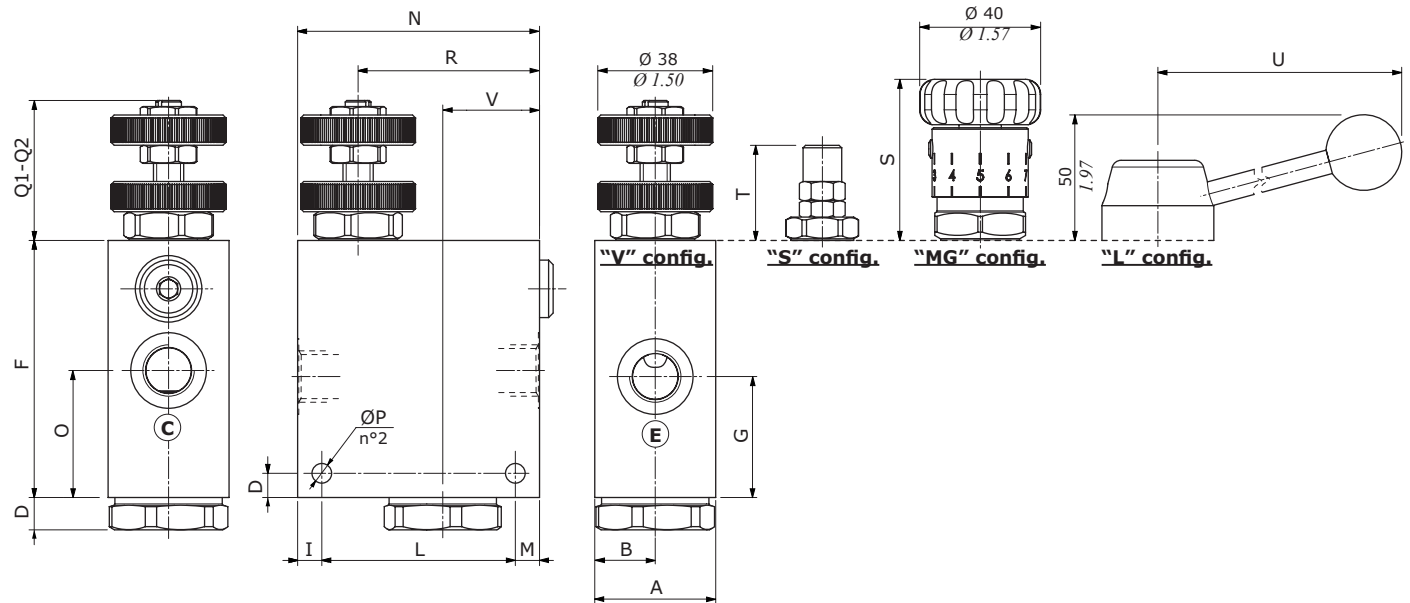

Valve type	All ports	Valve type	All ports
VPR/2/U 38	G3/8	VPR/2/U 38/SAE	SAE8
VPR/2/U 12	G1/2	VPR/2/U 12/SAE	SAE10
VPR/2/U 34	G3/4		
VPR/2/U 100	G1"		

Dimensions are in mm-in

Valve type	A	B	D	F	G	H	I	L	M	N	O	ØP	Q1	Q2*	R	S	T	U	V
VPR/2/U 38	40	20	10.7	85	40	8	8	64	8	80	40.5	6.5	46.3	52.6	60	53.3	38.5	50	103.3
VPR/2/U 38/SAE	1.57	0.78	0.42	3.35	1.57	0.315	0.315	2.51	0.315	3.14	1.59	0.256	1.82	2.07	2.36	2.10	1.51	1.97	3.99
VPR/2/U 12	40	20	10.7	85	40	8	8	64	8	80	42	6.5	46.3	53.1	60	53.3	38.5	50	103.3
VPR/2/U 12/SAE	1.57	0.78	0.42	3.35	1.57	0.315	0.315	2.51	0.315	3.14	1.65	0.256	1.82	2.09	2.36	2.10	1.51	1.97	3.99
VPR/2/U 34	50	25	10.7	100	44	10	8	84	8	100	44	8.5	41.5	50.5	72	56.5	38.5	50	103.3
	1.97	0.98	0.42	3.94	1.73	0.39	0.315	3.31	0.315	3.94	1.73	0.335	1.73	1.99	2.83	2.22	1.51	1.97	3.99
VPR/2/U 100	70	35	13.5	140	58	10	10	100	10	120	58	10.5	52	-	92	56.5	41.5	50	107
	2.75	0.53	0.53	5.51	2.28	0.394	0.394	3.94	0.39	4.72	2.28	0.413	2.05		3.62	2.22	1.63	1.97	4.21

*"SB" execution (sensibilized adjustment)

Flow control valves

Flow control pressure compensated valves

VPR/2/U

Ordering codes and description composition

Port size
VPR/2/U 38/V
1

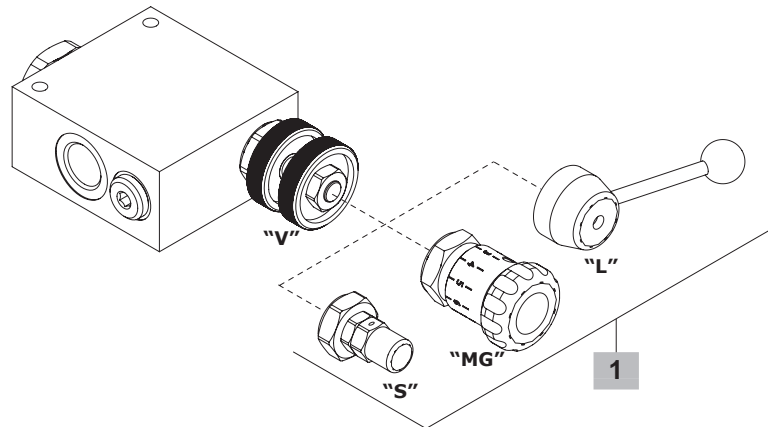

VPR/2/U complete valves

TYPE	CODE	DESCRIPTION
Adjustment kit type "V" (handwheel)		
VPR/2/U 38/V	1613021100	Aluminium body, 3/8 ports
VPR/2/U 12/V	1613031100	Aluminium body, 1/2 ports
VPR/2/U 34/V	1613041100	Aluminium body, 3/4 ports
VPR/2/U 100/V	1613051100	Aluminium body, 1" ports
VPR/2/U 38/V/ac	1613022100	Steel body, 3/8 ports
VPR/2/U 12/V/ac	1613032100	Steel body, 1/2 ports
VPR/2/U 34/V/ac	1613042100	Steel body, 3/4 ports
VPR/2/U 100/V/ac	1613052100	Steel body, 1" ports
VPR/2/U 38/V/SAE	1613021200	Aluminium body, SAE8 ports
VPR/2/U 12/V/SAE	1613031200	Aluminium body, SAE10 ports
Adjustment kit type "MG" (handknob)		
VPR/2/U 38/MG	1613021101	Aluminium body, 3/8 ports
VPR/2/U 12/MG	1613031101	Aluminium body, 1/2 port
VPR/2/U 34/MG	1613041101	Aluminium body, 3/4 ports
VPR/2/RL 100/MG	1613051101	Aluminium body, 1" ports
VPR/2/U 12/MG/SAE	1613031201	Aluminium body, SAE10 port
VPR/2/RL 100/MG/SAE	1613051200	Aluminium body, SAE16 ports
Adjustment kit type "L" (lever)		
VPR/2/U 38/L	1613021102	Aluminium body, 3/8 ports
VPR/2/U 12/L	1613031102	Aluminium body, 1/2 ports
VPR/2/U 34/L	1613041102	Aluminium body, 3/4 ports
VPR/2/U 100/L	1613051102	Aluminium body, 1" ports

For other steel body configurations, SAE thread and configurations with FPM (Viton) seals, please contact our Sales Dpt.

1 Adjustment kit

TYPE	CODE	DESCRIPTION
For VPR/2/RL 38 valve		
V.SB	5KT6200200	"V" handwheel type in "SB" configuration (sensibilized adjustment)
V	5KT6130200	"V" handwheel type
MG	5KT6200202	"MG" handknob type
S	5KT6200211	"S" screw type
For VPR/2/RL 12 valve		
V.SB	5KT6130301	"V" handwheel type in "SB" configuration (sensibilized adjustment)
V	5KT6130200	"V" handwheel type
MG	5KT6200202	"MG" handknob type
S	5KT6200211	"S" screw type
For VPR/2/RL 34 valve		
V	5KT6130401	"V" handwheel type
MG	5KT6200400	"MG" handknob type
S	5KT6130404	"S" screw type
V.SB	5KT6130402	"V" handwheel type in "SB" configuration (sensibilized adjustment)
For VPR/2/RL 100 valve		
V	5KT6340603	"V" handwheel type
MG	5KT6200605	"MG" handknob type
S	5KT6200604	"S" screw type

Rating diagrams

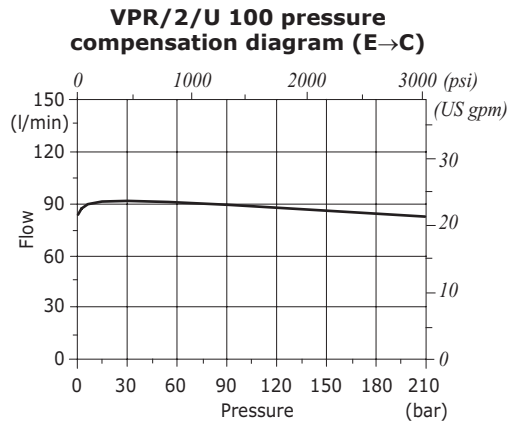
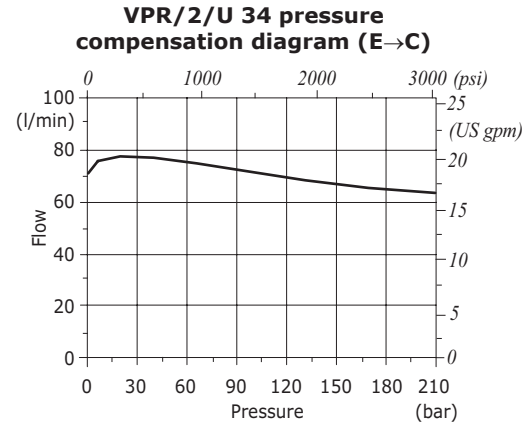
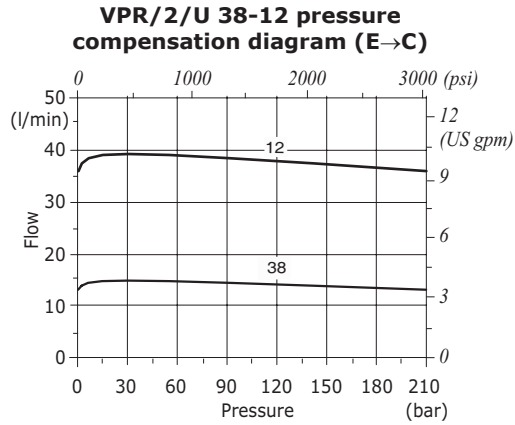

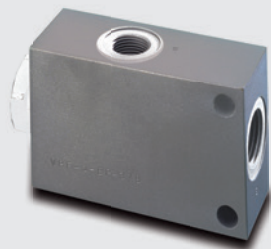

Type VPF/3/EP flow control pressure compensated valves

- 3 ways
- Exceeding flow to pressure
- Whit costant flow in "C"

Technical specifications and diagrams are measured with mineral oil of 46 cSt viscosity at 40°C (104°F) temperature.

	VPF/3/EP 38	VPF/3/EP 12	VPF/3/EP 34	
Nominal flow	60 l/min (15.8 US gpm)	100 l/min (26.4 US gpm)	150 l/min (39.6 US gpm)	
Max. pressure	Aluminium body = 210 bar (3050 psi) Steel body = 350 bar (5100 psi)			
Fluid	mineral based oil			
Viscosity	from 10 to 200 cSt			
Max. level of contamination	18/16/13 ISO4406			
Fluid temperature	with NBR seals from -20°C (-4°F) to 80°C (176°F) with FPM seals from -20°C (-4°F) to 100°C (212°F)			
Environmental temperature for working conditions	from -40°C (-40°F) to 100°C (212°F)			
Weight	aluminium	0.62 kg (1.37 lb)	0.85 kg (1.87 lb)	1.68 kg (3.70 lb)
	steel	1.35 kg (2.98 lb)	2.18 kg (4.81 lb)	3.71 kg (8.18 lb)

NOTE - For different conditions, please contact Walvoil Sales Dpt.

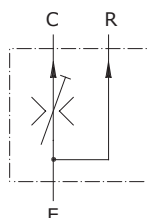

Dimensions

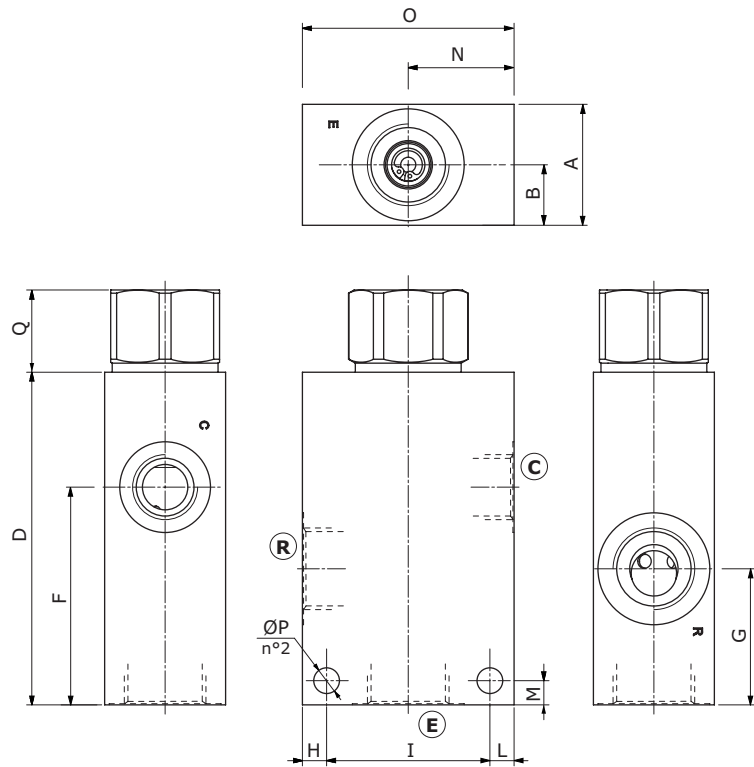

Valve type	E	R	C
VPF/3/EP 38	G1/2	G3/8	G3/8
VPF/3/EP 12	G3/4	G3/4	G1/2
VPF/3/EP 34	1"	1"	G3/4

Dimensions are in mm-in

Valve type	A	B	D	F	G	H	I	L	M	N	O	$\varnothing P$	Q
VPF/3/EP 38	35 1.38	17.5 0.69	95 3.74	55 2.16	35 1.38	8 0.31	44 1.73	8 0.315	8 0.315	30 1.18	60 2.36	8.5 0.335	10 0.394
VPF/3/EP 12	40 1.57	20 0.79	110 4.33	72 2.83	45 1.77	8 0.315	54 2.12	8 0.315	8 0.315	35 1.38	70 2.75	8.5 0.335	27.2 1.07
VPF/3/EP 34	50 1.97	25 0.98	120 4.72	80 3.14	50 1.97	10 0.39	70 2.75	10 0.394	10 0.394	45 1.77	90 3.54	10.5 0.413	24.5 0.96

Ordering codes and description composition

Port size
VPF/3/EP 38/Ds1
1

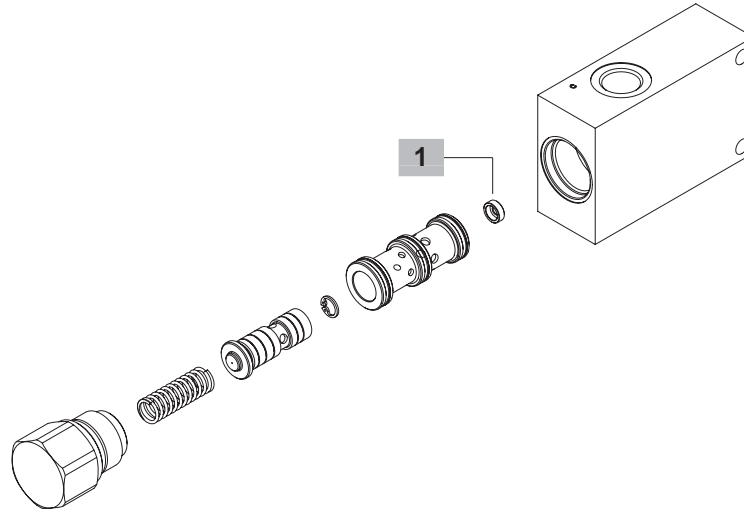

VPF/3/EP complete valves

TYPE: **VPF/3/EP 38/Ds1** CODE: 1640021100
 DESCRIPTION: Aluminium body, G3/8 ports, fixed orifice Ø1 mm-0.039 in (Qc 1.2 l/min-0.31 US gpm)

TYPE: **VPF/3/EP 12/Ds2** CODE: 1640031102
 DESCRIPTION: Aluminium body, G1/2 ports, fixed orifice Ø2 mm-0.078 in (Qc 4 l/min-1.05 US gpm)

TYPE: **VPF/3/EP 34/Ds3** CODE: 1640041105
 DESCRIPTION: Aluminium body, G3/4 ports, fixed orifice Ø3 mm-0.12 in (Qc 11 l/min-2.9 US gpm)

TYPE: **VPF/3/EP 38/Ds2,5/ac** CODE: 1640022100
 DESCRIPTION: Steel body, G3/8 ports, fixed orifice Ø2.5 mm-0.14 in (Qc 7.5 l/min-1.98 US gpm)

TYPE: **VPF/3/EP 12/Ds3/ac** CODE: 1640032103
 DESCRIPTION: Steel body, G1/2 ports, fixed orifice Ø3 mm-0.12 in (Qc 11 l/min-2.9 US gpm)

TYPE: **VPF/3/EP 34/Ds4/ac** CODE: 1640042100
 DESCRIPTION: Steel body, G3/4 ports, fixed orifice Ø4 mm-0.16 in (Qc 20.5 l/min-5.41 US gpm)

For other steel body configurations, SAE thread and configurations with FPM (Viton) seals, please contact our Sales Dpt.

1 Fixed orifice

TYPE	CODE	DESCRIPTION
For VPF/3/EP 38 valve		
Ds1	3DF1091000	Ø1 mm-0.039 in (Qc 1.2 l/min-0.31 US gpm)
Ds1,5	3DF1091500	Ø1.5 mm-0.059 in (Qc 2.8 l/min-0.73 US gpm)
Ds2	3DF1092000	Ø2 mm-0.079 in (Qc 5 l/min-1.32 US gpm)
Ds2,5	3DF1092500	Ø2.5 mm-0.098 in (Qc 7.5 l/min-1.98 US gpm)
Ds2,8	3DF1092800	Ø2.8 mm-0.11 in (Qc 9.5 l/min-2.5 US gpm)
Ds3	3DF1093000	Ø3 mm-0.12 in (Qc 11 l/min-2.9 US gpm)
Ds3,5	3DF1093500	Ø3.5 mm-0.14 in (Qc 16 l/min-4.2 US gpm)
Ds3,8	3DF1093800	Ø3.8 mm-0.15 in (Qc 20 l/min-5.9 US gpm)
Ds4	3DF1094000	Ø4 mm-0.16 in (Qc 23 l/min-6 US gpm)
For VPF/3/EP 12 valve		
Ds1	3DF1111000	Ø1 mm-0.039 in (Qc 1.1 l/min-0.29 US gpm)
Ds1,5	3DF1111500	Ø1.5 mm-0.059 in (Qc 2.5 l/min-0.66 US gpm)
Ds2	3DF1112000	Ø2 mm-0.079 in (Qc 4 l/min-1.05 US gpm)
Ds2,5	3DF1112500	Ø2.5 mm-0.098 in (Qc 6.5 l/min-1.72 US gpm)
Ds2,8	3DF1112800	Ø2.8 mm-0.11 in (Qc 8 l/min-2.1 US gpm)
Ds3	3DF1113000	Ø3 mm-0.12 in (Qc 9.5 l/min-2.5 US gpm)
Ds3,5	3DF1113500	Ø3.5 mm-0.14 in (Qc 13 l/min-3.43 US gpm)
Ds3,8	3DF1113800	Ø3.8 mm-0.15 in (Qc 16 l/min-4.22 US gpm)
Ds4	3DF1114000	Ø4 mm-0.16 in (Qc 18 l/min-4.75 US gpm)
Ds4,5	3DF1114500	Ø4.5 mm-0.18 in (Qc 25 l/min-6.6 US gpm)
Ds5	3DF1115000	Ø5 mm-0.2 in (Qc 32 l/min-8.45 US gpm)
Ds5,5	3DF1115000	Ø5.5 mm-1.2 in (Qc 41 l/min-10.83 US gpm)
For VPF/3/EP 34 valve		
Ds1	3DF1151000	Ø1 mm-0.039 in (Qc 1.3 l/min-0.34 US gpm)
Ds1,5	3DF1151500	Ø1.5 mm-0.059 in (Qc 3 l/min-0.4 US gpm)
Ds2	3DF1152000	Ø2 mm-0.079 in (Qc 5 l/min-1.32 US gpm)
Ds2,5	3DF1152500	Ø2.5 mm-0.14 in (Qc 7.5 l/min-1.98 US gpm)
Ds3	3DF1153000	Ø3 mm-0.15 in (Qc 11 l/min-2.9 US gpm)
Ds3,5	3DF1153500	Ø3.5 mm-0.15 in (Qc 15 l/min-3.96 US gpm)
Ds4	3DF1154000	Ø4 mm-0.16 in (Qc 20.5 l/min-5.41 US gpm)
Ds4,5	3DF1154500	Ø4.5 mm-0.18 in (Qc 26.5 l/min-7 US gpm)
Ds5	3DF1155000	Ø5 mm-0.2 in (Qc 33 l/min-8.72 US gpm)
Ds5,5	3DF1155500	Ø5.5 mm-1.2 in (Qc 42 l/min-11.09 US gpm)
Ds6	3DF1156000	Ø6 mm-0.18 in (Qc 52 l/min-13.74 US gpm)
Ds6,5	3DF1156500	Ø6.5 mm-0.2 in (Qc 63 l/min-16.64 US gpm)
Ds7	3DF1157000	Ø7 mm-1.2 in (Qc 77 l/min-20.34 US gpm)

Rating diagrams

**VPF/3/EP 38 compensation diagram in C
changing the Δp between E and R**

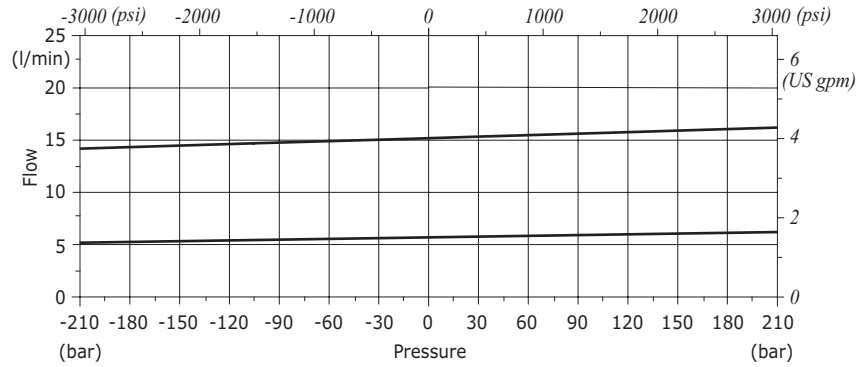

**VPF/3/EP 12 compensation diagram in C
changing the Δp between E and R**

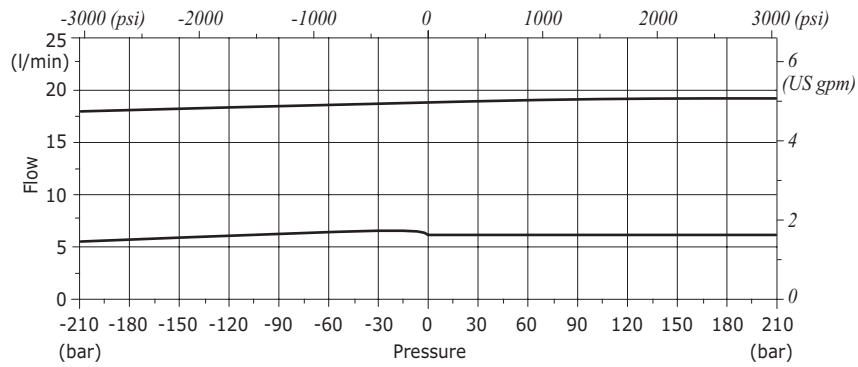

**VPF/3/EP 34 compensation diagram in C
changing the Δp between E and R**

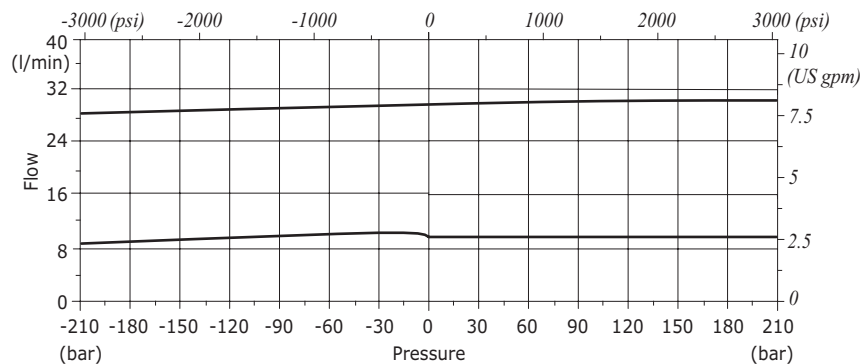

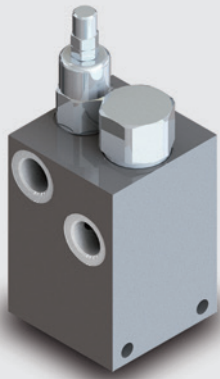

Type VPF/3/EP+VMP flow control pressure compensated valves

- 3 ways
- Exceeding flow to pressure
- Whit costant flow in "C"
- With pressure relief valve

Technical specifications and diagrams are measured with mineral oil of 46 cSt viscosity at 40°C (104°F) temperature.

	VPF/3/EP 38+VMP	VPF/3/EP 12+VMP	VPF/3/EP 34+VMP	
Nominal flow	60 l/min (15.8 US gpm)	100 l/min (26.4 US gpm)	150 l/min (39.6 US gpm)	
Max. pressure	Aluminium body = 210 bar (3050 psi) Steel body = 350 bar (5100 psi)			
Fluid	mineral based oil			
Viscosity	from 10 to 200 cSt			
Max. level of contamination	18/16/13 ISO4406			
Fluid temperature	with NBR seals from -20°C (-4°F) to 80°C (176°F)			
Environmental temperature for working conditions	from -40°C (-40°F) to 100°C (212°F)			
Weight	aluminium	1.30 kg (2.87 lb)	1.90 kg (4.19 lb)	3.15 kg (6.94 lb)
	steel	2.94 kg (6.48 lb)	4.38 kg (9.66 lb)	6.92 kg (15.26 lb)

NOTE - For different conditions, please contact Walvoil Sales Dpt.

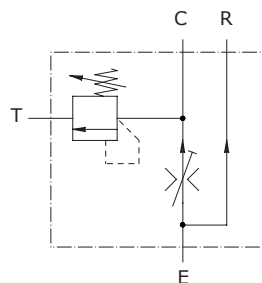

Dimensions

VPF/3/EP 38+VMP - VPF/3/EP 12+VMP

Valve type	E	R	C	T
VPF/3/EP 35+VMP	G1/2	G3/8	G3/8	G3/8
VPF/3/EP 12+VMP	G3/4	G3/4	G1/2	G1/2
VPF/3/EP 34+VMP	G1"	G1"	G3/4	G3/4

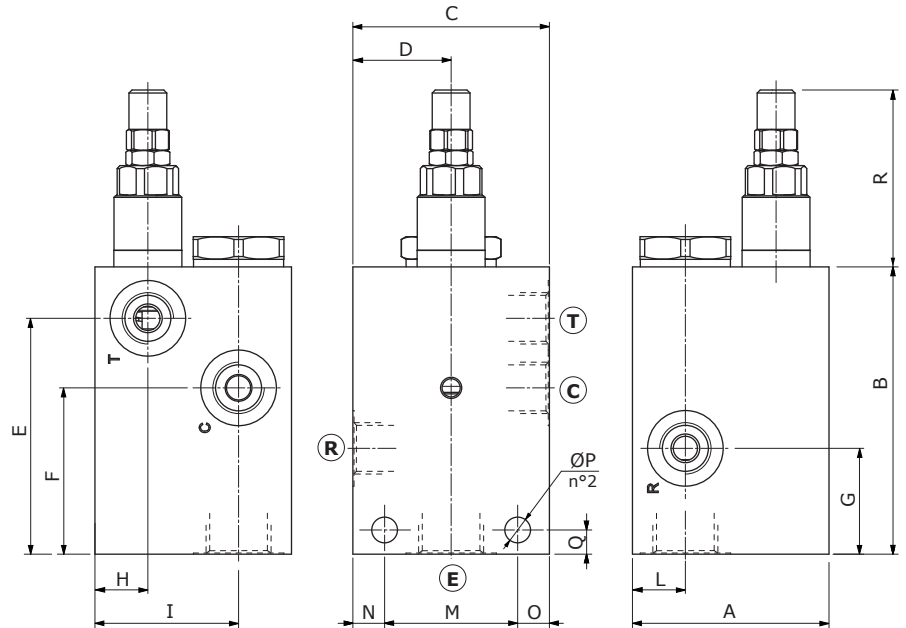

VPF/3/EP 34+VMP

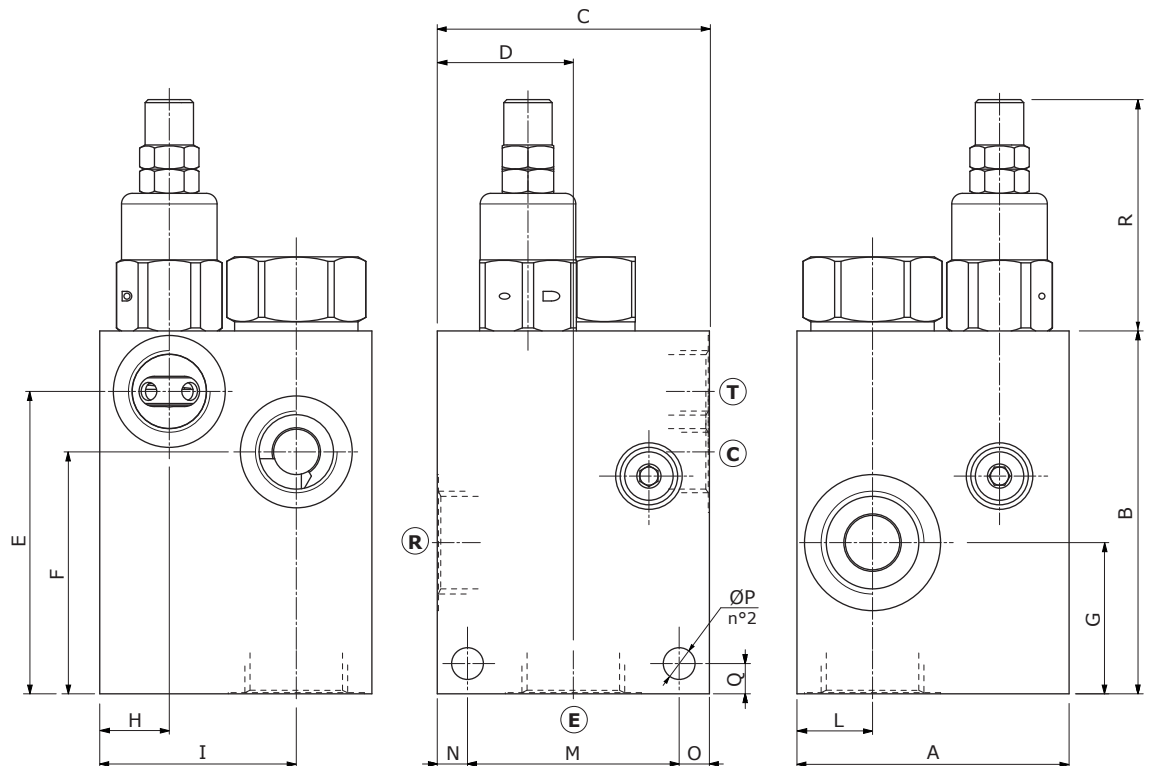

Dimensions are in mm-in

Valve type	A	B	C	D	E	F	G	H	I	L	M	N	O	ØP	Q	R
VPF/3/EP 38+VMP	65	95	65	32.5	78	55	35	17.5	47.5	17.5	44	10.5	10.5	8.5	8	58.5
	2.56	3.74	2.56	1.28	3.07	2.17	1.38	0.69	1.87	0.69	1.73	0.413	0.413	0.335	0.315	2.30
VPF/3/EP 12+VMP	75	110	75	37.5	92.5	72	45	17.5	55	20	54	10.5	10.5	8.5	8	67
	2.95	4.33	2.95	1.48	3.64	2.83	1.77	0.69	2.17	0.79	2.13	0.413	0.413	0.335	0.315	2.64
VPF/3/EP 34+VMP	90	120	90	45	100	80	50	23	65	25	70	10	10	10.5	10	76.5
	3.54	4.72	3.54	1.77	3.94	3.15	1.97	0.91	2.56	0.98	2.76	0.394	0.394	0.413	0.394	3.01

Flow control valves

Flow control pressure compensated valves

VPF/3/EP+VMP

Ordering codes and description composition

Port size
VPF/3/EP 38+VMP/Ds1/5.TS
 1 2 3

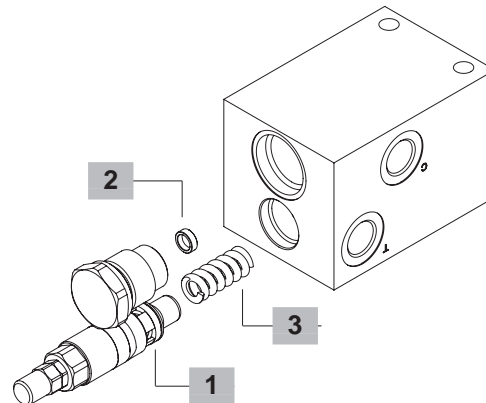

VPF/3/EP complete valves

TYPE: **VPF/3/EP 38+VMP/Ds1/5.TS** CODE: 1642021100
 DESCRIPTION: Aluminium body, G3/8 ports, fixed orifice Ø1 mm-0.039 in (Qc 1.2 l/min-0.31 US gpm), range 50-220 bar (725-3200 psi)

TYPE: **VPF/3/EP 12+VMP/Ds2/10.TS** CODE: 1642031102
 DESCRIPTION: Aluminium body, G1/2 ports, fixed orifice Ø2 mm-0.078 in (Qc 4 l/min-1.05 US gpm), range 50-220 bar (725-3200 psi)

TYPE: **VPF/3/EP 34+VMP/Ds3/20.TS** CODE: 1642041105
 DESCRIPTION: Aluminium body, G3/4 ports, fixed orifice Ø3 mm-0.12 in (Qc 11 l/min-2.9 US gpm), range 50-220 bar (725-3200 psi)

TYPE: **VPF/3/EP 38+VMP/Ds1/5.TS/ac** CODE: 1642022101
 DESCRIPTION: Steel body, 3/8 ports, fixed orifice Ø1 mm-0.039 in (Qc 1.2 l/min-0.31 US gpm), range 50-220 bar (725-3200 psi)

TYPE: **VPF/3/EP 12+VMP/Ds2/10.TS/ac** CODE: 1642032100
 DESCRIPTION: Steel body, 1/2 ports, fixed orifice Ø2 mm-0.078 in (Qc 4 l/min-1.05 US gpm), range 50-220 bar (725-3200 psi)

TYPE: **VPF/3/EP 34+VMP/Ds3/20.TS/ac** CODE: 1642042103
 DESCRIPTION: Steel body, 3/4 ports, fixed orifice Ø3 mm-0.12 in (Qc 11 l/min-2.9 US gpm) range 50-220 bar (725-3200 psi)

For other steel body configurations, SAE thread and configurations with FPM (Viton) seals, please contact our Sales Dpt.

3 Pressure setting springs

TYPE	CODE	DESCRIPTION
For VPF/3/EP 38+VMP valve		
TB	3MOL314311	Setting range 5-40 bar (72.5-580 psi)
TV	3MOL314330	Setting range 20-80 bar (290-1150 psi)
TS	3MOL315330	Setting range 50-220 bar (725-3200 psi)
TR	3ML1143600	Setting range 180-350 bar (2600-5075 psi)
For VPF/3/EP 12+VMP valve		
TB	3MOL316410	Setting range 5-40 bar (72.5-580 psi)
TV	3ML1154300	Setting range 20-80 bar (290-1150 psi)
TS	3MOL317420	Setting range 50-220 bar (725-3200 psi)
TR	3MOL317440	Setting range 180-350 bar (2600-5075 psi)
For VPF/3/EP 34+VMP valve		
TB	3ML1184300	Setting range 5-40 bar (72.5-580 psi)
TV	3ML1174500	Setting range 20-80 bar (290-1150 psi)
TS	3ML1204200	Setting range 50-220 bar (725-3200 psi)
TR	3ML1214500	Setting range 180-350 bar (2600-5075 psi)

1 Direct acting pressure relief valves

TYPE	CODE	DESCRIPTION
VMP 5/TS.S	1100520400	For VPF/3/EP 38+VMP valve Setting range 50-220 bar (725-3200 psi)
VMP 10/TS.S	1100530400	For VPF/3/EP 12+VMP valve Setting range 50-220 bar (725-3200 psi)
VMP 20/TS.S	1100540400	For VPF/3/EP 34+VMP valve Setting range 50-220 bar (725-3200 psi)

2 Fixed orifice

TYPE	CODE	DESCRIPTION
For VPF/3/EP 38+VMP valve		
Ds1	3DF1091000	Ø1 mm-0.039 in (Qc 1.2 l/min-0.31 US gpm)
Ds1,5	3DF1091500	Ø1.5 mm-0.059 in (Qc 2.8 l/min-0.73 US gpm)
Ds2	3DF1092000	Ø2 mm-0.079 in (Qc 5 l/min-1.32 US gpm)
Ds2,5	3DF1092500	Ø2.5 mm-0.098 in (Qc 7.5 l/min-1.98 US gpm)
Ds2,8	3DF1092800	Ø2.8 mm-0.11 in (Qc 9.5 l/min-2.5 US gpm)
Ds3	3DF1093000	Ø3 mm-0.12 in (Qc 11 l/min-2.9 US gpm)
Ds3,5	3DF1093500	Ø3.5 mm-0.14 in (Qc 16 l/min-4.2 US gpm)
Ds3,8	3DF1093800	Ø3.8 mm-0.15 in (Qc 20 l/min-5.9 US gpm)
Ds4	3DF1094000	Ø4 mm-0.16 in (Qc 23 l/min-6 US gpm)
For VPF/3/EP 12+VMP valve		
Ds1	3DF1111000	Ø1 mm-0.039 in (Qc 1.1 l/min-0.29 US gpm)
Ds1,5	3DF1111500	Ø1.5 mm-0.059 in (Qc 2.5 l/min-0.66 US gpm)
Ds2	3DF1112000	Ø2 mm-0.079 in (Qc 4 l/min-1.05 US gpm)
Ds2,5	3DF1112500	Ø2.5 mm-0.098 in (Qc 6.5 l/min-1.72 US gpm)
Ds2,8	3DF1112800	Ø2.8 mm-0.11 in (Qc 8 l/min-2.1 US gpm)
Ds3	3DF1113000	Ø3 mm-0.12 in (Qc 9.5 l/min-2.5 US gpm)
Ds3,5	3DF1113500	Ø3.5 mm-0.14 in (Qc 13 l/min-3.43 US gpm)
Ds3,8	3DF1113800	Ø3.8 mm-0.15 in (Qc 16 l/min-4.22 US gpm)
Ds4	3DF1114000	Ø4 mm-0.16 in (Qc 18 l/min-4.75 US gpm)
Ds4,5	3DF1114500	Ø4.5 mm-0.18 in (Qc 25 l/min-6.6 US gpm)
Ds5	3DF1115000	Ø5 mm-0.2 in (Qc 32 l/min-8.45 US gpm)
Ds5,5	3DF1115000	Ø5.5 mm-0.2 in (Qc 41 l/min-10.83 US gpm)
For VPF/3/EP 34+VMP valve		
Ds1	3DF1151000	Ø1 mm-0.039 in (Qc 1.3 l/min-0.34 US gpm)
Ds1,5	3DF1151500	Ø1.5 mm-0.059 in (Qc 3 l/min-0.4 US gpm)
Ds2	3DF1152000	Ø2 mm-0.079 in (Qc 5 l/min-1.32 US gpm)
Ds2,5	3DF1152500	Ø2,5 mm-0.14 in (Qc 7.5 l/min-1.98 US gpm)
Ds3	3DF1153000	Ø3 mm-0.15 in (Qc 11 l/min-2.9 US gpm)
Ds3,5	3DF1153500	Ø3,5 mm-0.15 in (Qc 15 l/min-3.96 US gpm)
Ds4	3DF1154000	Ø4 mm-0.16 in (Qc 20.5 l/min-5.41 US gpm)
Ds4,5	3DF1154500	Ø4.5 mm-0.18 in (Qc 26.5 l/min-7 US gpm)
Ds5	3DF1155000	Ø5 mm-0.2 in (Qc 33 l/min-8.72 US gpm)
Ds5,5	3DF1155500	Ø5.5 mm-0.2 in (Qc 42 l/min-11.09 US gpm)
Ds6	3DF1156000	Ø6 mm-0.18 in (Qc 52 l/min-13.74 US gpm)
Ds6,5	3DF1156500	Ø6.5 mm-0.2 in (Qc 63 l/min-16.64 US gpm)
Ds7	3DF1157000	Ø7 mm-0.2 in (Qc 77 l/min-20.34 US gpm)

Rating diagrams

VPF/3/EP 38+VMP compensation diagram in C changing the Δp between E and R

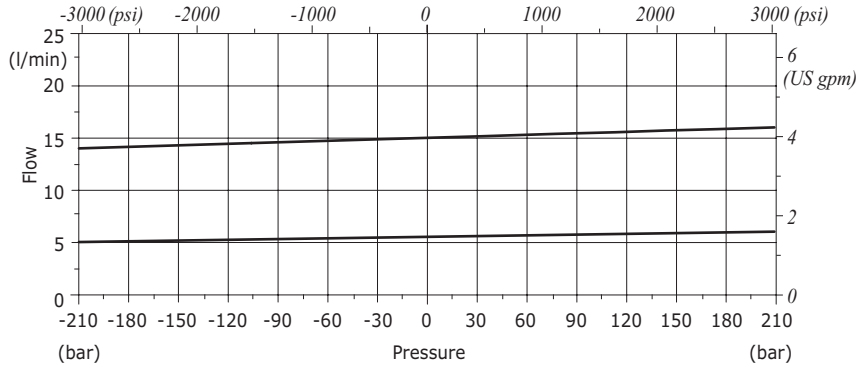

VPF/3/EP 38+VMP
Std. setting at 5 l/min (1.32 US gpm)

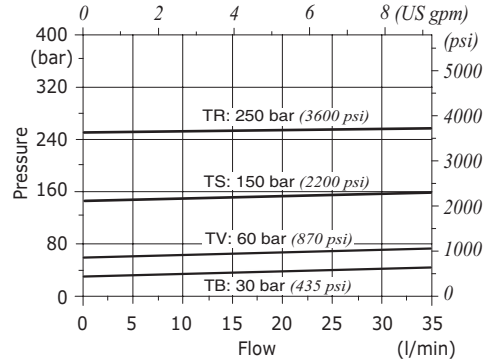

VPF/3/EP 12+VMP compensation diagram in C changing the Δp between E and R

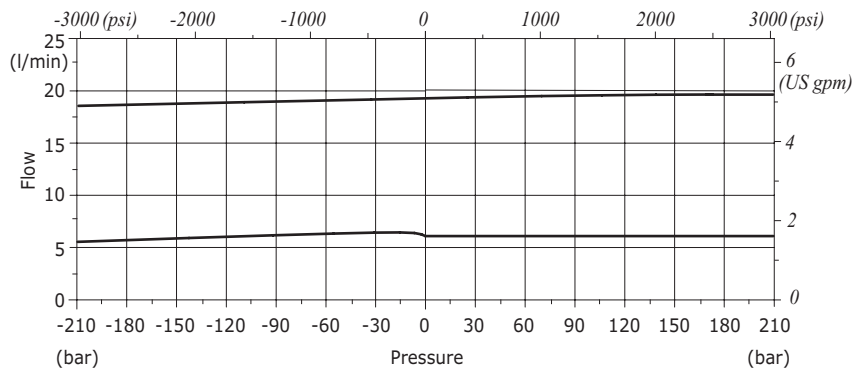

VPF/3/EP 12+VMP
Std. setting at 5 l/min (1.32 US gpm)

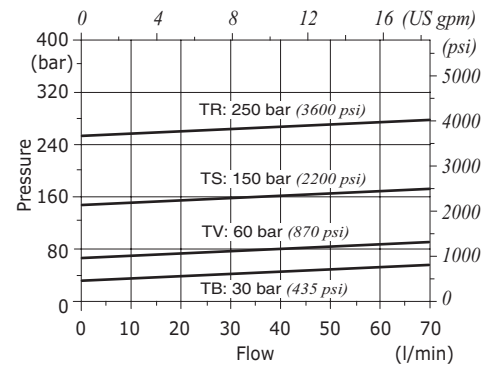

VPF/3/EP 34+VMP compensation diagram in C changing the Δp between E and R

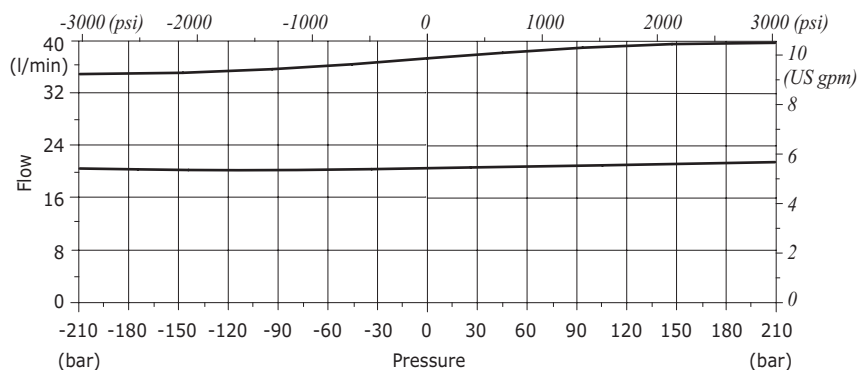

VPF/3/EP 34+VMP
Std. setting at 5 l/min (1.32 US gpm)

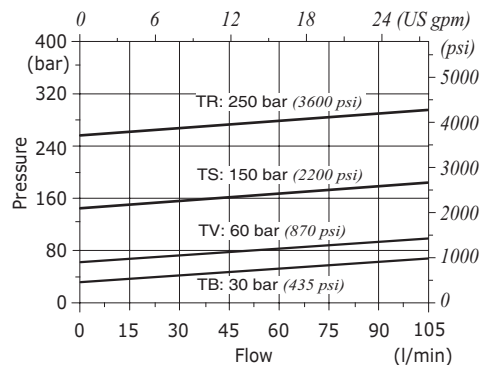



Type VPR/3/ET flow control pressure compensated valves

- 3 ways

Technical specifications and diagrams are measured with mineral oil of 46 cSt viscosity at 40°C (104°F) temperature.

		VPR/3/ET 38	VPR/3/ET 12	VPR/3/ET 34	VPR/3/ET 100	VPR/3/ET 114
Max. inlet flow	Line E	50 l/min (13.2 US gpm)	90 l/min (23.8 US gpm)	150 l/min (39.6 US gpm)	240 l/min (63.4 US gpm)	350 l/min (92.5 US gpm)
Max. regulated flow	Line C	30 l/min (7.9 US gpm)	50 l/min (13.2 US gpm)	90 l/min (23.8 US gpm)	150 l/min (39.6 US gpm)	250 l/min (66 US gpm)
Max. regulated flow "SB"		15 l/min (4.0 US gpm)	25 l/min (6.6 US gpm)	45 l/min (11.9 US gpm)	75 l/min (19.8 US gpm)	125 l/min (33 US gpm)
Max. pressure		Aluminium body = 210 bar (3050 psi) Steel body = 350 bar (5100 psi)				
Fluid		mineral based oil				
Viscosity		from 10 to 200 cSt				
Max. level of contamination		18/16/13 ISO4406				
Fluid temperature		with NBR seals from -20°C (-4°F) to 80°C (176°F)				
Environmental temperature for working conditions		from -40°C (-40°F) to 100°C (212°F)				
Weight	aluminium	1.07 kg (2.36 lb)	1.02 kg (2.25 lb)	2.22 kg (4.89 lb)	4.06 kg (8.95 lb)	4.49 kg (20.94 lb)
	steel	2.48 kg (5.47 lb)	2.43 kg (5.36 lb)	4.42 kg (9.74 lb)	8.49 kg (18.72 lb)	9.65 kg (21.27 lb)

NOTE - For different conditions, please contact Walvoil Sales Dpt.

*"SB" execution (sensibilized adjustment)

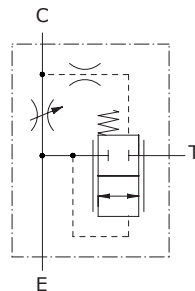

Dimensions

VPR/3/ET 38 - VPR/3/ET 12 - VPR/3/ET 34

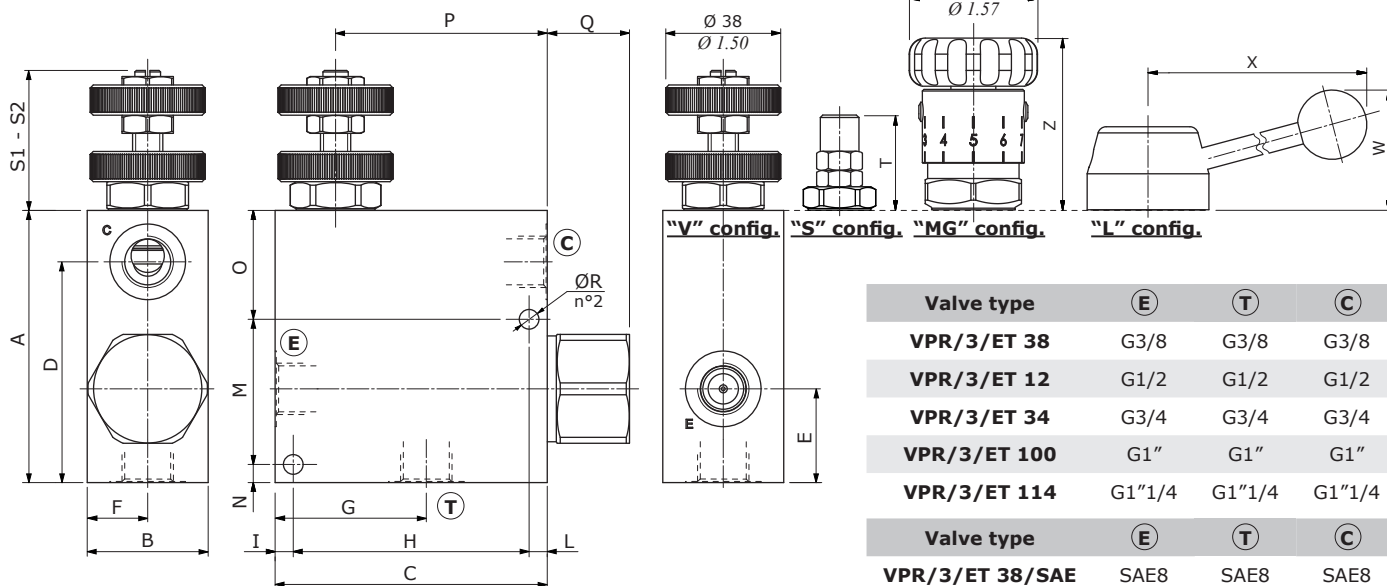

Valve type	ⓔ	Ⓣ	Ⓒ
VPR/3/ET 38	G3/8	G3/8	G3/8
VPR/3/ET 12	G1/2	G1/2	G1/2
VPR/3/ET 34	G3/4	G3/4	G3/4
VPR/3/ET 100	G1"	G1"	G1"
VPR/3/ET 114	G1"1/4	G1"1/4	G1"1/4

Valve type	ⓔ	Ⓣ	Ⓒ
VPR/3/ET 38/SAE	SAE8	SAE8	SAE8
VPR/3/ET 12/SAE	SAE10	SAE10	SAE10
VPR/3/ET 34/SAE	SAE12	SAE12	SAE12
VPR/3/ET 100/SAE	SAE16	SAE16	SAE16
VPR/3/ET 114/SAE	SAE20	SAE20	SAE20

VPR/3/ET 100 - VPR/3/ET 114

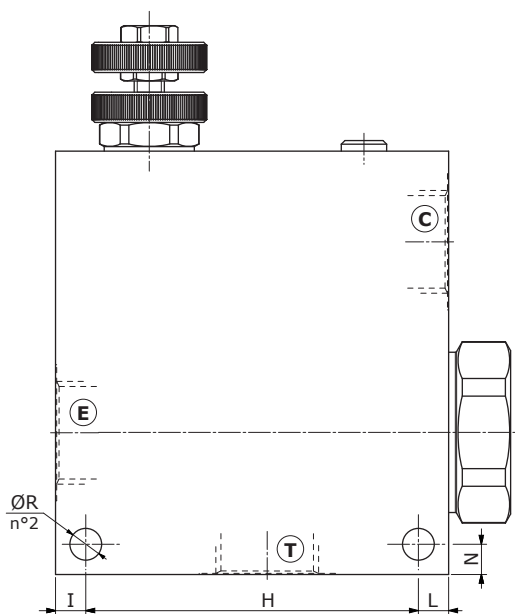

Dimensions are in mm-in

Valve type	A	B	C	D	E	F
VPR/3/ET 38	90-3.54	40-1.57	90-3.54	73-2.87	31-1.22	20-0.78
VPR/3/ET 38/SAE						
VPR/3/ET 12	90-3.54	40-1.57	90-3.54	73-2.87	31-1.22	20-0.78
VPR/3/ET 12/SAE						
VPR/3/ET 34	110-0.31	50-1.97	110-4.33	85-3.35	35-1.38	25-0.98
VPR/3/ET 34/SAE						
VPR/3/ET 100	140-5.51	Alum: 70-2.75 Steel: 65-2.56	130-5.11	110-4.33	47-1.85	Alum: 35-1.38 Steel: 32.5-1.38
VPR/3/ET 100/SAE						
VPR/3/ET 114	165-6.5	Alum: 70-2.75 Steel: 65-2.56	130-5.11	135-5.31	65-2.56	Alum: 35-1.38 Steel: 32.5-1.38
VPR/3/ET 114/SAE						

Valve type	G	H	I - L	M	N	O	P
VPR/3/ET 38	47.5-1.87	78-3.07	6-0.24	48-1.89	6-0.236	36-1.42	70-2.75
VPR/3/ET 38/SAE							
VPR/3/ET 12	47.5-1.87	78-3.07	6-0.24	48-1.89	6-0.236	36-1.42	70-2.75
VPR/3/ET 12/SAE							
VPR/3/ET 34	66-2.60	94-3.70	8-0.31	55.5-2.18	8-0.315	46.5-1.83	82-3.23
VPR/3/ET 34/SAE							
VPR/3/ET 100	70-2.75	110-4.33	10-0.39	-	10-0.394	-	99-3.90
VPR/3/ET 100/SAE							
VPR/3/ET 114	35-1.38	110-4.33	10-0.39	-	10-0.394	-	99-3.90
VPR/3/ET 114/SAE							

Valve type	Q	ØR	S1	S2*	T	W	X	Z
VPR/3/ET 38	27.2-1.07	6.5-0.25	46.3-1.82	52.6-2.07	38.5-1.51	47.6-1.87	101.3-3.99	53.3-2.10
VPR/3/ET 38/SAE								
VPR/3/ET 12	27.2-1.07	6.5-0.25	46.3-1.82	53.1-2.09	38.5-1.51	47.6-1.87	101.3-3.99	53.3-2.10
VPR/3/ET 12/SAE								
VPR/3/ET 34	34.5-1.36	8.5-0.33	41.5-1.73	50.5-1.99	38.5-1.51	50.1-1.97	103.6-4.08	56.5-2.22
VPR/3/ET 34/SAE								
VPR/3/ET 100	20.5-0.81	10.5-0.41	41.5-1.73	50.5-1.99	38.5-1.51	50.1-1.97	103.6-4.08	56.5-2.22
VPR/3/ET 100/SAE								
VPR/3/ET 114	20.5-0.81	10.5-0.41	52-2.05	-	41.5-1.63	50.5-1.99	107.3-4.22	56.5-2.22
VPR/3/ET 114/SAE								

Flow control valves

Flow control pressure compensated valves

VPR/3/ET

Ordering codes and description composition

Port size
VPR/3/ET 38/V
1

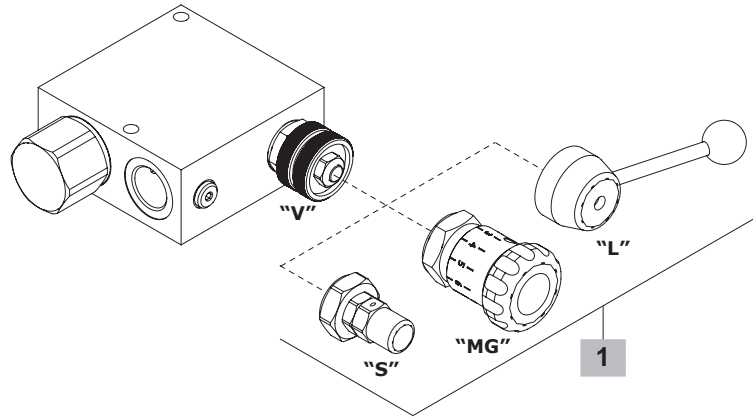

VPR/3/ET complete valves

Adjustment kit type "V" (handwheel)

TYPE	CODE	DESCRIPTION
VPR/3/ET 38/V	1620021100	Aluminium body, 3/8 ports
VPR/3/ET 12/V	1620031100	Aluminium body, 1/2 ports
VPR/3/ET 34/V	1620041100	Aluminium body, 3/4 ports
VPR/3/ET 100/V	1620051100	Aluminium body, 1" ports
VPR/3/ET 114/V	1620061100	Aluminium body, 1" 1/4 ports
VPR/3/ET 38/V/ac	1620022100	Steel body, 3/8 ports
VPR/3/ET 12/V/ac	1620032100	Steel body, 1/2 ports
VPR/3/ET 34/V/ac	1620042100	Steel body, 3/4 ports
VPR/3/ET 100/V/ac	1620052101	Steel body, 1" ports
VPR/3/ET 114/V/ac	1620062101	Steel body, 1" 1/4 ports
VPR/3/ET 38/V/SAE	1620021200	Aluminium body, SAE8 ports
VPR/3/ET 12/V/SAE	1620031200	Aluminium body, SAE10 ports
VPR/3/ET 34/V/SAE	1620041200	Aluminium body, SAE12 ports
VPR/3/ET 100/V/SAE	1620051200	Aluminium body, SAE16 ports
VPR/3/ET 114/V/SAE	1620061200	Aluminium body, SAE20 ports

Adjustment kit type "MG" (handknob)

VPR/3/ET 38/MG	1620021101	Aluminium body, 3/8 ports
VPR/3/ET 12/MG	1620031101	Aluminium body, 1/2 ports
VPR/3/ET 34/MG	1620041101	Aluminium body, 3/4 ports
VPR/3/ET 100/MG	1620051101	Aluminium body, 1" ports
VPR/3/ET 114/MG	1620061101	Aluminium body, 1" 1/4 ports

Adjustment kit type "L" (lever)

VPR/3/ET 38/L	1620021102	Aluminium body, 3/8 ports
VPR/3/ET 12/L	1620031102	Aluminium body, 1/2 ports
VPR/3/ET 34/L	1620041102	Aluminium body, 3/4 ports
VPR/3/ET 100/L	1620051102	Aluminium body, 1" ports
VPR/3/ET 114/L	1620061102	Aluminium body, 1" 1/4 ports
VPR/3/ET 38/L/SAE	1620021201	Aluminium body, SAE8 ports
VPR/3/ET 34/L/SAE	1620042200	Aluminium body, SAE12 ports

For other steel body configurations, SAE thread and configurations with FPM (Viton) seals, please contact our Sales Dpt.

1 Adjustment kit

TYPE	CODE	DESCRIPTION
For VPR/3/ET 38 valve		
V.SB	5KT6200200	"V" handwheel type in "SB" configuration (sensibilized adjustment)
V	5KT6130200	"V" handwheel type
MG	5KT6200202	"MG" handknob type
S	5KT6200211	"S" screw type
For VPR/3/ET 12 valve		
V.SB	5KT6130301	"V" handwheel type in "SB" configuration (sensibilized adjustment)
V	5KT6130200	"V" handwheel type
MG	5KT6200202	"MG" handknob type
S	5KT6200211	"S" screw type
For VPR/3/ET 34 and VPR/2/ET 100 valves		
V	5KT6130401	"V" handwheel type
MG	5KT6200400	"MG" handknob type
S	5KT6130404	"S" screw type
V.SB	5KT6130402	"V" handwheel type in "SB" configuration (sensibilized adjustment)
For VPR/3/ET 114 valve		
V	5KT6340603	"V" handwheel type
MG	5KT6200605	"MG" handknob type
S	5KT6200604	"S" screw type

Rating diagrams

VPR/3/ET 38 compensation diagram E-> C

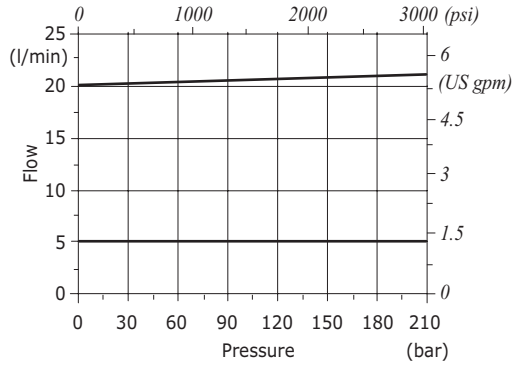

VPR/3/ET 12 compensation diagram E-> C

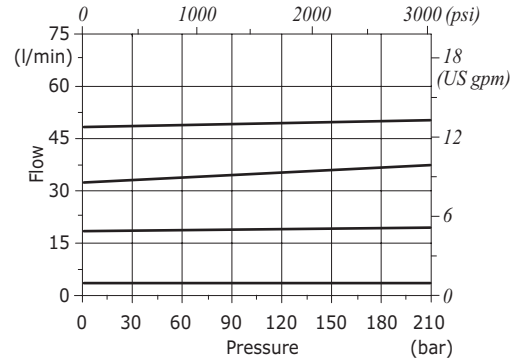

VPR/3/ET 34 compensation diagram E-> C

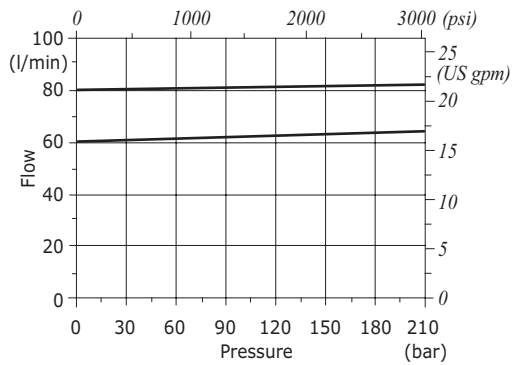

VPR/3/ET 100 compensation diagram E-> C

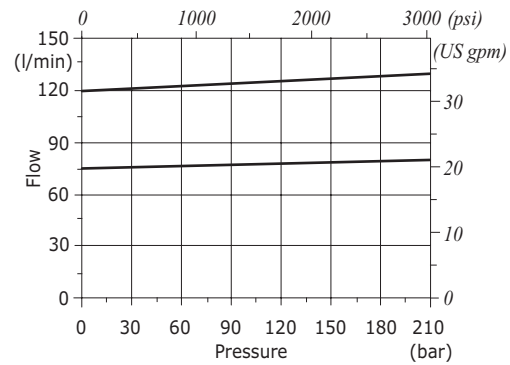

VPR/3/ET 114 compensation diagram E-> C

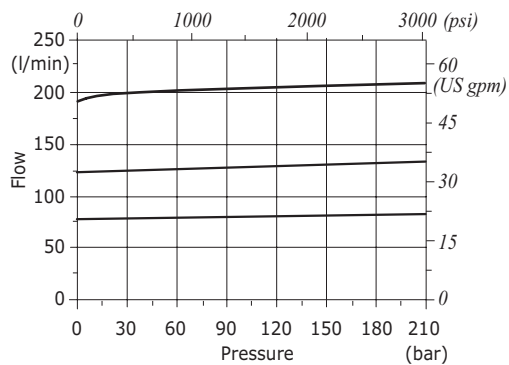



Type VPR/3/ET/RL flow control pressure compensated valves

- 3 ways
- With reverse free - flow check

Technical specifications and diagrams are measured with mineral oil of 46 cSt viscosity at 40°C (104°F) temperature.

		VPR/3/ET/RL 38	VPR/3/ET/RL 12	VPR/3/ET/RL 34
Max. inlet flow	Line E	50 l/min (13.2 US gpm)	90 l/min (23.8 US gpm)	150 l/min (39.6 US gpm)
Max. regulated flow	Line C	30 l/min (7.9 US gpm)	50 l/min (13.2 US gpm)	90 l/min (23.8 US gpm)
Max. regulated flow "SB"		15 l/min (4.0 US gpm)	25 l/min (6.6 US gpm)	45 l/min (11.9 US gpm)
Max. pressure		Aluminium body = 210 bar (3050 psi) Steel body = 350 bar (5100 psi)		
Fluid		mineral based oil		
Viscosity		from 10 to 200 cSt		
Max. level of contamination		18/16/13 ISO4406		
Fluid temperature		with NBR seals from -20°C (-4°F) to 80°C (176°F)		
Environmental temperature for working conditions		from -40°C (-40°F) to 100°C (212°F)		
Weight	aluminium	1.30 kg (2.86 lb)	1.25 kg (2.75 lb)	2.75 kg (6.06 lb)
	steel	2.86 kg (6.3 lb)	2.72 kg (6 lb)	5.95 kg (13,12 lb)

NOTE - For different conditions, please contact Walvoil Sales Dpt.

*"SB" execution (sensibilized adjustment)

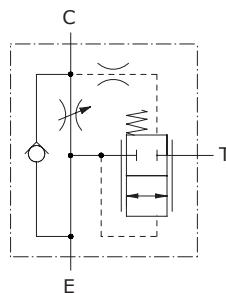

Dimensions

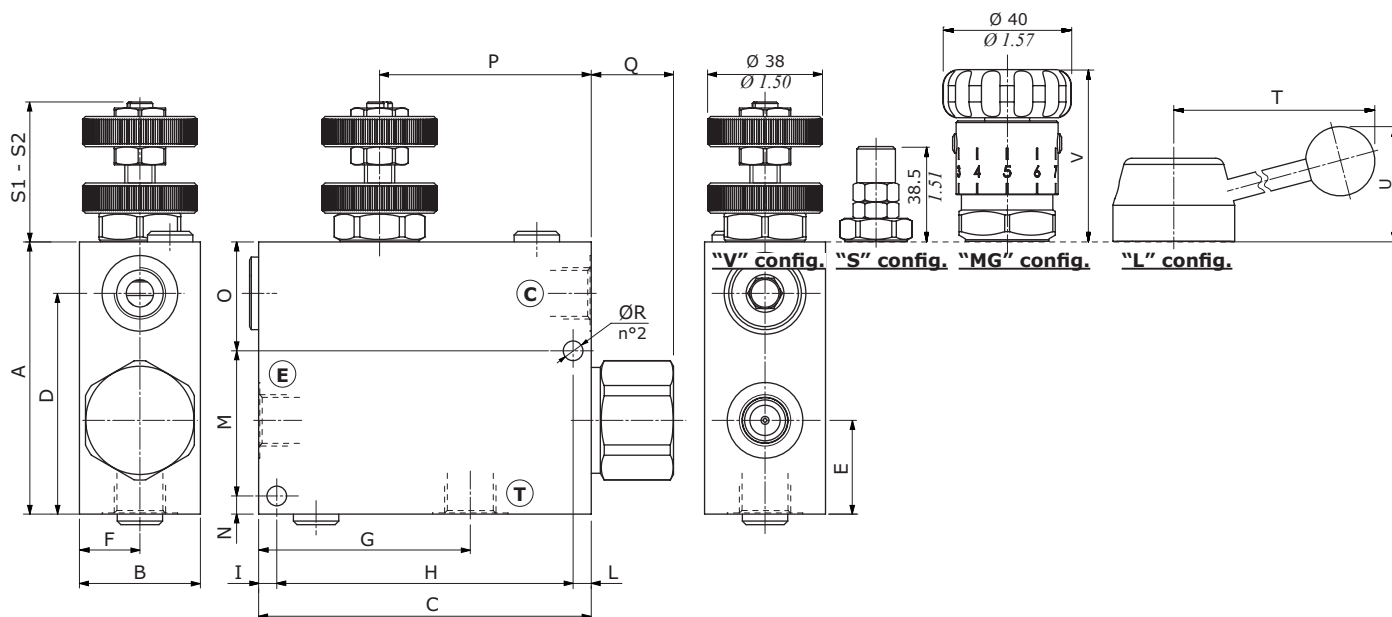

Valve type	(E)	(T)	(C)
VPR/3/ET/RL 38	G3/8	G3/8	G3/8
VPR/3/ET/RL 12	G1/2	G1/2	G1/2
VPR/3/ET/RL 34	G3/4	G3/4	G3/4

Dimensions are in mm-in

Valve type	A	B	C	D	E	F	G	H	I - L	M	N	O	P
VPR/3/ET/RL 38	90-3.54	40-1.57	110-0.43	17-0.24	31-1.22	20-0.78	70-2.75	98-3.86	6-0.236	48-1.89	6-0.236	36-0.24	70-2.75
VPR/3/ET/RL 12	90-3.54	40-1.57	110-0.43	17-0.24	31-1.22	20-0.78	70-2.75	98-3.86	6-0.236	48-1.89	6-0.236	36-0.24	70-2.75
VPR/3/ET/RL 34	120-4.72	50-1.97	138-5.43	25-0.98	35-1.38	25-0.98	94-3.7	122-4.80	8-0.315	55.5-2.18	8-0.315	56.5-0.24	81.5-3.21

Valve type	Q	ØR	S1	S2*	T	U	V
VPR/3/ET/RL 38	27.2-1.07	6.5-0.256	46.3-1.82	52.6-2.07	101.3-3.99	47.6-1.87	53.3-2.10
VPR/3/ET/RL 12	27.2-1.07	6.5-0.256	46.3-1.82	53.1-2.09	101.3-3.99	47.6-1.87	53.3-2.10
VPR/3/ET/RL 34	34.5-1.36	8.5-0.335	41.5-1.73	50.5-1.99	103.6-4.08	50.1-1.97	56.5-2.22

Flow control valves

Flow control pressure compensated valves

VPR/3/ET/RL

Ordering codes and description composition

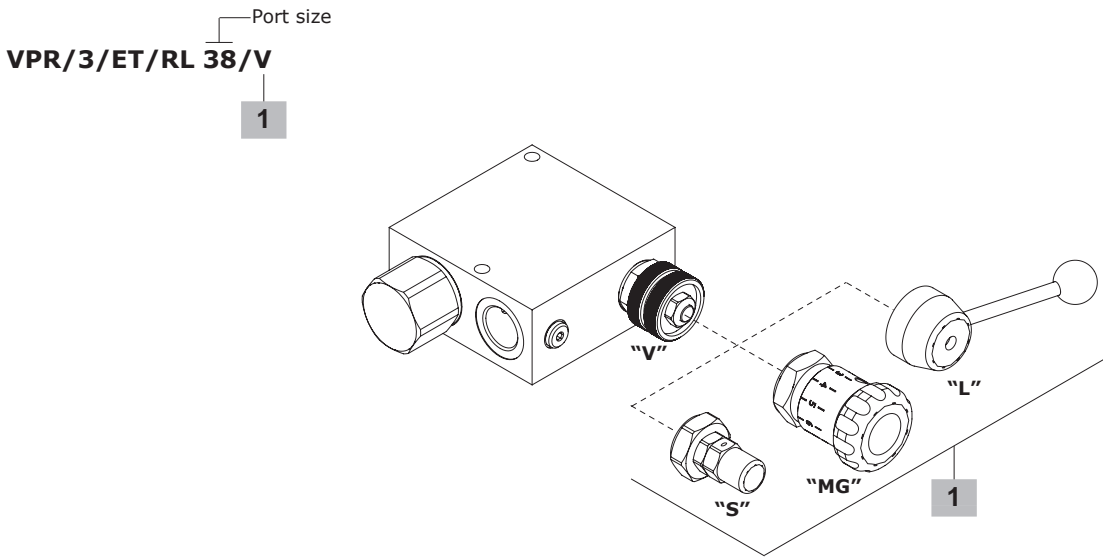

VPR/3/ET/RL complete valves

TYPE	CODE	DESCRIPTION
Adjustment kit type "V" (handwheel)		
VPR/3/ET/RL 38/V	1621021100	Aluminium body, 3/8 ports
VPR/3/ET/RL 12/V	1621031100	Aluminium body, 1/2 ports
VPR/3/ET/RL 34/V	1621041100	Aluminium body, 3/4 ports
VPR/3/ET/RL 38/V/ac	1621022100	Steel body, 3/8 ports
VPR/3/ET/RL 12/V/ac	1621032101	Steel bod , 1/2 ports
VPR/3/ET/RL 34/V/ac	1621042100	Steel body, 3/4 ports
Adjustment kit type "MG" (handknob)		
VPR/3/ET/RL 38/MG	1621021101	Aluminium body, 3/8 ports
VPR/3/ET/RL 12/MG	1621031101	Aluminium body, 1/2 ports
VPR/3/ET/RL 34/MG	1621041101	Aluminium body, 3/4 ports
Adjustment kit type "L" (lever)		
VPR/3/ET/RL 38/L	1621021102	Aluminium body, 3/8 ports
VPR/3/ET/RL 12/L	1621031102	Aluminium body, 1/2 ports
VPR/3/ET/RL 34/L	1621041102	Aluminium body, 3/4 ports

For other steel body configurations, SAE thread and configurations with FPM (Viton) seals, please contact our Sales Dpt.

1 Adjustment kit

TYPE	CODE	DESCRIPTION
For VPR/3/ET 38 valve		
V.SB	5KT6200200	"V" handwheel type in "SB" configuration (sensibilized adjustment)
V	5KT6130200	"V" handwheel type
MG	5KT6200202	"MG" handknob type
S	5KT6200211	"S" screw type
For VPR/3/ET 12 valve		
V.SB	5KT6130301	"V" handwheel type in "SB" configuration (sensibilized adjustment)
V	5KT6130200	"V" handwheel type
MG	5KT6200202	"MG" handknob type
S	5KT6200211	"S" screw type
For VPR/3/ET 34 valve		
V	5KT6130401	"V" handwheel type
MG	5KT6200400	"MG" handknob type
S	5KT6130404	"S" screw type
V.SB	5KT6130402	"V" handwheel type in "SB" configuration (sensibilized adjustment)

Rating diagrams

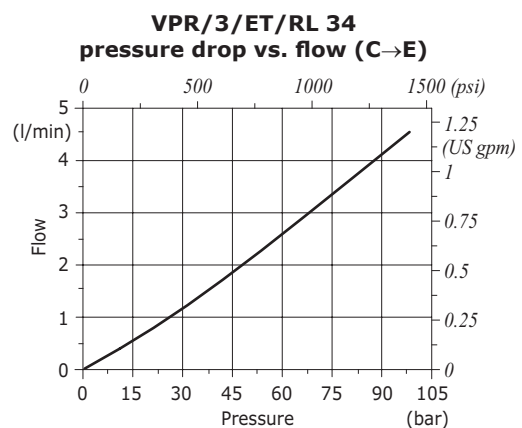
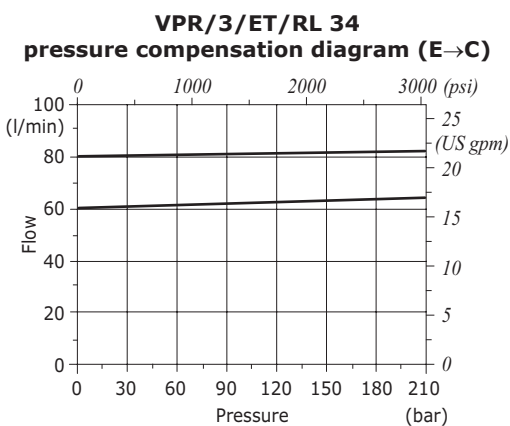
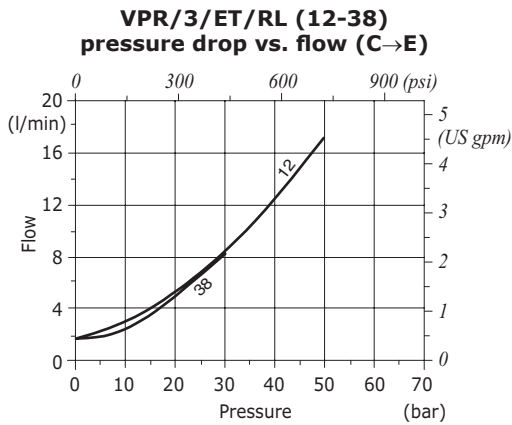
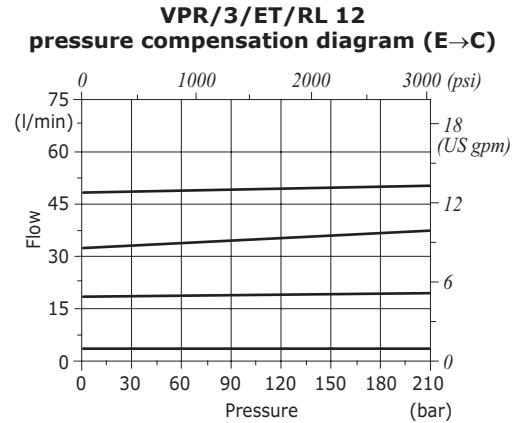
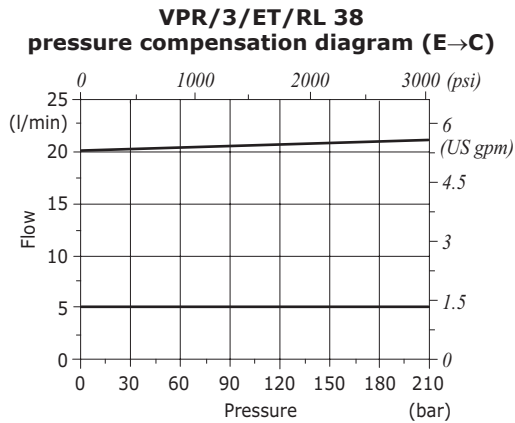

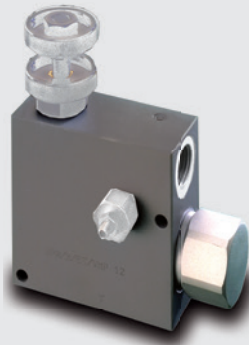

Type VPR/3/ET/VMP flow control pressure compensated valves

- 3 ways
- With pressure relief valve

Technical specifications and diagrams are measured with mineral oil of 46 cSt viscosity at 40°C (104°F) temperature.

		VPR/3/ET/ VMP 38	VPR/3/ET/ VMP 12	VPR/3/ET/ VMP 34	VPR/3/ET/ VMP 100	VPR/3/ET/ VMP 114
Max. inlet flow	Line E	50 l/min (13.2 US gpm)	90 l/min (23.8 US gpm)	150 l/min (39.6 US gpm)	240 l/min (63.4 US gpm)	350 l/min (92.5 US gpm)
Max. regulated flow	Line C	30 l/min (7.9 US gpm)	50 l/min (13.2 US gpm)	90 l/min (23.8 US gpm)	150 l/min (40 US gpm)	250 l/min (66 US gpm)
Max. regulated flow "SB" *		15 l/min (4.0 US gpm)	25 l/min (6.6 US gpm)	45 l/min (11.9 US gpm)	75 l/min (19.8 US gpm)	125 l/min (33 US gpm)
Max. pressure		Aluminium body = 210 bar (3050 psi) Steel body = 350 bar (5100 psi)				
Fluid		mineral based oil				
Viscosity		from 10 to 200 cSt				
Max. level of contamination		18/16/13 ISO4406				
Fluid temperature		with NBR seals from -20°C (-4°F) to 80°C (176°F)				
Environmental temperature for working conditions		from -40°C (-40°F) to 100°C (212°F)				
Weight	aluminium	1.10 kg (2.42 lb)	1.20 kg (2.64 lb)	2.10 kg (4.62 lb)	4.10 kg (9.04 lb)	4.66 kg (10.27 lb)
	steel	2.31 kg (5.09 lb)	2.42 kg (5.33 lb)	4.37 kg (9.63 lb)	8.27 kg (18.23 lb)	9.43 kg (20.79 lb)

NOTE - For different conditions, please contact Walvoil Sales Dpt.

***"SB"** execution (sensitized adjustment)

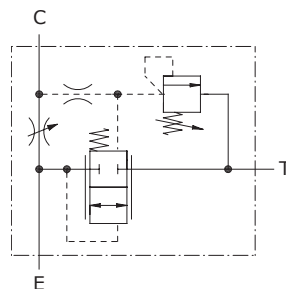

Dimensions

VPR/3/ET/VMP 38 - VPR/3/ET/VMP 12 - VPR/3/ET/VMP 34

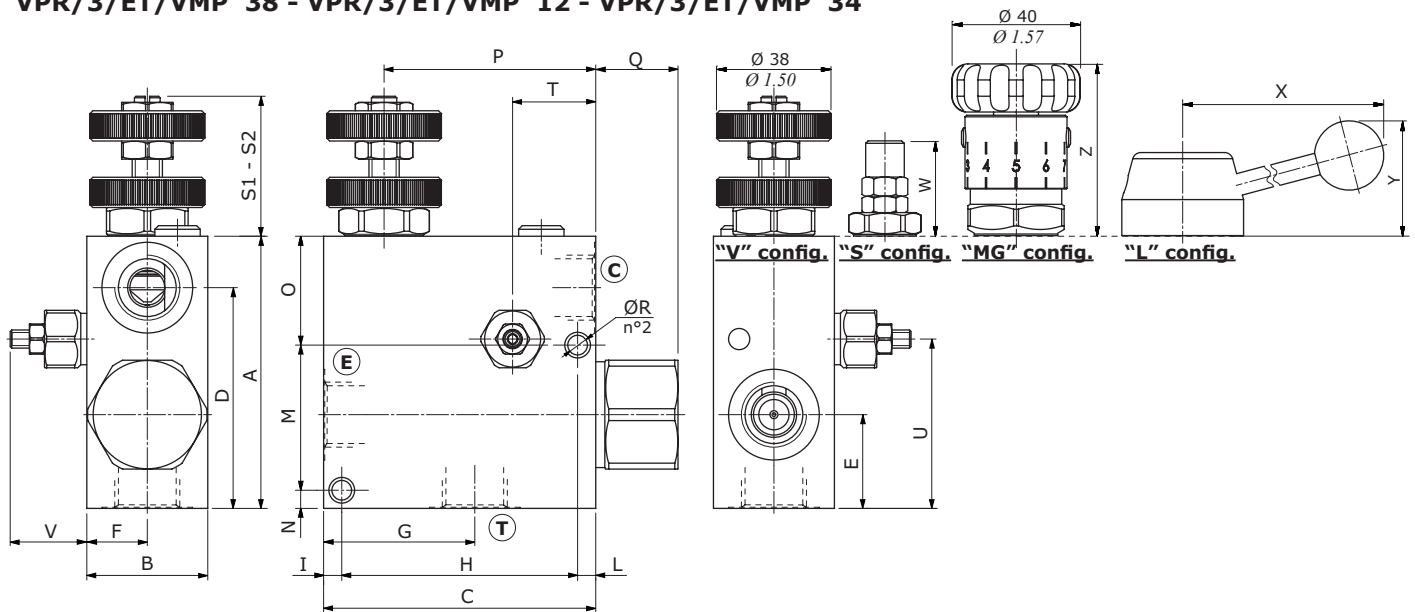

Dimensions are in mm-in

VPR/3/ET/VMP 100 VPR/3/ET/VMP 114

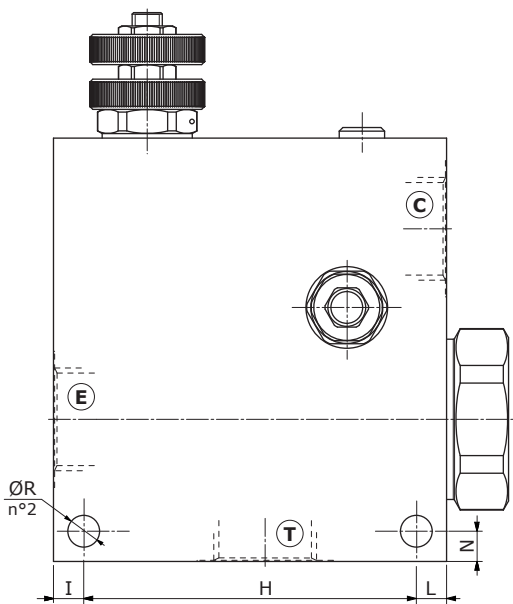

Valve type	A	B	C	D	E	G
VPR/3/ET/VMP 38 VPR/3/ET/VMP 38/SAE	90-3.54	40-1.57	90-3.54	73-2.87	31-1.22	50-1.97
VPR/3/ET/VMP 12 VPR/3/ET/VMP 12/SAE	90-3.54	40-1.57	90-3.54	73-2.87	31-1.22	50-1.97
VPR/3/ET/VMP 34 VPR/3/ET/VMP 34/SAE	110-0.31	50-1.97	110-4.33	85-3.35	35-1.38	66-2.60
VPR/3/ET/VMP 100	140-5.51	65-2.56	130-5.11	110-4.33	47-1.85	70-2.75
VPR/3/ET/VMP 114	165-6.5	Alum:70-2.75 Steel:65-2.56	130-5.11	135-5.31	65-2.56	70-2.75

Valve type	F	H	I-L	M	N	O
VPR/3/ET/VMP 38 VPR/3/ET/VMP 38/SAE	20-0.78	78-3.07	6-0.236	48-1.89	6-0.236	36-1.42
VPR/3/ET/VMP 12 VPR/3/ET/VMP 12/SAE	20-0.78	78-3.07	6-0.236	48-1.89	6-0.236	36-1.42
VPR/3/ET/VMP 34 VPR/3/ET/VMP 34/SAE	25-0.98	94-3.70	8-0.31	55.5-2.18	8-0.31	46.5-1.83
VPR/3/ET/VMP 100	32.5-1.28	110-4.33	10-0.394	-	10-0.394	-
VPR/3/ET/VMP 114	Alum:35-1.38 Steel:32.5-1.28	110-4.33	10-0.394	-	10-0.394	-

Valve type	P	Q	ØR	S1	S2	T
VPR/3/ET/VMP 38 VPR/3/ET/VMP 38/SAE	70-2.75	27.2-1.07	6.5-0.256	46.3-1.82	52.6-2.07	27.5-1.08
VPR/3/ET/VMP 12 VPR/3/ET/VMP 12/SAE	70-2.75	27.2-1.07	6.5-0.256	46.3-1.82	53.1-2.09	27.5-1.08
VPR/3/ET/VMP 34 VPR/3/ET/VMP 34/SAE	82-3.23	34.5-1.36	8.5-0.335	41.5-1.73	50.5-1.99	44-1.73
VPR/3/ET/VMP 100	99-3.90	20.5-0.81	10.5-0.413	41.5-1.73	50.5-1.99	33-0.12
VPR/3/ET/VMP 114	99-3.90	20.5-0.81	10.5-0.413	52-2.05	-	33-0.12

Valve type	E	T	C
VPR/3/ET/VMP 38	G3/8	G3/8	G3/8
VPR/3/ET/VMP 12	G1/2	G1/2	G1/2
VPR/3/ET/VMP 34	G3/4	G3/4	G3/4
VPR/3/ET/VMP 100	G1"	G1"	G1"
VPR/3/ET/VMP 114	G1"1/4	G1"1/4	G1"1/4

Valve type	U	V	W	X	Y	Z
VPR/3/ET/VMP 38 VPR/3/ET/VMP 38/SAE	56-2.20	27.2-1.07	38.5-1.51	101.3-3.99	47.6-1.87	53.3-2.10
VPR/3/ET/VMP 12 VPR/3/ET/VMP 12/SAE	56-2.20	27.2-1.07	38.5-1.51	101.3-3.99	47.6-1.87	53.3-2.10
VPR/3/ET/VMP 34 VPR/3/ET/VMP 34/SAE	63.5-2.50	27.2-1.07	38.5-1.51	103.6-4.08	50.1-1.97	56.5-2.22
VPR/3/ET/VMP 100	84-3.31	53-2.09	38.5-1.51	103.6-4.08	50.1-1.97	56.5-2.22
VPR/3/ET/VMP 114	98-3.86	43-1.69	41.5-1.73	107.3-4.22	50.5-1.99	56.5-2.22

Valve type	E	T	C
VPR/3/ET/VMP 38/SAE	SAE8	SAE8	SAE8
VPR/3/ET/VMP 12/SAE	SAE10	SAE10	SAE10
VPR/3/ET/VMP 34/SAE	SAE12	SAE12	SAE12

Flow control valves

Flow control pressure compensated valves

VPR/3/ET/VMP

Ordering codes and description composition

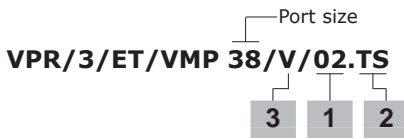

VPR/3/ET/VMP complete valves

Adjustment kit type "V" (handwheel)

TYPE: VPR/3/ET/VMP 38/V/02.TS	CODE: 1623021100
DESCRIPTION: alum. body, 3/8 ports, setting range 50-220 bar (725-3200 psi)	
TYPE: VPR/3/ET/VMP 12/V/02.TS	CODE: 1623031100
DESCRIPTION: alum. body, 1/2 ports, setting range 50-220 bar (725-3200 psi)	
TYPE: VPR/3/ET/VMP 34/V/02.TS	CODE: 1623041100
DESCRIPTION: alum. body, 3/4 ports, setting range 50-220 bar (725-3200 psi)	
TYPE: VPR/3/ET/VMP 100/V/02.TS	CODE: 1623051103
DESCRIPTION: alum. body, 1" ports, setting range 50-200 bar (725-2900 psi)	
TYPE: VPR/3/ET/VMP 114/V/02.TS	CODE: 1623061100
DESCRIPTION: alum. body, 1 1/4 ports, setting range 50-200 bar (725-2900 psi)	
TYPE: VPR/3/ET/VMP 38/V/02.TS/ac	CODE: 1623022100
DESCRIPTION: steel body, 3/8 ports, setting range 50-220 bar (725-3200 psi)	
TYPE: VPR/3/ET/VMP 12/V/02.TS/ac	CODE: 1623032100
DESCRIPTION: steel body, 1/2 ports, setting range 50-200 bar (725-2900 psi)	
TYPE: VPR/3/ET/VMP 34/V/03.TS/ac	CODE: 1623042102
DESCRIPTION: steel body, 3/4 ports, setting range 50-200 bar (725-2900 psi)	
TYPE: VPR/3/ET/VMP 100/V/03.TS/ac	CODE: 1623052104
DESCRIPTION: steel body, 1" ports, setting range 50-200 bar (725-2900 psi)	
TYPE: VPR/3/ET/VMP 114/V/03.TS/ac	CODE: 1623062100
DESCRIPTION: steel body, 1 1/4 ports, setting range 50-200 bar (725-2900 psi)	
TYPE: VPR/3/ET/VMP 38/V/02.TS/SAE	CODE: 1623021200
DESCRIPTION: alum. body, SAE8 ports, setting range 50-220 bar (725-3200 psi)	
TYPE: VPR/3/ET/VMP 12/V/02.TS/SAE	CODE: 1623031200
DESCRIPTION: alum. body, SAE10 ports, setting range 50-220 bar (725-3200 psi)	
TYPE: VPR/3/ET/VMP 34/V/02.TS/SAE	CODE: 1623041200
DESCRIPTION: alum. body, SAE12 ports, setting range 50-220 bar (725-3200 psi)	

Adjustment kit type "MG" (handknob)

TYPE: VPR/3/ET/VMP 38/MG/02.TS	CODE: 16230211001
DESCRIPTION: alum. body, 3/8 ports, setting range 50-220 bar (725-3200 psi)	
TYPE: VPR/3/ET/VMP 12/MG/02.TS	CODE: 1623031101
DESCRIPTION: alum. body, 1/2 ports, setting range 50-220 bar (725-3200 psi)	
TYPE: VPR/3/ET/VMP 34/MG/02.TS	CODE: 1623041101
DESCRIPTION: alum. body, 3/4 ports, setting range 50-220 bar (725-3200 psi)	
TYPE: VPR/3/ET/VMP 100/MG/02.TS	CODE: 1623051101
DESCRIPTION: alum. body, 1" ports, setting range 50-200 bar (725-2900 psi)	
TYPE: VPR/3/ET/VMP 114/MG/02.TS	CODE: 1623061101
DESCRIPTION: alum. body, 1 1/4 ports, setting range 50-200 bar (725-2900 psi)	
TYPE: VPR/3/ET/VMP 12/MG/02.TS/SAE	CODE: 1623031201
DESCRIPTION: alum. body, SAE10 ports, setting range 50-220 bar (725-3200 psi)	

Adjustment kit type "L" (lever)

TYPE: VPR/3/ET/VMP 38/L/02.TS	CODE: 1623021102
DESCRIPTION: alum. body, 3/8 ports, setting range 50-220 bar (725-3200 psi)	
TYPE: VPR/3/ET/VMP 12/L/02.TS	CODE: 1623031102
DESCRIPTION: alum. body, 1/2 ports, setting range 50-220 bar (725-3200 psi)	
TYPE: VPR/3/ET/VMP 34/L/02.TS	CODE: 1623041102
DESCRIPTION: alum. body, 3/4 ports, setting range 50-220 bar (725-3200 psi)	
TYPE: VPR/3/ET/VMP 100/L/02.TS	CODE: 1623051102
DESCRIPTION: alum. body, 1" ports, setting range 50-200 bar (725-2900 psi)	
TYPE: VPR/3/ET/VMP 114/L/02.TS	CODE: 1623061102
DESCRIPTION: alum. body, 1 1/4 ports, setting range 50-200 bar (725-2900 psi)	
TYPE: VPR/3/ET/VMP 38/L/02.TS/SAE	CODE: 1623021202
DESCRIPTION: alum. body, SAE8 ports, setting range 50-220 bar (725-3200 psi)	

For other steel body configurations, SAE thread and configurations with FPM (Viton) seals, please contact our Sales Dpt.

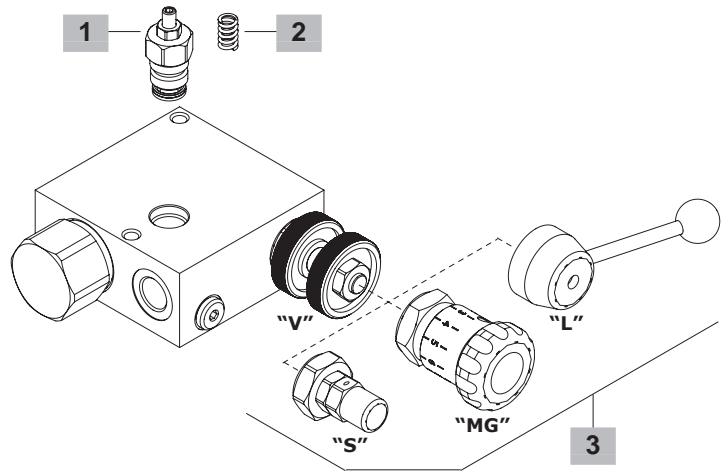

1 Pressure relief valve

TYPE	CODE	DESCRIPTION
For VPR/3/ET/VMP 38 and 12 + VPR/3/ET/VMP 34 aluminium body VMP 02/TS.S		
1100000101		Direct acting cartridge, setting range 50-220 bar (725-3200 psi)
For VPR/3/ET/VMP 34 steel body + VPR/3/ET/VMP 100 and 114 MC08A/0S2B		
0MC08002000		Direct acting cartridge, setting range 50-200 bar (725-2900 psi)

2 Pressure setting springs

TYPE	CODE	DESCRIPTION
For VPR/3/ET/VMP 38 and 12 + VPR/3/ET/VMP 34 aluminium body		
TV	3ML1081400	Setting range 5-80 bar (72.5-1150 psi)
TS	3ML1081401	Setting range 50-220 bar (725-3200 psi)
TR	3ML1081402	Setting range 180-350 bar (2600-5100 psi)
For VPR/3/ET/VMP 34 steel body + VPR/3/ET/VMP 100 and 114		
TV	3ML1092500	Setting range 5-50 bar (72.5-725 psi)
TS	3ML1092501	Setting range 50-200 bar (725-2900 psi)
TR	3ML1092502	Setting range 150-350 bar (2600-5100 psi)

3 Adjustment kit

TYPE	CODE	DESCRIPTION
For VPR/3/ET/VMP 38 valve		
V.SB	5KT6200200	"V" handwheel type in "SB" configuration (sensibilized adjustment)
V	5KT6130200	"V" handwheel type
MG	5KT6200202	"MG" handknob type
S	5KT6200211	"S" screw type
For VPR/3/ET/VMP 12 valve		
V.SB	5KT6130301	"V" handwheel type in "SB" configuration (sensibilized adjustment)
V	5KT6130200	"V" handwheel type
MG	5KT6200202	"MG" handknob type
S	5KT6200211	"S" screw type
For VPR/3/ET/VMP 34 and VPR/2/ET/VMP 100 valves		
V	5KT6130401	"V" handwheel type
MG	5KT6200400	"MG" handknob type
S	5KT6130404	"S" screw type
V.SB	5KT6130402	"V" handwheel type in "SB" configuration (sensibilized adjustment)
For VPR/3/ET/VMP 114 valve		
V	5KT6340603	"V" handwheel type
MG	5KT6200605	"MG" handknob type
S	5KT6200604	"S" screw type

Rating diagrams

VPR/3/ET/VMP 38 pressure compensation diagram (E→C)

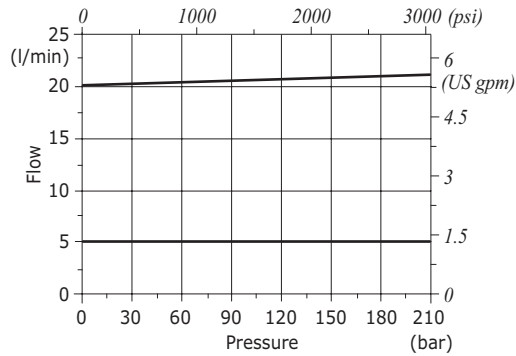

VPR/3/ET/VMP 12 pressure compensation diagram (E→C)

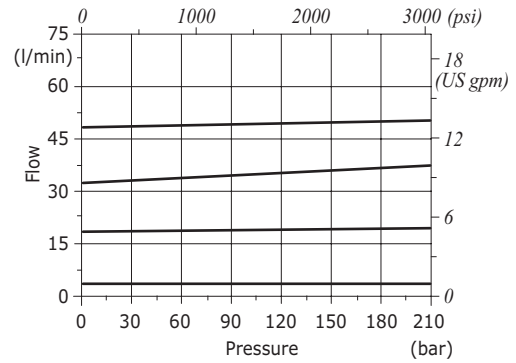

VPR/3/ET/VMP 34 pressure compensation diagram (E→C)

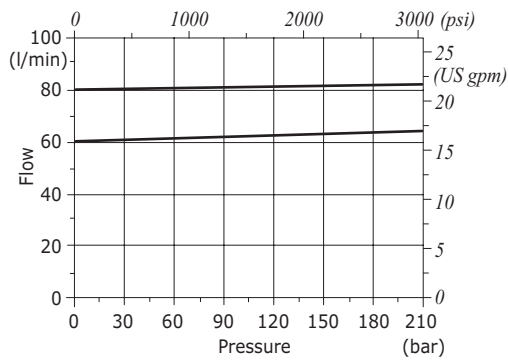

VPR/3/ET/VMP 100 pressure compensation diagram (E→C)

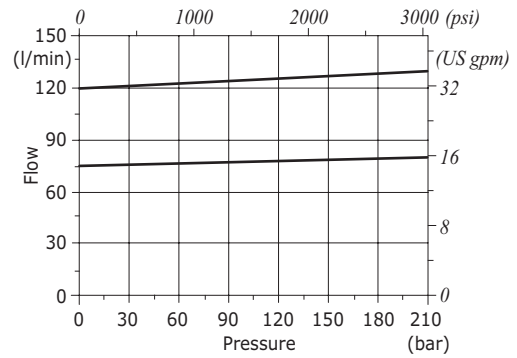

VPR/3/ET/VMP 114 pressure compensation diagram (E→C)

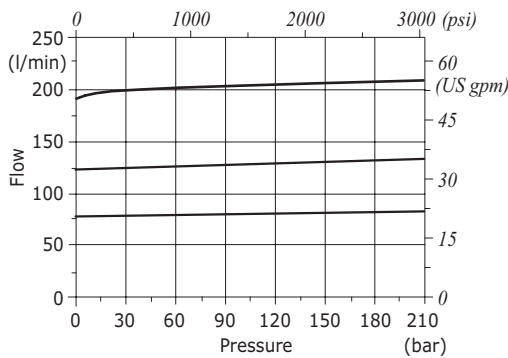



Type VPR/3/ET/RL/VMP flow control pressure compensated valves

- 3 ways
- With reverse free - flow check
- With pressure relief valve

Technical specifications and diagrams are measured with mineral oil of 46 cSt viscosity at 40°C (104°F) temperature.

		VPR/3/ET/RL/VMP 38	VPR/3/ET/RL/VMP 12	VPR/3/ET/RL/VMP 34
Max. inlet flow	Line C	50 l/min (13.2 US gpm)	90 l/min (23.8 US gpm)	150 l/min (39.6 US gpm)
Max. regulated flow	Line E	30 l/min (7.9 US gpm)	50 l/min (13.2 US gpm)	90 l/min (23.8 US gpm)
Max. regulated flow "SB"		15 l/min (4.0 US gpm)	25 l/min (6.6 US gpm)	45 l/min (11.9 US gpm)
Max. pressure		Aluminium body = 210 bar (3050 psi) Steel body = 350 bar (5100 psi)		
Fluid		mineral based oil		
Viscosity		from 10 to 200 cSt		
Max. level of contamination		18/16/13 ISO4406		
Fluid temperature		with NBR seals from -20°C (-4°F) to 80°C (176°F)		
Environmental temperature for working conditions		from -40°C (-40°F) to 100°C (212°F)		
Weight	aluminium	1.30 kg (2.86 lb)	1.25 kg (2.75 lb)	2.83 kg (6.24 lb)
	steel	2.78 kg (6.13 lb)	2.68 kg (5.9 lb)	6 kg (13,22 lb)

NOTE - For different conditions, please contact Walvoil Sales Dpt.

*"SB" execution (sensibilized adjustment)

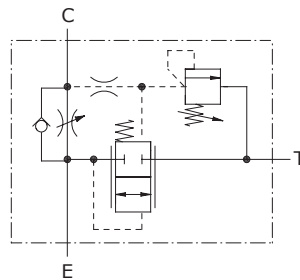

Dimensions

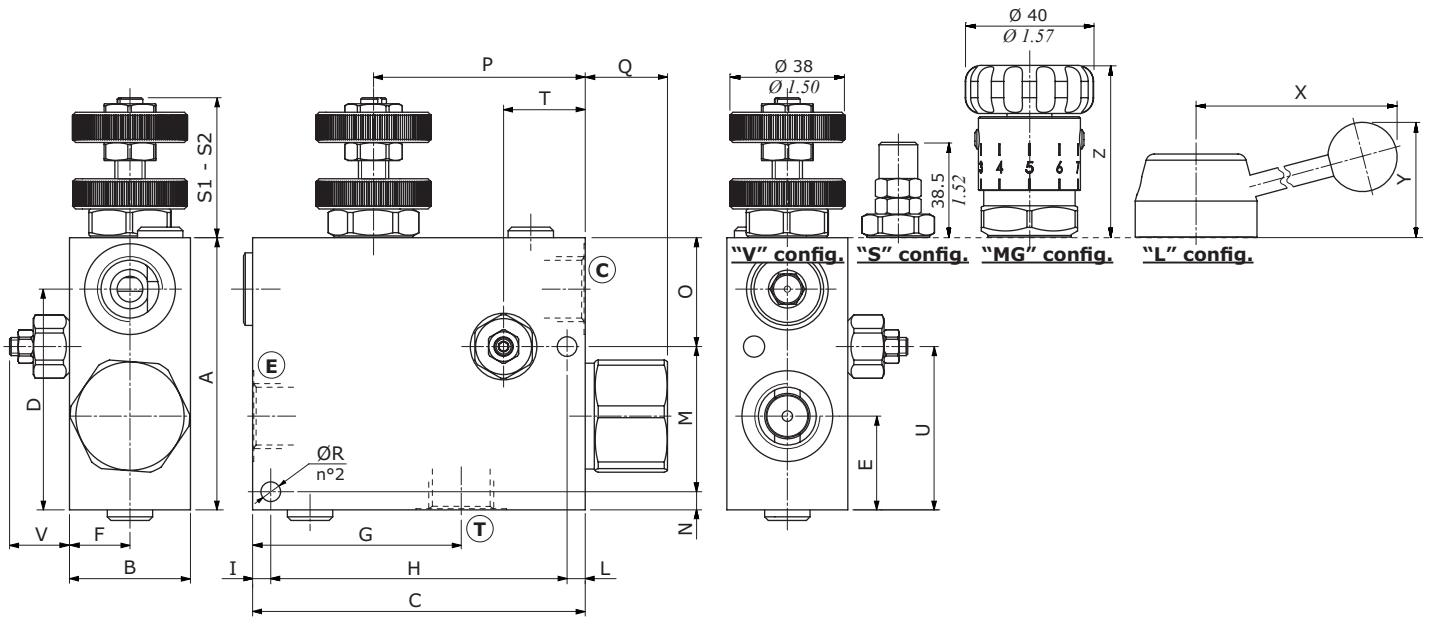

Valve type	Ⓔ	Ⓓ	Ⓒ
VPR/3/ET/RL/VMP 38	G3/8	G3/8	G3/8
VPR/3/ET/RL/VMP 12	G1/2	G1/2	G1/2
VPR/3/ET/RL/VMP 34	G3/4	G3/4	G3/4

Dimensions are in mm-in

Valve type	A	B	C	D	E	F	G	H	I - L	M	N	O
VPR/3/ET/RL/VMP 38	90-3.54	40-1.57	110-4.33	73-2.87	31-1.22	20-0.78	70-2.75	98-3.86	6-0.236	48-1.89	6-0.24	36-1.42
VPR/3/ET/RL/VMP 12	90-3.54	40-1.57	110-4.33	73-2.87	31-1.22	20-0.78	69-2.72	98-3.86	6-0.236	48-1.89	6-0.24	36-1.42
VPR/3/ET/RL/VMP 34	120-4.72	50-1.97	138-5.43	95-3.74	35-1.38	25-0.98	94-3.70	122-4.80	8-0.315	55.5-2.18	8-0.315	56.5-2.22

Valve type	P	Q	ØR	S1	S2	U	V	X	Y	Z
VPR/3/ET/RL/VMP 38	70-2.76	27.2-1.07	6.5-0.25	46.3-1.82	52.6-2.07	54-2.13	29.5-1.16	101.3-3.99	47.6-1.87	53.3-2.10
VPR/3/ET/RL/VMP 12	70-2.76	27.2-1.07	6.5-0.25	46.3-1.82	53.1-2.09	54-2.13	29.5-1.16	101.3-3.99	47.6-1.87	53.3-2.10
VPR/3/ET/RL/VMP 34	81.5-3.21	34.5-1.36	8.5-0.33	41.5-1.73	50.5-1.99	65-2.56	29.5-1.16	103.6-4.08	50.1-1.97	56.5-2.22

Flow control valves

Flow control pressure compensated valves

VPR/3/ET/RL/VMP

Ordering codes and description composition

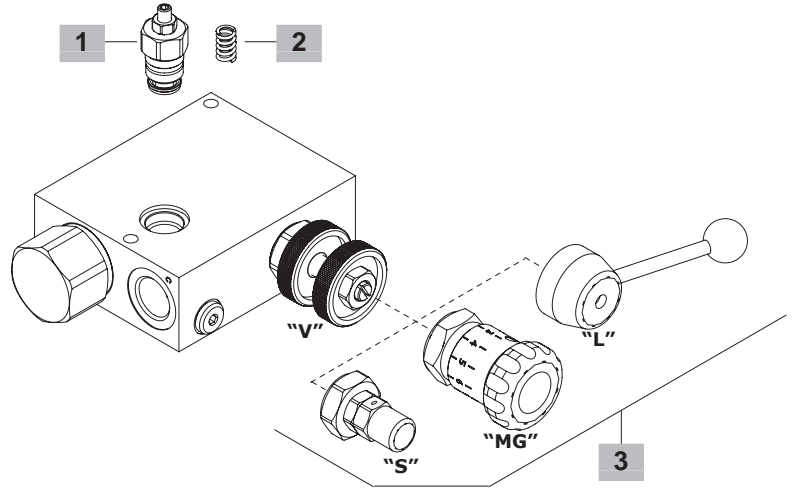

VPR/3/ET/RL/VMP complete valves

Adjustment kit type "V" (handwheel)

TYPE: **VPR/3/ET/RL/VMP 38/V/02.TS** CODE: 1623221101

DESCRIPTION: alum. body, 3/8 ports, setting range 50-220 bar (725-3200 psi)

TYPE: **VPR/3/ET/RL/VMP 12/V/02.TS** CODE: 1623231101

DESCRIPTION: alum. body, 1/2 ports, setting range 50-220 bar (725-3200 psi)

TYPE: **VPR/3/ET/RL/VMP 34/V/02.TS** CODE: 1623241101

DESCRIPTION: alum. body, 3/4 ports, setting range 50-220 bar (725-3200 psi)

TYPE: **VPR/3/ET/RL/VMP 38/V/02.TS/ac** CODE: 1623222100

DESCRIPTION: steel body, 3/8 ports, setting range 50-220 bar (725-3200 psi)

TYPE: **VPR/3/ET/RL/VMP 12/V/02.TS/ac** CODE: 1623232100

DESCRIPTION: steel body, 1/2 ports, setting range 50-220 bar (725-3200 psi)

TYPE: **VPR/3/ET/RL/VMP 34/V/02.TS/ac** CODE: 1623242100

DESCRIPTION: steel body, 3/4 ports, setting range 50-220 bar (725-3200 psi)

Adjustment kit type "MG" (handknob)

TYPE: **VPR/3/ET/RL/VMP 38/MG/02.TS** CODE: 1623221103

DESCRIPTION: alum. body, 3/8 ports, setting range 50-220 bar (725-3200 psi)

TYPE: **VPR/3/ET/RL/VMP 12/MG/02.TS** CODE: 1623231103

DESCRIPTION: alum. body, 1/2 ports, setting range 50-220 bar (725-3200 psi)

TYPE: **VPR/3/ET/RL/VMP 34/MG/02.TS** CODE: 1623241102

DESCRIPTION: alum. body, 3/4 ports, setting range 50-220 bar (725-3200 psi)

Adjustment kit type "L" (lever)

TYPE: **VPR/3/ET/RL/VMP 38/L/02.TS** CODE: 1623221104

DESCRIPTION: alum. body, 3/8 ports, setting range 50-220 bar (725-3200 psi)

TYPE: **VPR/3/ET/RL/VMP 12/L/02.TS** CODE: 1623231100

DESCRIPTION: alum. body, 1/2 ports, setting range 50-220 bar (725-3200 psi)

TYPE: **VPR/3/ET/RL/VMP 34/L/02.TS** CODE: 1623241100

DESCRIPTION: alum. body, 3/4 ports, setting range 50-220 bar (725-3200 psi)

For other steel body configurations, SAE thread and configurations with FPM (Viton) seals, please contact our Sales Dpt.

1 Pressure relief valve

TYPE	CODE	DESCRIPTION
VMP 02/TS.S	1100000101	Direct acting cartridge, setting range 50-220 bar (725-3200 psi)

2 Pressure setting springs

TYPE	CODE	DESCRIPTION
TV	3ML1081400	Setting range 5-80 bar (72.5-1150 psi)
TS	3ML1081401	Setting range 50-220 bar (725-3200 psi)
TR	3ML1081402	Setting range 180-350 bar (2600-5100 psi)

3 Adjustment kit

TYPE	CODE	DESCRIPTION
For VPR/3/ET/RL/VMP 38 valve		
V.SB	5KT6200200	"V" handwheel type in "SB" configuration (sensibilized adjustment)
V	5KT6130200	"V" handwheel type
MG	5KT6200202	"MG" handknob type
S	5KT6200211	"S" screw type

For VPR/3/ET/RL/VMP 12 valve		
V.SB	5KT6130301	"V" handwheel type in "SB" configuration (sensibilized adjustment)
V	5KT6130200	"V" handwheel type
MG	5KT6200202	"MG" handknob type
S	5KT6200211	"S" screw type

For VPR/3/ET/RL/VMP 34		
V	5KT6130401	"V" handwheel type
MG	5KT6200400	"MG" handknob type
S	5KT6130404	"S" screw type
V.SB	5KT6130402	"V" handwheel type in "SB" configuration (sensibilized adjustment)

Rating diagrams

VPR/3/ET/RL/VMP 38 pressure compensation diagram (E→C)

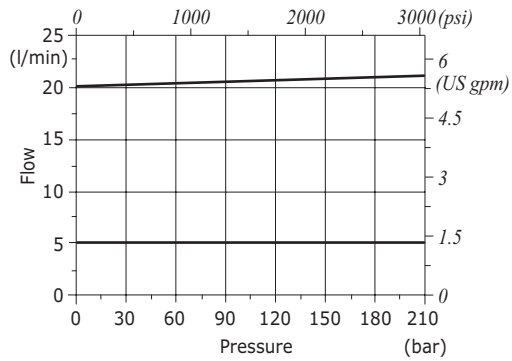

VPR/3/ET/RL/VMP 12 pressure compensation diagram (E→C)

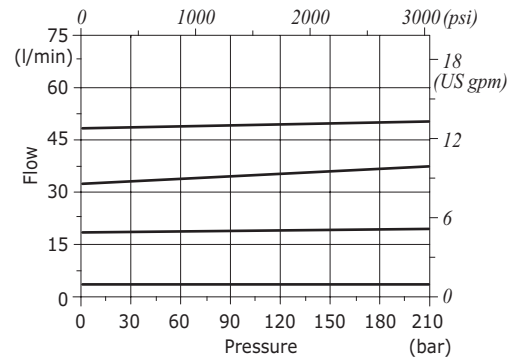

VPR/3/ET/RL/VMP 34 pressure compensation diagram (E→C)

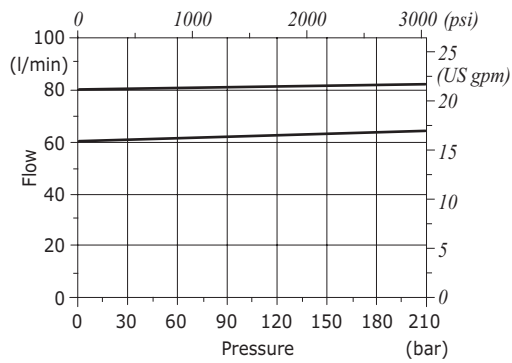



Type VPR/3/ET/VMP+VE flow control pressure compensated valves

- 3 ways
- Electric venting
- With pressure relief valve

Technical specifications and diagrams are measured with mineral oil of 46 cSt viscosity at 40°C (104°F) temperature.

		VPR/3/ET 38	VPR/3/ET 12	VPR/3/ET 34	VPR/3/ET 100
		+VMP+VE	+VMP+VE	+VMP+VE	+VMP+VE
Max. inlet flow	Line E	50 l/min (13.2 US gpm)	90 l/min (23.8 US gpm)	150 l/min (39.6 US gpm)	240 l/min (63.4 US gpm)
Max. regulated flow	Line C	30 l/min (7.9 US gpm)	50 l/min (13.2 US gpm)	90 l/min (23.8 US gpm)	150 l/min (39.6 US gpm)
Max. regulated flow "SB"		15 l/min (4.0 US gpm)	25 l/min (6.6 US gpm)	45 l/min (11.9 US gpm)	75 l/min (19.8 US gpm)
Max. pressure		Aluminium body = 210 bar (3050 psi) Steel body = 350 bar (5100 psi)			
Fluid		mineral based oil			
Viscosity		from 10 to 200 cSt			
Max. level of contamination		18/16/13 ISO4406			
Fluid temperature		with NBR seals from -20°C (-4°F) to 80°C (176°F)			
Environmental temperature for working conditions		from -40°C (-40°F) to 100°C (212°F)			
Weight	aluminium	1.45 kg (3.19 lb)	1.45 kg (3.19 lb)	2.61 kg (5.75 lb)	5.70 kg (12.56 lb)
	steel	3.08 kg (6.79 lb)	3.08 kg (6.79 lb)	5.54 kg (12.21 lb)	12.21 kg (26.92 lb)

NOTE - For different conditions, please contact Walvoil Sales Dpt.

*"SB" execution (sensibilized adjustment)

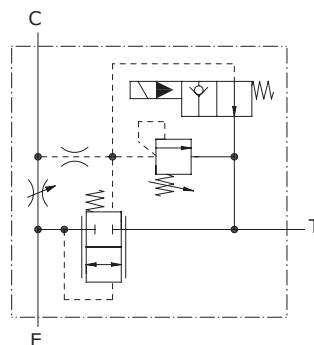

Dimensions

VPR/3/ET 38+VMP+VE - VPR/3/ET 12+VMP+VE - VPR/3/ET 34+VMP+VE

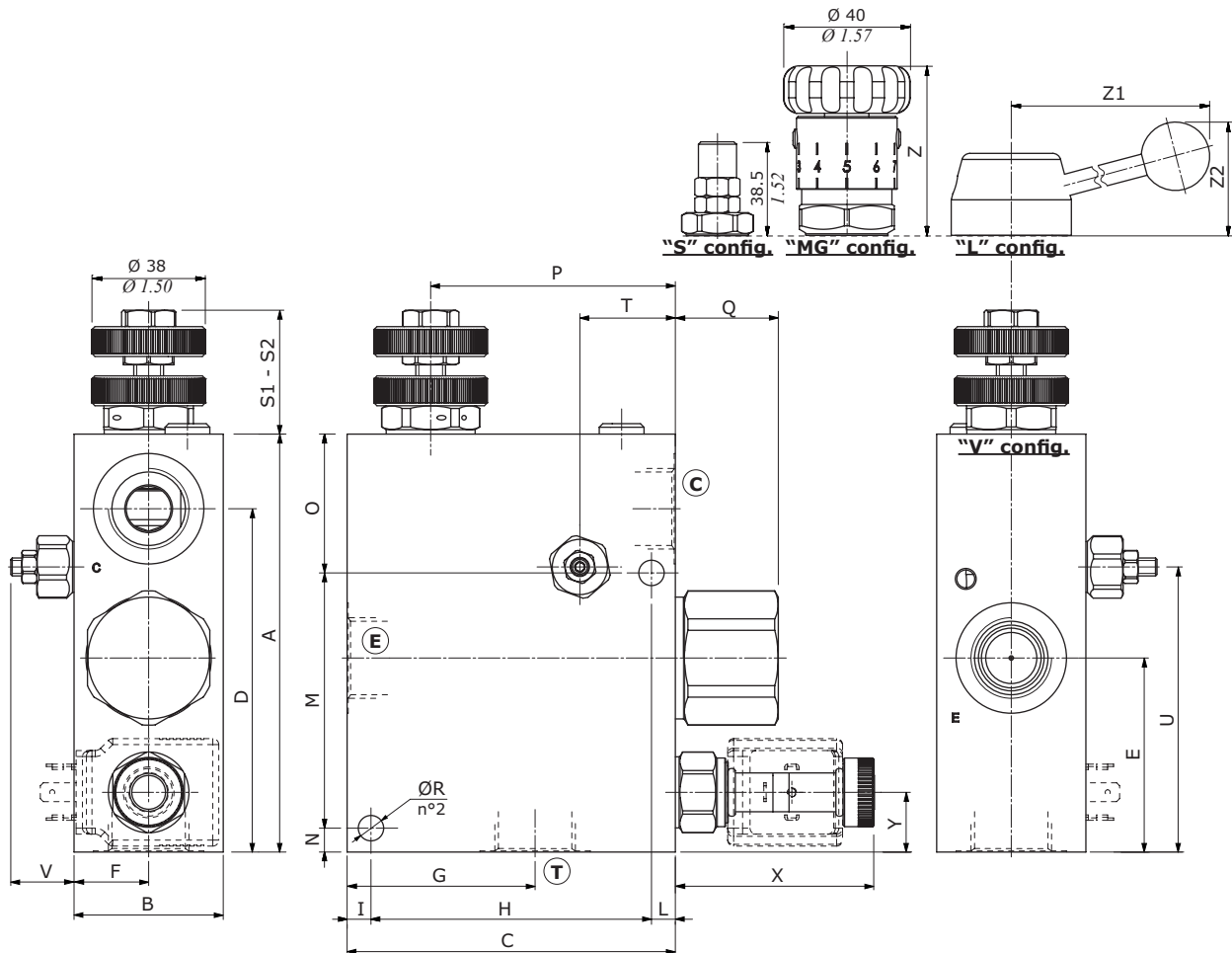

Valve type	Ⓔ	Ⓓ	Ⓒ
VPR/3/ET 38+VMP+VE	G3/8	G3/8	G3/8
VPR/3/ET 12+VMP+VE	G1/2	G1/2	G1/2
VPR/3/ET 34+VMP+VE	G3/4	G3/4	G3/4
VPR/3/ET 100+VMP+VE	G1"	G1"	G1"

Dimensions are in mm-in

Valve type	A	B	C	D	E	F	G	H	I - L	K	M	N	P
VPR/3/ET 38+VMP+VE	120-4.72	40-1.57	90-3.54	103-4.05	61-2.40	20-0.78	50-1.97	78-3.07	6-0.236	-	78-3.07	6-0.236	70-2.75
VPR/3/ET 12+VMP+VE	120-4.72	40-1.57	90-3.54	103-4.05	61-2.40	20-0.78	50-1.97	78-3.07	6-0.236	-	78-3.07	6-0.236	70-2.75
VPR/3/ET 34+VMP+VE	140-5.51	50-1.97	110-4.33	115-4.53	65-2.56	25-0.98	66-0.31	94-3.7	8-0.315	-	85.5-3.37	8-0.315	82-3.23
VPR/3/ET 100+VMP+VE	165-6.50	70-2.75	130-5.12	135-5.31	53-2.08	35-1.38	70-2.75	110-4.33	10-0.394	13-0.51	57-2.24	10-0.394	104-4.09

Valve type	Q	ØR	S1	S2	T	U	V	W	X (NA)	Y	Z	Z1	Z2
VPR/3/ET 38+VMP+VE	27.2-1.07	6.5-0.25	46.3-1.82	52.6-2.07	27-1.06	84-3.31	25-0.98	-	66.7-2.63	20-0.79	53.3-2.10	101.3-3.99	47.6-1.87
VPR/3/ET 12+VMP+VE	27.2-1.07	6.5-0.25	46.3-1.82	53.1-2.09	27-1.06	84-3.31	25-0.98	-	66.7-2.63	21.5-0.85	53.3-2.10	101.3-3.99	47.6-1.87
VPR/3/ET 34+VMP+VE	34.5-1.36	8.5-0.33	41.5-1.73	50.5-1.99	32-1.26	95.5-3.76	25-0.98	-	66.7-2.63	20-0.79	56.5-2.22	103.6-4.08	50.1-1.97
VPR/3/ET 100+VMP+VE	69.5-2.74	10.5-0.413	41.5-1.73	50.5-1.99	40-1.57	78-3.07	53-2.09	80-3.15	65.2-2.57	54.5-2.15	56.5-2.22	-	-

VPR/3/ET 100+VMP+VE

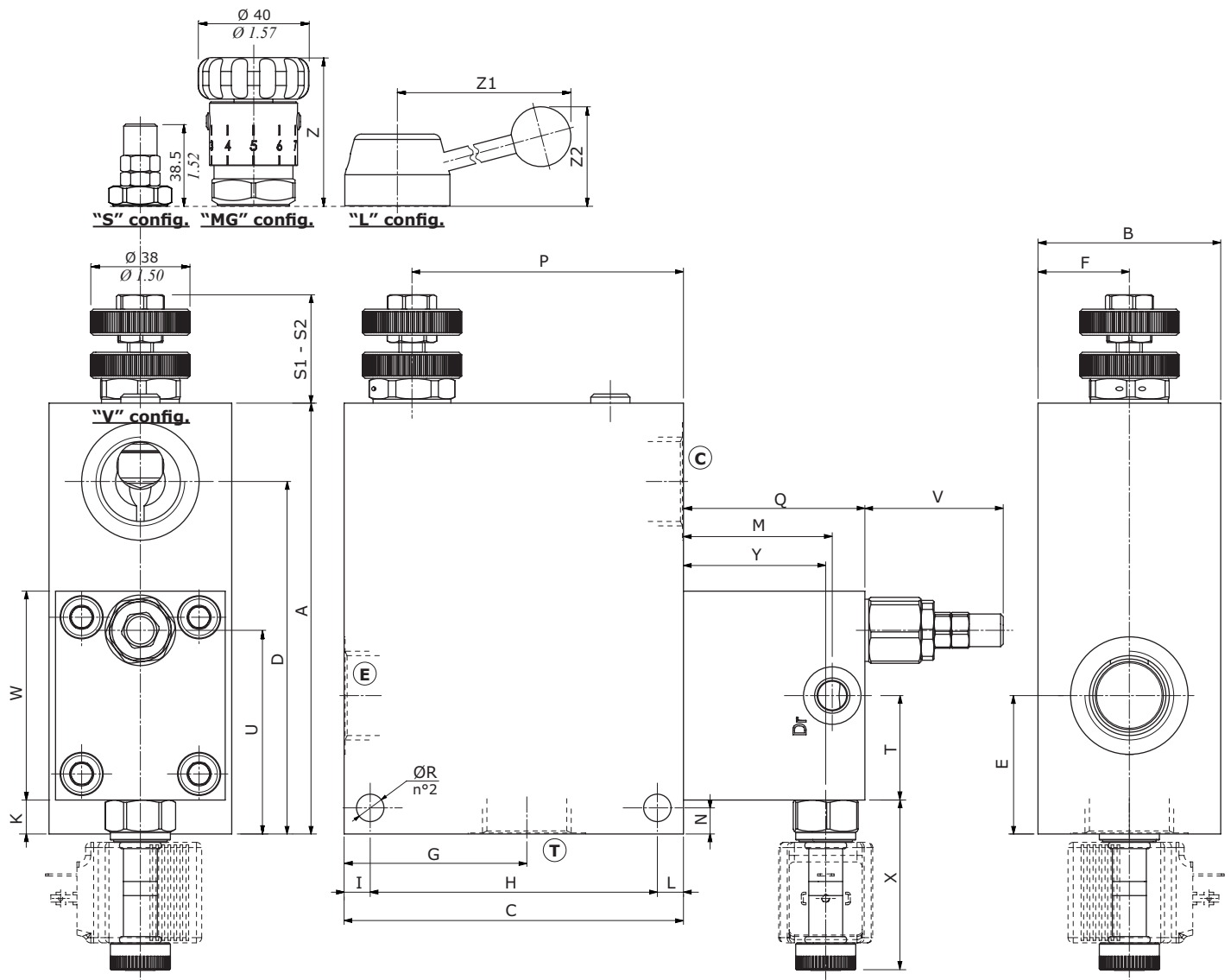

Ordering codes and description composition

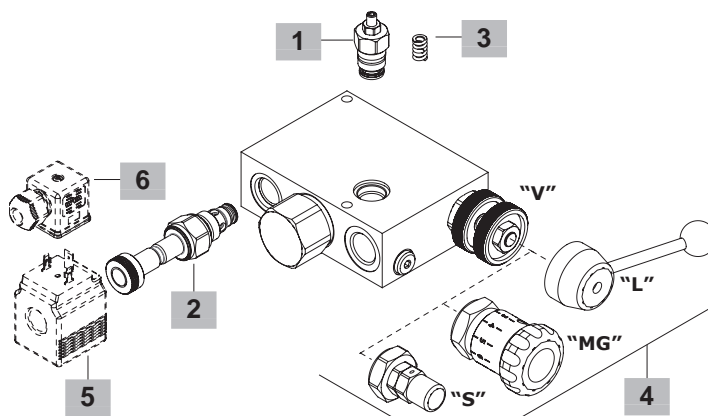

VPR/3/ET/VMP+VE complete valves

Adjustment kit type "V" (handwheel)

Configuration with normally open (NA) solenoid valve

TYPE: **VPR/3/ET 38+VMP+VE(EC08M).NA/V/02.TS** CODE: 1624021100

DESCRIPTION: alum. body, 3/8 ports, setting range 50-220 bar (725-3200 psi)

TYPE: **VPR/3/ET 12+VMP+VE(EC08M).NA/V/02.TS** CODE: 1624031100

DESCRIPTION: alum. body, 1/2 ports, setting range 50-220 bar (725-3200 psi)

TYPE: **VPR/3/ET 34+VMP+VE(EC08M).NA/V/02.TS** CODE: 1624041100

DESCRIPTION: alum. body, 3/4 ports, setting range 50-220 bar (725-3200 psi)

TYPE: **VPR/3/ET 100+VMP+VE(EC08M).NA/V/03.TS** CODE: 1624051100

DESCRIPTION: alum. body, 1" ports, setting range 50-200 bar (725-2900 psi)

TYPE: **VPR/3/ET 38+VMP+VE(EC08M).NA/V/02.TS/ac** CODE: 1624022101

DESCRIPTION: steel body, 3/8 ports, setting range 50-220 bar (725-3200 psi)

TYPE: **VPR/3/ET 12+VMP+VE(EC08M).NA/V/02.TS/ac** CODE: 1624032102

DESCRIPTION: steel body, 1/2 ports, setting range 50-220 bar (725-3200 psi)

TYPE: **VPR/3/ET 34+VMP+VE(EC08M).NA/V/02.TS/ac** CODE: 1624042100

DESCRIPTION: steel body, 3/4 ports, setting range 50-220 bar (725-3200 psi)

TYPE: **VPR/3/ET 100+VMP+VE(EC08M).NA/V/03.TS/ac** CODE: 1624052101

DESCRIPTION: steel body, 1" ports, setting range 50-200 bar (725-2900 psi)

Configuration with normally closed (NC) solenoid valve

TYPE: **VPR/3/ET 38+VMP+VE(EC08M).NC/V/02.TS** CODE: 1624021103

DESCRIPTION: alum. body, 3/8 ports, setting range 50-220 bar (725-3200 psi)

TYPE: **VPR/3/ET 12+VMP+VE(EC08M).NC/V/02.TS** CODE: 1624031103

DESCRIPTION: alum. body, 1/2 ports, setting range 50-220 bar (725-3200 psi)

TYPE: **VPR/3/ET 34+VMP+VE(EC08M).NC/V/02.TS** CODE: 1624041103

DESCRIPTION: alum. body, 3/4 ports, setting range 50-220 bar (725-3200 psi)

TYPE: **VPR/3/ET 100+VMP+VE(EC08M).NC/V/03.TS** CODE: 1624051103

DESCRIPTION: alum. body, 1" ports, setting range 50-200 bar (725-2900 psi)

Adjustment kit type "MG" (handknob)

Configuration with normally open (NA) solenoid valve

TYPE: **VPR/3/ET 38+VMP+VE(EC08M).NA/MG/02.TS** CODE: 1624021101

DESCRIPTION: alum. body, 3/8 ports, setting range 50-220 bar (725-3200 psi)

TYPE: **VPR/3/ET 12+VMP+VE(EC08M).NA/MG/02.TS** CODE: 1624031101

DESCRIPTION: alum. body, 1/2 ports, setting range 50-220 bar (725-3200 psi)

TYPE: **VPR/3/ET 34+VMP+VE(EC08M).NA/MG/02.TS** CODE: 1624041101

DESCRIPTION: alum. body, 3/4 ports, setting range 50-220 bar (725-3200 psi)

TYPE: **VPR/3/ET 100+VMP+VE(EC08M).NA/MG/03.TS** CODE: 1624051101

DESCRIPTION: alum. body, 1" ports, setting range 50-200 bar (725-2900 psi)

Configuration with normally closed (NC) solenoid valve

TYPE: **VPR/3/ET 38+VMP+VE(EC08M).NC/MG/02.TS** CODE: 1624021104

DESCRIPTION: alum. body, 3/8 ports, setting range 50-220 bar (725-3200 psi)

TYPE: **VPR/3/ET 12+VMP+VE(EC08M).NC/MG/02.TS** CODE: 1624031104

DESCRIPTION: alum. body, 1/2 ports, setting range 50-220 bar (725-3200 psi)

TYPE: **VPR/3/ET 34+VMP+VE(EC08M).NC/MG/02.TS** CODE: 1624041104

DESCRIPTION: alum. body, 3/4 ports, setting range 50-220 bar (725-3200 psi)

TYPE: **VPR/3/ET 100+VMP+VE(EC08M).NC/MG/03.TS** CODE: 1624051104

DESCRIPTION: alum. body, 1" ports, setting range 50-200 bar (725-2900 psi)

VPR/3/ET/VMP+VE complete valves

Adjustment kit type "L" (lever)

Configuration with electric valve normally open (NA)

TYPE: **VPR/3/ET 38+VMP+VE(EC08M).NA/L/02.TS** CODE: 1624021102

DESCRIPTION: alum. body, 3/8 ports, setting range 50-220 bar (725-3200 psi)

TYPE: **VPR/3/ET 12+VMP+VE(EC08M).NA/L/02.TS** CODE: 1624031102

DESCRIPTION: alum. body, 1/2 ports, setting range 50-220 bar (725-3200 psi)

TYPE: **VPR/3/ET 34+VMP+VE(EC08M).NA/L/02.TS** CODE: 1624041102

DESCRIPTION: alum. body, 3/4 ports, setting range 50-220 bar (725-3200 psi)

TYPE: **VPR/3/ET 100+VMP+VE(EC08M).NA/L/03.TS** CODE: 1624051102

DESCRIPTION: alum. body, 1" ports, setting range 50-200 bar (725-2900 psi)

Configuration with electric valve normally closed (NC)

TYPE: **VPR/3/ET 38+VMP+VE(EC08M).NC/L/02.TS** CODE: 1624021105

DESCRIPTION: alum. body, 3/8 ports, setting range 50-220 bar (725-3200 psi)

TYPE: **VPR/3/ET 12+VMP+VE(EC08M).NC/L/02.TS** CODE: 1624031105

DESCRIPTION: alum. body, 1/2 ports, setting range 50-220 bar (725-3200 psi)

TYPE: **VPR/3/ET 34+VMP+VE(EC08M).NC/L/02.TS** CODE: 1624041105

DESCRIPTION: alum. body, 3/4 ports, setting range 50-220 bar (725-3200 psi)

TYPE: **VPR/3/ET 100+VMP+VE(EC08M).NC/L/03.TS** CODE: 1624051105

DESCRIPTION: alum. body, 1" ports, setting range 50-200 bar (725-2900 psi)

For other steel body configurations, SAE thread and configurations with FPM (Viton) seals, please contact our Sales Dpt.

1 Pressure relief valve

TYPE	CODE	DESCRIPTION
------	------	-------------

For VPR/3/ET 38-12-34+VMP+VE valves

VMP 02/TS.S	1100000101	Direct acting cartridge, setting range 50-220 bar (725-3200 psi)
--------------------	------------	--

For VPR/3/ET 100+VMP+VE valve

MC08A/0S2B	0MC08002000	Direct acting cartridge, setting range 50-200 bar (725-2900 psi)
-------------------	-------------	--

2 Solenoid valve

TYPE	CODE	DESCRIPTION
------	------	-------------

EC08M/10NB	0EC08002031	Normally open (NA) configuration
EC08M/20NB	0EC08002032	Normally closed (NC) configuration

3 Pressure setting springs

TYPE	CODE	DESCRIPTION
------	------	-------------

For VPR/3/ET 38-12-34+VMP+VE valves

TV	3ML1081400	Setting range 5-80 bar (72.5-1150 psi)
TS	3ML1081401	Setting range 50-220 bar (725-3200 psi)
TR	3ML1081402	Setting range 180-350 bar (2600-5100 psi)

For VPR/3/ET 100+VMP+VE valve

TV	3ML1092500	Setting range 5-50 bar (72.5-725 psi)
TS	3ML1092501	Setting range 50-200 bar (725-2900 psi)
TR	3ML1092502	Setting range 150-350 bar (2200-5100 psi)

Flow control valves

Flow control pressure compensated valves

VPR/3/ET/VMP+VE

Ordering codes and description composition

4 Adjustment kit

TYPE	CODE	DESCRIPTION
For VPR/3/ET 38+VMP+VE valve		
V.SB	5KT6200200	"V" handwheel type in "SB" configuration (sensibilized adjustment)
V	5KT6130200	"V" handwheel type
MG	5KT6200202	"MG" handknob type
S	5KT6200211	"S" screw type
For VPR/3/ET 12+VMP+VE valves		
V.SB	5KT6130301	"V" handwheel type in "SB" configuration (sensibilized adjustment)
V	5KT6130200	"V" handwheel type
MG	5KT6200202	"MG" handknob type
S	5KT6200211	"S" screw type
For VPR/3/ET 34-100+VMP+VE valve		
V	5KT6130401	"V" handwheel type
MG	5KT6200400	"MG" handknob type
S	5KT6130404	"S" screw type
V.SB	5KT6130402	"V" handwheel type in "SB" configuration (sensibilized adjustment)

5 Coils

TYPE	CODE	DESCRIPTION
BER 12VDC	4SLE001200A	12VDC-ISO4400 coil for EC08M

For complete coils list see from page 433

6 Connector

TYPE	CODE	DESCRIPTION
ISO4400	4CN1009995	Connector

For complete connectors list see from page 433

Rating diagrams

VPR/3/ET 38+VMP+VE pressure compensation diagram (E→C)

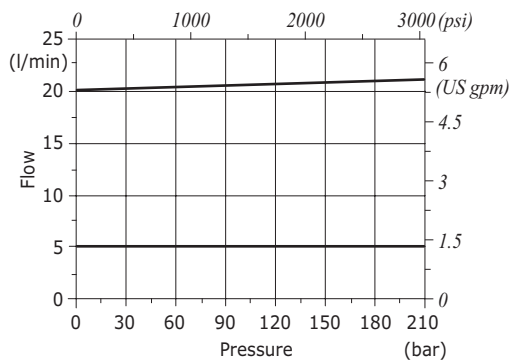

VPR/3/ET 12+VMP+VE pressure compensation diagram (E→C)

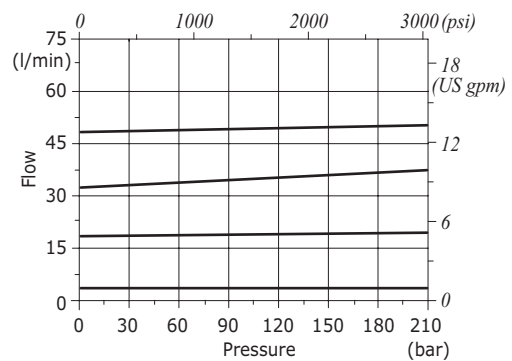

VPR/3/ET 34+VMP+VE pressure compensation diagram (E→C)

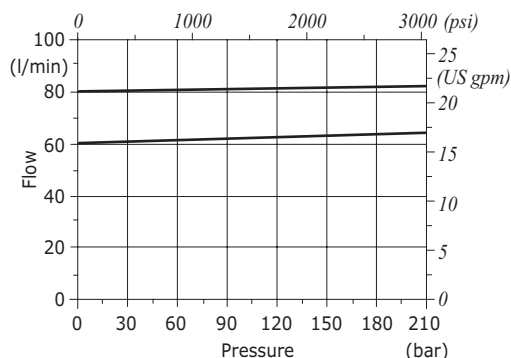

VPR/3/ET 100+VMP+VE pressure compensation diagram (E→C)

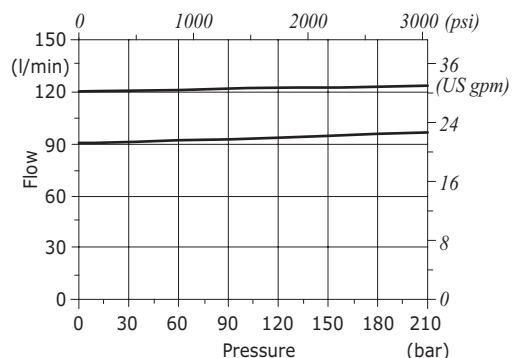



Type VPR/3/EP flow control pressure compensated valves

- 3 ways
- Exceeding flow to pressure

Technical specifications and diagrams are measured with mineral oil of 46 cSt viscosity at 40°C (104°F) temperature.

		VPR/3/EP 38	VPR/3/EP 12	VPR/3/EP 34	VPR/3/EP 100	VPR/3/EP 114
Max. inlet flow	Line E	50 l/min (13.2 US gpm)	90 l/min (23.8 US gpm)	150 l/min (39.6 US gpm)	240 l/min (63.4 US gpm)	450 l/min (119 US gpm)
Max. regulated flow	Line C	30 l/min (7.9 US gpm)	50 l/min (13.2 US gpm)	90 l/min (23.8 US gpm)	150 l/min (39.6 US gpm)	250 l/min (66.0 US gpm)
Max. regulated flow	"SB"	15 l/min (4.0 US gpm)	25 l/min (6.6 US gpm)	45 l/min (11.9 US gpm)	75 l/min (19.8 US gpm)	125 l/min (33.0 US gpm)
Max. pressure	Aluminium body = 210 bar (3050 psi) Steel body = 350 bar (5100 psi)					
Fluid	mineral based oil					
Viscosity	from 10 to 200 cSt					
Max. level of contamination	18/16/13 ISO4406					
Fluid temperature	with NBR seals from -20°C (-4°F) to 80°C (176°F)					
Environmental temp. for working conditions	from -40°C (-40°F) to 100°C (212°F)					
Weight	aluminium	1.26 kg (2.78 lb)	1.22 kg (2.69 lb)	2.49 kg (5.49 lb)	4.90 kg (10.80 lb)	5.19 kg (11.44 lb)
	steel	2.76 kg (6.08 lb)	2.79 kg (6.15 lb)	4.85 kg (10.69 lb)	9.73 kg (21.45 lb)	16.20 kg (35.71 lb)

NOTE - For different conditions, please contact Walvoil Sales Dpt.

*"SB" execution (sensibilized adjustment)

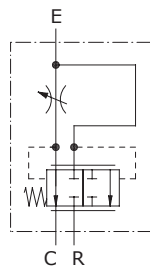

Dimensions

VPR/3/EP 38 - VPR/3/EP 12 - VPR/3/EP 34

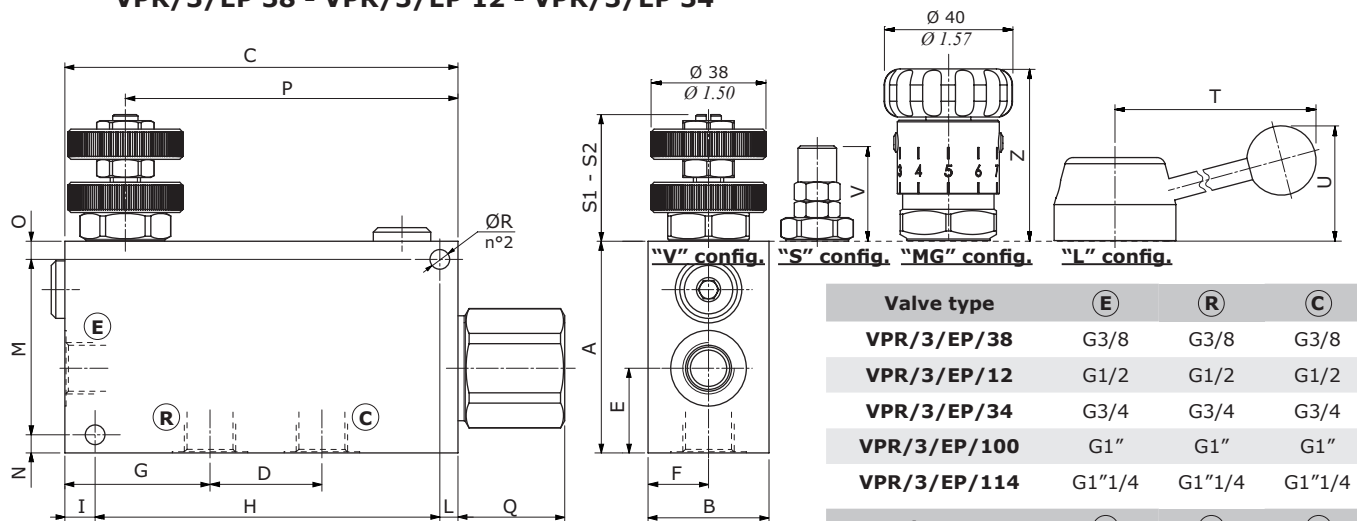

VPR/3/EP 100 - VPR/3/EP 114

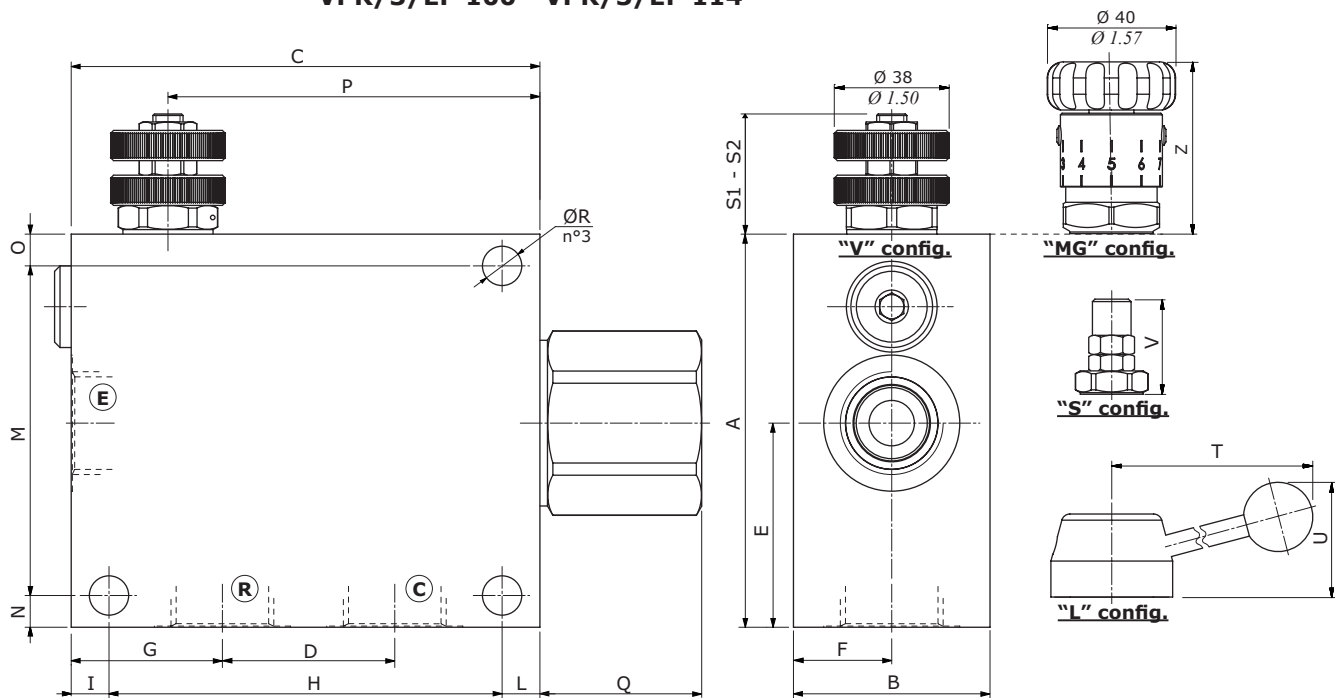

Valve type	A	B	C	D	E	F	G	H	I	L	M	N	O	P	Q	ØR	S1	S2	T	U	V	Z
VPR/3/EP/38	70	40	130	37	28	20	48	114	10	6	58	6	6	110	35	6.5	46.3	52.6	101.3	47.6	38.5	53.3
VPR/3/EP/38/SAE	2.76	1.57	5.12	1.46	1.10	0.79	1.89	4.49	0.394	0.236	2.28	0.236	0.236	4.33	1.38	0.256	1.82	2.07	3.99	1.87	1.52	2.10
VPR/3/EP/12	70	40	130	37	28	20	48	114	10	6	58	6	6	110	35	6.5	46.3	52.6	101.3	47.6	38.5	53.3
VPR/3/EP/12/SAE	2.76	1.57	5.12	1.46	1.10	0.79	1.89	4.49	0.394	0.236	2.28	0.236	0.236	4.33	1.38	0.256	1.82	2.07	3.99	1.87	1.52	2.10
VPR/3/EP/34	90	50	155	44	35	25	57	135	10	10	74	8	8	130	36.5	8.5	41.5	50.5	103.6	50.1	38.5	49.5
VPR/3/EP/34/SAE	3.54	1.97	6.10	1.73	1.38	0.98	2.24	5.31	0.394	0.394	2.91	0.315	0.315	5.12	1.44	0.335	1.63	1.99	4.08	1.97	1.52	1.95
VPR/3/EP/100	130	70	155	57	67.5	35	50	130	12.5	12.5	109	10.5	10.5	123	53.5	13	41.5	50.5	103.6	50.1	38.5	49.5
VPR/3/EP/100/SAE	5.12	2.76	6.10	2.24	2.66	1.38	1.97	5.12	0.49	0.49	4.29	0.413	0.413	4.84	2.11	0.51	1.63	1.99	4.08	1.97	1.52	1.95
VPR/3/EP/114	130	70	155	57	67.5	35	50	130	12.5	12.5	109	10.5	10.5	123	53.5	13	46.3	52.6	107.3	50.5	41.5	52.5
VPR/3/EP/114/SAE	5.12	2.76	6.10	2.24	2.66	1.38	1.97	5.12	0.49	0.49	4.29	0.413	0.413	4.84	2.11	0.51	1.82	2.07	4.22	1.99	1.63	2.07

Flow control valves

Flow control pressure compensated valves

VPR/3/EP

Ordering codes and description composition

Port size
VPR/3/EP 38/V
1

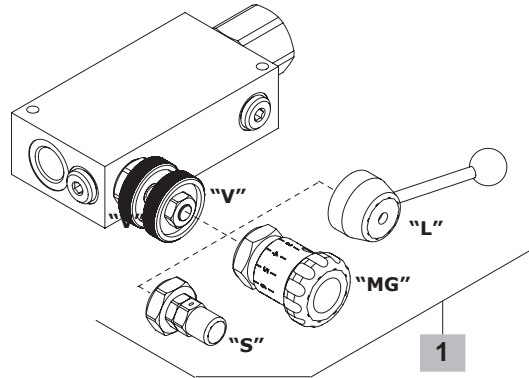

VPR/3/EP complete valves

TYPE	CODE	DESCRIPTION
Adjustment kit type "V" (handwheel)		
VPR/3/EP 38/V	1630021100	Aluminium body, 3/8 ports
VPR/3/EP 12/V	1630031100	Aluminium body, 1/2 ports
VPR/3/EP 34/V	1630041100	Aluminium body, 3/4 ports
VPR/3/EP 100/V	1630051100	Aluminium body, 1" ports
VPR/3/EP 114/V	1630061100	Aluminium body, 1 1/4 ports
VPR/3/EP 38/V/ac	1630022100	Steel body, 3/8 ports
VPR/3/EP 12/V/ac	1630032100	Steel body, 1/2 ports
VPR/3/EP 34/V/ac	1630042100	Steel body, 3/4 ports
VPR/3/EP 100/V/ac	1630052101	Steel body, 1" ports
VPR/3/EP 114/V/ac	1630062101	Steel body, 1 1/4 ports
VPR/3/EP 38/V/SAE	1630021200	Aluminium body, SAE8 ports
VPR/3/EP 12/V/SAE	1630031200	Aluminium body, SAE10 ports
VPR/3/EP 34/V/SAE	1630041200	Aluminium body, SAE12 ports
VPR/3/EP 100/V/SAE	1630051200	Aluminium body, SAE16 ports
VPR/3/EP 114/V/SAE	1630061200	Aluminium body, SAE20 ports
VPR/3/EP 34/V/SAE/ac	1630042200	Steel body, SAE12 ports
VPR/3/EP 100/V/SAE/ac	1630052200	Steel body, SAE16 ports
Adjustment kit type "MG" (handknob)		
VPR/3/EP 38/MG	1630021101	Aluminium body, 3/8 ports
VPR/3/EP 12/MG	1630031101	Aluminium body, 1/2 ports
VPR/3/EP 34/MG	1630041101	Aluminium body, 3/4 ports
VPR/3/EP 100/MG	1630051101	Aluminium body, 1" ports
VPR/3/EP 114/MG	1630061101	Aluminium body, 1 1/4 ports
Adjustment kit type "L" (lever)		
VPR/3/EP 38/L	1630021102	Aluminium body, 3/8 ports
VPR/3/EP 12/L	1630031102	Aluminium body, 1/2 ports
VPR/3/EP 34/L	1630041102	Aluminium body, 3/4 ports
VPR/3/EP 100/L	1630051102	Aluminium body, 1" ports
VPR/3/EP 114/L	1630061102	Aluminium body, 1 1/4 ports

For other steel body configurations, SAE thread and configurations with FPM (Viton) seals, please contact our Sales Dpt.

1 Adjustment kit

TYPE	CODE	DESCRIPTION
For VPR/3/EP 38 valve		
V.SB	5KT6200200	"V" handwheel type in "SB" configuration (sensibilized adjustment)
V	5KT6130200	"V" handwheel type
MG	5KT6200202	"MG" handknob type
S	5KT6200211	"S" screw type
For VPR/3/EP 12 valve		
V.SB	5KT6130301	"V" handwheel type in "SB" configuration (sensibilized adjustment)
V	5KT6130200	"V" handwheel type
MG	5KT6200202	"MG" handknob type
S	5KT6200211	"S" screw type
For VPR/3/EP 34-100 valves		
V	5KT6130401	"V" handwheel type
MG	5KT6200400	"MG" handknob type
S	5KT6130404	"S" screw type
V.SB	5KT6130402	"V" handwheel type in "SB" configuration (sensibilized adjustment)
For VPR/3/EP 114 valves		
V	5KT6340603	"V" handwheel type
MG	5KT6200605	"MG" handknob type
S	5KT6200604	"S" screw type

Rating diagrams

VPR/3/EP 38 compensation diagram in C
changing the Δp between E and R

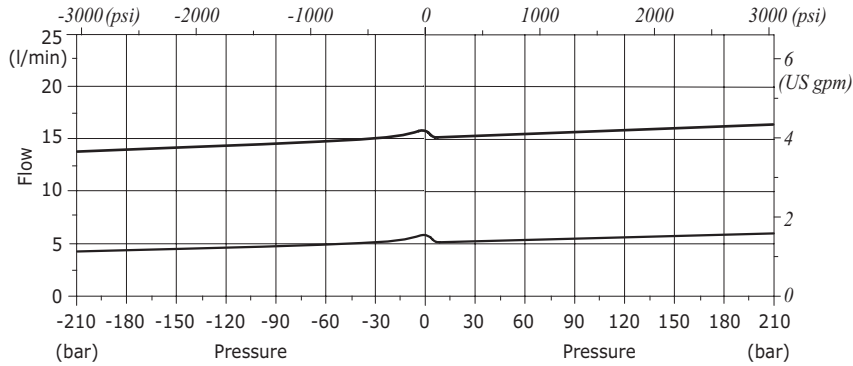

VPR/3/EP 12 compensation diagram in C
changing the Δp between E and R

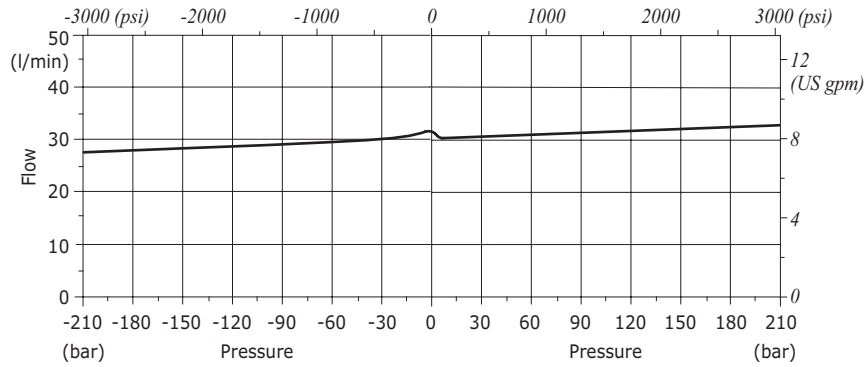

VPR/3/EP 34 compensation diagram in C
changing the Δp between E and R

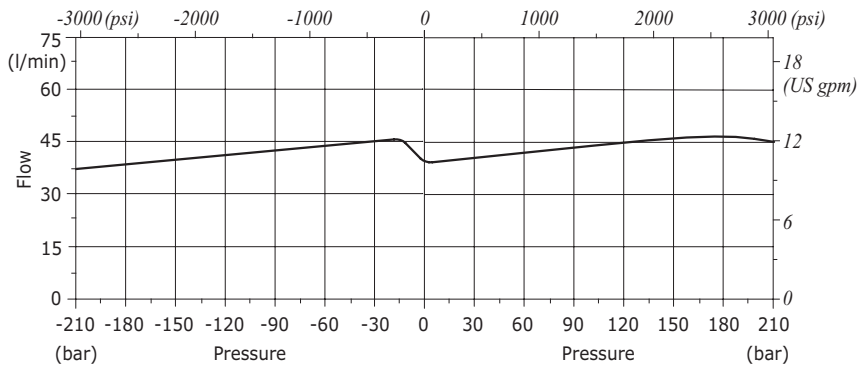

VPR/3/EP 100 compensation diagram in C changing the Δp between E and R

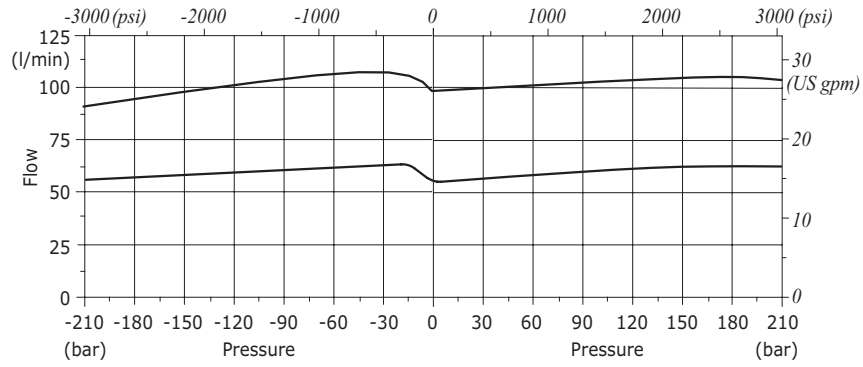

VPR/3/EP 114 compensation diagram in C changing the Δp between E and R

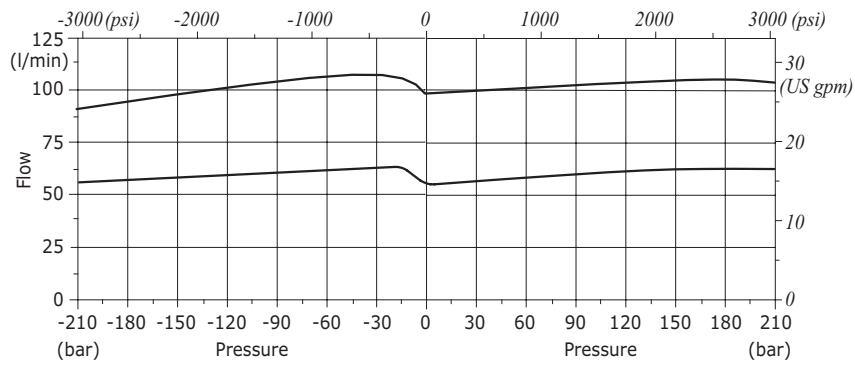

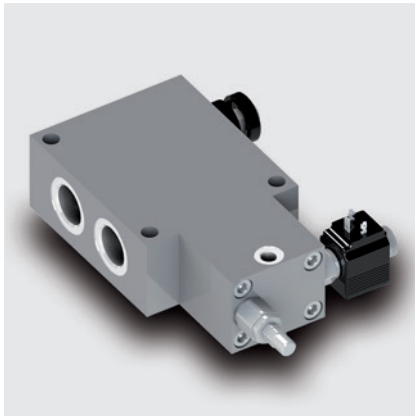

Type VPR/3/EP+VMP+VE flow control pressure compensated valves

- 3 ways
- Exceeding flow to pressure
- Electric venting
- With pressure relief valve

Technical specifications and diagrams are measured with mineral oil of 46 cSt viscosity at 40°C (104°F) temperature.

		VPR/3/EP 38	VPR/3/EP 12	VPR/3/EP 34	VPR/3/EP 100	VPR/3/EP 114
Max. inlet flow	Line E	50 l/min (13.2 US gpm)	90 l/min (23.8 US gpm)	150 l/min (39.6 US gpm)	240 l/min (63.4 US gpm)	450 l/min (119 US gpm)
Max. regulated flow	Line C	30 l/min (7.9 US gpm)	50 l/min (13.2 US gpm)	90 l/min (23.8 US gpm)	150 l/min (39.6 US gpm)	250 l/min (66 US gpm)
Max. regulated flow "SB"		15 l/min (4.0 US gpm)	25 l/min (6.6 US gpm)	45 l/min (11.9 US gpm)	75 l/min (18.1 US gpm)	125 l/min (33 US gpm)
Max. pressure		Aluminium body = 210 bar (3050 psi) Steel body = 350 bar (5100 psi)				
Fluid		mineral based oil				
Viscosity		from 10 to 200 cSt				
Max. level of contamination		18/16/13 ISO4406				
Fluid temperature		with NBR seals from -20°C (-4°F) to 80°C (176°F)				
Environmental temperature for working conditions		from -40°C (-40°F) to 100°C (212°F)				
Weight	aluminium	2.12 kg (4.67 lb)	2.10 kg (4.63 lb)	3.47 kg (7.65 lb)	5.49 kg (12.10 lb)	7.45 kg (16.42 lb)
	steel	4.19 kg (6.28 lb)	4.13 kg (6.17 lb)	7.03 kg (10.91 lb)	11.26 kg (24.83 lb)	18.20 kg (40.12 lb)

NOTE - For different conditions, please contact Walvoil Sales Dpt.

*"SB" execution (sensitized adjustment)

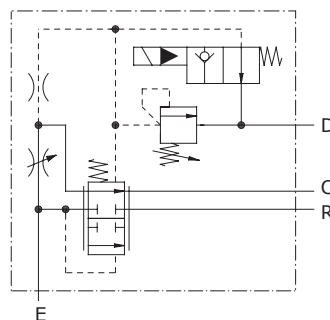

Dimensions

VPR/3/EP 38+VMP+VE - VPR/3/EP 12+VMP+VE - VPR/3/EP 34+VMP+VE

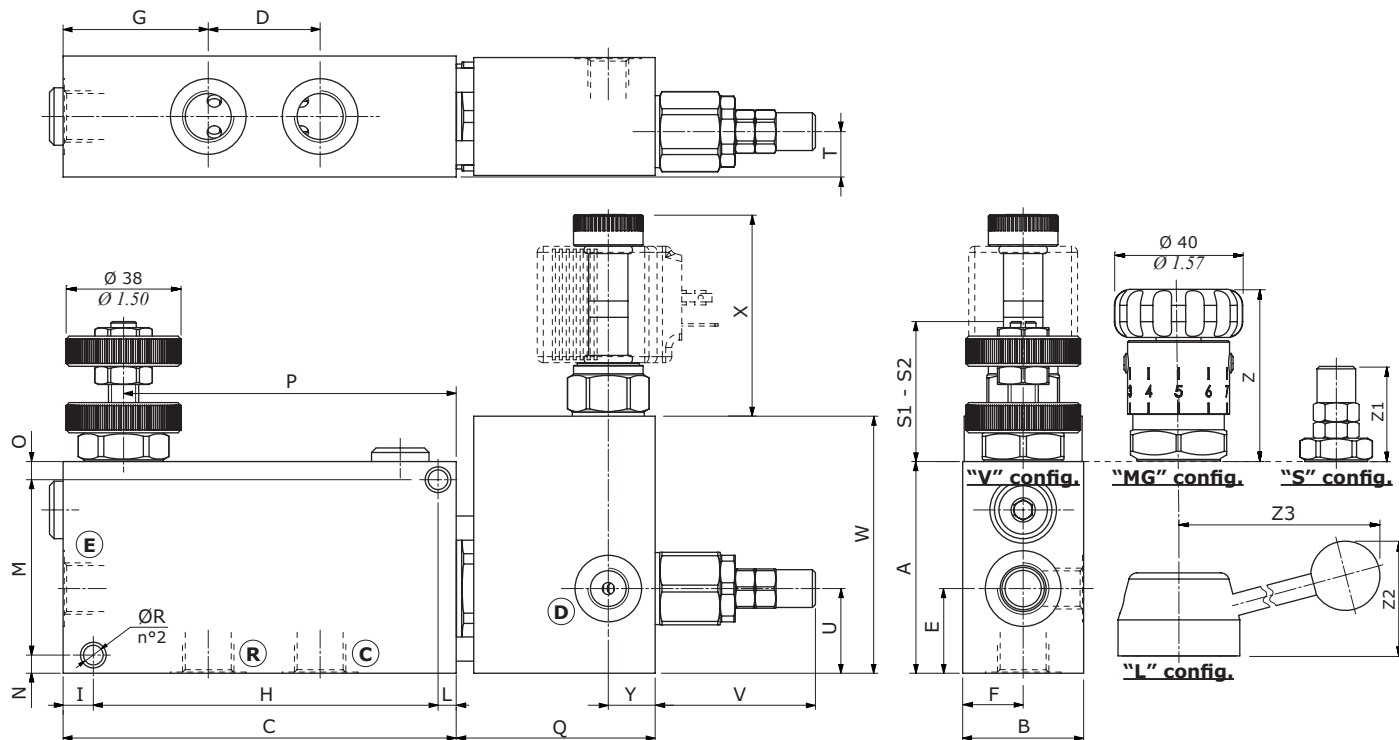

Valve type	Ⓔ	Ⓓ	Ⓒ	Ⓕ
VPR/3/EP 38+VMP+VE	G3/8	G3/8	G3/8	G1/4
VPR/3/EP 12+VMP+VE	G1/2	G1/2	G1/2	G1/4
VPR/3/EP 34+VMP+VE	G3/4	G3/4	G3/4	G1/4
VPR/3/EP 100+VMP+VE	G1"	G1"	G1"	G1/4
VPR/3/EP 114+VMP+VE	G1"1/4	G1"1/4	G1"1/4	G1/4

Dimensions are in mm-in

Valve type	A	B	C	D	E	F	G	H	I	L	K	J	M	N
VPR/3/EP 38+VMP+VE	70 2.76	40 1.57	130 5.12	37 1.46	28 1.10	20 0.79	48 1.89	114 4.49	10 0.394	6 0.236	-	-	58 2.28	6 0.236
VPR/3/EP 12+VMP+VE	70 2.76	40 1.57	130 5.12	37 1.46	28 1.10	20 0.79	48 1.89	114 4.49	10 0.394	6 0.236	-	-	58 2.28	6 0.236
VPR/3/EP 34+VMP+VE	90 3.54	50 1.97	155 6.10	44 1.73	35 1.38	25 0.98	57 2.24	135 5.31	10 0.394	10 0.394	15 0.59	35 1.38	74 2.91	8 0.315
VPR/3/EP 100+VMP+VE	130 5.12	Alum:70-2.76 Steel:65-2.56	155 6.10	57 2.24	67.5 2.66	Alum:35-1.38 Steel:32.5-1.28	50 1.97	130 5.12	12.5 0.49	12.5 0.49	12.5 0.49	67.5 2.66	109 4.29	10.5 0.413
VPR/3/EP 114+VMP+VE	160 6.30	75 2.95	184 7.24	70 2.76	83 3.27	37.5 1.48	60 2.36	159 6.26	12.5 0.49	12.5 0.49	15 0.59	83 3.27	135 5.31	12.5 0.49

Valve type	O	P	Q	ØR	S1	S2	T	U	V	W	X(NA)	Y	Z	Z1	Z2	Z3
VPR/3/EP 38+VMP+VE	6 0.236	110 4.33	65.8 2.59	6.5 0.256	46.3 1.82	52.6 2.07	15 0.59	28 1.10	53 2.09	85 3.35	66.7 2.63	15.5 0.61	53.3 2.10	38.5 1.52	47.5 1.87	101.3 3.99
VPR/3/EP 12+VMP+VE	6 0.236	110 4.33	65.8 2.59	6.5 0.256	46.3 1.82	53.1 2.09	14.5 0.59	28 1.10	53 2.09	85 3.35	66.7 2.63	15.5 0.61	53.3 2.10	38.5 1.52	47.5 1.87	101.3 3.99
VPR/3/EP 34+VMP+VE	8 0.315	130 5.12	76.8 3.02	8.5 0.335	41.5 1.63	50.5 1.99	-	35 1.38	53 2.09	90 3.54	66.7 2.63	16 0.63	49.5 1.95	38.5 1.52	50.1 1.97	103.6 4.08
VPR/3/EP 100+VMP+VE	10.5 0.413	123 4.84	69.5 2.74	13 0.51	41.5 1.63	50.5 1.99	-	42.5 1.67	53 2.09	107.5 4.23	62.5 2.46	15 0.59	49.5 1.95	38.5 1.52	50.1 1.97	103.6 4.08
VPR/3/EP 114+VMP+VE	12.5 0.49	151 5.94	80 3.15	12.5 0.49	52 2.05	xxx- xxx	-	58 2.28	53 2.09	123 4.84	66.7 2.63	15 0.59	52.5 2.06	41.5 1.63	50.5 1.99	107.3 4.22

VPR/3/EP 100+VMP+VE - VPR/3/EP 114+VMP+VE

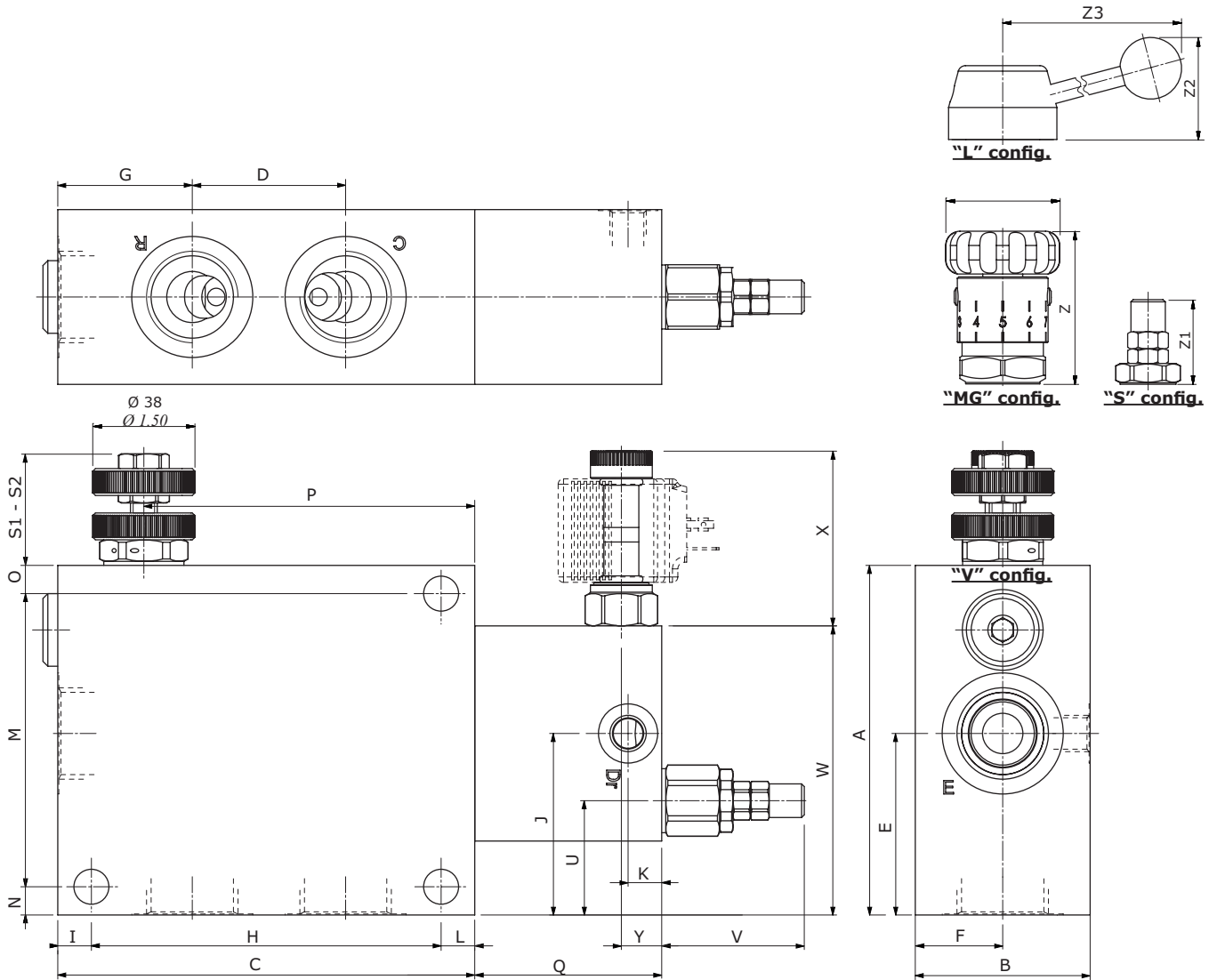

Ordering codes and description composition

VPR/3/EP 38+VMP+VE complete valves

Pressure relief valve setting range is 50-200 bar (725-2900 psi)

Adjustment kit type "V" (handwheel)

Configuration with normally open (NA) solenoid valve

TYPE: **VPR/3/EP 38+VMP+VE(EC08M).NA/V/03.TS** CODE: 1634021100

DESCRIPTION: aluminium body, 3/8 ports

TYPE: **VPR/3/EP 12+VMP+VE(EC08M).NA/V/03.TS** CODE: 1634031100

DESCRIPTION: aluminium body, 1/2 ports

TYPE: **VPR/3/EP 34+VMP+VE(EC08M).NA/V/03.TS** CODE: 1634041100

DESCRIPTION: aluminium body, 3/4 ports

TYPE: **VPR/3/EP 100+VMP+VE(EC08M).NA/V/03.TS** CODE: 1634051100

DESCRIPTION: aluminium body, 1" ports

TYPE: **VPR/3/EP 38+VMP+VE(EC08M).NA/V/03.TS/ac** CODE: 1634022100

DESCRIPTION: steel body, 3/8 ports

TYPE: **VPR/3/EP 12+VMP+VE(EC08M).NA/V/03.TS/ac** CODE: 1634032100

DESCRIPTION: steel body, 1/2 ports

TYPE: **VPR/3/EP 34+VMP+VE(EC08M).NA/V/03.TS/ac** CODE: 1634042100

DESCRIPTION: steel body, 3/4 ports

TYPE: **VPR/3/EP 100+VMP+VE(EC08M).NA/V/03.TS/ac** CODE: 1634052100

DESCRIPTION: steel body, 1" ports

TYPE: **VPR/3/EP 114+VMP+VE(EC08M).NA/V/03.TS/ac** CODE: 1634062100

DESCRIPTION: steel body, 1"1/4 ports

DESCRIPTION: steel body, 1"1/4 ports

DESCRIPTION: steel body, 1"1/4 ports

DESCRIPTION: steel body, 1"1/4 ports

DESCRIPTION: steel body, 1"1/4 ports

DESCRIPTION: steel body, 1"1/4 ports

DESCRIPTION: steel body, 1"1/4 ports

DESCRIPTION: steel body, 1"1/4 ports

DESCRIPTION: steel body, 1"1/4 ports

DESCRIPTION: steel body, 1"1/4 ports

DESCRIPTION: steel body, 1"1/4 ports

DESCRIPTION: steel body, 1"1/4 ports

DESCRIPTION: steel body, 1"1/4 ports

DESCRIPTION: steel body, 1"1/4 ports

DESCRIPTION: steel body, 1"1/4 ports

DESCRIPTION: steel body, 1"1/4 ports

DESCRIPTION: steel body, 1"1/4 ports

DESCRIPTION: steel body, 1"1/4 ports

DESCRIPTION: steel body, 1"1/4 ports

DESCRIPTION: steel body, 1"1/4 ports

DESCRIPTION: steel body, 1"1/4 ports

DESCRIPTION: steel body, 1"1/4 ports

DESCRIPTION: steel body, 1"1/4 ports

DESCRIPTION: steel body, 1"1/4 ports

DESCRIPTION: steel body, 1"1/4 ports

DESCRIPTION: steel body, 1"1/4 ports

DESCRIPTION: steel body, 1"1/4 ports

DESCRIPTION: steel body, 1"1/4 ports

DESCRIPTION: steel body, 1"1/4 ports

DESCRIPTION: steel body, 1"1/4 ports

DESCRIPTION: steel body, 1"1/4 ports

DESCRIPTION: steel body, 1"1/4 ports

DESCRIPTION: steel body, 1"1/4 ports

DESCRIPTION: steel body, 1"1/4 ports

DESCRIPTION: steel body, 1"1/4 ports

DESCRIPTION: steel body, 1"1/4 ports

DESCRIPTION: steel body, 1"1/4 ports

DESCRIPTION: steel body, 1"1/4 ports

DESCRIPTION: steel body, 1"1/4 ports

DESCRIPTION: steel body, 1"1/4 ports

DESCRIPTION: steel body, 1"1/4 ports

DESCRIPTION: steel body, 1"1/4 ports

DESCRIPTION: steel body, 1"1/4 ports

DESCRIPTION: steel body, 1"1/4 ports

DESCRIPTION: steel body, 1"1/4 ports

DESCRIPTION: steel body, 1"1/4 ports

DESCRIPTION: steel body, 1"1/4 ports

DESCRIPTION: steel body, 1"1/4 ports

DESCRIPTION: steel body, 1"1/4 ports

DESCRIPTION: steel body, 1"1/4 ports

DESCRIPTION: steel body, 1"1/4 ports

DESCRIPTION: steel body, 1"1/4 ports

DESCRIPTION: steel body, 1"1/4 ports

DESCRIPTION: steel body, 1"1/4 ports

DESCRIPTION: steel body, 1"1/4 ports

DESCRIPTION: steel body, 1"1/4 ports

DESCRIPTION: steel body, 1"1/4 ports

DESCRIPTION: steel body, 1"1/4 ports

DESCRIPTION: steel body, 1"1/4 ports

DESCRIPTION: steel body, 1"1/4 ports

DESCRIPTION: steel body, 1"1/4 ports

DESCRIPTION: steel body, 1"1/4 ports

DESCRIPTION: steel body, 1"1/4 ports

DESCRIPTION: steel body, 1"1/4 ports

DESCRIPTION: steel body, 1"1/4 ports

DESCRIPTION: steel body, 1"1/4 ports

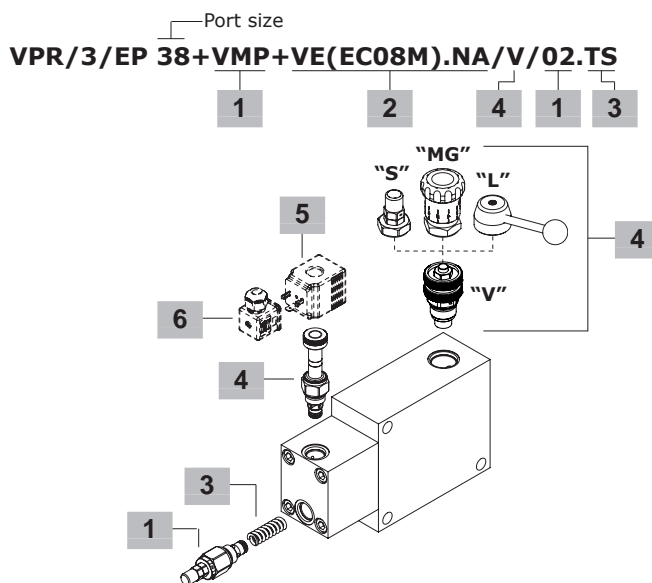

1 Pressure relief valve

TYPE	CODE	DESCRIPTION
MC08A/0S2B	0MC08002000	Direct acting cartridge, setting range 50-200 bar (725-2900 psi)

2 Solenoid valve

TYPE	CODE	DESCRIPTION
EC08M/10NB	0EC08002031	Normally open (NA) configuration
EC08M/20NB	0EC08002032	Normally closed (NC) configuration

3 Pressure setting springs

TYPE	CODE	DESCRIPTION
TV	3ML1092500	Setting range 5-50 bar (72.5-725 psi)
TS	3ML1092501	Setting range 50-200 bar (725-2900 psi)
TR	3ML1092502	Setting range 150-350 bar (2200-5100 psi)

4 Adjustment kit

TYPE	CODE	DESCRIPTION
For VPR/3/EP 38+VMP+VE valve		
V.SB	5KT6200200	"V" handwheel type in "SB" configuration (sensibilized adjustment)
V	5KT6130200	"V" handwheel type
MG	5KT6200202	"MG" handknob type
S	5KT6200211	"S" screw type
For VPR/3/EP 12+VMP+VE valve		
V.SB	5KT6130301	"V" handwheel type in "SB" configuration (sensibilized adjustment)
V	5KT6130200	"V" handwheel type
MG	5KT6200202	"MG" handknob type
S	5KT6200211	"S" screw type
For VPR/3/EP 34-100+VMP+VE valves		
V	5KT6130401	"V" handwheel type
MG	5KT6200400	"MG" handknob type
S	5KT6130404	"S" screw type
V.SB	5KT6130402	"V" handwheel type in "SB" configuration (sensibilized adjustment)
For VPR/3/EP 114+VMP+VE valve		
V	5KT6340603	"V" handwheel type
MG	5KT6200605	"MG" handknob type
S	5KT6200604	"S" screw type

5 Coils

TYPE	CODE	DESCRIPTION
BER 12VDC	4SLE001200A	12VDC-ISO4400 coil for EC08M

For complete coils list see from page 433

6 Connector

TYPE	CODE	DESCRIPTION
ISO4400	4CN1009995	Connector

For complete connectors list see from page 433

For other steel body configurations, SAE thread and configurations with FPM (Viton) seals, please contact our Sales Dpt.

**VPR/3/EP 38+VMP+VE compensation diagram in C
changing the Δp between E and R**

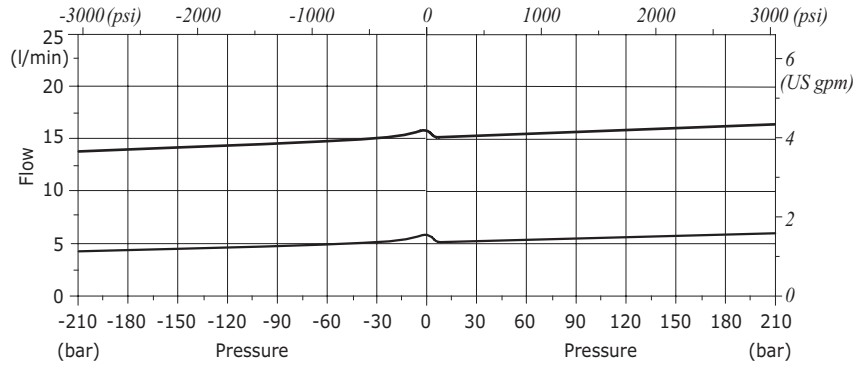

**VPR/3/EP 12+VMP+VE compensation diagram in C
changing the Δp between E and R**

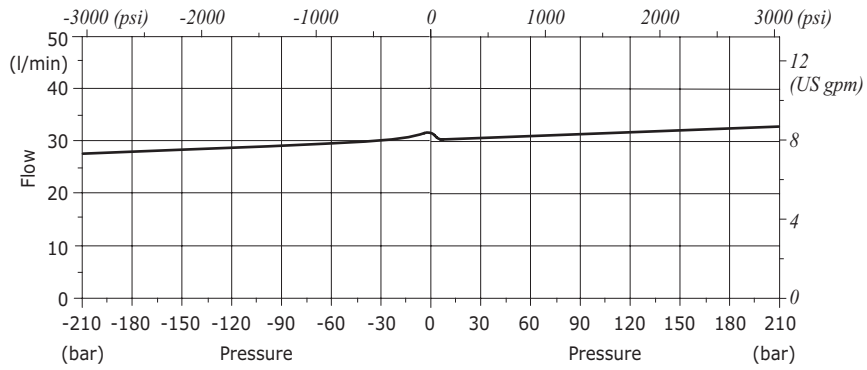

**VPR/3/EP 34+VMP+VE compensation diagram in C
changing the Δp between E and R**

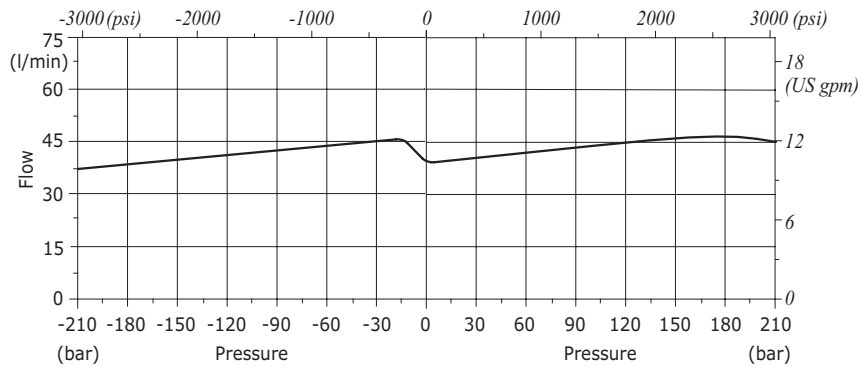

Rating diagrams

**VPR/3/EP 100/VMP+VE compensation diagram in C
changing the Δp between E and R**

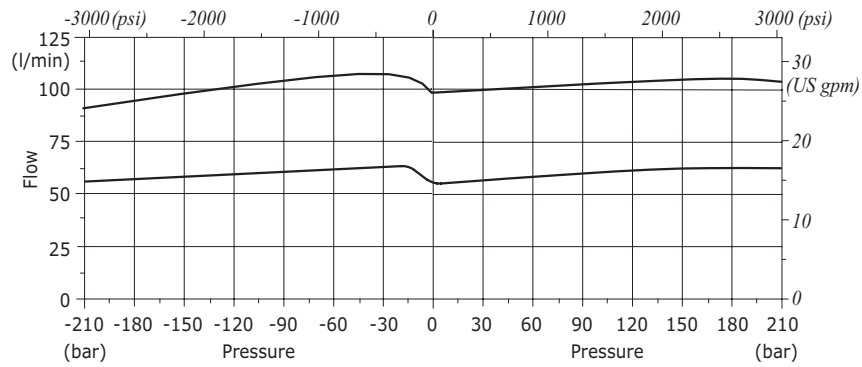

**VPR/3/EP 114/VMP+VE compensation diagram in C
changing the Δp between E and R**

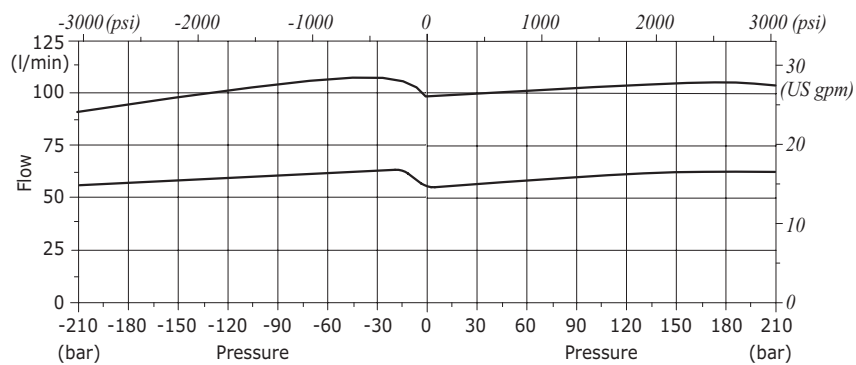

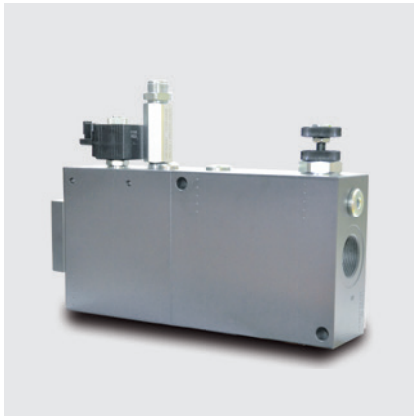

Type VPR/3/EP/VMP+VE/LPD flow control pressure compensated valves

- 3 ways
- Exceeding flow to pressure
- Electric venting
- With pressure relief valve
- Low pressure drop
- Steel body

Technical specifications and diagrams are measured with mineral oil of 46 cSt viscosity at 40°C (104°F) temperature.

		VPR/3/EP 34/VMP+VE/LPD	VPR/3/EP 100/VMP+VE/LPD	VPR/3/EP 114/VMP+VE/LPD
Max. inlet flow	Line E	150 l/min (39.6 US gpm)	240 l/min (63.4 US gpm)	450 l/min (119 US gpm)
Max. regulated flow	Line C	90 l/min (24 US gpm)	150 l/min (39.6 US gpm)	250 l/min (66 US gpm)
Max. pressure		350 bar (5100 psi)		
Fluid		mineral based oil		
Viscosity		from 10 to 200 cSt		
Max. level of contamination		18/16/13 ISO4406		
Fluid temperature		with NBR seals from -20°C (-4°F) to 80°C (176°F)		
Environmental temperature for working conditions		from -40°C (-40°F) to 100°C (212°F)		
Weight	steel	9.15 kg (20.17 lb)	19 kg (41.89 lb)	28 kg (61.73 lb)

NOTE - For different conditions, please contact Walvoil Sales Dpt.

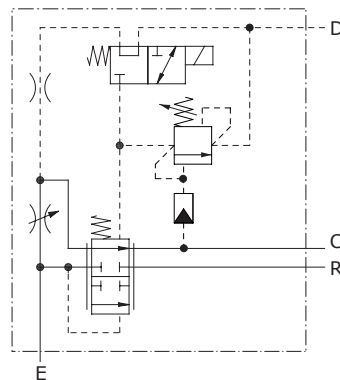

Dimensions

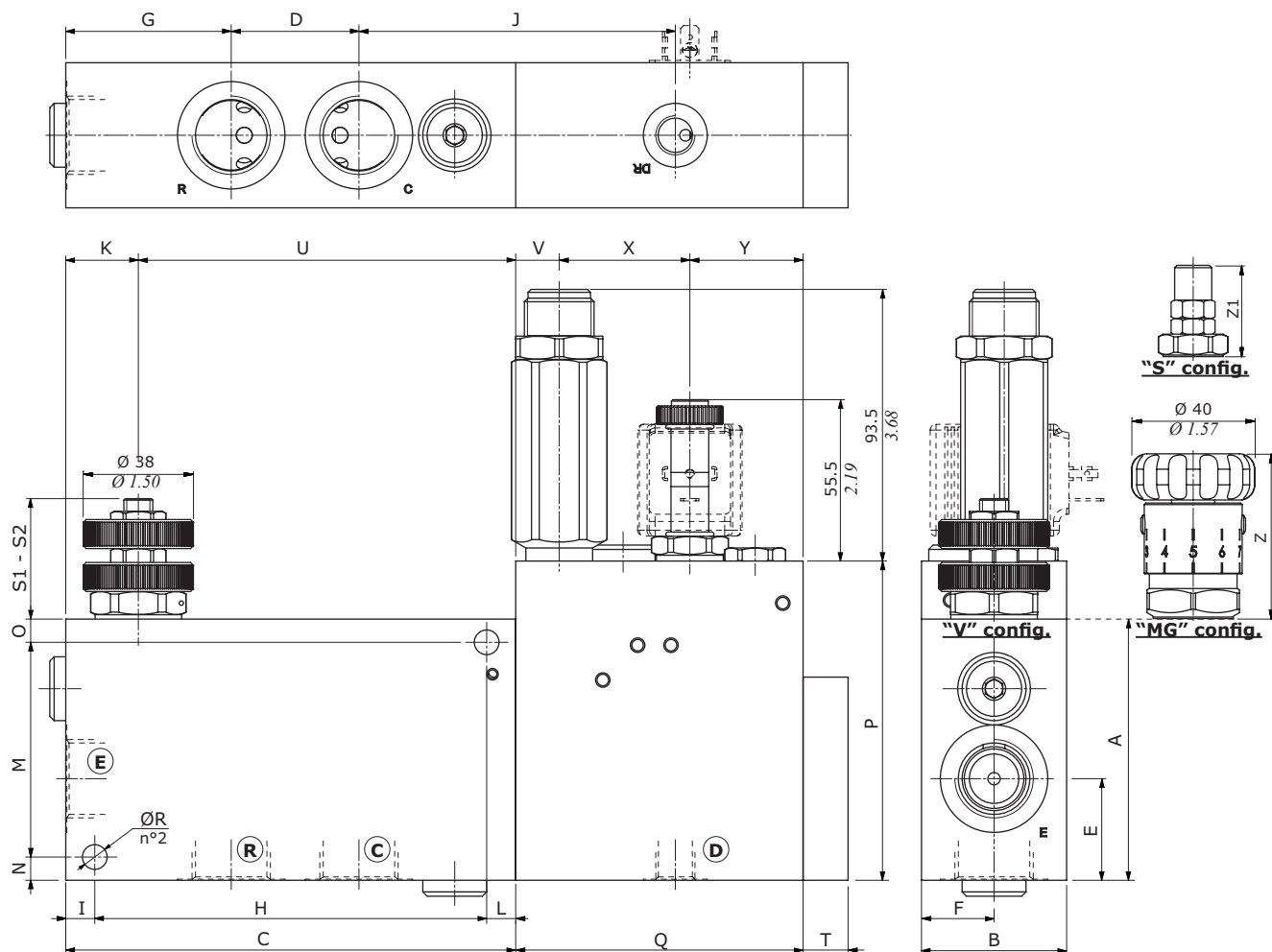

Valve type	(E)	(R)	(C)	(D)
VPR/3/EP 34/VMP+VE/LPD	G3/4	G3/4	G3/4	G1/4
VPR/3/EP 100/VMP+VE/LPD	G1"	G1"	G1"	G1/4
VPR/3/EP 114/VMP+VE/LPD	G1"1/4	G1"1/4	G1"1/4	G1/4

Dimensions are in mm-in

Valve type	A	B	C	D	E	F	G	H	I	L	K	J	M	N
VPR/3/EP 34/VMP+VE/LPD	90 3.54	50 1.97	155 6.10	44 1.73	35 1.38	25 0.98	57 2.24	135 5.31	10 0.394	10 0.394	25 0.98	109 4.29	74 2.91	8 0.315
VPR/3/EP 100/VMP+VE/LPD	130 5.12	65 2.56	155 6.10	57 2.24	67.5 2.66	32.5 1.28	50 1.97	130 5.12	12.5 0.49	12.5 0.49	32 1.26	121.5 4.78	109 4.29	10.5 0.413
VPR/3/EP 114/VMP+VE/LPD	160 6.30	75 2.95	184 7.24	70 2.76	83 3.27	37.5 1.48	60 2.36	159 6.26	12.5 0.49	12.5 0.49	35 1.38	147.5 5.81	135 5.31	12.5 0.49

Valve type	O	P	Q	ØR	S1	S2	T	U	V	X	Y	Z	Z1
VPR/3/EP 34/VMP+VE/LPD	8 0.315	110 4.33	99 3.90	8.5 0.335	-	-	15.5 0.61	130 5.12	15 0.59	54 2.13	39 1.54	56.5 2.22	38.5 1.52
VPR/3/EP 100/VMP+VE/LPD	10.5 0.413	147.5 5.81	113 4.45	12.5 0.49	-	-	17.5 0.69	123 4.84	38 1.50	35.5 1.40	39.5 1.56	56.5 2.22	38.5 1.52
VPR/3/EP 114/VMP+VE/LPD	12.5 0.49	160 6.30	144 5.67	12.5 0.49	-	-	17.5 0.69	149 5.87	49 1.93	41 1.61	54 2.13	56.5 2.22	41.5 1.63

Flow control valves

Flow control pressure compensated valves

VPR/3/EP/VMP+VE/LPD

Ordering codes and description composition

Port size
VPR/3/EP 34/VMP+VE.NA/LPD/V/VDS.TS/ac
 1 2 3 1 1

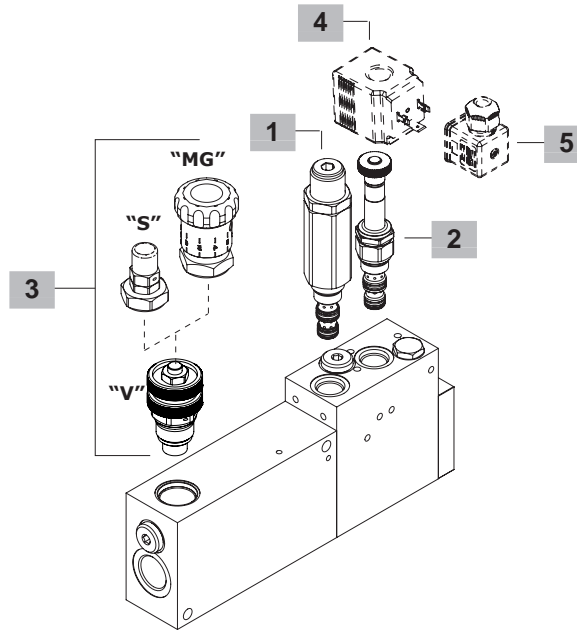

VPR/3/EP/VMP+VE/LPD complete valves

Standard setting 160 bar at 5 l/min (2320 psi at 1.32 US gpm)

Adjustment kit type "V" (handwheel)

TYPE: **VPR/3/EP 34/VMP+VE.NA/LPD/V/VDS.TS/ac**

CODE: 1635042103

DESCRIPTION: steel body, G3/4 ports, setting range 150-300 bar (2175-4350 psi)

TYPE: **VPR/3/EP 100/VMP+VE.NA/LPD/V/VDS.TS/ac**

CODE: 1635052103

DESCRIPTION: steel body, G1" ports, setting range 150-300 bar (2175-4350 psi)

TYPE: **VPR/3/EP 114/VMP+VE.NA/LPD/V/VDS.TS/ac**

CODE: 1635062102

DESCRIPTION: steel body, G1"1/4 ports, setting range 150-300 bar (2175-4350 psi)

For other steel body configurations, SAE thread and configurations with FPM (Viton) seals please contact our Sales Dpt.

1 Pressure relief valve

TYPE: **VDS/3/2 x VPR/3/EP....LPD/TS** CODE: 1208010400

DESCRIPTION: direct type valve, setting range 150-300 bar (2175-4350 psi), standard setting 160 bar at 5 l/min (2320 psi at 1.32 US gpm)

2 Solenoid valve

TYPE	CODE	DESCRIPTION
MC08A/0S2B	0EJ08002051	Normally open (NA) configuration

3 Adjustment kit

TYPE	CODE	DESCRIPTION
For VPR/3/EP 34-100+VMP+VE valves		
V	5KT6130401	"V" handwheel type
MG	5KT6200400	"MG" handknob type
S	5KT6130404	"S" screw type
For VPR/3/EP 114+VMP+VE valve		
V	5KT6340603	"V" handwheel type
MG	5KT6200605	"MG" handknob type
S	5KT6200604	"S" screw type

4 Coils

TYPE	CODE	DESCRIPTION
BER 12VDC	4SLE001200A	12VDC-ISO4400 coil

For complete coils list see from page 433

5 Connector

TYPE	CODE	DESCRIPTION
ISO4400	4CN1009995	Connector

For complete connectors list see from page 433

Rating diagrams

**VPR/3/EP 34/VMP+VE/LPD compensation diagram
in C changing the Δp between E and R**

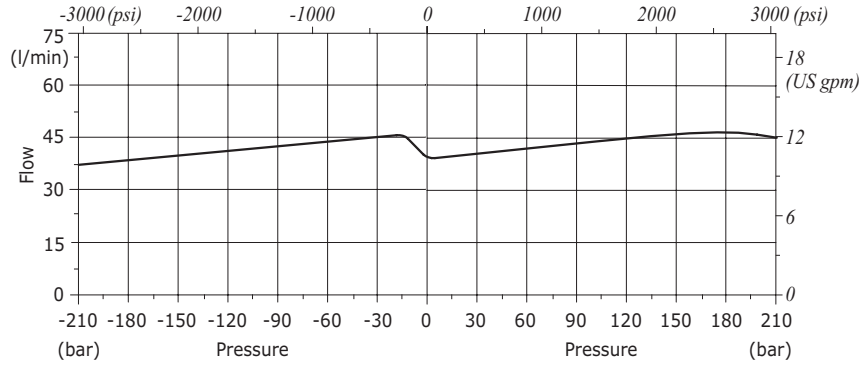

**VPR/3/EP 100/VMP+VE/LPD compensation diagram
in C changing the Δp between E and R**

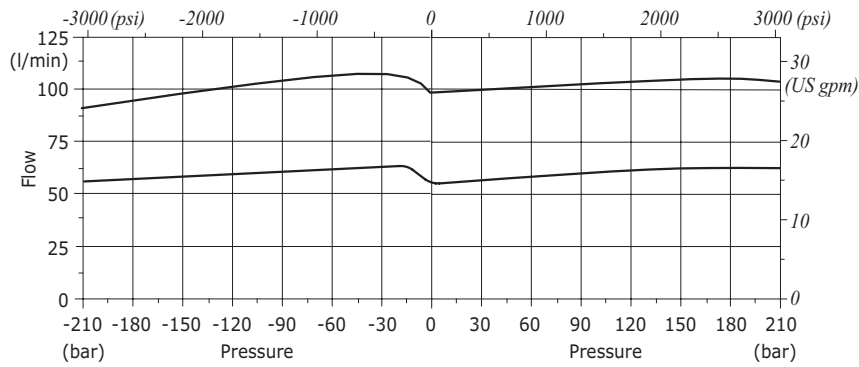

**VPR/3/EP 114/VMP+VE/LPD compensation diagram
in C changing the Δp between E and R**

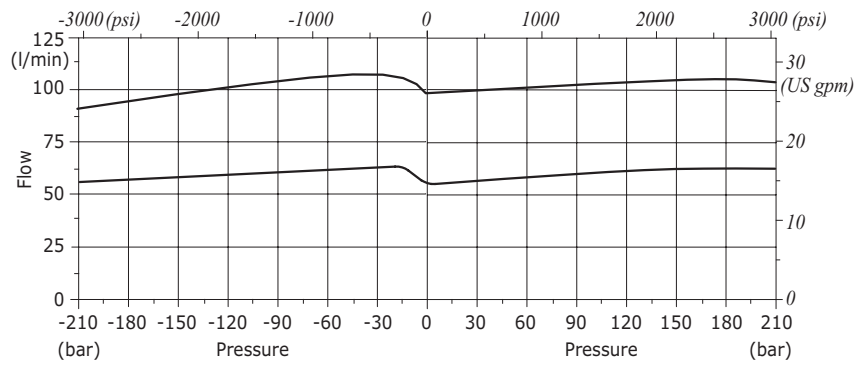



Type VDR flow control pressure compensated valves

- Cartridge compensated
- With steel housing M-F or F-F
- Flow regulator adjustable type

Technical specifications and diagrams are measured with mineral oil of 46 cSt viscosity at 40°C (104°F) temperature.

	VDR 14	VDR 38	VDR 12	VDR 34
Nominal flow from A to B	25 l/min (6.6 US gpm)	50 l/min (13.2 US gpm)	90 l/min (23.8 US gpm)	220 l/min (58.1 US gpm)
Nominal flow from B to A	10 l/min (2.6 US gpm)	25 l/min (6.6 US gpm)	67 l/min (17.7 US gpm)	150 l/min (39.6 US gpm)
Max. pressure	300 bar (4350 psi)			
Fluid	mineral based oil			
Viscosity	from 10 to 200 cSt			
Max. level of contamination	18/16/13 ISO4406			
Fluid temperature	with NBR seals from -20°C (-4°F) to 80°C (176°F)			
Environmental temp. for working conditions	from -40°C (-40°F) to 100°C (212°F)			
Weight	steel 0.012 kg (0.026 lb)	0.022 kg (0.048 lb)	0.036 kg (0.079 lb)	0.069 kg (0.152 lb)

NOTE - For different conditions, please contact Walvoil Sales Dpt.

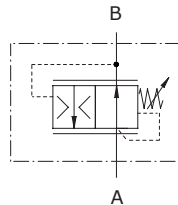

Dimension

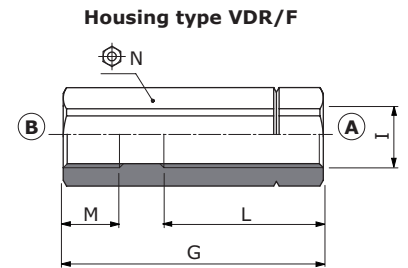
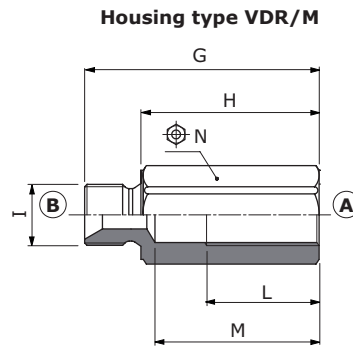
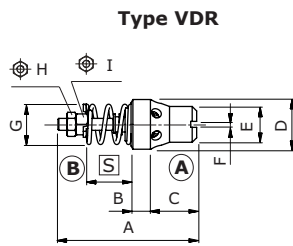

Dimensions are in mm-in

Valve type	A	B	C	D	E	F	G	⊕H	⊕I	S min-max
VDR 14	39 1.53	8 0.31	11.5 0.45	G 1/4	10 0.39	-	10 0.39	5.5	5.5	6-10.5 0.236-0.413
VDR 38	45 1.77	6 0.24	16 0.63	G 3/8	11.5 0.45	2 0.08	13.5 0.53	6	7	10.5-15.5 0.413-0.61
VDR 12	50 1.97	7 0.27	17 0.67	G 1/2	16 0.63	2 0.08	18 0.71	6	7	13-19 0.511-0.748
VDR 34	60 2.36	9.5 0.37	21.5 0.55	G 3/4	20 0.79	2 0.08	23 0.9	6	7	14-20.5 0.551-0.807

Dimensions are in mm-in

Housing type	G	H	I	L	M	⊕N	
M	14	76 2.99	66 2.6	G 1/4	41 1.61	19 0.75	19
	38	82 3.23	70 2.75	G 3/8	41 1.61	22 0.87	22
	12	100 3.94	86 3.38	G 1/2	45 1.77	27 1.06	27
	34	112 4.41	96 3.78	G 3/4	55 2.16	32 1.26	32
F	14	66 2.6	-	G 1/4	34 1.34	19 0.75	19
	38	70 2.75	-	G 3/8	37 1.45	22 0.87	22
	12	80 3.15	-	G 1/2	41 1.61	27 1.06	27
	34	100 3.94	-	G 3/4	54 2.12	32 1.26	32

Flow control valves

Flow control pressure compensated valves

Ordering codes and description composition

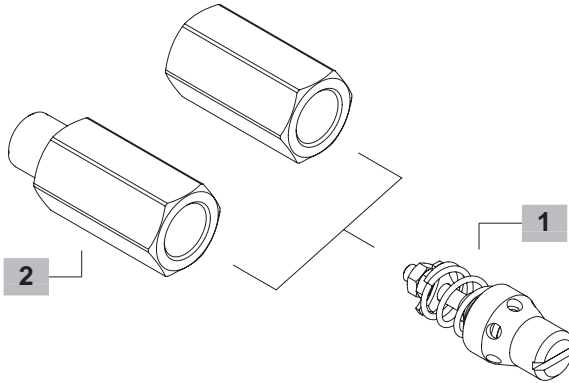
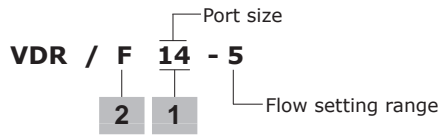

Type	Flow setting range			
	VDR 14	VDR 38	VDR 12	VDR 34
	l/min US gpm	l/min US gpm	l/min US gpm	l/min US gpm
1	1 - 1.6 0.26 - 0.42	2.5 - 4 0.66 - 1.06	16 - 21 4.2 - 5.6	37 - 50 9.8 - 13.2
2	1.6 - 2.5 0.42 - 0.66	4 - 6.3 1.06 - 1.66	21 - 28 5.5 - 7.4	50 - 67 13.2 - 17.7
3	2.5 - 4 0.66 - 1.06	6.3 - 10 1.66 - 2.64	28 - 37 7.4 - 9.8	67 - 90 17.7 - 23.8
4	4 - 6.3 1.06 - 1.66	10 - 16 2.64 - 4.2	37 - 50 9.8 - 13.2	90 - 120 23.8 - 31.7
5	6.3 - 10 1.66 - 2.64	16 - 25 4.2 - 6.6	50 - 67 13.2 - 17.7	120 - 150 31.7 - 39.6

NOTE - l/min @ 50 bar (720 psi)

VDR complete valves

Chartridge with steel housing

TYPE	CODE	DESCRIPTION
VDR/F 14-1	1661110100	Female-female G1/4 ports, range type 1
VDR/F 38-2	1661120100	Female-female G3/8 ports, range type 2
VDR/F 12-2	1661130100	Female-female G1/2 ports, range type 2
VDR/F 34-3	1661140100	Female-female G3/4 ports, range type 3
VDR/M 14-1	1661210100	Male-female G1/4 ports, range type 1
VDR/M 38-2	1661220100	Male-female G3/8 ports, range type 2
VDR/M 12-2	1661230100	Male-female G1/2 ports, range type 2
VDR/M 34-3	1661240100	Male-female G3/4 ports, range type 3

For different configurations or SAE thread please contact our Sales Dpt.

2 Housing

M-F (male-female) or F-F (female-female) steel housing

TYPE	CODE	DESCR.	TYPE	CODE	DESCR.
MF14	CMFVRD01	G1/4, M-F	MF03	CMFVRD03	G1/2, M-F
FF14	CFFVRD01	G1/4, F-F	FF03	CFFVRD03	G1/2, F-F
MF02	CMFVRD02	G3/8, M-F	MF04	CMFVRD04	G3/4, M-F
FF02	CFFVRD02	G3/8, F-F	FF04	CFFVRD04	G3/4, F-F

For different configurations or SAE thread please contact our Sales Dpt.

1 Valve

TYPE	CODE	DESCRIPTION
With G1/4 ports		
VDR 14-1	1661010100	Range type 1
VDR 14-2	1661010101	Range type 2
VDR 14-3	1661010102	Range type 3
VDR 14-4	1661010103	Range type 4
VDR 14-5	1661010104	Range type 5
With G3/8 ports		
VDR 38-1	1661020100	Range type 1
VDR 38-2	1661020101	Range type 2
VDR 38-3	1661020102	Range type 3
VDR 38-4	1661020103	Range type 4
VDR 38-5	1661020104	Range type 5
With G1/2 ports		
VDR 12-1	1661030100	Range type 1
VDR 12-2	1661030101	Range type 2
VDR 12-3	1661030102	Range type 3
VDR 12-4	1661030103	Range type 4
VDR 12-5	1661030104	Range type 5
With G3/4 ports		
VDR 34-1	1661040100	Range type 1
VDR 34-2	1661040101	Range type 2
VDR 34-3	1661040102	Range type 3
VDR 34-4	1661040103	Range type 4
VDR 34-5	1661040104	Range type 5

Rating diagrams

VDR 14 pressure flow setting range

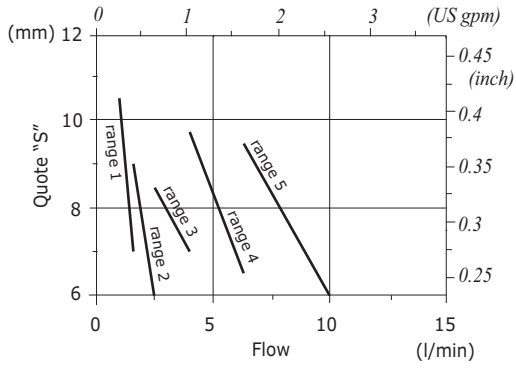

VDR 38 pressure flow setting range

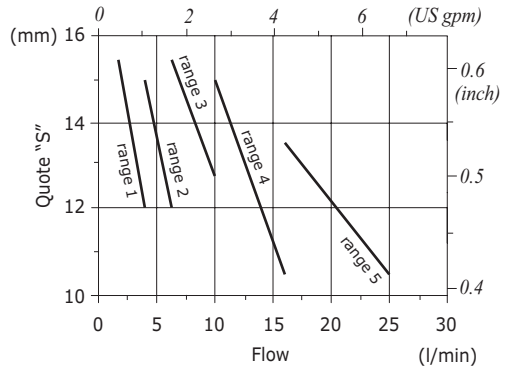

VDR 12 pressure flow setting range

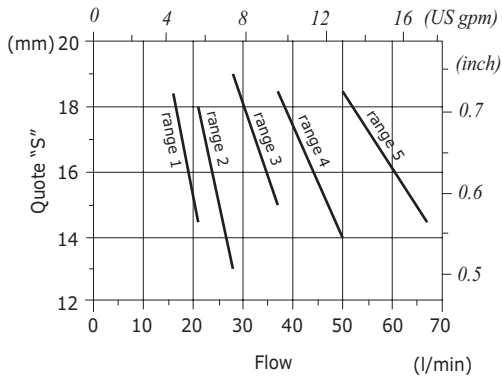

VDR 34 pressure flow setting range

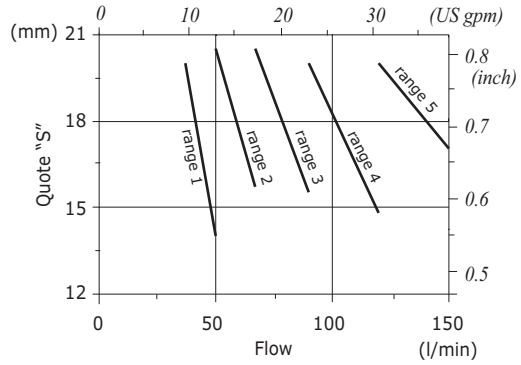



Type VDR/CO flow control pressure compensated valves

- Cartridge compensated
- With steel housing M-F or F-F
- Flow regulator fixed type

Technical specifications and diagrams are measured with mineral oil of 46 cSt viscosity at 40°C (104°F) temperature.

	VDR/CO 14	VDR/CO 38	VDR/CO 12
Nominal flow from A to B	15 l/min (3.96 US gpm)	25 l/min (6.6 US gpm)	60 l/min (15.9 US gpm)
Nominal flow from B to A	10 l/min (2.6 US gpm)	16 l/min (4.2 US gpm)	45 l/min (11.9 US gpm)
Max. pressure		350 bar (5100 psi)	
Fluid		mineral based oil	
Viscosity		from 10 to 200 cSt	
Max. level of contamination		18/16/13 ISO4406	
Fluid temperature		with NBR seals from -20°C (-4°F) to 80°C (176°F)	
Environmental temperature for working conditions		from -40°C (-40°F) to 100°C (212°F)	
Weight	steel 0.01 kg (0.022 lb)	0.026 kg (0.057 lb)	0.05 kg (0.11 lb)

NOTE - For different conditions, please contact Walvoil Sales Dpt.

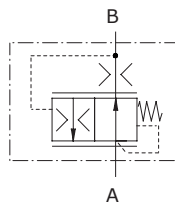

Dimension

Type VDR/CO

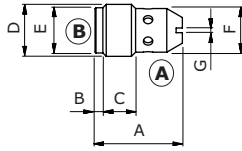

Housing type VDR/CO/M

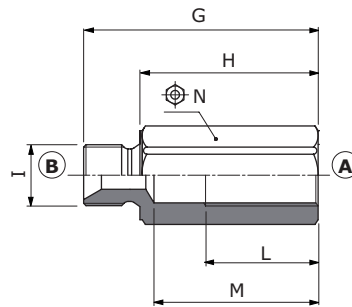

Housing type VDR/CO/F

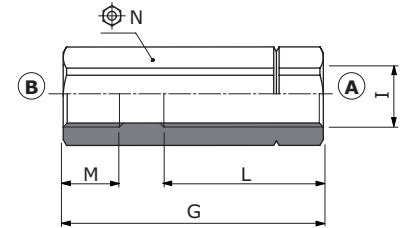

Dimensions are in mm-in

Valve type	A	B	C	D	E	F	G
VDR/CO 14	23 0.9	1.5 0.06	7 0.27	G 1/4	-	10.5 0.41	1.5 0.06
VDR/CO 38	28 1.1	2.5 0.1	10.5 0.41	G 3/8	14.5 0.57	14 0.55	1.5 0.06
VDR/CO 12	36 1.42	5 0.2	12 0.47	G 1/2	18 0.71	17 0.67	2 0.08

Dimensions are in mm-in

Housing type	G	H	I	L	M	N
14	62 2.44	50 1.97	G 1/4	42 1.65	45 1.77	19
MF 38	82 3.23	70 2.75	G 3/8	41 1.61	63 2.48	22
12	100 3.94	86 3.38	G 1/2	45 1.77	79 3.11	27
14*	50 1.97	-	G 1/4	-	-	19
FF 38	70 2.75	-	G 3/8	-	-	22
12	80 3.15	-	G 1/2	-	-	27

NOTE - (*) valve to be inserted in the reverse direction.

Flow control valves

Flow control pressure compensated valves

VDR/CO

Ordering codes and description composition

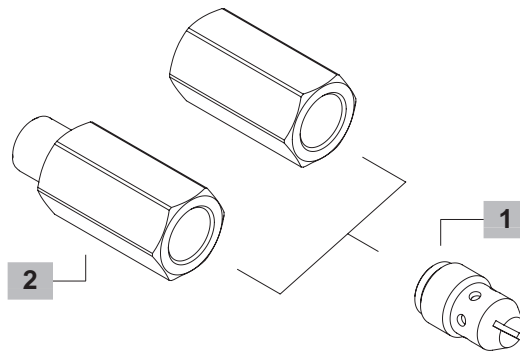
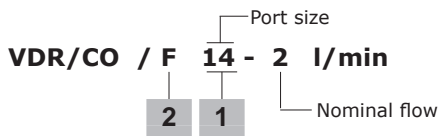

VDR/CO complete valves

Chartridge with steel housing

TYPE	CODE	DESCRIPTION
VDR/CO/F 14-2	1661610100	Female-female G1/4 ports, range 2 l/min - 0.53 US gpm
VDR/CO/F 38-2	1661620100	Female-female G3/8 ports, range 2 l/min - 0.53 US gpm
VDR/CO/F 12-12	1661630100	Female-female G1/2 ports, range 12 l/min - 3.2 US gpm
VDR/CO/M 14-2	1661710100	Male-female G1/4 ports, range 2 l/min - 0.53 US gpm
VDR/CO/M 38-2	1661720100	Male-female G3/8 ports, range 2 l/min - 0.53 US gpm
VDR/CO/M 12-12	1661730100	Male-female G1/2 ports, range 12 l/min - 3.2 US gpm

For different configurations or SAE thread please contact our Sales Dpt.

2 Housing

M-F (male-female) or F-F (female-female) steel housing

TYPE	CODE	DESCR.	TYPE	CODE	DESCR.
MF14	CMFVSC01	G1/4, M-F	MF03	CMFVSC03	G1/2, M-F
FF14	CFFVUBA-VSC01	G1/4, F-F	FF03	CFFVSC03	G1/2, F-F
MF02	CMFVSC02	G3/8, M-F	MF04	CMFVSC04	G3/4, M-F
FF02	CFFVSC02	G3/8, F-F	FF04	CFFVSC04	G3/4, F-F

For different configurations or SAE thread please contact our Sales Dpt.

1 Valve

TYPE	CODE	DESCRIPTION
With G1/4 ports		
VDR/CO 14-1	1661510100	Nominal flow 1 l/min - 0.26 US gpm
VDR/CO 14-2	1661510101	Nominal flow 2 l/min - 0.53 US gpm
VDR/CO 14-3	1661510102	Nominal flow 3 l/min - 0.79 US gpm
VDR/CO 14-4	1661510103	Nominal flow 4 l/min - 1.06 US gpm
VDR/CO 14-5	1661510104	Nominal flow 5 l/min - 1.32 US gpm
VDR/CO 14-6	1661510105	Nominal flow 6 l/min - 1.58 US gpm
VDR/CO 14-7	1661510106	Nominal flow 7 l/min - 1.85 US gpm
VDR/CO 14-8	1661510107	Nominal flow 8 l/min - 2.11 US gpm
VDR/CO 14-9	1661510108	Nominal flow 9 l/min - 2.38 US gpm
VDR/CO 14-10	1661510109	Nominal flow 10 l/min - 2.64 US gpm
With G3/8 ports		
VDR/CO 38-2	1661520100	Nominal flow 2 l/min - 0.53 US gpm
VDR/CO 38-4	1661520101	Nominal flow 4 l/min - 1.06 US gpm
VDR/CO 38-6	1661520102	Nominal flow 6 l/min - 1.58 US gpm
VDR/CO 38-8	1661520103	Nominal flow 8 l/min - 2.11 US gpm
VDR/CO 38-10	1661520104	Nominal flow 10 l/min - 2.64 US gpm
VDR/CO 38-12	1661520105	Nominal flow 12 l/min - 3.2 US gpm
VDR/CO 38-14	1661520106	Nominal flow 14 l/min - 3.7 US gpm
VDR/CO 38-16	1661520107	Nominal flow 16 l/min - 4.2 US gpm
With G1/2 ports		
VDR/CO 12-12	1661530100	Nominal flow 12 l/min - 3.2 US gpm
VDR/CO 12-16	1661530101	Nominal flow 16 l/min - 4.2 US gpm
VDR/CO 12-20	1661530102	Nominal flow 20 l/min - 5.3 US gpm
VDR/CO 12-25	1661530103	Nominal flow 25 l/min - 6.6 US gpm
VDR/CO 12-30	1661530104	Nominal flow 30 l/min - 7.9 US gpm
VDR/CO 12-35	1661530105	Nominal flow 35 l/min - 9.3 US gpm
VDR/CO 12-40	1661530106	Nominal flow 40 l/min - 10.6 US gpm
VDR/CO 12-45	1661530107	Nominal flow 45 l/min - 11.9 US gpm

NOTE - l/min @ 50 bar - 720 psi

Rating diagrams

**VDR/CO 14 pressure drop vs. flow
(A→B)
B-C-D-E-F nominal flow**

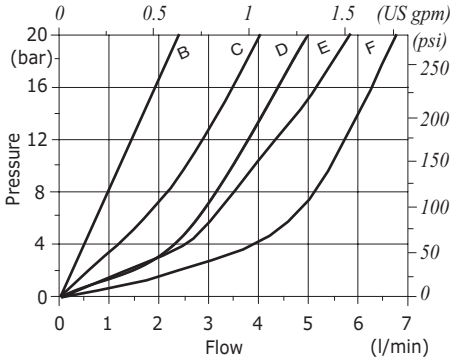

**VDR/CO 14 pressure drop vs. flow
(A→B)
G-H-I-L nominal flow**

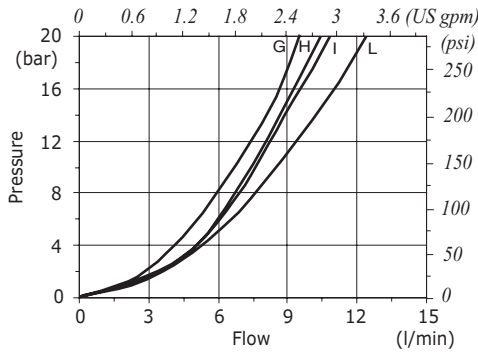

**VDR/CO 14 pressure drop vs. flow
(B→A)
compensation diagram**

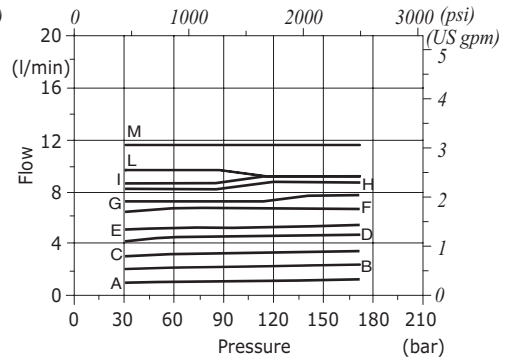

**VDR/CO 38 pressure drop vs. flow
(A→B)
B-C-D nominal flow**

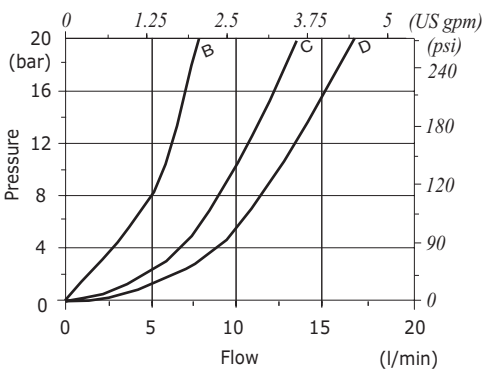

**VDR/CO 38 pressure drop vs. flow
(A→B)
E-F-I nominal flow**

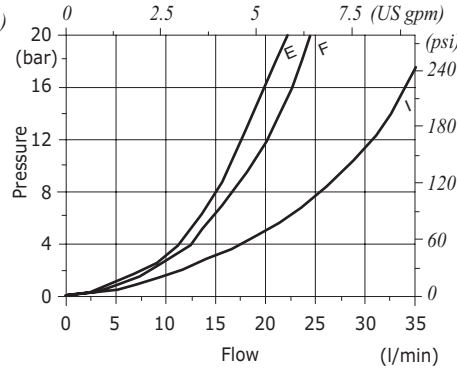

**VDR/CO 38 pressure drop vs. flow
(B→A)
compensation diagram**

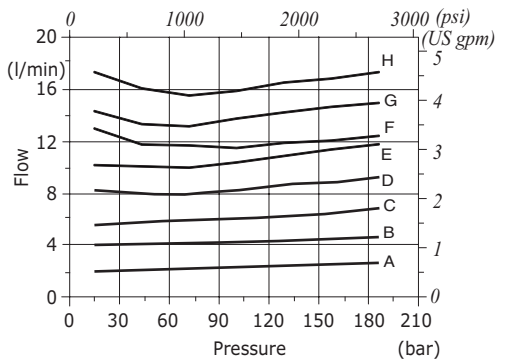

**VDR/CO 12 pressure drop vs. flow
(A→B)
A-B-C-D nominal flow**

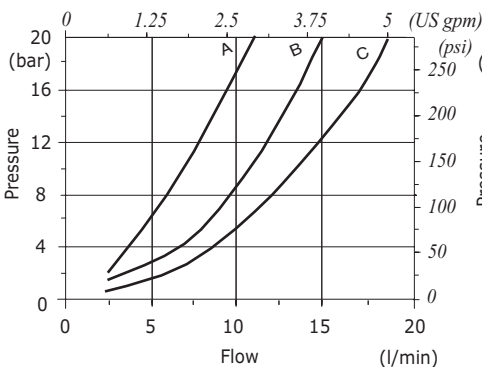

**VDR/CO 12 pressure drop vs. flow
(A→B)
E-F-I nominal flow**

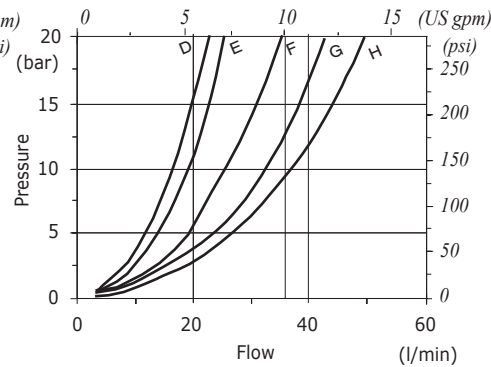

**VDR/CO 12 pressure drop vs. flow
(B→A)
compensation diagram**

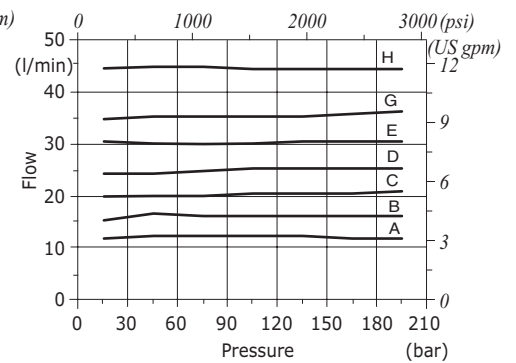



Type VSCOR.... flow control pressure compensated valves

- Pop-in cartridge compensated
- Flow regulator fixed type

Technical specifications and diagrams are measured with mineral oil of 46 cSt viscosity at 40°C (104°F) temperature.

VSCOR01..

Nominal flow from A to B	15 l/min (4.0 US gpm)
Nominal flow from B to A	10 l/min (2.6 US gpm)
Max. pressure	350 bar (5100 psi)
Fluid	mineral based oil
Viscosity	from 10 to 200 cSt
Max. level of contamination	18/16/13 ISO4406
Fluid temperature	with NBR seals from -20°C (-4°F) to 80°C (176°F)
Environmental temperature for working conditions	from -40°C (-40°F) to 100°C (212°F)
Weight	steel 0.014 kg (0.03 lb)

NOTE - For different conditions, please contact Walvoil Sales Dpt.

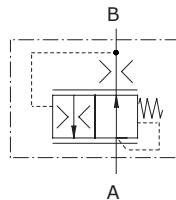

Ordering codes and description composition

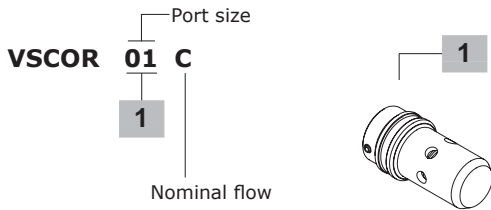

Nominal flow	
Type	VSCOR 01
	l/min - US gpm
A	1 - 0.26
B	2 - 0.53
C	3 - 0.79
D	4 - 1.06
E	5 - 1.32
F	6 - 1.58
G	7 - 1.85
H	8 - 2.11
I	9 - 2.38
L	10 - 2.64

Complete valves

TYPE	CODE	DESCRIPTION
With 01 port 12.7 mm (0.5 in)		
VSCOR01A	1662010100	Nominal flow type A
VSCOR01B	1662010101	Nominal flow type B
VSCOR01C	1662010102	Nominal flow type C

For different configurations or SAE thread please contact our Sales Dpt.

NOTE - l/min @ 50 bar - 720 psi

Dimension

VSCOR 01 pressure drop vs. flow (A→B)
B-C-D-E-F nominal flow

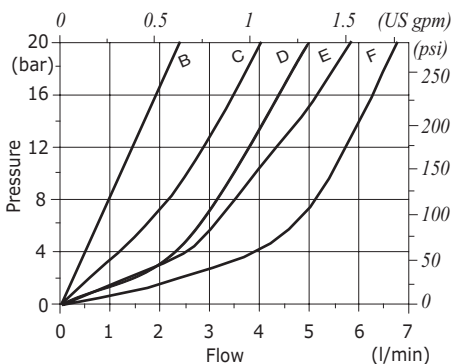

VSCOR 01 pressure drop vs. flow (A→B)
G-H-I-L nominal flow

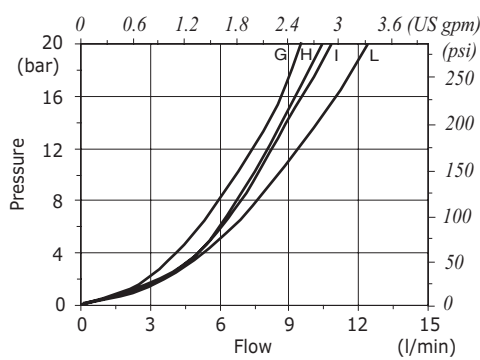

VSCOR 01 pressure drop vs. flow (B→A)
compensation diagram

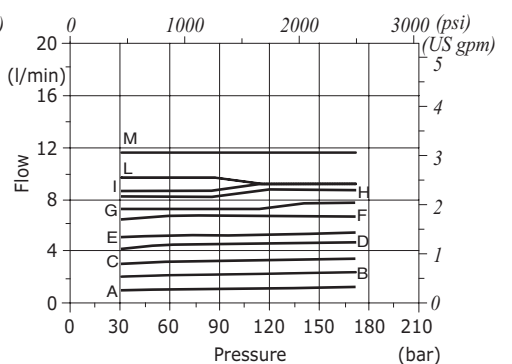



Type VDFR flow control pressure compensated valves

- Flow divider combiners

Technical specifications and diagrams are measured with mineral oil of 46 cSt viscosity at 40°C (104°F) temperature.

	VDFR 38-12	VDFR 38-24	VDFR 38-40	VDFR 12-12	VDFR 12-24	VDFR 12-40	VDFR 34-65	VDFR 34-90	VDFR 100-150	VDFR 114-250	
Nominal flow	l/min 4÷12 US gpm 1.1÷3.2	12÷24 3.2÷6.3	24÷38 6.3÷10.04	6.5÷12 1.71÷3.2	13÷23 3.43÷6.07	24÷40 6.3÷10.6	34÷65 8.98÷17.17	40÷90 10.6÷23.8	90÷150 23.8÷39.6	200÷250 52.8÷66	
Max. pressure	Aluminium body = 210 bar (3050 psi) Steel body = 350 bar (5100 psi)									Steel body = 350 bar (5100 psi)	
Maximum division error	± 5% of the oil flow in U1 or U2 and 120 bar (1750 psi) pressure difference between U1 and U2. (Division rate 50%÷50%)										
Fluid	mineral based oil										
Viscosity	from 10 to 200 cSt										
Max. level of contamination	18/16/13 ISO4406										
Fluid temperature	with NBR seals from -20°C (-4°F) to 80°C (176°F)										
Environmental temp. for working conditions	from -40°C (-40°F) to 100°C (212°F)										
Weight	alum.	0.82 kg (1.81 lb)	0.82 kg (1.81 lb)	0.87 kg (1.92 lb)	0.83 kg (1.83 lb)	0.83 kg (1.83 lb)	0.82 kg (1.81 lb)	0.92 kg (2.03 lb)	2.16 kg (4.76 lb)	2.09 kg (4.61 lb)	-
	steel	1.98 kg (4.37 lb)	1.98 kg (4.37 lb)	-	-	-	1.97 kg (4.34 lb)	-	4.42 kg (9.74 lb)	4.29 kg (9.46 lb)	6.58 kg (14.51 lb)

NOTE - For different conditions, please contact Walvoil Sales Dpt.

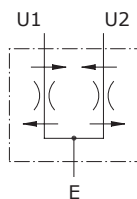

Dimensions

VDFR 38-12 - VDFR 38-24 - VDFR 12-40

These valves are supplied, as standard, without mounting holes.
Configurations with mounting holes (see dimension Q) are on request.

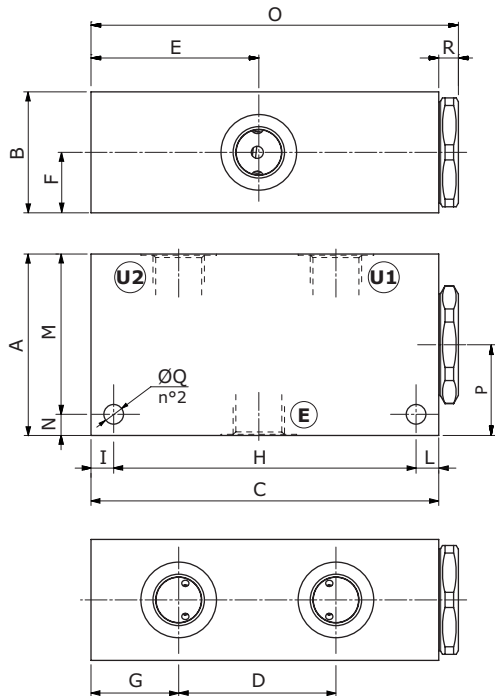

VDFR 34-65 - VDFR 34-90 - VDFR 100-150

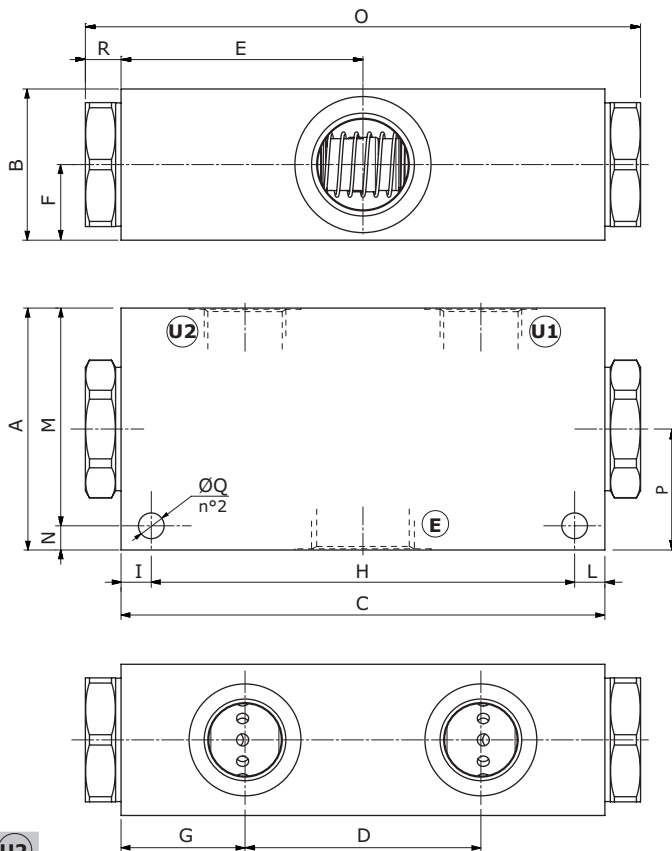

Valve type	E	U1 - U2	Valve type	E	U1 - U2
VDFR 38-12	G3/8	G3/8	VDFR 12-40	G1/2	G3/8
VDFR 38-24	G3/8	G3/8	VDFR 34-65	G3/4	G1/2
VDFR 38-40	G3/8	G3/8	VDFR 34-90	G3/4	G1/2
VDFR 12-12	G1/2	G3/8	VDFR 100-150	G1"	G3/4
VDFR 12-24	G1/2	G3/8	VDFR 114-250	G1"1/4	G1"

Valve type	E	U1 - U2
VDFR 38-12/SAE	SAE8	SAE8
VDFR 38-24/SAE	SAE8	SAE8
VDFR 12-40/SAE	SAE10	SAE8
VDFR 34-90/SAE	SAE12	SAE10
VDFR 100-150/SAE	SAE16	SAE12

VDFR 114-250

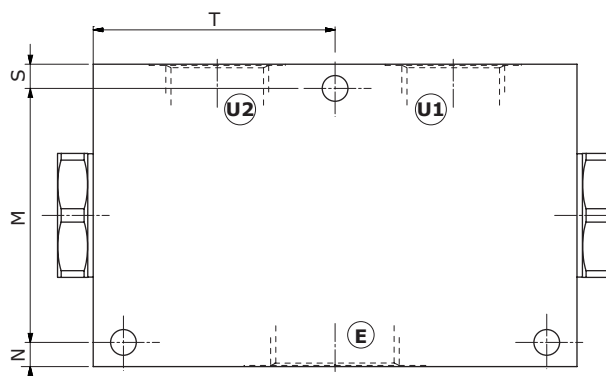

Dimensions are in mm-in

Valve type	A	B	C	D	E	F	G	H	I	L	M	N	O	P	ØQ	R	S	T
VDFR 38-12	60	40	115	52	55.5	20	29	100	7.5	7.5	53	7	121.5	30	6.5	6.5	-	-
VDFR 38-12/SAE	2.36	1.57	4.53	2.05	2.19	0.79	1.14	3.94	0.295	0.295	2.09	0.276	4.78	1.18	0.256	0.256	-	-
VDFR 38-24/38-40	60	40	115	52	55.5	20	29	100	7.5	7.5	53	7	121.5	30	6.5	6.5	-	-
VDFR 38-24/SAE	2.36	1.57	4.53	2.05	2.19	0.79	1.14	3.94	0.295	0.295	2.09	0.276	4.78	1.18	0.256	0.256	-	-
VDFR 12-12/12-24/12-40	60	40	115	52	55.5	20	29	100	7.5	7.5	53	7	121.5	30	6.5	6.5	-	-
VDFR 12-40/SAE	2.36	1.57	4.53	2.05	2.19	0.79	1.14	3.94	0.295	0.295	2.09	0.276	4.78	1.18	0.256	0.256	-	-
VDFR 34-65/34-90	80	50	160	78	80	25	41	140	10	10	72	8	183.6	40	8.5	11.8	-	-
VDFR 34-90/SAE	3.15	1.97	6.30	3.07	3.15	0.98	1.61	5.51	0.394	0.394	2.83	0.315	7.23	1.57	0.335	0.46	-	-
VDFR 100-150	80	50	160	78	80	25	41	140	10	10	72	8	183.6	40	8.5	11.8	-	-
VDFR 100-150/SAE	3.15	1.97	6.30	3.07	3.15	0.98	1.61	5.51	0.394	0.394	2.83	0.315	7.23	1.57	0.335	0.46	-	-
VDFR 114-250	100	60	160	78	80	30	41	140	10	10	84	8	183.6	50	8.5	11.8	8	80
	3.94	2.36	6.30	3.07	3.15	1.18	1.61	5.51	0.394	0.394	3.31	0.315	7.23	1.97	0.335	0.46	0.315	3.15

Flow control valves

Flow control pressure compensated valves

Ordering codes and description composition

Port size
VDFR 38-12

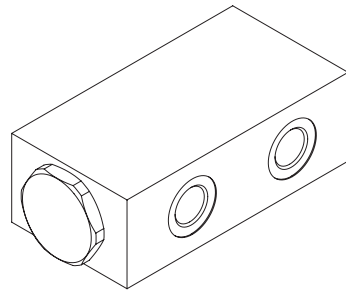

VDFR complete valves

50%-50% Divide ratio

TYPE	CODE	DESCRIPTION
VDFR 38-12	1650021100	Aluminium body, G3/8 ports
VDFR 38-24	1650021101	Aluminium body, G3/8 ports
VDFR 38-40	1650021137	Aluminium body, G3/8 ports
VDFR 12-12	1650031119	Aluminium body, G1/2 ports
VDFR 12-24	1650031120	Aluminium body, G1/2 ports
VDFR 12-40	1650031100	Aluminium body, G1/2 ports
VDFR 34-65	1650041107	Aluminium body, G3/4 ports
VDFR 34-90	1650041100	Aluminium body, G3/4 ports
VDFR 100-150	1650051100	Aluminium body, G1" ports
VDFR 38-12/ac	1650022100	Steel body, G3/8 ports
VDFR 38-24/ac	1650022101	Steel body, G3/8 ports

VDFR complete valves (continue)

50%-50% Divide ratio

TYPE	CODE	DESCRIPTION
VDFR 12-40/ac	1650032100	Steel body, G1/2 ports
VDFR 34-90/ac	1650042101	Steel body, G3/4 ports
VDFR 100-150/ac	1650052100	Steel body, G1" ports
VDFR 114-250/ac	1650062100	Steel body, G1 1/4 ports
VDFR 38-12/SAE	1650021202	Aluminium body, SAE8 ports
VDFR 38-24/SAE	1650021203	Aluminium body, SAE8 ports
VDFR 12-40/SAE	1650031201	Aluminium body, SAE10 ports
VDFR 34-90/SAE	1650041200	Aluminium body, SAE12 ports
VDFR 34-90/SAE/ac	1650042200	Steel body, SAE12 ports
VDFR 100-150/SAE/ac	1650052200	Steel body, SAE16 ports

Note: special divide ratios 33%÷66% - 30%÷70% - 20%÷80% - 25%÷75% - 40%÷60% for VDFR 38-12, 38-24, 12-40 and 34-90. 33%÷66%-40%÷60% for VDFR 100-150

For VDFR 114-250 please contact our Sales Dpt.

Mounting holes on request (standard on VDFR 34-90 - VDFR 100-150 and VDFR114-250)

For other steel body configurations, SAE thread and configurations with FPM (Viton) seals, please contact our Sales Dpt.

Rating diagrams

VDFR 38-12
pressure drop vs. flow
(E→U1-U2) and (U1-U2→E)

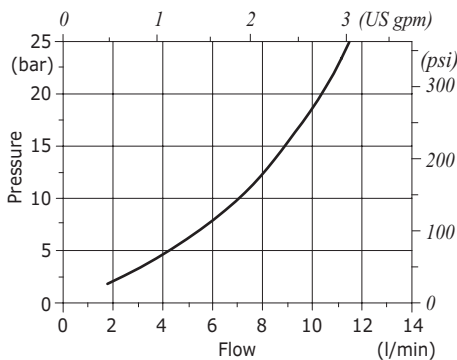

VDFR 38-24
pressure drop vs. flow
(E→U1-U2) and (U1-U2→E)

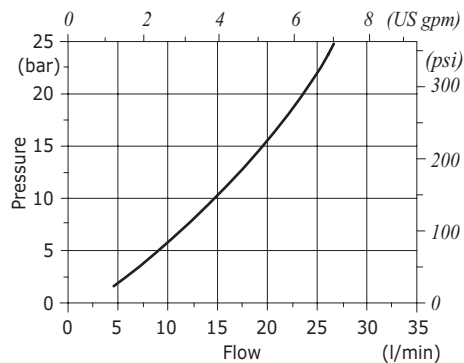

VDFR 38-40
pressure drop vs. flow
(E→U1-U2) and (U1-U2→E)

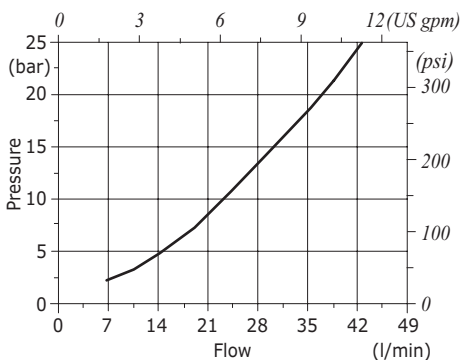

Rating diagrams

VDFR 12-12
pressure drop vs. flow
(E→U1-U2) and (U1-U2→E)

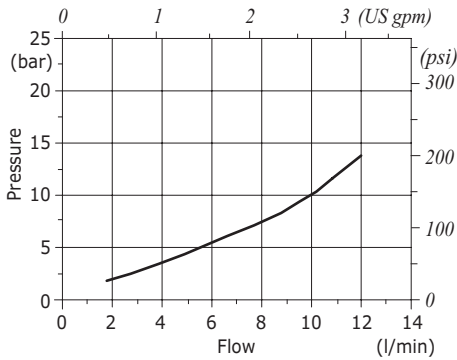

VDFR 12-24
pressure drop vs. flow
(E→U1-U2) and (U1-U2→E)

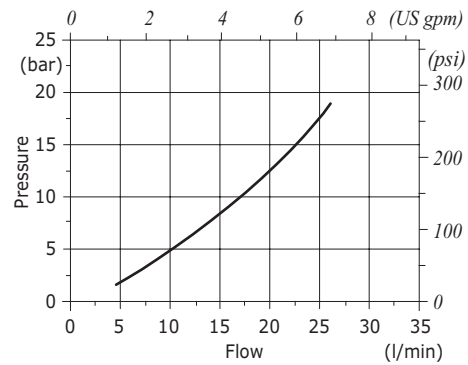

VDFR 12-40
pressure drop vs. flow
(E→U1-U2) and (U1-U2→E)

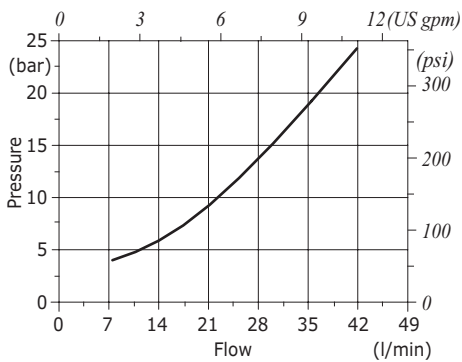

VDFR 34-65
pressure drop vs. flow
(E→U1-U2) and (U1-U2→E)

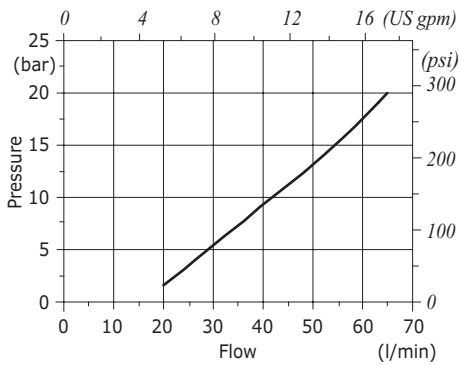

VDFR 34-90
pressure drop vs. flow
(E→U1-U2) and (U1-U2→E)

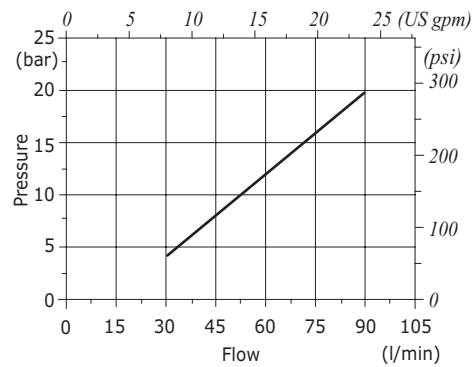

VDFR 100-150
pressure drop vs. flow
(E→U1-U2) and (U1-U2→E)

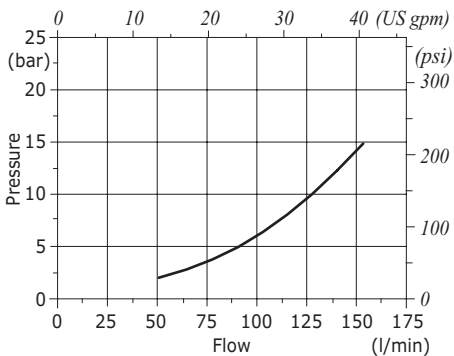

VDFR 114-250
pressure drop vs. flow
(E→U1-U2) and (U1-U2→E)

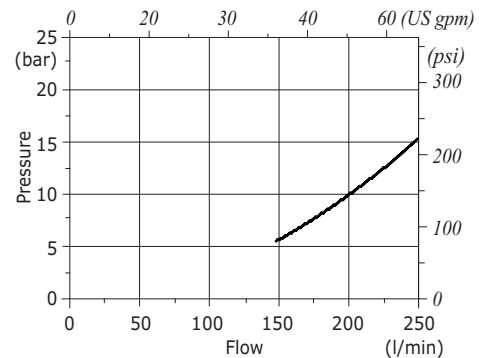

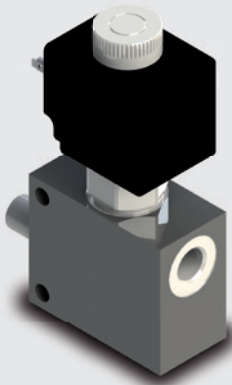

Type VE/B directional solenoid valves

- Two way
- With emergency
- Pilot operated

Technical specifications and diagrams are measured with mineral oil of 46 cSt viscosity at 40°C (104°F) temperature.

	VE/B 14	VE/B 38	VE/B 12	VE/B 34	VE/B 100	
Nominal flow	20 l/min (5.3 US gpm)	40 l/min (10.6 US gpm)	60 l/min (15.8 US gpm)	75 l/min (19.8 US gpm)	160 l/min (42.3 US gpm)	
Max. pressure	Aluminium body = 210 bar (3050 psi) Steel body = 350 bar (5100 psi)					
Oil leakage	0.25 cm ³ /min - 0.015 in ³ /min. (2 drops) at 210 bar - 3050 psi					
Fluid	mineral based oil					
Viscosity	from 10 to 200 cSt					
Max. level of contamination	18/16/13 ISO4406					
Fluid temperature	with NBR seals from -20°C (-4°F) to 80°C (176°F)					
Environmental temp. for working conditions	from -40°C (-40°F) to 100°C (212°F)					
Weight	<i>aluminium</i>	0.39 kg (0.86 lb)	0.39 kg (0.86 lb)	1.10 kg (2.43 lb)	1.08 kg (2.38 lb)	1.58 kg (3.48 lb)
	<i>steel</i>	0.77 kg (1.70 lb)	0.74 kg (1.63 lb)	1.93 kg (4.25 lb)	1.85 kg (4.08 lb)	2.90 kg (6.39 lb)

NOTE - For different conditions, please contact Walvoil Sales Dpt.

Normally closed configuration (NC)

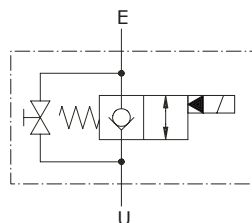

Normally open configuration (NA)

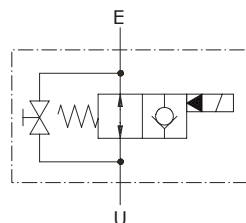

Dimensions

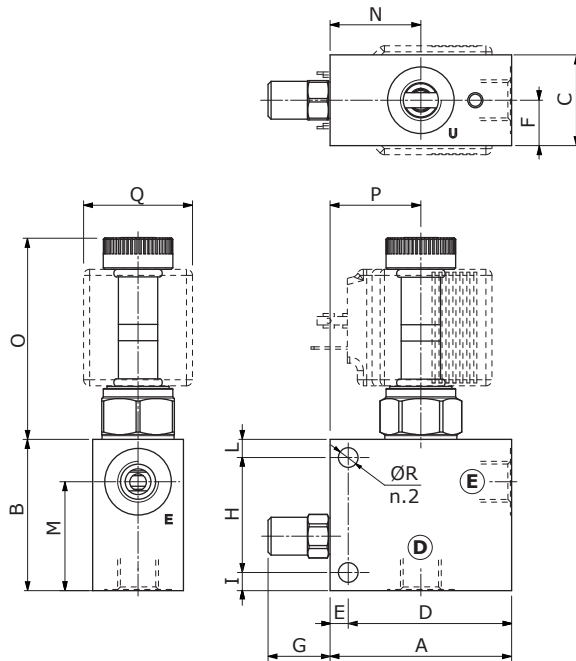

Valve type	U	E
VE/B 14	G1/4	G1/4
VE/B 38	G3/8	G3/8
VE/B 12	G1/2	G1/2
VE/B 34	G3/4	G3/4
VE/B 100	G1"	G1"

Dimensions are in mm-in

Valve type	A	B	C	D	E	F	G	H	I	L	M	N	O		P	Q	ØR
													(NA)	(NC)			
VE/B 14	60	50	30	54	6	15	20	38	6	6	36	30	66.7	62.8	30	36	6.5
	2.36	1.97	1.18	2.13	0.236	0.59	0.79	1.50	0.236	0.236	1.42	1.18	2.63	2.47	1.18	1.42	0.256
VE/B 38	60	50	30	54	6	15	20	38	6	6	36	30	66.7	62.8	30	36	6.5
	2.36	1.97	1.18	2.13	0.236	0.59	0.79	1.50	0.236	0.236	1.42	1.18	2.63	2.47	1.18	1.42	0.256
VE/B 12	80	65	40	74	6	20	23	53	6	6	43	40	86.4	81	40	36.5	6.5
	3.15	2.56	1.57	2.91	0.236	0.79	0.91	2.09	0.236	0.236	1.69	1.57	3.40	3.19	1.57	1.44	0.256
VE/B 34	80	65	40	74	6	20	23	53	6	6	43	40	86.4	81	40	36.5	6.5
	3.15	2.56	1.57	2.91	0.236	0.79	0.91	2.09	0.236	0.236	1.69	1.57	3.40	3.19	1.57	1.44	0.256
VE/B 100	90	80	50	82.5	7.5	25	23	65	7.5	7.5	49	43	79.4	74.2	43	36.5	8.5
	3.54	3.15	1.97	3.25	0.295	0.98	0.91	2.56	0.295	0.295	1.93	1.69	3.13	2.92	1.69	1.44	0.335

Ordering codes and description composition

Port size
VE/B 14/NA
 1

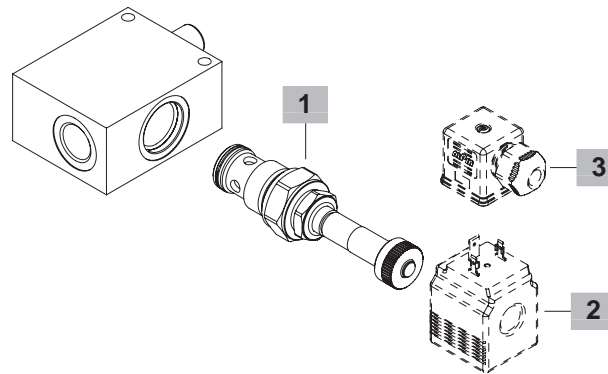

VE/B complete valves

TYPE	CODE	DESCRIPTION
(NA) normally open solenoid valve configuration		
VE/B 14/NA/EC08M	1720011101	Aluminium body, G1/4 ports
VE/B 38/NA/EC08M	1720021106	Aluminium body, G3/8 ports
VE/B 12/NA	1720031112	Aluminium body, G1/2 ports
VE/B 34/NA	1720041114	Aluminium body, G3/4 ports
VE/B 100/NA	1720051108	Aluminium body, G1" ports
VE/B 14/NA/ac	1720012101	Steel body, G1/4 ports
VE/B 38/NA/ac	1720022101	Steel body, G3/8 ports
VE/B 12/NA/ac	1720032104	Steel body, G1/2 ports
VE/B 34/NA/ac	1720042105	Steel body, G3/4 ports
VE/B 100/NA/ac	1720052109	Steel body, G1" ports
(NC) normally closed solenoid valve configuration		
VE/B 14/NC/EC08M	1720011100	Aluminium body, G1/4 ports
VE/B 38/NC/EC08M	1720021105	Aluminium body, G3/8 ports
VE/B 12/NC	1720031111	Aluminium body, G1/2 ports
VE/B 34/NC	1720041113	Aluminium body, G3/4 ports
VE/B 100/NC	1720051107	Aluminium body, G1" ports
VE/B 14/NC/ac	1720012100	Steel body, G1/4 ports
VE/B 38/NC/ac	1720022102	Steel body, G3/8 ports
VE/B 12/NC/ac	1720032103	Steel body, G1/2 ports
VE/B 34/NC/ac	1720042104	Steel body, G3/4 ports
VE/B 100/NC/ac	1720052108	Steel body, G1" ports

For other steel body configurations, SAE thread, other port sizes and configurations with FPM (Viton) seals, please contact our Sales Dpt.

1 Solenoid valve

TYPE	CODE	DESCRIPTION
(NA) normally open valve		
EC08M/10NB	0EC08002031	For VE/B 14 and VE/B 38 valves, BER coils required
EC10M/10NB	0EC10002012	For VE/B 12 and VE/B 34 valves, BER coils required
EC16M/10NB	0EC16002020	For VE/B 100 valve, BER coils required
(NC) normally closed valve		
EC08M/20NB	0EC08002032	For VE/B 14 and VE/B 38 valves, BER coils required
EC10M/20NB	0EC10002013	For VE/B 12 and VE/B 34 valves, BER coils required
EC16M/20NB	0EC16002021	For VE/B 100 valve, BER coils required

2 Coils

TYPE	CODE	DESCRIPTION
BER 12VDC	4SLE001200A	12VDC-ISO4400 coil, for EC08M valve
BT 12VDC	4SL3000120	12VDC-ISO4400 coil, for VSE/P/2 and VSE/P/2-150 valves

For complete coils list see from page 433

3 Connector

TYPE	CODE	DESCRIPTION
ISO4400	4CN1009995	Connector

For complete connectors list see from page 433

Rating diagrams

VE/B 14 pressure drop vs. flow from E→U

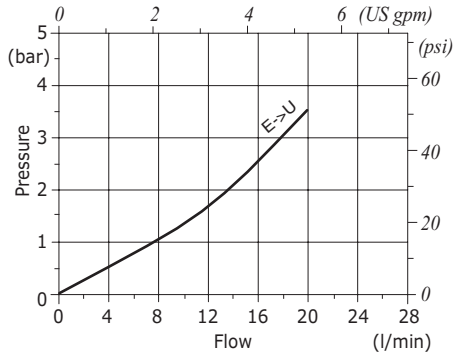

VE/B 38 pressure drop vs. flow from E→U and U→E

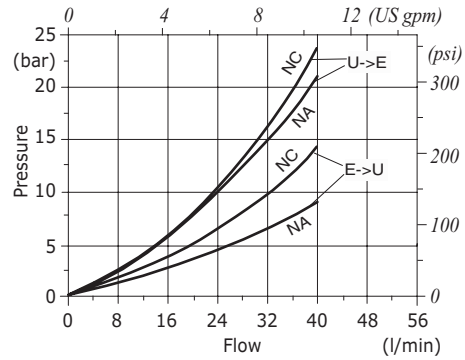

VE/B 12-34 pressure drop vs. flow from E→U and U→E

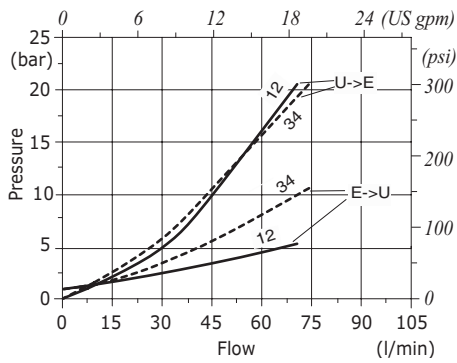

VE/B 100 pressure drop vs. flow from E→U and U→E

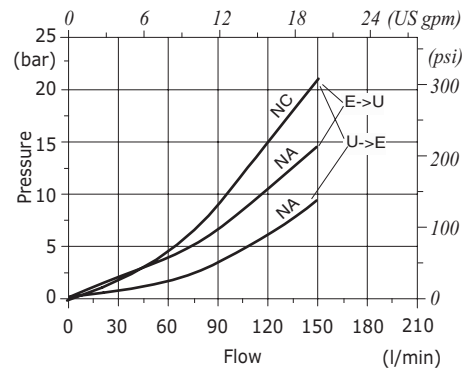

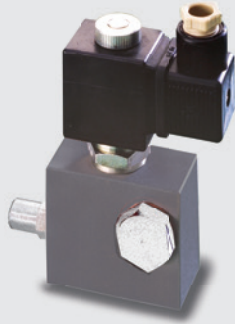

Type VE/B/RO directional solenoid valves

- Two way
- With emergency
- Pilot operated
- Bolt mounting

Technical specifications and diagrams are measured with mineral oil of 46 cSt viscosity at 40°C (104°F) temperature.

	VE/B/RO 14	VE/B/RO 38
Nominal flow	20 l/min (5.3 US gpm)	40 l/min (10.6 US gpm)
Max. pressure	Aluminium and steel body: 210 bar (3050 psi)	Aluminium body = 210 bar (3050 psi) Steel body = 350 bar (5100 psi)
Oil leakage	0.25 cm ³ /min - 0.015 in ³ /min. - 2 drops at 210 bar - 3050 psi	
Fluid	mineral based oil	
Viscosity	from 10 to 200 cSt	
Max. level of contamination	18/16/13 ISO4406	
Fluid temperature	with NBR seals from -20°C (-4°F) to 80°C (176°F)	
Environmental temp. for working conditions	from -40°C (-40°F) to 100°C (212°F)	
Weight	aluminium	0.41 kg (0.90 lb)
	steel	0.99 kg (2.18 lb)
		0.45 kg (0.99 lb)
		1.06 kg (2.34 lb)

NOTE - For different conditions, please contact Walvoil Sales Dpt.

Normally closed configuration (NC)

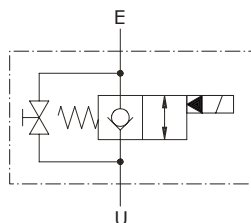

Normally open configuration (NA)

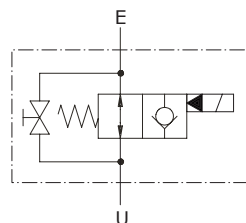

Dimensions

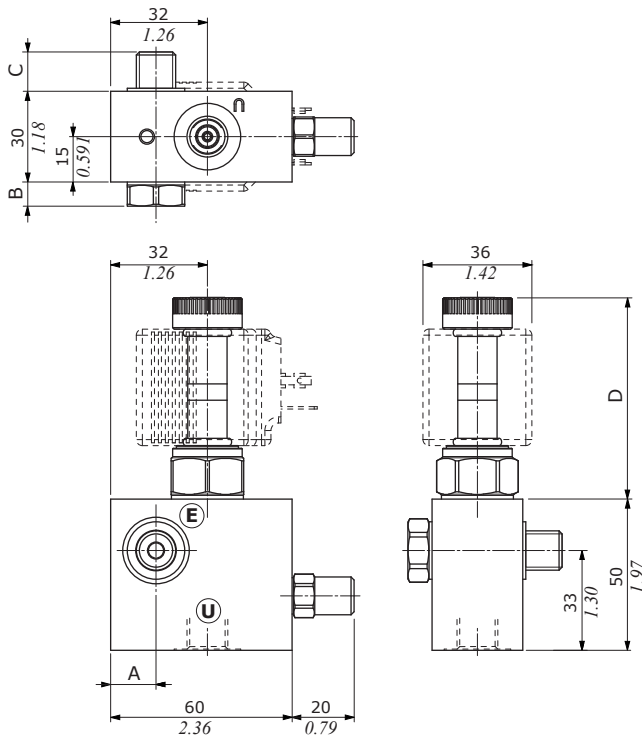

Valve type	U female	E male
VE/B 14	G1/4	G1/4
VE/B 38	G3/8	G3/8

Valve type	A	B	C	D	
				(NA)	(NC)
VE/B/RO 14	15	8	13	66.7	62.8
	0.591	0.315	0.512	2.63	2.47
VE/B/RO 38	14	9	14	66.7	62.8
	0.551	0.354	0.551	2.63	2.47

Ordering codes and description composition

Port size
VE/B/RO 14/NA
1

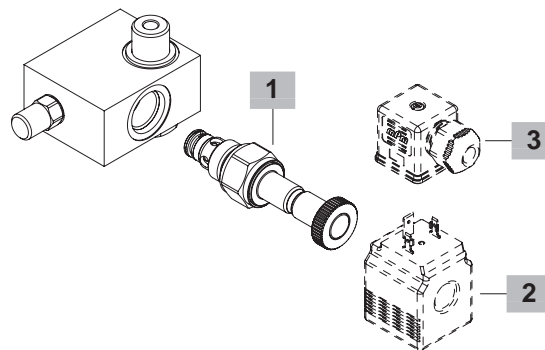

VE/B/RO complete valves

TYPE	CODE	DESCRIPTION
(NA) normally open solenoid valve configuration		
VE/B/RO 14/NA/EC08M	1722011101	Aluminium body, 1/4 ports
VE/B/RO 38/NA/EC08M	1722011103	Aluminium body, 3/8 ports
(NC) normally closed solenoid valve configuration		
VE/B/RO 14/NC/EC08M	1722011100	Aluminium body, 1/4 ports
VE/B/RO 38/NC/EC08M	1722021103	Aluminium body, 3/8 ports

For other steel body configurations, SAE thread, other port sizes and configurations with FPM (Viton) seals, please contact our Sales Dpt.

1 Solenoid valve

TYPE	CODE	DESCRIPTION
EC08M/10NB	0EC08002031	(NA) normally open configuration BER coils required
EC08M/20NB	0EC08002032	(NC) normally closed configuration BER coils required

2 Coils

TYPE	CODE	DESCRIPTION
BER 12VDC	4SLE001200A	12VDC-ISO4400 coil

For complete coils list see from page 433

3 Connector

TYPE	CODE	DESCRIPTION
ISO4400	4CN1009995	Connector

For complete connectors list see from page 433

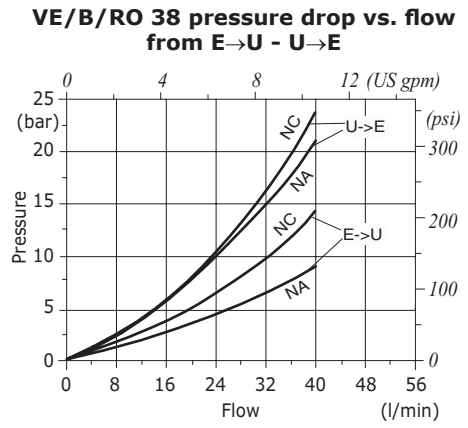
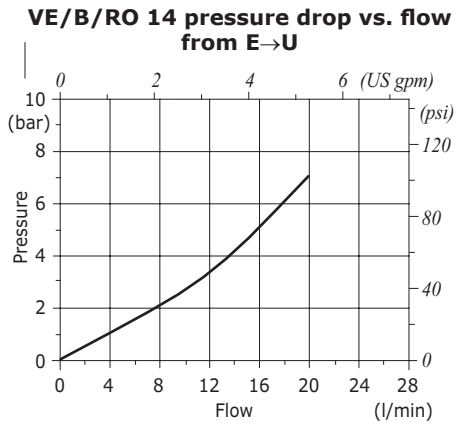



Type VE/B/VMP/VUI/SR directional solenoid valves

- Single acting cylinder

Technical specifications and diagrams are measured with mineral oil of 46 cSt viscosity at 40°C (104°F) temperature.

	VE/B/VMP/ VUI/SR 14	VE/B/VMP/ VUI/SR 38	VE/B/VMP/ VUI/SR 12	VE/B/VMP/ VUI/SR 34	VE/B/VMP/ VUI/SR 100	
Nominal flow	20 l/min (5.3 US gpm)	35 l/min (9.2 US gpm)	65 l/min (17.2 US gpm)	70 l/min (18.5 US gpm)	150 l/min (39.6 US gpm)	
Max. pressure	Aluminium body = 210 bar (3050 psi) Steel body = 350 bar (5100 psi)					
Oil leakage	0.25 cm ³ /min. - 0.015 in ³ /min. (5 drops) at 210 bar - 3050 psi					
Fluid	mineral based oil					
Viscosity	from 10 to 200 cSt					
Max. level of contamination	18/16/13 ISO4406					
Fluid temperature	with NBR seals from -20°C (-4°F) to 80°C (176°F)					
Environmental temp. for working conditions	from -40°C (-40°F) to 100°C (212°F)					
Weight	<i>aluminium</i>	1.32 kg (2.91 lb)	1.32 kg (2.91 lb)	3.01 kg (6.64 lb)	3.01 kg (6.64 lb)	5.00 kg (11.02 lb)
	<i>steel</i>	2.65 kg (5.84 lb)	2.65 kg (5.84 lb)	3.19 kg (7.03 lb)	3.19 kg (7.03 lb)	10.03 kg (22.11 lb)

NOTE - For different conditions, please contact Walvoil Sales Dpt.

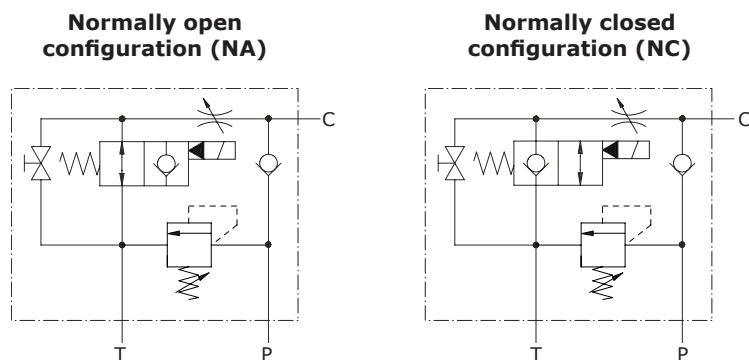

Dimensions

Valve type	All ports
VE/B/VMP/VUI/SR 14	G1/4
VE/B/VMP/VUI/SR 38	G3/8
VE/B/VMP/VUI/SR 12	G1/2
VE/B/VMP/VUI/SR 34	G3/4
VE/B/VMP/VUI/SR 100	G1"

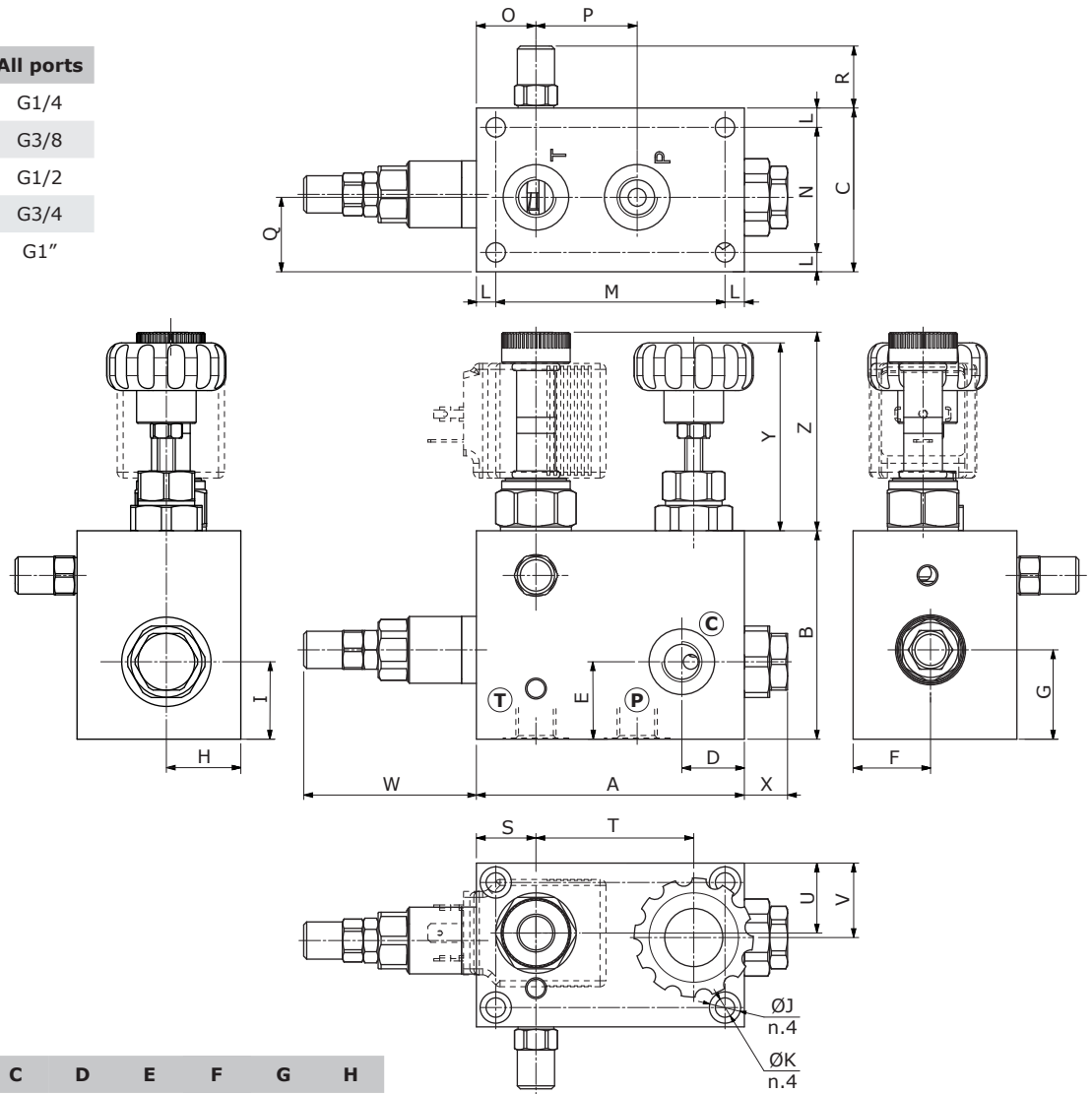

Dimensions are in mm-in

Valve type	A	B	C	D	E	F	G	H
VE/B/VMP/VUI/SR 14	90 3.54	70 2.76	55 2.17	21 0.83	26 1.02	26 1.02	30 1.18	25 0.98
VE/B/VMP/VUI/SR 38	90 3.54	70 2.76	55 2.17	22 0.87	26 1.02	26 1.02	30 1.18	25 0.98
VE/B/VMP/VUI/SR 12	115 4.53	100 3.94	70 2.76	28 1.10	38.5 1.53	32 1.26	38.5 1.53	32 1.26
VE/B/VMP/VUI/SR 34	115 4.53	100 3.94	70 2.76	30 1.18	38.5 1.53	32 1.26	38.5 1.53	32 1.26
VE/B/VMP/VUI/SR 100	150 5.91	120 4.72	80 3.15	37 1.46	45 1.77	36 1.42	45 1.77	36 1.42

Valve type	I	J	K	L	M	N	O	P	Q	R	S	T	U	V	W	X	Y	Z	
																		(NA)	(NC)
VE/B/VMP/VUI/SR 14	26 1.02	10.5 0.413	6.5 0.256	6.5 0.256	77 3.03	42 1.65	20 0.79	34 1.34	25 0.98	20.8 0.82	20 0.79	53 2.09	23.5 0.93	25 0.98	58 2.28	14.5 0.571	63 2.48	66.7 2.63	62.8 2.47
VE/B/VMP/VUI/SR 38	26 1.02	10.5 0.413	6.5 0.256	6.5 0.256	77 3.03	42 1.65	20 0.79	34 1.34	25 0.98	20.8 0.82	20 0.79	53 2.09	23.5 0.93	25 0.98	58 2.28	14.5 0.571	63 2.48	66.7 2.63	62.8 2.47
VE/B/VMP/VUI/SR 12	38.5 1.53	13.5 0.531	8.5 0.335	8.5 0.335	98 3.86	53 2.09	29 1.14	37 1.46	29 1.14	23.8 0.94	29 1.14	61 2.40	29 1.14	29 1.14	56.5 2.22	11 0.433	72.5 2.85	86.4 3.40	81 3.19
VE/B/VMP/VUI/SR 34	38.5 1.53	13.5 0.531	8.5 0.335	8.5 0.335	98 3.86	53 2.09	29 1.14	41 1.61	29 1.14	23.5 0.93	29 1.14	61 2.40	29 1.14	29 1.14	56.5 2.22	11 0.433	72.5 2.85	86.4 3.40	81 3.19
VE/B/VMP/VUI/SR 100	45 1.77	16.5 0.65	10.5 0.413	10 0.394	130 5.12	60 2.36	27 1.06	60 2.36	36 1.42	23.5 0.93	27 1.06	91 3.58	36 1.42	36 1.42	71 2.80	16.5 0.65	83 3.27	79.4 3.13	74.2 2.92

Ordering codes and description composition

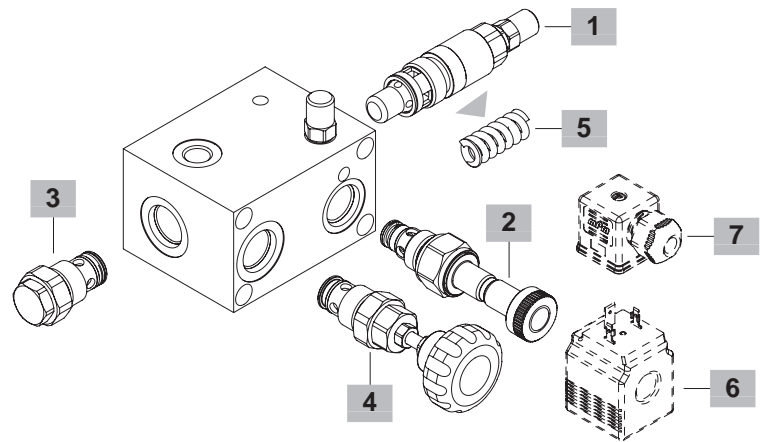
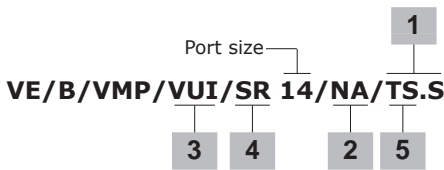

VE/B/VMP/VUI/SR complete valves

Aluminium body and VMP direct type valve configuration
 Standard setting 160 bar at 5 l/min (2320 psi at 1.32 US gpm)
 Setting range: 50-220 bar (725-3200 psi)

TYPE	CODE	DESCRIPTION
(NA) normally open solenoid valve configuration		
VE/B/VMP/VUI/SR 14/NA/TS.S	1900511101	G1/4 ports
VE/B/VMP/VUI/SR 38/NA/TS.S	1900521103	G3/8 ports
VE/B/VMP/VUI/SR 12/NA/TS.S	1900531110	G1/2 ports
VE/B/VMP/VUI/SR 34/NA/TS.S	1900541106	G3/4 ports
VE/B/VMP/VUI/SR 100/NA/TS.S	1900551110	G1" ports
(NC) normally closed solenoid valve configuration		
VE/B/VMP/VUI/SR 14/NC/TS.S	1900511100	G1/4 ports
VE/B/VMP/VUI/SR 38/NC/TS.S	1900521102	G3/8 ports
VE/B/VMP/VUI/SR 12/NC/TS.S	1900531109	G1/2 ports
VE/B/VMP/VUI/SR 34/NC/TS.S	1900541105	G3/4 ports
VE/B/VMP/VUI/SR 100/NC/TS.S	1900551109	G1" ports
VE/B/VMP/VUI/SR 38/NC/TS.S/SAE	1900521200	SAE8 ports
VE/B/VMP/VUI/SR 12/NC/TS.S/SAE	1900531200	SAE10 ports

For other steel body configurations, SAE thread, other port sizes and configurations with FPM (Viton) seals, please contact our Sales Dpt.

1 Pressure relief valve

TYPE	CODE	DESCRIPTION
For VE/B/VMP/VUI/SR 14 and 38 valves		
VMP 5/TS.S	1100520400	Setting range 50-220 bar (725-3200 psi)
For VE/B/VMP/VUI/SR 12 and 34 valves		
VMP 10/TS.S	1100530400	Setting range 50-220 bar (725-3200 psi)
For VE/B/VMP/VUI/SR 100 valve		
VMP 20/TS.S	1100540400	Setting range 50-220 bar (725-3200 psi)

2 Solenoid valve

TYPE	CODE	DESCRIPTION
For VE/B/VMP/VUI/SR 14 and 38 valves: BER coils required		
EC08M/10NB	0EC08002031	(NA) normally open configuration
EC08M/20NB	0EC08002032	(NC) normally closed configuration
For VE/B/VMP/VUI/SR 12 and 34 valves: BER coils required		
EC10M/10NB	0EC10002012	(NA) normally open configuration
EC10M/20NB	0EC10002013	(NC) normally closed configuration
For VE/B/VMP/VUI/SR 100 valve: BER coils required		
EC16M/10NB	0EC16002020	(NA) normally open configuration
EC16M/20NB	0EC16002021	(NC) normally closed configuration

3 Check valve

TYPE	CODE	DESCRIPTION
For VE/B/VMP/VUI/SR 14 and 38 valves		
VUI 38/Pa0,5	1300020400	Opening pressure 0.5 bar (7.25 psi)
For VE/B/VMP/VUI/SR 12 and 34 valves		
VUI 12/Pa0,5	1300030400	Opening pressure 0.5 bar (7.25 psi)
For VE/B/VMP/VUI/SR 100 valve		
VUI 34/Pa0,5 pasmag	1300020400	Opening pressure 0.5 bar (7.25 psi)

4 Needle valve

TYPE	CODE	DESCRIPTION
For VE/B/VMP/VUI/SR 14 and 38 valves		
VUI/SR 38/V	1305020400	Handknob actuation
For VE/B/VMP/VUI/SR 12 and 34 valves		
VUI/SR 12/V	1305030400	Handknob actuation
For VE/B/VMP/VUI/SR 100 valve		
VUI/SR 34/V	1305040400	Handknob actuation

5 Pressure setting springs

TYPE	CODE	DESCRIPTION
For VE/B/VMP/VUI/SR 14 and 38 valves		
TB	3MOL314311	Setting range 5-40 bar (72.5-580 psi)
TV	3MOL314330	Setting range 20-80 bar (290-1150 psi)
TS	3MOL315330	Setting range 50-220 bar (725-3200 psi)
TR	3ML1143600	Setting range 180-350 bar (2600-5075 psi)
For VE/B/VMP/VUI/SR 12 and 34 valves		
TB	3MOL316410	Setting range 5-40 bar (72.5-580 psi)
TV	3ML1154300	Setting range 20-80 bar (290-1150 psi)
TS	3MOL317420	Setting range 50-220 bar (725-3200 psi)
TR	3MOL317440	Setting range 180-350 bar (2600-5075 psi)
For VE/B/VMP/VUI/SR 100 valve		
TB	3ML1184300	Setting range 5-40 bar (72.5-580 psi)
TV	3ML1174500	Setting range 20-80 bar (290-1150 psi)
TS	3ML1204200	Setting range 50-220 bar (725-3200 psi)
TR	3ML1214500	Setting range 180-350 bar (2600-5075 psi)

6 Coils

TYPE	CODE	DESCRIPTION
BER 12VDC	4SLE001200A	12VDC-ISO4400 for EC08M
BT 12VDC	4SL3000120	12VDC-ISO4400 for VSE/P/2 and VSE/P/2-150

For complete coils list see from page 433

7 Connector

TYPE	CODE	DESCRIPTION
ISO4400	4CN1009995	Connector

For complete connectors list see from page 433

Rating diagrams

VE/B/VMP/VUI/SR 14 pressure drop vs. flow from P→C - C→T

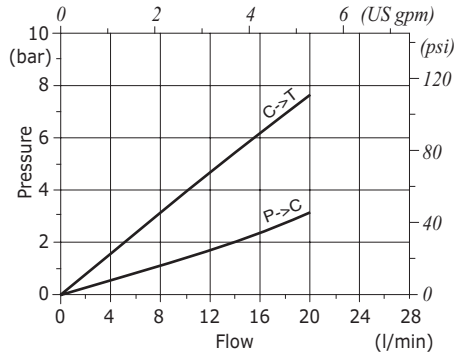

VE/B/VMP/VUI/SR 38 pressure drop vs. flow from P→C - C→T

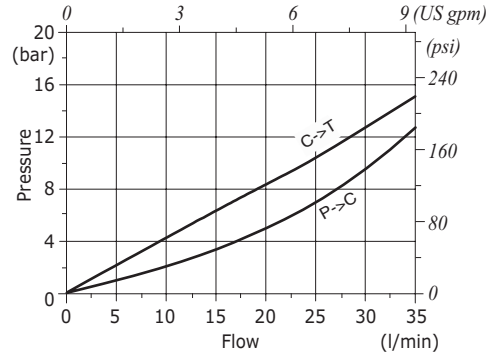

VE/B/VMP/VUI/SR (12-34) pressure drop vs. flow from P→C - C→T

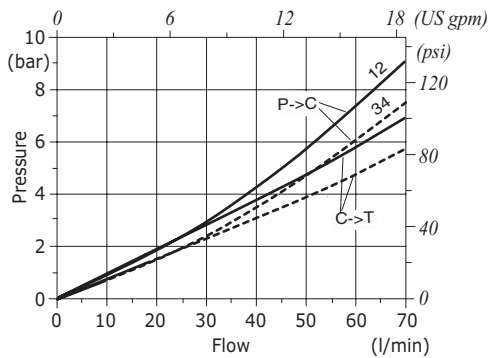

VE/B/VMP/VUI/SR 100 pressure drop vs. flow from P→C - C→T

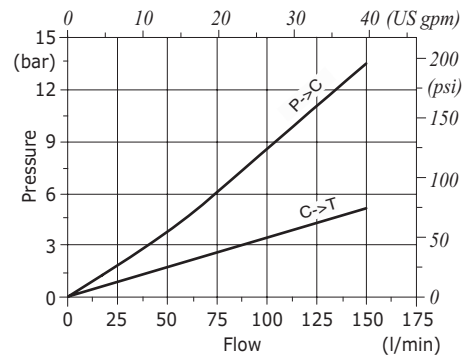

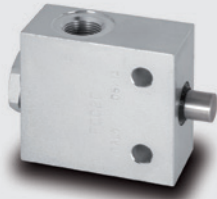

Type FCS..C / FC..C End stroke valves

- Normally closed
- FC..C double lock

Technical specifications and diagrams are measured with mineral oil of 46 cSt viscosity at 40°C (104°F) temperature.

	FCS02C	FCS03C	FC02C	FC03C
Max. flow	30 l/min (7.9 US gpm)	60 l/min (15.9 US gpm)	30 l/min (7.9 US gpm)	60 l/min (15.9 US gpm)
Max. pressure	300 bar (4350 psi)			
Fluid	mineral based oil			
Max. stroke	10 mm (0.39 in)	12 mm (0.47 in)	10 mm (0.39 in)	12 mm (0.47 in)
Spring force	40 N (9 lbf)		100 N (22.48 lbf)	
Viscosity	from 10 to 200 cSt			
Max. level of contamination	18/16/13 ISO4406			
Fluid temperature	with NBR seals from -20°C (-4°F) to 80°C (176°F)			
Environmental temperature for working conditions	from -40°C (-40°F) to 100°C (212°F)			
Weight	steel 0.79 kg (1.74 lb)	1.28 kg (2.82 lb)	0.79 kg (1.74 lb)	1.30 kg (2.87 lb)

NOTE - For different conditions, please contact Walvoil Sales Dpt.

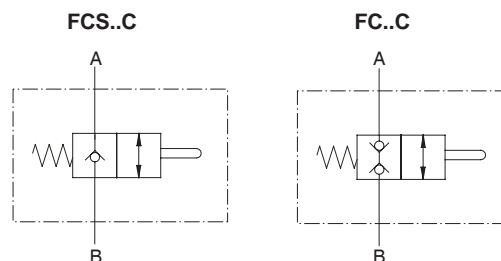

Dimensions

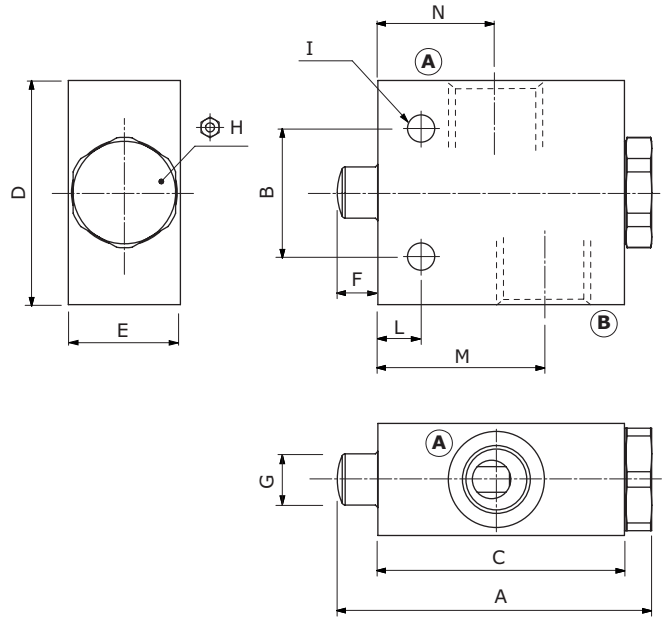

Valve type	(A) (B)
FCS02C	G3/8
FCS03C	G1/2

Dimensions are in mm-in

Valve type	A	B	C	D	E	F	G	⌀H	I	L	M	N
FCS02C	83 3.27	35 1.38	65 2.56	60 2.36	30 1.18	10 0.39	8 0.31	27	8.5 0.33	13.5 0.53	43 1.69	30 1.18
FCS03C	103 4.05	40 1.57	80 3.15	75 2.95	35 1.38	13 0.51	12 0.47	32	10.5 0.41	13.5 0.53	51 2.01	37 1.46

Valve type	(A) (B)
FC02C	G3/8
FC03C	G1/2

Dimensions are in mm-in

Valve type	A	B	C	D	E	F	G	⌀H	I	L	M	N
FC02C	83 3.27	35 1.38	65 2.56	60 2.36	30 1.18	10 0.39	12 0.47	27	8.5 0.33	13.5 0.53	43 1.69	30 1.18
FC03C	103 4.05	40 1.57	80 3.15	75 2.95	35 1.38	13 0.51	16 0.63	32	10.5 0.41	13.5 0.53	51 2.01	37 1.46

Ordering codes and description composition

FC 03 C
Port size

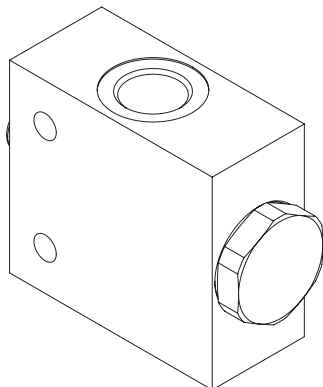

FC-C complete valves

TYPE	CODE	DESCRIPTION
FCS02C	1419622100	Steel body, G3/8 ports
FCS03C	1419632100	Steel body, G1/2 ports
FC02C	1419722100	Steel body, G3/8 ports
FC03C	1419732100	Steel body, G1/2 ports

For SAE thread, please contact our Sales Dpt.



Type FC..A End stroke valves

- Normally open

Technical specifications and diagrams are measured with mineral oil of 46 cSt viscosity at 40°C (104°F) temperature.

	FC02A	FC03A
Max. flow	30 l/min (7.9 US gpm)	60 l/min (15.9 US gpm)
Max. pressure	300 bar (4350 psi)	
Fluid	mineral based oil	
Max. stroke	7 mm (0.27 in)	7 mm (0.27 in)
Spring force	100 N (22.48 lbf)	
Viscosity	from 10 to 200 cSt	
Max. level of contamination	18/16/13 ISO4406	
Fluid temperature	with NBR seals from -30°C (-22°F) to 100°C (212°F)	
Environmental temperature for working conditions	from -40°C (-40°F) to 100°C (212°F)	
Weight	steel 0.75 kg (1.65 lb)	0.77 kg (1.70 lb)

NOTE - For different conditions, please contact Walvoil Sales Dpt.

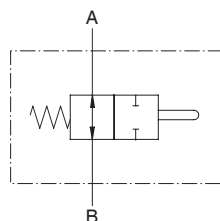

Dimensions

FC02A - FC03A

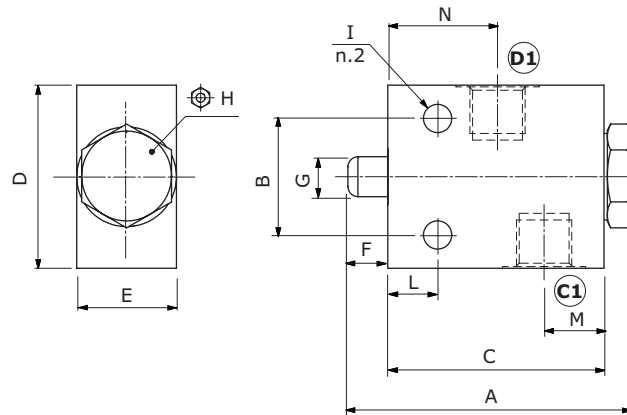

Valve type	(A)	(B)
FC02A	G3/8	
FC03A	G1/2	

Dimensions are in mm-in

Valve type	A	B	C	D	E	F	G	$\varnothing H$	I	L	M	N
FC02A	81.5 3.21	40 1.57	65 2.56	60 2.36	30 1.18	12 0.47	14 0.55	27	8.5 0.33	15 0.59	17 0.67	28 1.1
FC03A	81.5 3.21	40 1.57	65 2.56	60 2.36	30 1.18	12 0.47	14 0.55	27	8.5 0.33	15 0.59	17 0.67	28 1.1

Ordering codes and description composition

FC 03 A
Port size

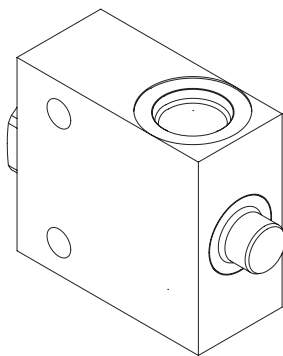

FC..A Complete valves

TYPE	CODE	DESCRIPTION
FC02A	1419822101	Steel body, G3/8 ports
FC03A	1419832100	Steel body, G1/2 ports

For SAE thread, please contact our Sales Dpt.



Type VDA unloader valves

- Single acting
- Built-in check

Technical specifications and diagrams are measured with mineral oil of 46 cSt viscosity at 40°C (104°F) temperature.

	VDA 38	VDA 12	VDA 34	
Nominal flow	25 l/min (6.6 US gpm)	50 l/min (13.2 US gpm)	100 l/min (26.4 US gpm)	
Max. pressure		Aluminium body = 210 bar (3050 psi) Steel body = 350 bar (5100 psi)		
Fluid		mineral based oil		
Viscosity		from 10 to 200 cSt		
Max. level of contamination		18/16/13 ISO4406		
Fluid temperature		with NBR seals from -20°C (-4°F) to 80°C (176°F)		
Environmental temp. for working conditions		from -40°C (-40°F) to 100°C (212°F)		
Weight	aluminium	2.15 kg (4.73 lb)	2.35 kg (5.18 lb)	3.24 kg (7.14 lb)
	steel	5.05 kg (12.13 lb)	5.57 kg (12.28 lb)	8.10 kg (17.86 lb)

NOTE - For different conditions, please contact Walvoil Sales Dpt.

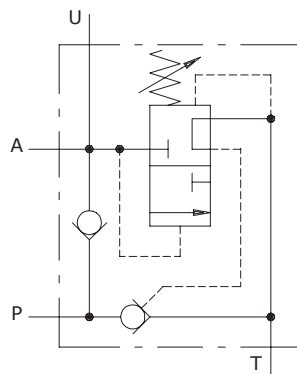

Dimensions

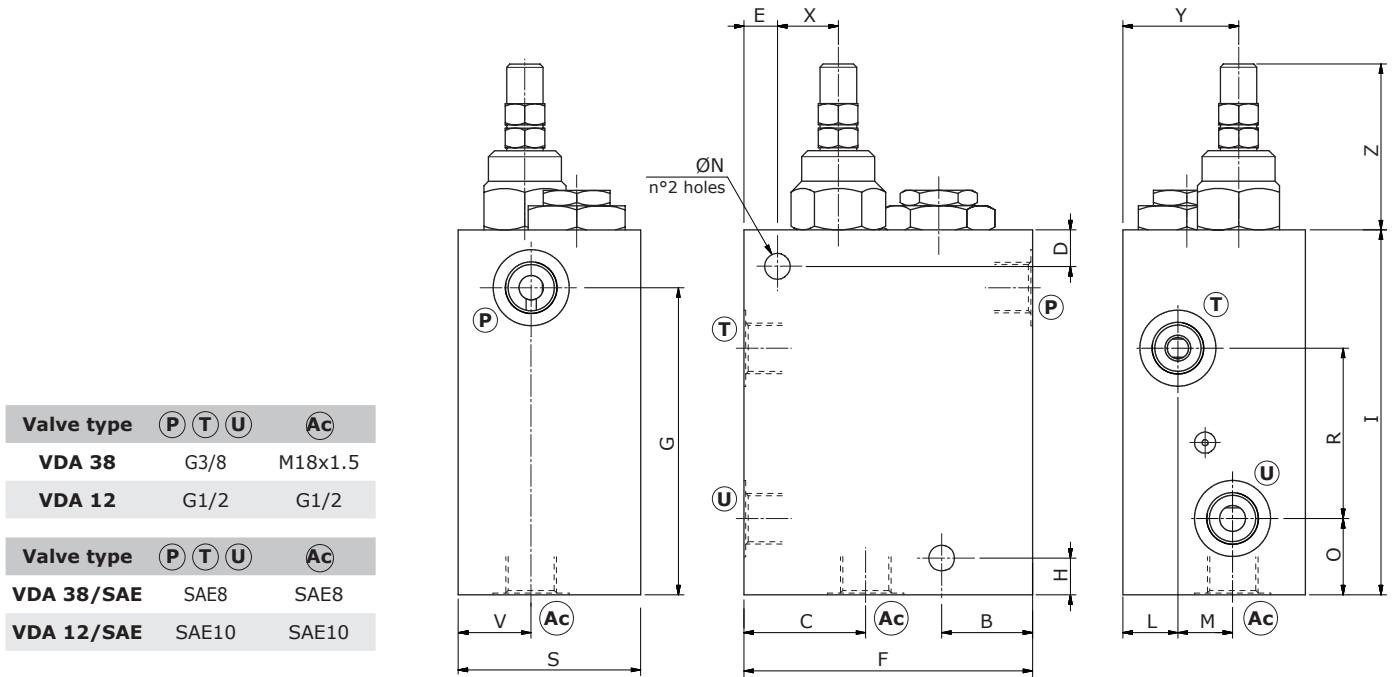

Valve type	P	T	U	Ac
VDA 38	G3/8			M18x1.5
VDA 12	G1/2			G1/2

Valve type	P	T	U	Ac
VDA 38/SAE	SAE8			SAE8
VDA 12/SAE	SAE10			SAE10

Dimensions are in mm-in

Valve type	B	C	D	E	F	G	H	I	L	M	$\varnothing N$	O	R	S	V	X	Y	Z
VDA 38 VDA 38/SAE	30-1.18	40-1.57	12-0.47	11-0.43	95-3.74	101-3.98	12-0.47	120-4.72	18-0.71	18-0.71	8.5-0.33	25-0.98	56-2.20	60-2.36	24-0.94	20-0.79	38-1.50	56-2.20
VDA 12 VDA 12/SAE	42-1.65	42-1.65	13-0.51	12-0.47	108-4.25	101-3.98	11-0.43	120-4.72	19-0.75	11-0.43	8.5-0.33	25-0.98	56-2.20	60-2.36	23-0.91	22-0.87	38-1.50	56-2.20

Valve type	P	T	U	Ac
VDA 34	G3/4			G1/2

Valve type	P	T	U	Ac
VDA 34/SAE	SAE12			SAE10

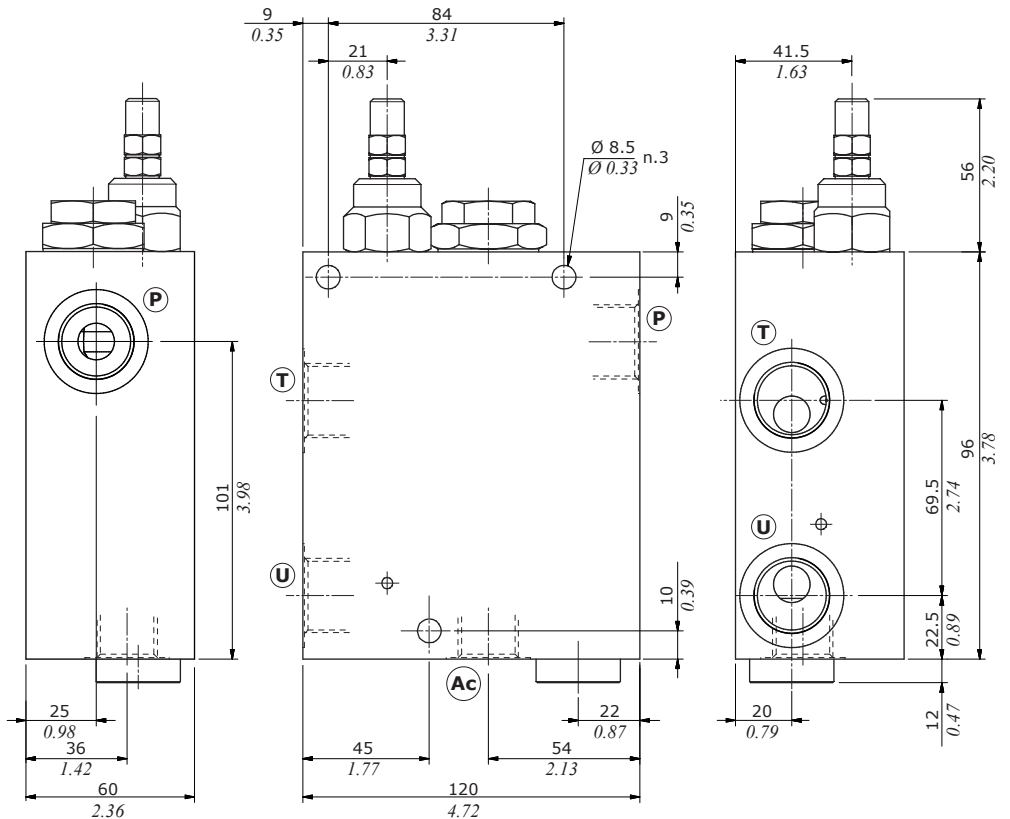

Ordering codes and description composition

Port size
VDA 38/TR.S.VRR
1

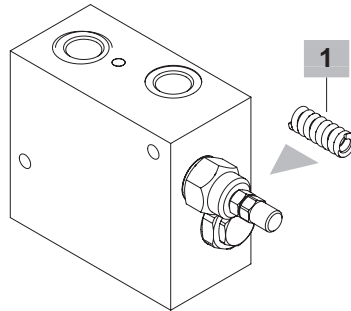

VDA complete valves

Single type valve configuration

Standard setting 200 bar at 5 l/min (2900 psi at 1.32 US gpm)

Standard differential pressure 15%

TYPE	CODE	DESCRIPTION
------	------	-------------

Configuration with G3/8 standard thread

VDA 38/TR.S.VRR	1210021101	Aluminium body, setting range 100-250 bar (1450-3600 psi)
VDA 38/DR/TR.S.VRR	1210021113	As previous one, with Drain port
VDA 38/TR.S.VRR/ac	1210022101	Steel body, setting range 100-250 bar (1450-3600 psi)

Configuration with G1/2 standard thread

VDA 12/TR.S.VRR	1210031101	Aluminium body, setting range 100-250 bar (1450-3600 psi)
VDA 12/DR/TR.S.VRR	1210031104	As previous one, with Drain port
VDA 12/TR.S.VRR/ac	1210032101	Steel body, setting range 100-250 bar (1450-3600 psi)

Configuration with G3/4 standard thread

VDA 34/TR.S.VRR	1210041101	Aluminium body, setting range 100-250 bar (1450-3600 psi)
VDA 34/DR/TR.S.VRR	1210041108	As previous one, with Drain port
VDA 34/TR.S.VRR/ac	1210042100	Steel body, setting range 100-250 bar (1450-3600 psi)

Configuration with SAE8 standard thread

VDA 38/TR.S.VRR/SAE	1210021200	Aluminium body, setting range 100-250 bar (1450-3600 psi)
----------------------------	------------	---

Configuration with SAE10 standard thread

VDA 12/TR.S.VRR/SAE	1210031200	Aluminium body, setting range 100-250 bar (1450-3600 psi)
VDA 12/TR.S.VRR/ac/SAE	1210032102	Steel body, setting range 100-250 bar (1450-3600 psi)

Configuration with SAE12 standard thread

VDA 34/TR.S.VRR/SAE	1210041200	Aluminium body, setting range 100-250 bar (1450-3600 psi)
VDA 34/TR.S.VRR/ac/SAE	1210042200	Steel body, setting range 100-250 bar (1450-3600 psi)

For other steel body configurations, SAE thread and configurations with FPM (Viton) seals, contact our Sales Dpt.

1 Pressure setting springs

TYPE	CODE	DESCRIPTION
TV	3ML1164000	Setting range 5-110 bar (72.5-1600 psi)
TR	3ML1164001	Setting range 100-250 bar (1450-3600 psi)

Rating diagrams

VDA 38 P→T pressure drop vs. flow

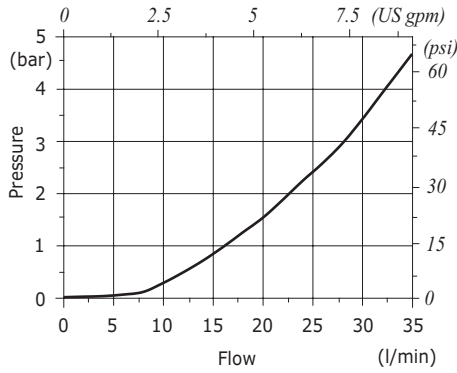

VDA 38 P→U pressure drop vs. flow

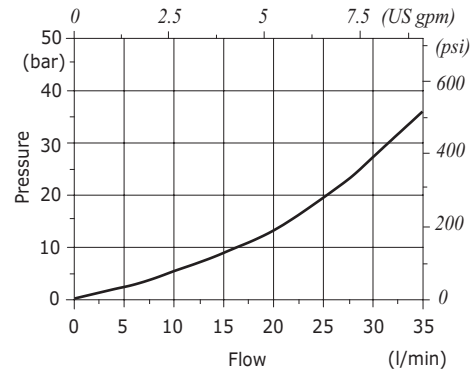

VDA 12 and VDA 12/DR pressure drop vs. flow

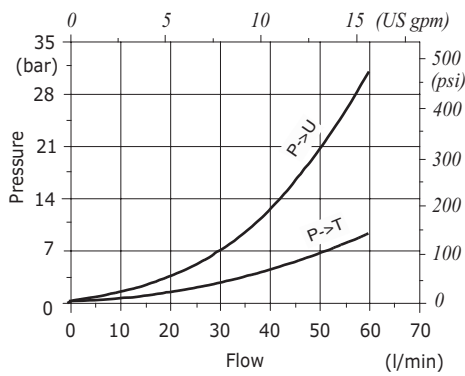

VDA 34 pressure drop vs. flow

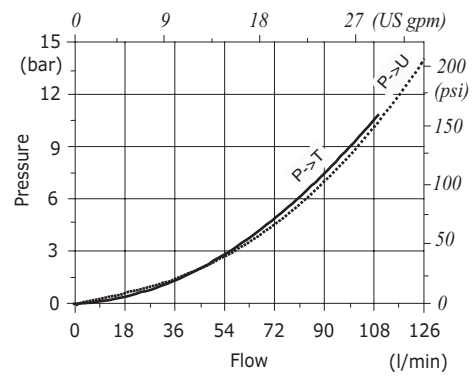



Type VDA/FL unloader valves

- Face mounting cetop 3 (6-38) or cetop 5 (10-12)
- Built-in check

Technical specifications and diagrams are measured with mineral oil of 46 cSt viscosity at 40°C (104°F) temperature.

	VDA/FL 38	VDA/FL 12
Nominal flow	25 l/min (6.6 US gpm)	50 l/min (13.2 US gpm)
Max. pressure	Aluminium body = 210 bar (3050 psi) Steel body = 350 bar (5100 psi)	
Fluid	mineral based oil	
Viscosity	from 10 to 200 cSt	
Max. level of contamination	18/16/13 ISO4406	
Fluid temperature	with NBR seals from -20°C (-4°F) to 80°C (176°F)	
Environmental temp. for working conditions	from -40°C (-40°F) to 100°C (212°F)	
Weight	aluminium	2.43 kg (5.35 lb)
	steel	6 kg (13.23 lb)
		2.80 kg (6.17 lb)
		7.05 kg (15.54 lb)

NOTE - For different conditions, please contact Walvoil Sales Dpt.

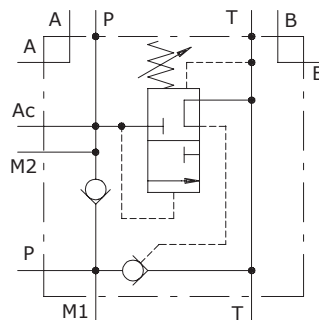

Dimensions

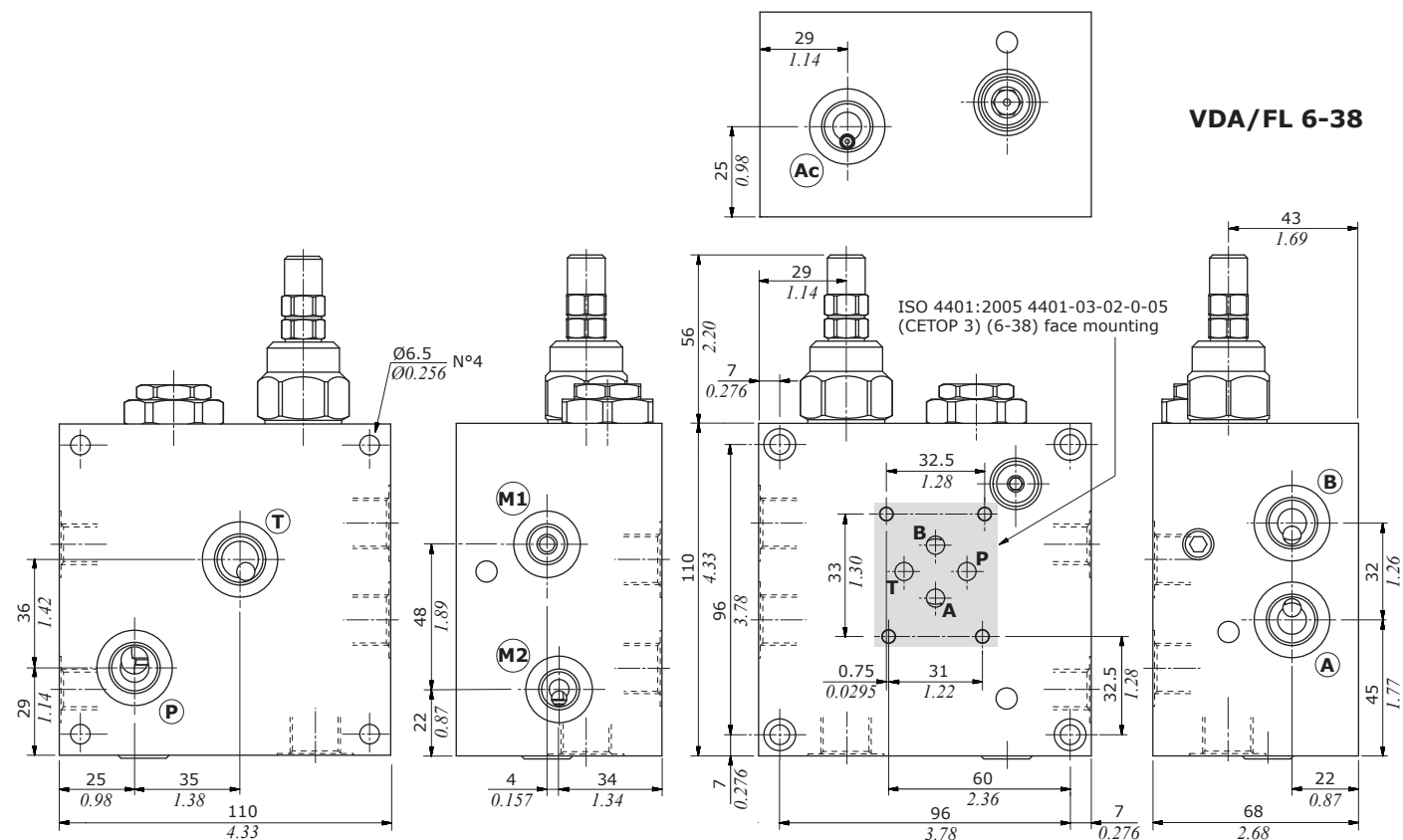

VDA/FL 6-38

Valve type	A-B	P-T	M1	M2	Ac
VDA/FL 6-38	G3/8	G3/8	G1/4	G1/4	G3/8
VDA/FL 10-12	G1/2	G1/2	G1/4	G1/4	G1/2

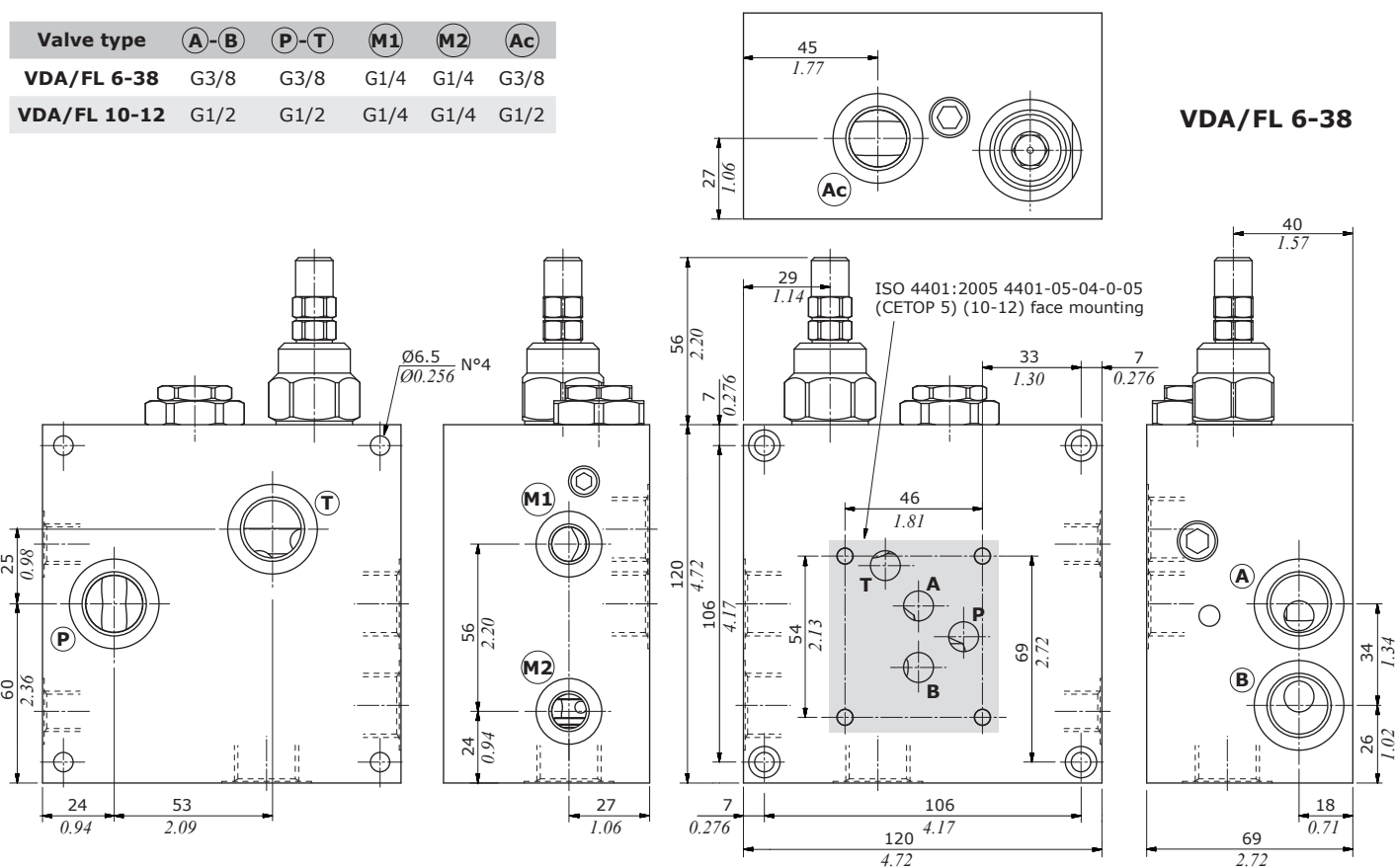

VDA/FL 6-38

Ordering codes and description composition

Port size
VDA/FL 6-38/TR.S.VRR
1

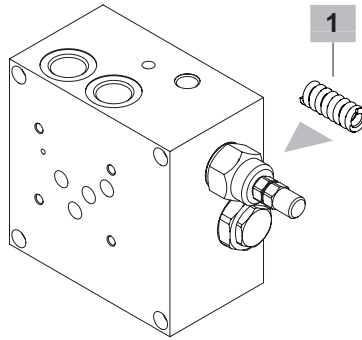

VDA/FL complete valves

Standard setting 200 bar (2900 psi) at 5 l/min (1.32 US gpm)

Standard differential pressure 15%

TYPE	CODE	DESCRIPTION
------	------	-------------

Configuration with G3/8 standard thread

VDA/FL 6-38/TR.S.VRR	1214021101	Aluminium body, range 100-250 bar (1450-3600 psi)
-----------------------------	------------	---

VDA/FL 6-38/TR.S.VRR/ac	1214022100	Steel body, as previous one
--------------------------------	------------	-----------------------------

Configuration with G1/2 standard thread

VDA/FL 10-12/TR.S.VRR	1214031101	Aluminium body, range 100-250 bar (1450-3600 psi)
------------------------------	------------	---

VDA/FL 10-12/TR.S.VRR/ac	1214032100	Steel body, as previous one
---------------------------------	------------	-----------------------------

For other steel body configurations, SAE thread and configurations with FPM (Viton) seals, contact our Sales Dpt.

1 Pressure setting springs

TYPE	CODE	DESCRIPTION
TV	3ML1164000	Setting range 5-110 bar (72.5-1600 psi)
TR	3ML1164001	Setting range 100-250 bar (1450-3600 psi)

Rating diagrams

VDA/FL 6-38 P→T pressure drop vs. flow

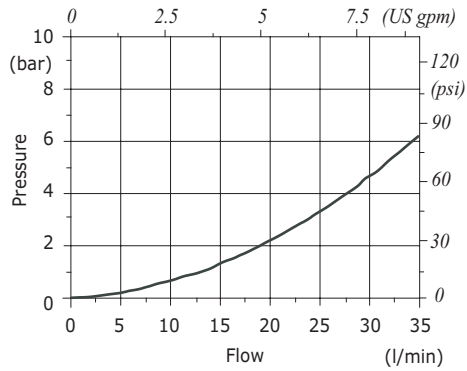

VDA/FL 6-38 P→P cetop pressure drop vs. flow

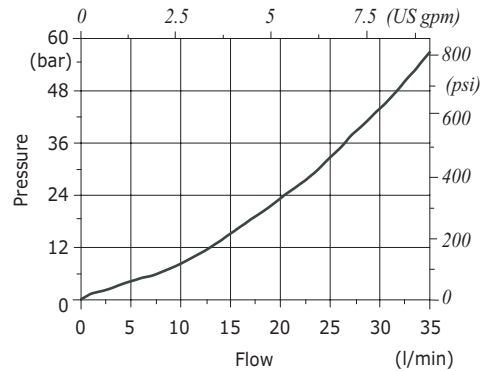

VDA/FL 10-12 P→T pressure drop vs. flow

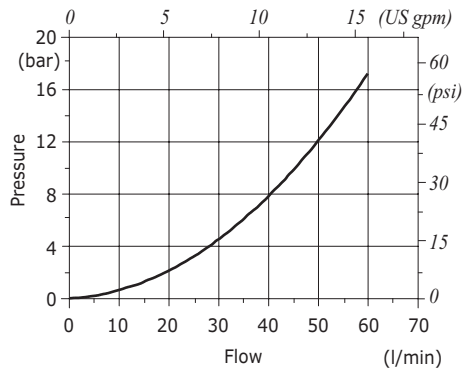

VDA/FL 10-12 P→P cetop pressure drop vs. flow

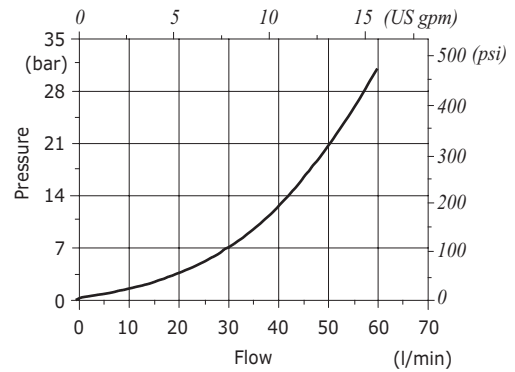

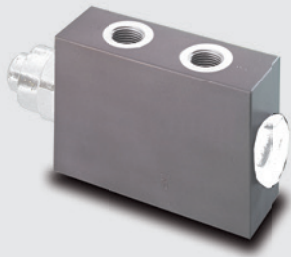

Type VRCL/KD regenerative valves

- Regenerative

Technical specifications and diagrams are measured with mineral oil of 46 cSt viscosity at 40°C (104°F) temperature.

	VRCL/KD 38	VRCL/KD 12	VRCL/KD 34	VRCL/KD 100
Nominal flow	30 l/min (7.9 US gpm)	50 l/min (13.2 US gpm)	90 l/min (23.8 US gpm)	150 l/min (39.6 US gpm)
Max. pressure	350 bar (5100 psi)			
Fluid	mineral based oil			
Viscosity	from 10 to 200 cSt			
Max. level of contamination	18/16/13 ISO4406			
Fluid temperature	with NBR seals from -20°C (-4°F) to 80°C (176°F)			
Environmental temp. for working conditions	from -40°C (-40°F) to 100°C (212°F)			
Weight	steel 3.65 kg (8.05 lb)	3.55 kg (7.83 lb)	5.50 kg (12.12 lb)	10.12 kg (22.31 lb)

NOTE - For different conditions, please contact Walvoil Sales Dpt.

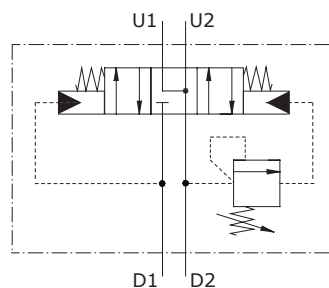

Dimensions

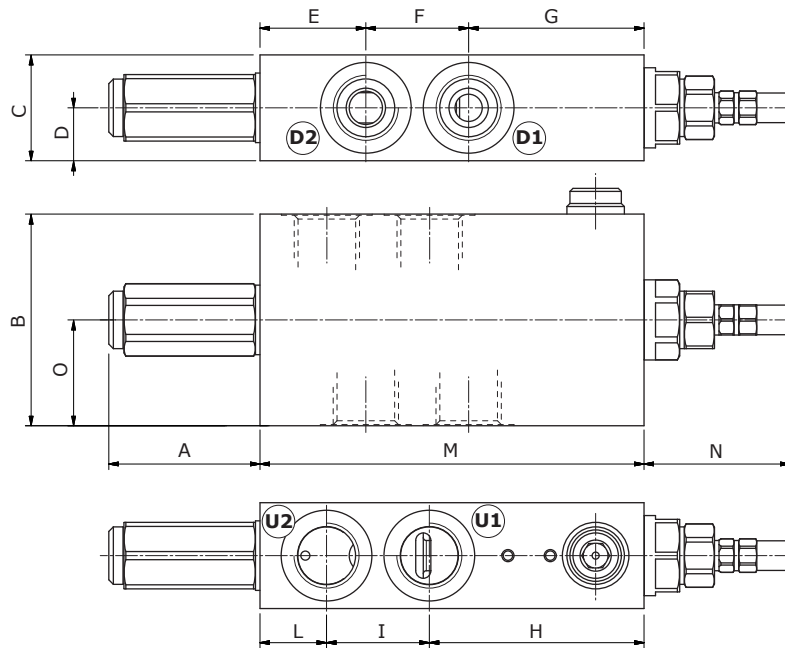

Valve type	All ports
VRCL/KD 38	G3/8
VRCL/KD 12	G1/2

Dimensions are in mm-in

Valve Type	A	B	C	D	E	F	G	H	I	L	M	N	O
VRCL/KD 38	50-1.97	70-2.75	35-1.38	17.5-0.69	35-1.38	34-1.34	58-2.28	71-2.79	34-1.34	22-0.87	127-5	48.5-1.91	35-1.38
VRCL/KD 12	50-1.97	70-2.75	35-1.38	17.5-0.69	35-1.38	34-1.34	58-2.28	71-2.79	34-1.34	22-0.87	127-5	48.5-1.91	35-1.38

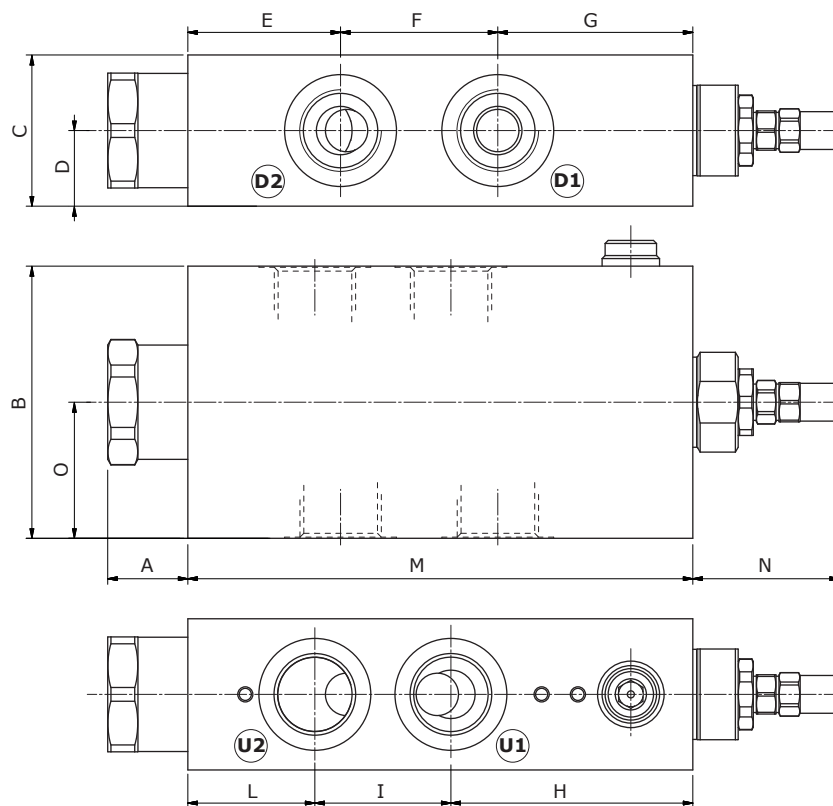

Valve type	All ports
VRCL/KD 34	G3/4
VRCL/KD 100	G1"

Dimensions are in mm-in

Valve Type	A	B	C	D	E	F	G	H	I	L	M	N	O
VRCL/KD 34	27-1.06	90-3.54	50-1.97	25-0.98	50.5-1.99	52-2.05	64.5-2.54	80-3.15	45-1.77	42-1.65	167-6.57	48.5-1.91	45-1.77
VRCL/KD 100	26-1.02	100-3.94	60-2.36	30-1.18	77-3.03	68-2.68	90-3.54	111.5-4.39	57-2.24	66.5-2.62	235-9.25	43-1.69	50-1.97

Ordering codes and description composition

Port size
VRCL/KD 38/TS.S
1

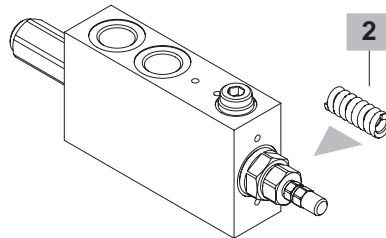

VRCL/KD complete valves

Steel body, standard setting 100 bar (1450 psi) at 10 l/min (2.64 US gpm)

TYPE	CODE	DESCRIPTION
VRCL/KD 38/TS.S/ac	1245023102	G3/8 port thread, setting range 50-220 bar (725-3200 psi)
VRCL/KD 12/TS.S/ac	1245033101	G1/2 port thread, setting range 50-220 bar (725-3200 psi)
VRCL/KD 34/TS.S/ac	1245043100	G3/4 port thread, setting range 50-220 bar (725-3200 psi)
VRCL/KD 100/TS.S/ac	1245053100	G1" port thread, setting range 50-220 bar (725-3200 psi)

For other configurations, SAE threads and configurations with FPM (Viton) seals, please contact our Sales Dpt.

1 Pressure setting springs

TYPE	CODE	DESCRIPTION
For VRCL/KD 38 and VRCL/KD 12 valves		
TB	3ML1081400	Setting range 5-80 bar (72.5-725 psi)
TS	3ML1081401	Setting range 50-220 bar (725-3200 psi)
TR	3ML1081402	Setting range 180-350 bar (2600-5100 psi)
For VRCL/KD 34 and VRCL/KD 100 valves		
TV	3ML1092500	Setting range 5-50 bar (72.5-1150 psi)
TS	3ML1092501	Setting range 20-220 bar (290-3200 psi)
TR	3ML1092502	Setting range 180-350 bar (2600-5100 psi)

Rating diagrams

VRCL/KD 38 pressure drop vs. flow

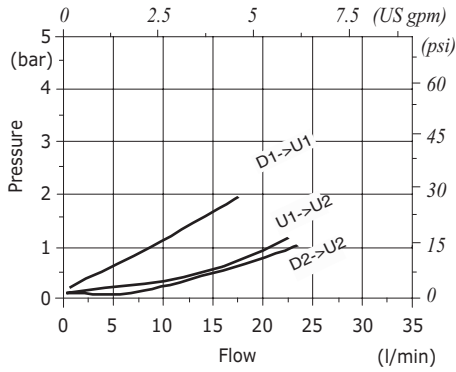

VRCL/KD 12 pressure drop vs. flow

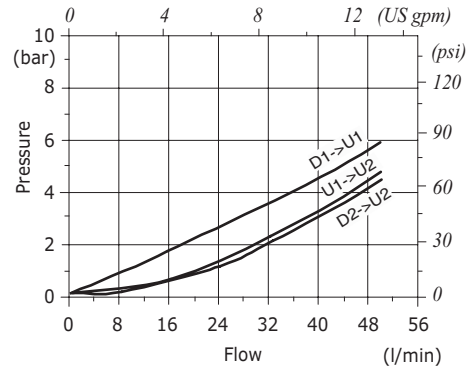

VRCL/KD 34 pressure drop vs. flow

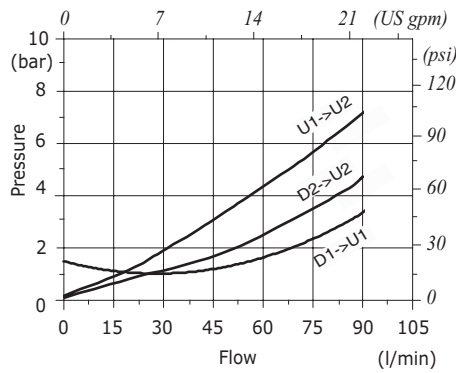

VRCL/KD 100 pressure drop vs. flow

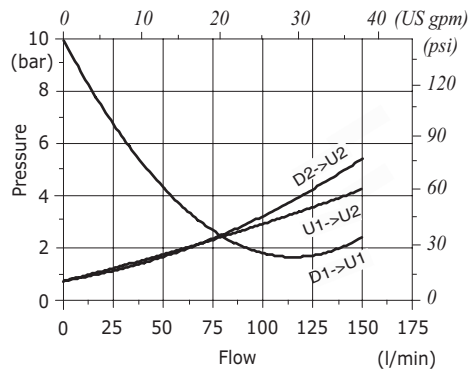



Type VEP two pump "high-low" unloading valves

- Single acting
- "High-low pressure"

Technical specifications and diagrams are measured with mineral oil of 46 cSt viscosity at 40°C (104°F) temperature.

Line	VEP 38	VEP 12	VEP 34	VEP 100	VEP 114	
Nominal flow	Ap (high pressure inlet port)	10 l/min (2.6 US gpm)	20 l/min (5.3 US gpm)	30 l/min (7.9 US gpm)	50 l/min (13.2 US gpm)	80 l/min (21.1 US gpm)
	Bp (low pressure inlet port)	25 l/min (6.6 US gpm)	45 l/min (11.9 US gpm)	80 l/min (21.1 US gpm)	150 l/min (39.6 US gpm)	200 l/min (52.8 US gpm)
	U (work port)	30 l/min (7.9 US gpm)	55 l/min (14.5 US gpm)	100 l/min (26.4 US gpm)	180 l/min (47.6 US gpm)	250 l/min (66 US gpm)
Max. pressure	Aluminium body = 210 bar (3050 psi) Steel body = 350 bar (5100 psi)					
Fluid	mineral based oil					
Viscosity	from 10 to 200 cSt					
Max. level of contamination	18/16/13 ISO4406					
Fluid temperature	with NBR seals from -20°C (-4°F) to 80°C (176°F)					
Environmental temp. for working conditions	from -40°C (-40°F) to 100°C (212°F)					
Weight	<i>aluminium</i>	1.20 kg (2.64 lb)	2.05 kg (4.52 lb)	3.70 kg (8.16 lb)	5.92 kg (13.05 lb)	11.67 kg (25.72 lb)
	<i>steel</i>	2.63 kg (5.80 lb)	4.50 kg (9.92 lb)	9.37 kg (20.66 lb)	14.48 kg (31.92 lb)	19.50 kg (42.99 lb)

NOTE - For different conditions, please contact Walvoil Sales Dpt.

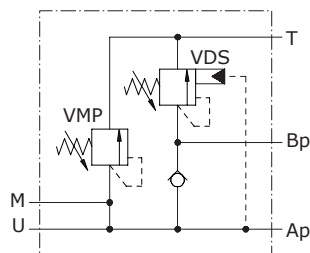

Dimensions

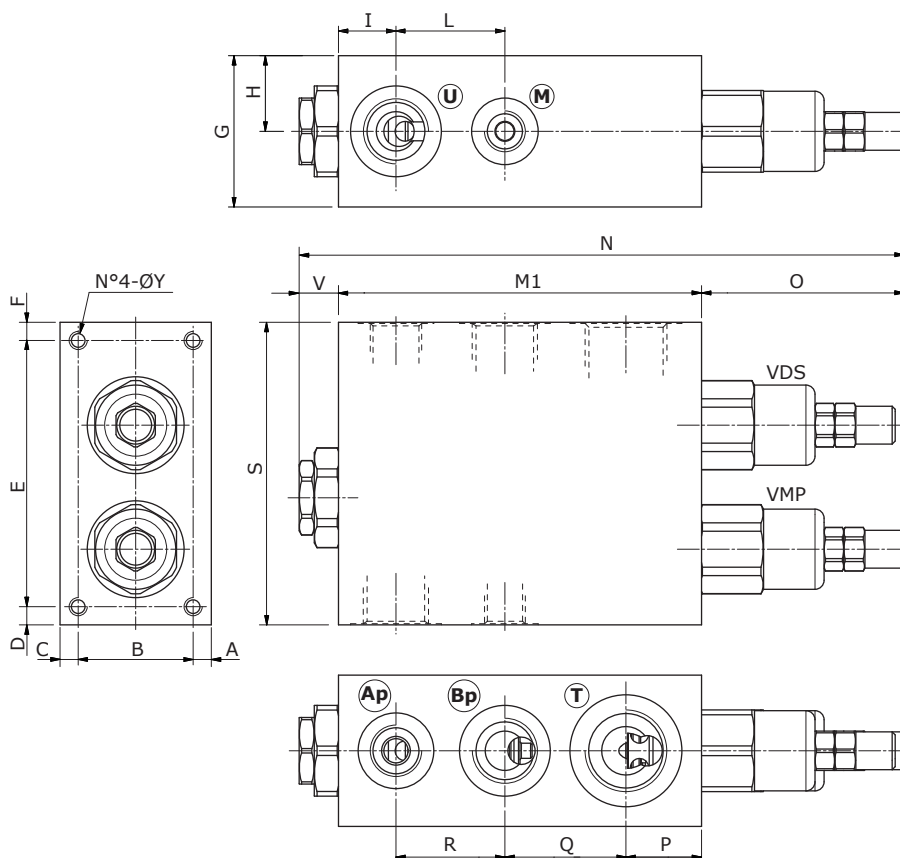

Valve type	U	M	T	Ap	Bp	Valve type	U	M	T	Ap	Bp
VEP 38	G3/8	G1/4	G1/2	G1/4	G3/8	VEP 38/SAE	SAE8	SAE6	SAE10	SAE6	SAE8
VEP 12	G1/2	G1/4	G3/4	G3/8	G1/2	VEP 12/SAE	SAE10	SAE6	SAE12	SAE8	SAE10
VEP 34	G3/4	G1/4	G1"	G1/2	G3/4	VEP 34/SAE	SAE12	SAE6	SAE16	SAE10	SAE12
VEP 100	G1"	G1/4	G1"1/4	G3/4	G1"	VEP 100/SAE	SAE16	SAE6	SAE20	SAE12	SAE16
VEP 114	G1"1/4	G1/4	G1"1/2	G3/4	G1"1/4	VEP 114/SAE	SAE20	SAE6	SAE24	SAE12	SAE20

Dimensions are in mm-in

Valve type	A	B	C	D	E	F	G	H	I	L	M1	N	O	ØY	P	Q	R	S	V
VEP 38	6	28	6	6	78	6	40	20	17	28	98	168.5	60	M6	20	33	29	90	10.5
VEP 38/SAE	0.24	1.10	0.24	0.24	3.07	0.24	1.57	0.79	0.67	1.10	3.85	6.63	2.36	M6	0.79	1.30	1.14	3.54	0.41
VEP 12	6	38	6	6	88	6	50	25	19	36	120	200	67	M6	25	40	36	100	13
VEP 12/SAE	0.24	1.50	0.24	0.24	3.46	0.24	1.97	0.98	0.75	1.42	4.72	7.87	2.64	M6	0.98	1.57	1.42	3.94	0.51
VEP 34	8	44	8	8	114	8	60	30	30	40	150	243	76.5	M8	28	52	40	130	16.5
VEP 34/SAE	0.31	1.73	0.31	0.31	4.49	0.31	2.36	1.18	1.18	1.57	5.90	9.57	3.01	M8	1.10	2.05	1.57	5.11	0.65
VEP 100	10	50	10	10	130	10	70	35	30	70	180	285	88.5	M6	32	60	58	150	16.5
VEP 100/SAE	0.39	1.97	0.39	0.39	5.11	0.39	2.75	1.38	1.18	2.75	7.09	11.22	3.48	M6	1.26	2.36	2.28	5.90	0.65
VEP 114	10	60	10	10	160	10	80	40	40	80	200	304	88.5	M8	35	70	60	180	15.5
VEP 114/SAE	0.39	2.36	0.39	0.39	6.3	0.39	3.15	1.57	1.57	3.15	7.87	11.97	3.48	M8	1.38	2.75	2.34	7.09	0.61

Logic valves

Two pump "hi-low" unloading-valves

Ordering codes and description composition

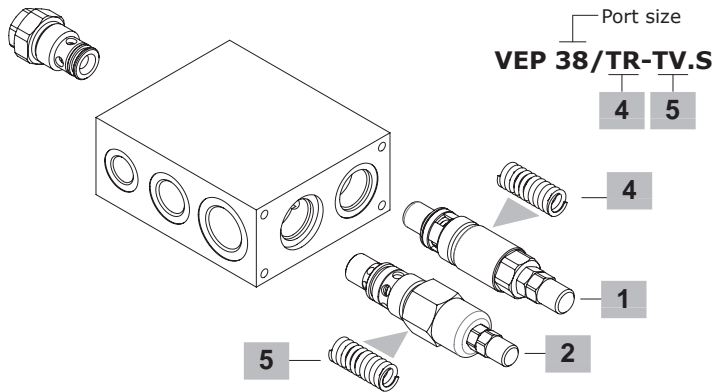

VEP complete valves

Single type valve configuration

High pressure (Ap): range 180-350 bar (2600-5075 psi) and standard setting 280 bar (4060 psi) at 5 l/min (1.32 US gpm); Low Pressure (Bp): see below

TYPE CODE DESCRIPTION

Configuration with G3/8 standard thread

VEP 38/TR-TV.S 1220021101 Aluminium body
Bp: range 20-80 bar (290-1160 psi) - Standard setting 60 bar (870 psi) at 5l/min (1.32 US gpm)

VEP 38/TR-TV.S/ac 1220022102 Steel body, as previous one

Configuration with G1/2 standard thread

VEP 12/TR-TV.S 1220031101 Aluminium body
Bp: range 5-80 bar (72.5-1160 psi) - Standard setting 40 bar (580 psi) at 5l/min (1.32 US gpm)

VEP 12/TR-TV.S/ac 1220032100 Steel body, as previous one

Configuration with G3/4 standard thread

VEP 34/TR-TV.S 1220041101 Aluminium body
Bp: range 10-80 bar (145-1160 psi) - Standard setting 50 bar (725 psi) at 5 l/min (1.32 US gpm)

VEP 34/TR-TV.S/ac 1220042100 Steel body, as previous one

Configuration with G1" standard thread

VEP 100/TR-TV.S 1220051101 Aluminium body
Bp: range 20-80 bar (290-1160 psi) - Standard setting 60 bar (870 psi) at 5l/min (1.32 US gpm)

VEP 100/TR-TV.S/ac 1220052101 Steel body, as previous one

Configuration with G1"1/4 standard thread

VEP 114/TR-TV.S 1220061101 Aluminium body
Bp: range 20-80 bar (290-1160 psi) - Standard setting 60 bar (870 psi) at 5l/min (1.32 US gpm)

VEP 114/TR-TV.S/ac 1220062100 Steel body, as previous one

Configuration with SAE8 standard thread

VEP 38/TR-TV.S/SAE 1220021200 Aluminium body
Bp: range 20-80 bar (290-1160 psi) - Standard setting 60 bar (870 psi) at 5l/min (1.32 US gpm)

Configuration with SAE10 standard thread

VEP 12/TR-TV.S/SAE 1220031101 Aluminium body
Bp: range 5-80 bar (72.5-1160 psi) - Standard setting 40 bar (580 psi) at 5l/min (1.32 US gpm)

Configuration with SAE12 standard thread

VEP 34/TR-TV.S/SAE 1220041200 Aluminium body
Bp: range 10-80 bar (145-1160 psi) - Standard setting 50 bar (725 psi) at 5 l/min (1.32 US gpm)

Configuration with SAE16 standard thread

VEP 100/TR-TV.S/SAE 1220051200 Aluminium body
Bp: range 20-80 bar (290-1160 psi) - Standard setting 60 bar (870 psi) at 5l/min (1.32 US gpm)

VEP complete valves (continue)

TYPE CODE DESCRIPTION

Configuration with SAE20 standard thread

VEP 114/TR-TV.S/SAE 1220061200 Aluminium body
Bp: range 20-80 bar (290-1160 psi) - Standard setting 60 bar (870 psi) at 5l/min (1.32 US gpm)

For other steel body configurations, other port sizes and configurations with FPM (Viton) seals, contact our Sales Dpt.

1 Direct acting pressure relief valve

Standard setting 160 bar at 5 l/min (2320 psi at 1.32 US gpm)

TYPE CODE DESCRIPTION

For G3/8 and SAE8 ports configuration

VMP 5/TR.S 1100520401 Setting range 50-220 bar (725-3200 psi) (Ap)

For G1/2, G3/4, SAE10 and SAE12 ports configuration

VMP 10/TR.S 1100530401 Setting range 50-220 bar (725-3200 psi) (Ap)

For G1", G1"1/4, SAE16 and SAE20 ports configuration

VMP 20/TR.S 1100540403 Setting range 50-220 bar (725-3200 psi) (Ap)

2 Sequence valve

Setting range 20-80 bar (290-1150 psi) (Lp)

Standard setting 160 bar at 5 l/min (2320 psi at 1.32 US gpm)

TYPE CODE DESCRIPTION

VDS/VEP 38/TV.S 1205020400 For G3/8 - SAE8 port configuration

VDS/VEP 12/TV.S 1205030400 For G1/2 - SAE10 port configuration

VDS/VEP 34/TV.S 1205040405 For G3/4 - SAE12 port configuration

VDS/VEP 100/TV.S 1205050400 For G1" - SAE16 port configuration

VDS/VEP 114/TV.S 1205060400 For G1"1/4 - SAE20 port configuration

3 Check valve

Opening pressure 0.5 bar (7.25 psi)

TYPE CODE DESCRIPTION

VUI 38/Pa0,5 1300020400 For G3/8 - SAE8 port configuration

VUI 12/Pa0,5 pass.magg 1300030401 For G1/2 - SAE10 port configuration

VUI 34/Pa0,5 pass.magg 1300040401 For G3/4, G1", SAE12, SAE16 port config.

VUI 100/Pa0,5 pass.magg 1300050401 For G1"1/4, SAE20 port configuration

4 Pressure setting springs

TYPE CODE DESCRIPTION

For VMP 5 valve on VEP 38 complete valve (Ap)

TS 3MOL315330 Setting range 50-220 bar (725-3200 psi)

TR 3ML1143600 Setting range 180-350 bar (2600-5100 psi)

For VMP 10 valve on VEP 12 and VEP 34 complete valves (Ap)

TS 3MOL317420 Setting range 50-220 bar (725-3200 psi)

TR 3MOL317440 Setting range 180-350 bar (2600-5100 psi)

For VMP 20 valve on VEP 100 and 114 complete valves (Ap)

TS 3ML1204200 Setting range 50-220 bar (725-3200 psi)

TR 3ML1214500 Setting range 180-350 bar (2600-5100 psi)

5 Pressure setting springs

TYPE CODE DESCRIPTION

For VDS/VEP 38 valve on VEP 38 complete valve (Bp)

TB 3MOL314311 Setting range 5-40 bar (72.5-580 psi)

TV 3MOL314330 Setting range 20-80 bar (290-1150 psi)

For VDS/VEP 12 valve on VEP 12 complete valve (Bp)

TV 3MOL317420 Setting range 5-80 bar (72.5-1150 psi)

For VDS/VEP 34 valve on VEP 34 complete valve (Bp)

TB 3ML1174500 Setting range 10-50 bar (145-725 psi)

TV 3ML1204200 Setting range 10-80 bar (145-1150 psi)

For VDS/VEP 100 valve on VEP 100 complete valve (Bp)

TB 3MOL314311 Setting range 5-40 bar (72.5-580 psi)

TV 3MOL314330 Setting range 20-80 bar (290-1150 psi)

For VDS/VEP 114 valve on VEP 114 complete valve (Bp)

TB 3MOL314311 Setting range 5-40 bar (72.5-580 psi)

TV 3MOL314330 Setting range 20-80 bar (290-1150 psi)

Rating diagrams

VEP 38 pressure drop vs. flow from Bp→T and Bp→U

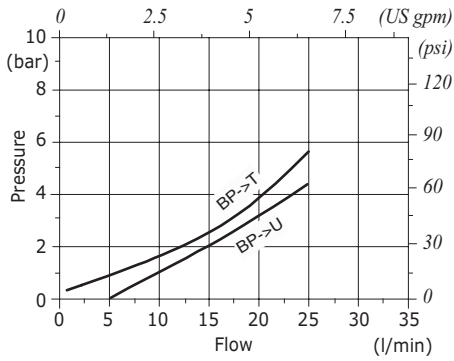

VEP 12 pressure drop vs. flow from BP→T and BP→U

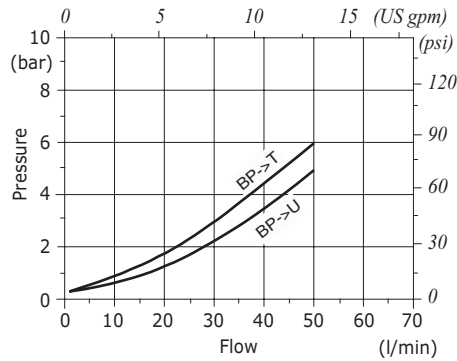

VEP 34 pressure drop vs. flow from Bp→T and Bp→U

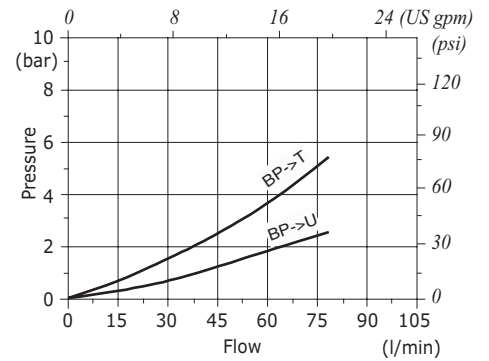

VEP 100 pressure drop vs. flow from Bp→T and Bp→U

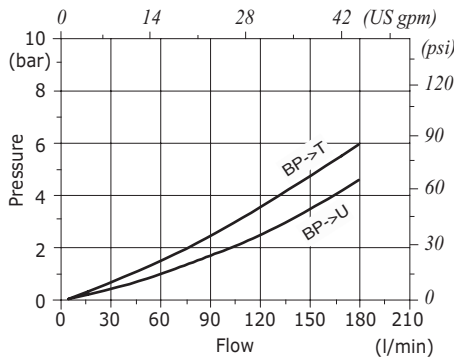

VEP 114 pressure drop vs. flow from Bp→T and Bp→U

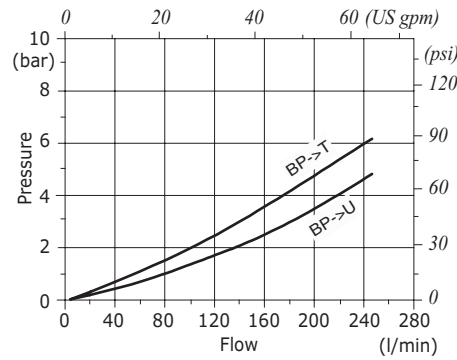

VEP 38: VMP setting example at 5 l/min (1.32 US gpm)

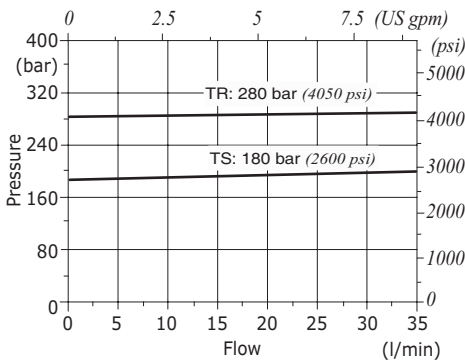

VEP 12: VMP setting example at 5 l/min (1.32 US gpm)

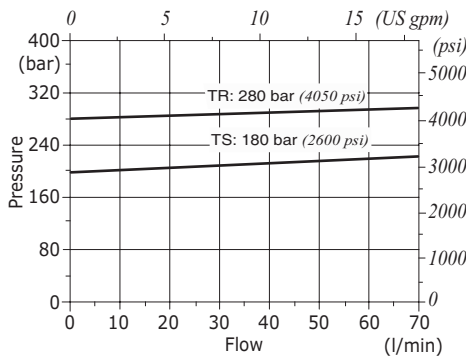

VEP 34: VMP setting example at 5 l/min (1.32 US gpm)

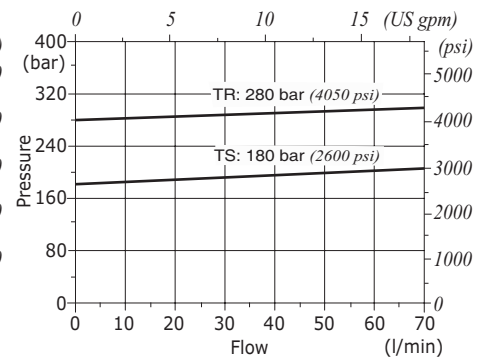

VEP 100: VMP setting example at 5 l/min (1.32 US gpm)

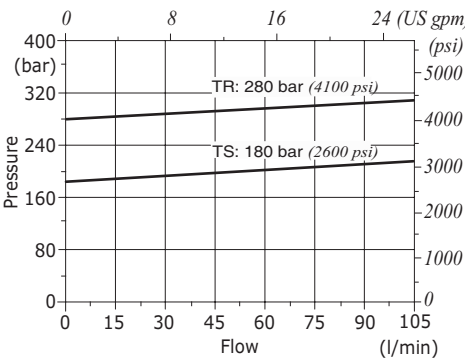

VEP 114: VMP setting example at 5 l/min (1.32 US gpm)

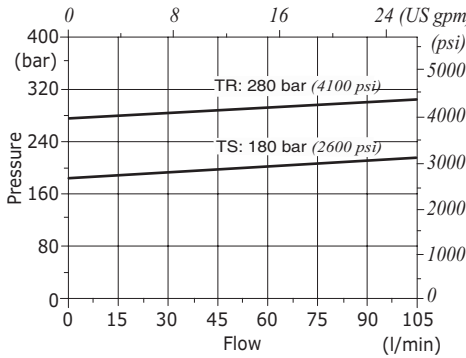

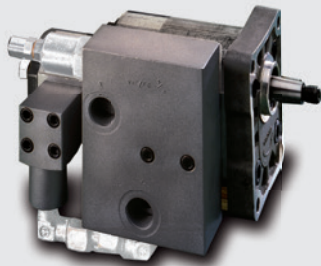

Type VEP/FC two pump "high-low" unloading valves

- Single acting
- Flanged solution

Technical specifications and diagrams are measured with mineral oil of 46 cSt viscosity at 40°C (104°F) temperature.

Line	VEP/FC 38	VEP/FC 12	VEP/FC 34	VEP/FC 100	
Nominal flow	Ap (high pressure inlet port)	10 l/min (2.6 US gpm)	20 l/min (5.3 US gpm)	30 l/min (7.9 US gpm)	50 l/min (13.2 US gpm)
	Bp (low pressure inlet port)	25 l/min (6.6 US gpm)	45 l/min (11.9 US gpm)	80 l/min (21.1 US gpm)	150 l/min (39.6 US gpm)
	U (work port)	30 l/min (7.9 US gpm)	55 l/min (14.5 US gpm)	100 l/min (26.4 US gpm)	180 l/min (47.6 US gpm)
Max. pressure	Aluminium body = 210 bar (3050 psi) Steel body = 350 bar (5100 psi)				
Fluid	mineral based oil				
Viscosity	from 10 to 200 cSt				
Max. level of contamination	18/16/13 ISO4406				
Fluid temperature	with NBR seals from -20°C (-4°F) to 80°C (176°F) with FPM seals from -20°C (-4°F) to 100°C (212°F)				
Environmental temp. for working conditions	from -40°C (-40°F) to 100°C (212°F)				
Weight	aluminium	1.36 kg (3.05 lb)	2.50 kg (5.51 lb)	3.50 kg (7.72 lb)	6.21 kg (13.69 lb)
	steel	2.48 kg (5.47 lb)	4.22 kg (9.30 lb)	7.91 kg (17.44 lb)	-

NOTE - For different conditions, please contact Walvoil Sales Dpt.

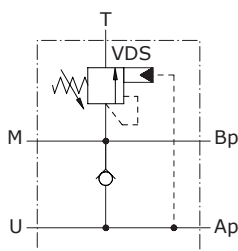

Valve type	(M)	(T-U)
VEP/FC 38 Gr 1+1	G1/4	G3/8
VEP/FC 12 Gr 2+1	G1/4	G1/2
VEP/FC 12 Gr 2+2	G1/4	G1/2
VEP/FC 34 Gr 3+1	G1/4	G3/4
VEP/FC 34 Gr 3+1	G1/4	G3/4
VEP/FC 34 Gr 3+2	G1/4	G3/4
VEP/FC 50 Gr 3+3	G1/4	G1"
VEP/FC 100 Gr 3,5+3	G1/4	G1"

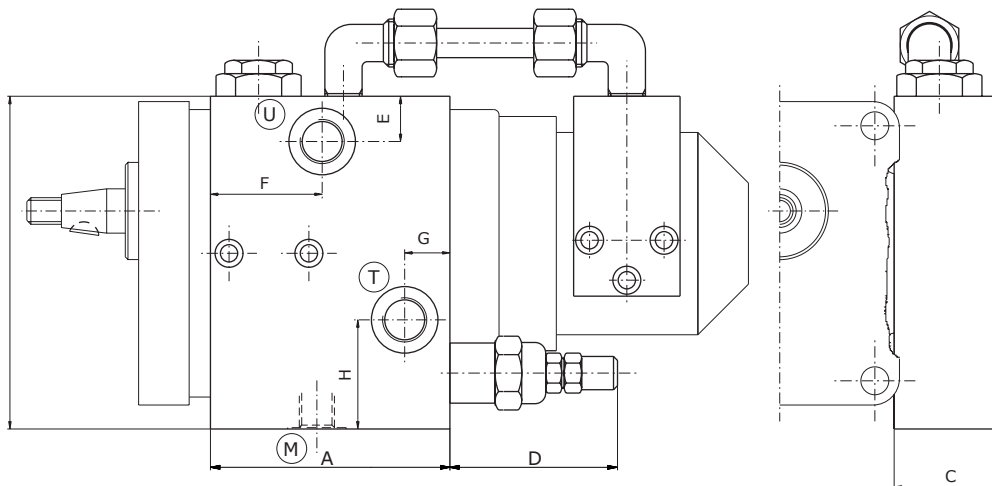

Dimensions are in mm-in

Valve type	A	B	C	D	E	F	G	H	Ap	Bp
VEP/FC 38 Gr 1+1	80 3.15	90 3.54	40 1.57	60 2.36	15 0.59	46 1.81	18 0.7	30 1.18	10 0.39	25 0.98
VEP/FC 12 Gr 2+1	90 3.54	125 4.92	40 1.57	65 2.56	17 0.67	43 1.69	17 0.67	41 1.61	15 0.59	45 1.77
VEP/FC 12 Gr 2+2	90 3.54	125 4.92	40 1.57	65 2.56	17 0.67	43 1.69	17 0.67	41 1.61	25 0.98	45 1.77
VEP/FC 34 Gr 3+1	120 4.72	130 5.11	60 2.36	72 2.83	30 1.18	64 2.52	22 0.86	51 2	20 0.79	80 3.15
VEP/FC 34 Gr 3+1	120 4.72	130 5.11	60 2.36	72 2.83	30 1.18	64 2.52	22 0.86	51 2	35 1.38	80 3.15
VEP/FC 34 Gr 3+2	120 4.72	130 5.11	60 2.36	72 2.83	30 1.18	64 2.52	22 0.86	51 2	45 1.77	80 3.15
VEP/FC 50 Gr 3+3	140 5.51	160 6.3	75 2.95	90 3.54	31 1.22	84 3.3	32 1.26	66 2.6	60 2.36	120 4.72
VEP/FC 100 Gr 3,5+3	140 5.51	160 6.3	75 2.95	90 3.54	31 1.22	84 3.3	32 1.26	66 2.6	80 3.15	150 5.9

Valve type	(U)	(T)	(M)	(Ap - Bp)
VEP/FC 38 Gr 1+1 PLP	G3/8	G3/8	G1/4	Flanged ports

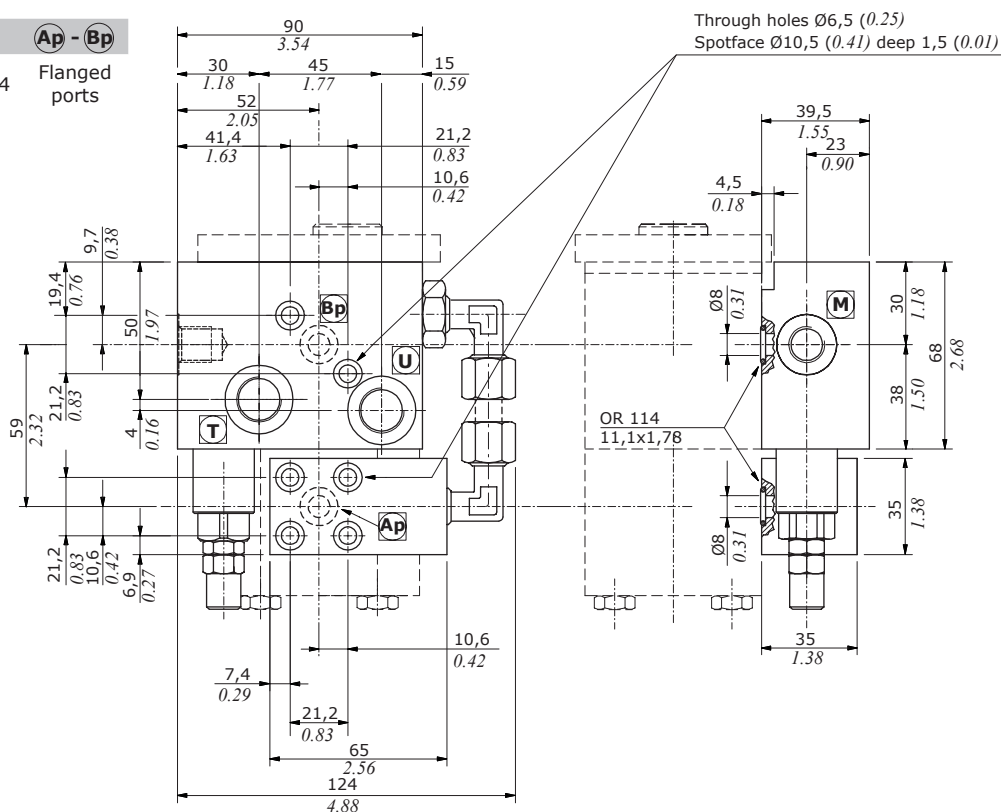

Logic valves

Two pump "hi-low" unloading-valves

VEP/FC

Ordering codes and description composition

Port size
VEP/FC 38/Gr1+1/TV.S

3

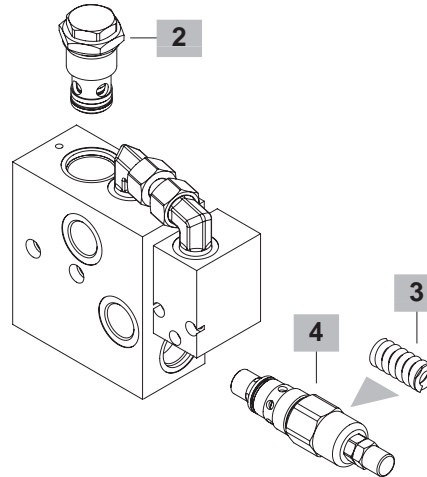

VEP/FC complete valves

Single type valve configuration; standard setting is referred to 5 l/min (1.32 US gpm)

Configuration with G3/8 standard thread

TYPE: **VEP/FC 38/Gr1+1/TV.S** CODE: 1222021100
DESCRIPTION: Aluminium body, range 20-80 bar (290-1160 psi), standard setting 60 bar (870 psi)

TYPE: **VEP/FC 38/Gr1+1/TV.S/ac** CODE: 1222022100
DESCRIPTION: Steel body, as previous one

TYPE: **VEP/FC 38/Gr1+1/PLP/TV.S** CODE: 1222021107
DESCRIPTION: Aluminium body, range 20-80 bar (290-1160 psi), standard setting 60 bar (870 psi), with "PLP" special flange

Configuration with G1/2 standard thread

TYPE: **VEP/FC 12/Gr2+1/TV.S** CODE: 1222031100
DESCRIPTION: Aluminium body, range 5-80 bar (72.5-1160 psi), standard setting 40 bar (580 psi)

TYPE: **VEP/FC 12/Gr2+1/TV.S/ac** CODE: 1222032105
DESCRIPTION: Steel body, as previous one

TYPE: **VEP/FC 12/Gr2+2/TV.S** CODE: 1222031101
DESCRIPTION: Aluminium body, range 5-80 bar (72.5-1160 psi), standard setting 40 bar (580 psi)

TYPE: **VEP/FC 12/Gr2+2/TV.S/ac** CODE: 1222032100
DESCRIPTION: Steel body, as previous one

Configuration with G3/4 standard thread

TYPE: **VEP/FC 34/Gr3+1/TV.S** CODE: 1222041100
DESCRIPTION: Aluminium body, range 10-50 bar (145-725 psi), standard setting 50 bar (725 psi)

TYPE: **VEP/FC 34/Gr3+2/TV.S** CODE: 1222041101
DESCRIPTION: Aluminium body, range 10-80 bar (145-1160 psi), standard setting 50 bar (725 psi)

TYPE: **VEP/FC 34/Gr3+2/TV.S/ac** CODE: 1222042101
DESCRIPTION: Steel body, as previous one

TYPE: **VEP/FC 34/Gr3+3/TV.S** CODE: 1222041102
DESCRIPTION: Aluminium body, range 10-80 bar (145-1160 psi), standard setting 50 bar (725 psi)

Configuration with G 1" standard thread

TYPE: **VEP/FC 100/Gr3,5+3/TV.S** CODE: 1222051100
DESCRIPTION: Aluminium body, range 20-80 bar (290-1160 psi), standard setting 60 bar (870 psi)

For not listed steel body configurations, different flanging, SAE thread, or configurations with FPM (Viton) seals, please contact our Sales Dpt.

1 Sequence valve

Setting range 20-80 bar (290-1150 psi) (Lp)

Standard setting 160 bar at 5 l/min (2320 psi at 1.32 US gpm)

TYPE	CODE	DESCRIPTION
VDS/VEP 38/TV.S	1205020400	For G3/8 port configuration
VDS/VEP 12/TV.S	1205030400	For G1/2 port configuration
VDS/VEP 34/TV.S	1205040405	For G3/4 port configuration
VDS/VEP 100/TV.S	1205050400	For G1" port configuration

2 Check valve

Opening pressure 0.5 bar (7.25 psi)

TYPE	CODE	DESCRIPTION
VUI 38/Pa0,5	1300020400	For G3/8 port configuration
VUI 12/Pa0,5 pass.magg	1300030401	For G1/2 port configuration
VUI 34/Pa0,5 pass.magg	1300040401	For G3/4 and G1" port configuration

3 Pressure setting springs

TYPE	CODE	DESCRIPTION
For VDS/VEP 38 valve on VEP/FC 38 complete valve		
TB	3MOL314311	Setting range 5-40 bar (72.5-580 psi)
TV	3MOL314330	Setting range 20-80 bar (290-1150 psi)
For VDS/VEP 12 valve on VEP/FC 12 complete valve		
TV	3MOL317420	Setting range 5-80 bar (72.5-1150 psi)
For VDS/VEP 34 valve on VEP/FC 34 complete valve		
TB	3ML1174500	Setting range 10-50 bar (145-725 psi)
TV	3ML1204200	Setting range 10-80 bar (145-1150 psi)
For VDS/VEP 100 valve on VEP/FC 100 complete valve		
TB	3MOL314311	Setting range 5-40 bar (72.5-580 psi)
TV	3MOL314330	Setting range 20-80 bar (290-1150 psi)

Rating diagrams

VEP/FC 38-12 pressure drop vs. flow from Bp→T and Bp→U

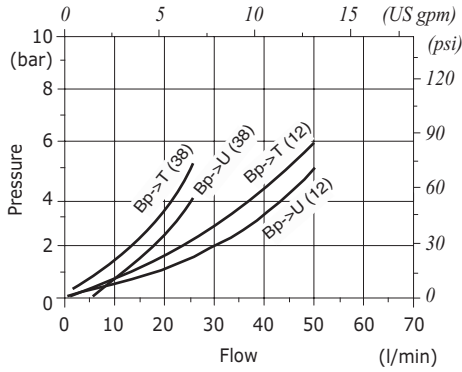

VEP/FC 34-100 pressure drop vs. flow from Bp→T and Bp→U

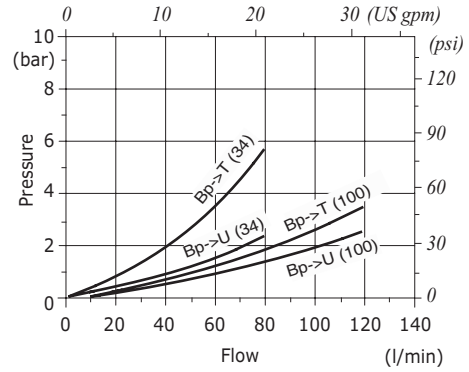

VEP/FC 38 PLP pressure drop vs. flow from Bp→T and Bp→U

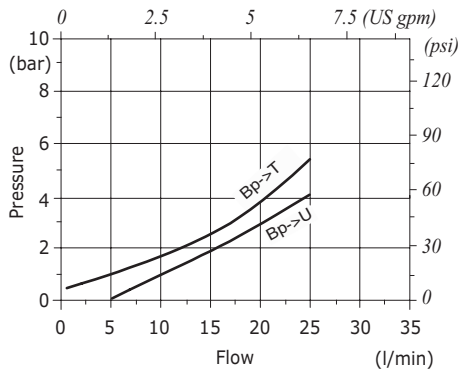

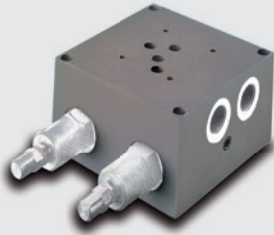

Type VEP/FL two pump "high-low" unloading valves

- Cetop 3 (6-38) - 5 (10-12) - 7 (16-34 and 16-100) flanging
- Flange assembling according to ISO 4401:2005 (CETOP)

Technical specifications and diagrams are measured with mineral oil of 46 cSt viscosity at 40°C (104°F) temperature.

Line	VEP/FL 6-38	VEP/FL 10-12	VEP/FL 16-34	VEP/FL 16-100	
Nominal flow	Ap (high pressure inlet port)	10 l/min (2.6 US gpm)	20 l/min (5.3 US gpm)	30 l/min (7.9 US gpm)	30 l/min (7.9 US gpm)
	Bp (low pressure inlet port)	25 l/min (6.6 US gpm)	45 l/min (11.9 US gpm)	80 l/min (21.1 US gpm)	80 l/min (21.1 US gpm)
	U (work port)	30 l/min (7.9 US gpm)	55 l/min (14.5 US gpm)	100 l/min (26.4 US gpm)	100 l/min (26.4 US gpm)
Max. pressure	Aluminium body = 210 bar (3050 psi) Steel body = 350 bar (5100 psi)				
Fluid	mineral based oil				
Viscosity	from 10 to 200 cSt				
Max. level of contamination	18/16/13 ISO4406				
Fluid temperature	with NBR seals from -20°C (-4°F) to 80°C (176°F)				
Environmental temp. for working conditions	from -40°C (-40°F) to 100°C (212°F)				
Weight	aluminium	1.56 kg (3.44 lb)	3.01 kg (6.63 lb)	7.05 kg (15.54 lb)	6.32 kg (13.93 lb)
	steel	3.58 kg (7.89 lb)	6.65 kg (14.66 lb)	17.58 kg (38.76 lb)	14.97 kg (33.00 lb)

NOTE - For different conditions, please contact Walvoil Sales Dpt.

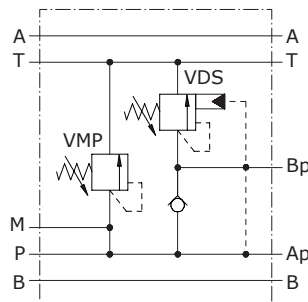

Dimensions

Dimensions are in mm-in

Valve type	A1	B1	ØY	C	D	E
VEP/FL 6-38	50	21.75	6,5	7	28.5	26.5
	1.97	0.86	0.25	0.27	1.12	1.04
VEP/FL 10-12	60	37	6.5	7	30	33
	2.36	1.46	0.25	0.27	1.18	1.30

Valve type	F	G	H	I	L	M1
VEP/FL 6-38	100	184.5	58	7	7	100
	3.94	7.26	2.28	0.27	0.27	3.94
VEP/FL 10-12	120	219	66	7	7	120
	4.72	8.62	2.60	0.27	0.27	4.72

Valve type	N	O	P	Q	R	S
VEP/FL 6-38	50	7	20	35	23	19
	1.97	0.27	0.79	1.38	0.91	0.75
VEP/FL 10-12	60	7	25	46	28	22
	2.36	0.27	0.98	1.81	1.10	0.87

Valve type	T1	U	V	W	X	X1	Z
VEP/FL 6-38	31	30	20	34	28	50	17
	1.22	1.18	0.79	1.34	1.10	1.97	0.67
VEP/FL 10-12	27	44	27	38	35	69	69
	1.06	1.73	1.06	1.50	1.38	2.71	2.71

Valve type	A-B	M	T	Ap	Bp
VEP/FL 6-38	G3/8	G1/4	G1/2	G1/4	G3/8
VEP/FL 10-12	G1/2	G1/4	G3/4	G3/8	G1/2

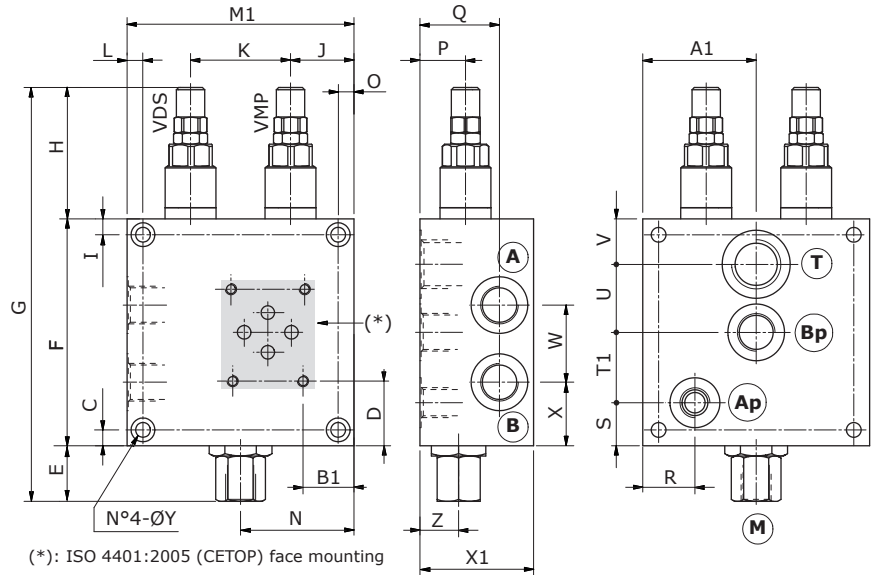

Valve type	A-B	M	T	Ap	Bp
VEP/FL 16-34	G3/4	G1/4	G1"	G1/2	G3/4

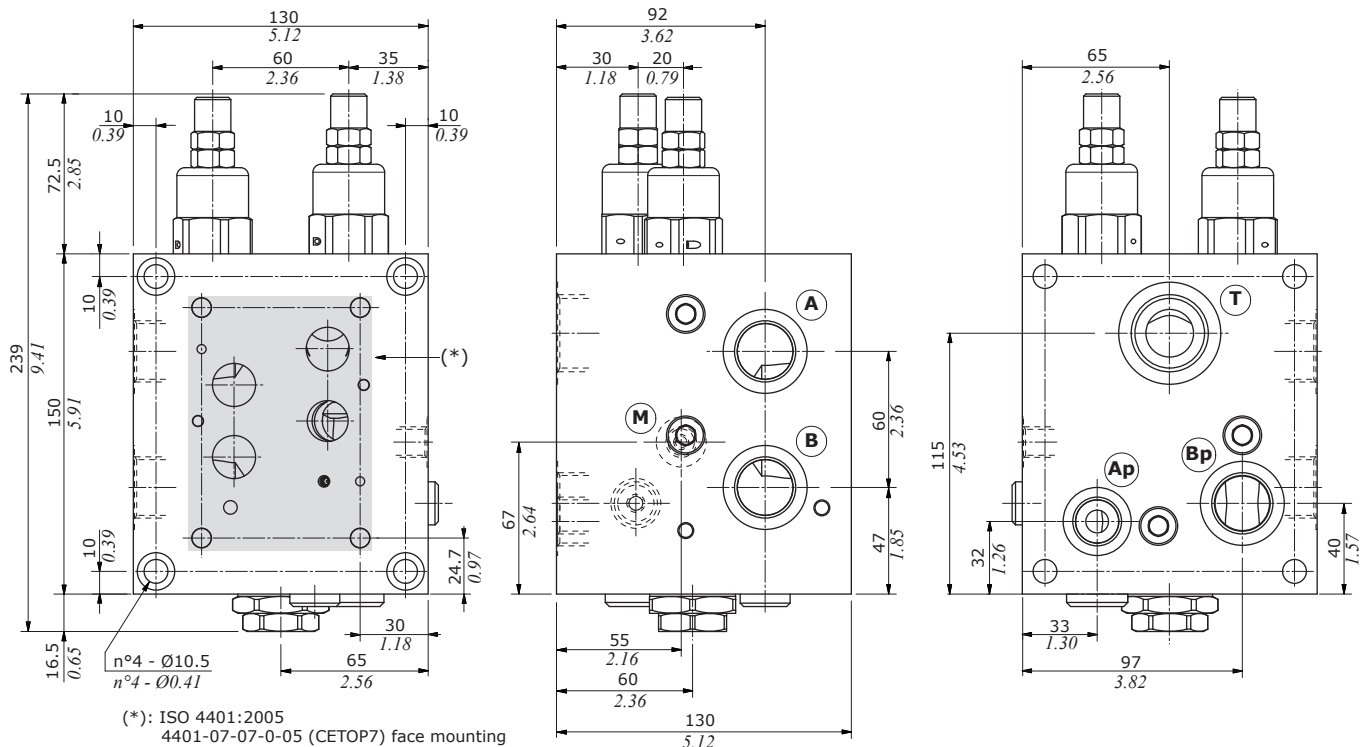

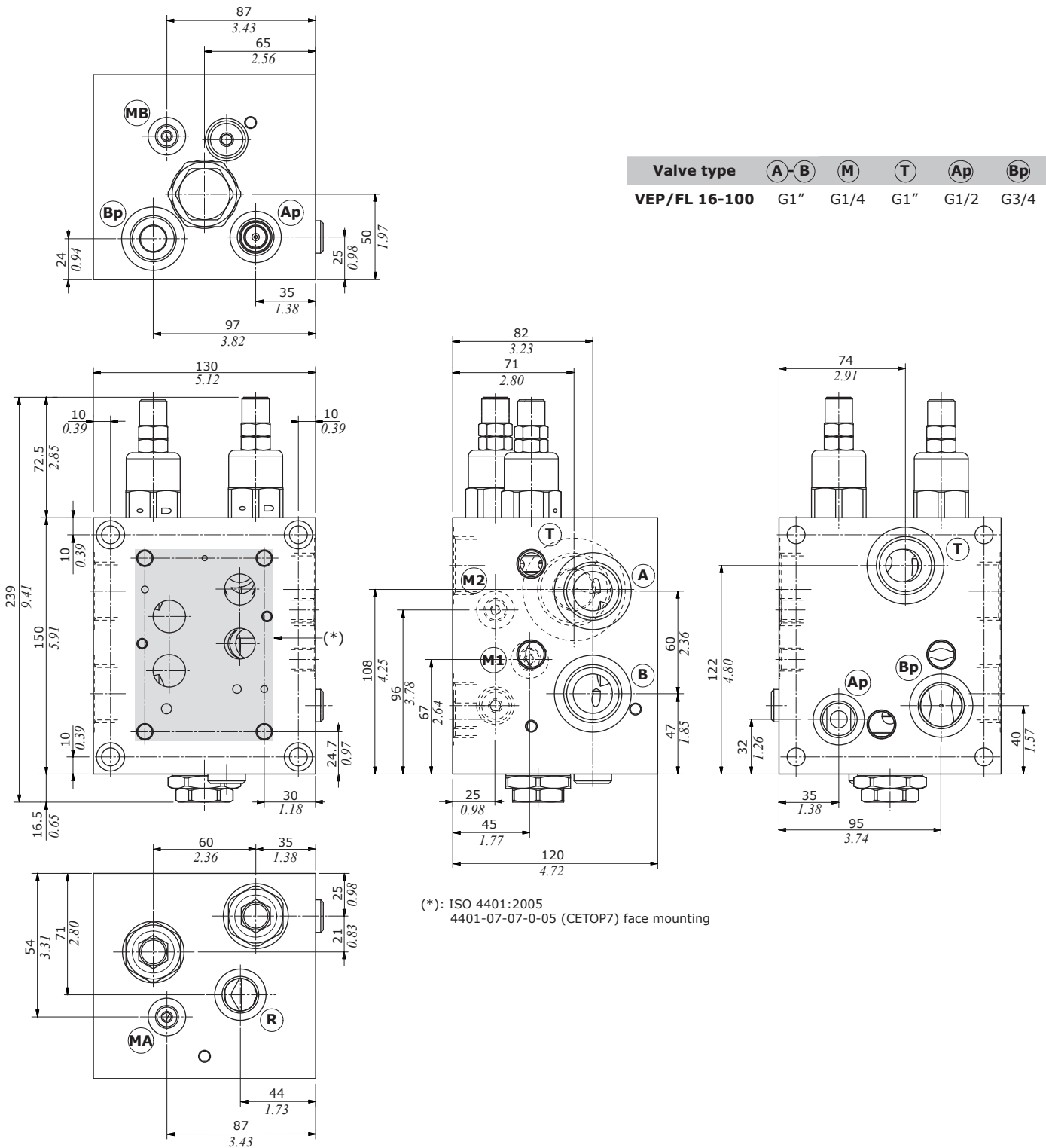

Ordering codes and description composition

Port size
VEP/FL 6-38/TR-TV.S

4 5

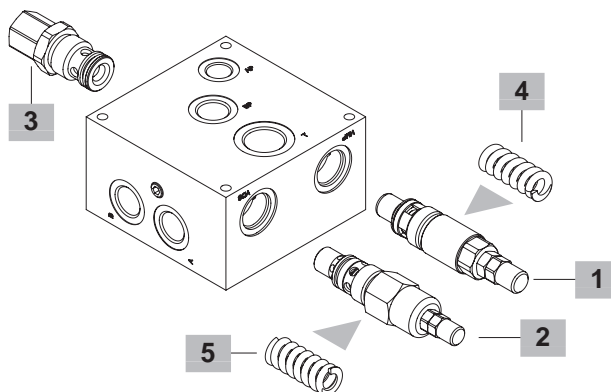

VEP/FL complete valves

Single type valve configuration

High pressure (Ap): range 180-350 bar (2600-5075 psi) and standard setting 280 bar (4060 psi) at 5 l/min (1.32 US gpm); Low Pressure (Bp): see below

Configuration with G3/8 standard thread

TYPE: **VEP/FL 6-38/TR-TV.S** CODE: 1224021101

DESCRIPTION: Aluminium body, Bp: range 20-80 bar (290-1160 psi), Standard setting 60 bar (870 psi) at 5l/min (1.32 US gpm)

TYPE: **VEP/FL 6-38/TR-TV.S/ac** CODE: 1224022100

DESCRIPTION: Steel body, as previous one

Configuration with G1/2 standard thread

TYPE: **VEP/FL 10-12/TR-TV.S** CODE: 1224031101

DESCRIPTION: Aluminium body, Bp: range 5-80 bar (72.5-1160 psi), standard setting 40 bar (870 psi) at 5l/min (1.32 US gpm)

TYPE: **VEP/FL 10-12/TR-TV.S/ac** CODE: 1224032100

DESCRIPTION: Steel body, as previous one

Configuration with G3/4 standard thread

TYPE: **VEP/FL 16-34/TR-TV.S** CODE: 1224041101

DESCRIPTION: Aluminium body, Bp: range 10-80 bar (145-1160 psi), standard setting 50 bar (725 psi) at 5 l/min (1.32 US gpm)

TYPE: **VEP/FL 16-34/TR-TV.S/ac** CODE: 1224042101

DESCRIPTION: Steel body, as previous one

Configuration with G1" standard thread

TYPE: **VEP/FL 16-100/TR-TB.S** CODE: 1224041151

DESCRIPTION: Aluminium body, Bp: range 10-50 bar (290-1160 psi), standard setting 30 bar (870 psi) at 5l/min (1.32 US gpm)

TYPE: **VEP/FL 16-100/TR-TB.S/ac** CODE: 1224042150

DESCRIPTION: Steel body, as previous one

For other steel body configurations, SAE threads and configurations with FPM (Viton) seals, please contact our Sales Dpt.

1 Direct acting pressure relief valve

Standard setting 160 bar at 5 l/min (2320 psi at 1.32 US gpm)

TYPE	CODE	DESCRIPTION
------	------	-------------

For G3/8 port configuration valve

VMP 5/TR.S 1100520401 Setting range 50-220 bar (725-3200 psi) (Ap)

For VEP 10-12 and VEP 16-34 valves

VMP 10/TR.S 1100530401 Setting range 50-220 bar (725-3200 psi) (Ap)

For VEP 16-100 valve

VMP 20/TR.S 1100540403 Setting range 50-220 bar (725-3200 psi) (Ap)

2 Sequence valve

Sequence cartridge setting range 20-80 bar (290-1150 psi) (Lp)

Standard setting 160 bar at 5 l/min (2320 psi at 1.32 US gpm)

TYPE	CODE	DESCRIPTION
VDS/VEP 38/TV.S	1205020400	For G3/8 port configuration
VDS/VEP 12/TV.S	1205030400	For G1/2 port configuration
VDS/VEP 34/TV.S	1205040405	For G3/4 port configuration
VDS/VEP 34/TB.S	1205040401	For G1" port configuration

3 Check valves

Opening pressure 0.5 bar

TYPE	CODE	DESCRIPTION
VUI 38/Pa0,5.man	1300020413	For G3/8 port configuration
VUI 12/Pa0,5 pass.magg.man	1300030402	For G1/2 port configuration
VUI 34/Pa0,5 pass.magg	1300040401	For G3/4 and G1" port configuration

4 Pressure relief valve setting springs

TYPE	CODE	DESCRIPTION
------	------	-------------

For VMP 5 valve on VEP/FL 6-38 complete valve (Ap)

TS	3MOL315330	Setting range 50-220 bar (725-3200 psi)
TR	3ML1143600	Setting range 180-350 bar (2600-5100 psi)

For VMP 10 valve on VEP/FL 10-12 complete valve (Ap)

TS	3MOL317420	Setting range 50-220 bar (725-3200 psi)
TR	3MOL317440	Setting range 180-350 bar (2600-5100 psi)

For VMP 20 valve on VEP/FL 16-34 and 16-100 complete valves (Ap)

TS	3ML1204200	Setting range 50-220 bar (725-3200 psi)
TR	3ML1214500	Setting range 180-350 bar (2600-5100 psi)

5 Sequence valve setting springs

TYPE	CODE	DESCRIPTION
------	------	-------------

For VDS/VEP 38 valve on VEP/FL 6-38 complete valve (Bp)

TB	3MOL314311	Setting range 5-40 bar (72.5-580 psi)
TV	3MOL314330	Setting range 20-80 bar (290-1150 psi)

For VDS/VEP 12 valve on VEP/FL 10-12 complete valve (Bp)

TV	3MOL317420	Setting range 5-80 bar (72.5-1150 psi)
-----------	------------	--

For VDS/VEP 34 valve on VEP/FL 16-34 and 16-100 complete valves (Bp)

TB	3ML1174500	Setting range 10-50 bar (145-725 psi)
TV	3ML1204200	Setting range 10-80 bar (145-1150 psi)

VEP/FL 6-38 pressure drop vs. flow from Bp→T and Bp→U

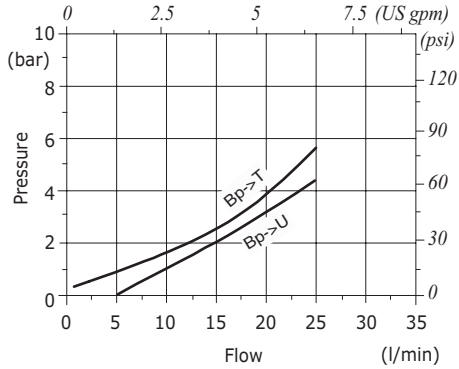

VEP/FL 6-38: VMP setting example at 5 l/min (1.32 US gpm)

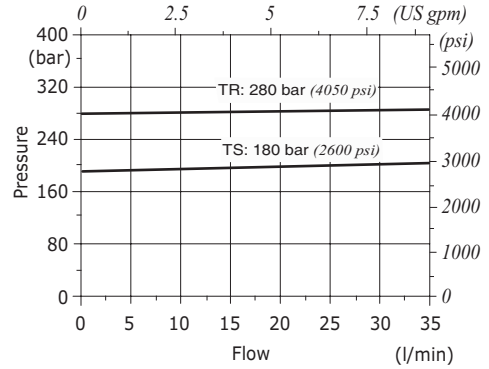

VEP/FL 10-12 pressure drop vs. flow from Bp→T and Bp→U

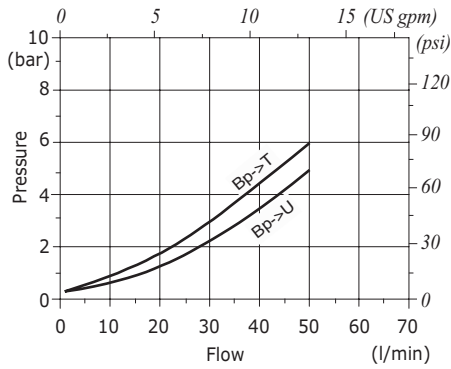

VEP/FL 10-12: VMP setting example at 5 l/min (1.32 US gpm)

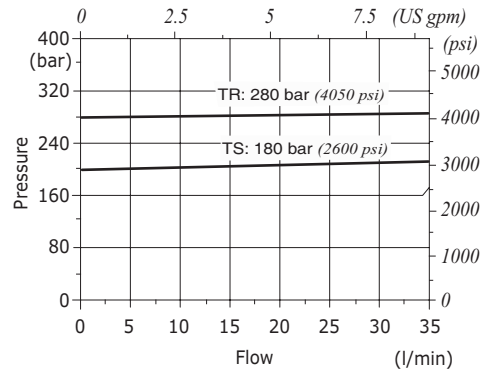

VEP/FL 16-34 pressure drop vs. flow from Bp→T and Bp→U

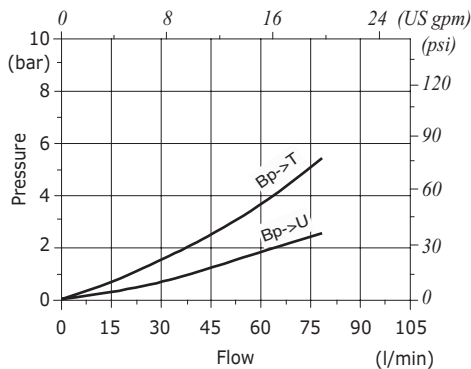

VEP/FL 100 pressure drop vs. flow from Bp→T and Bp→U

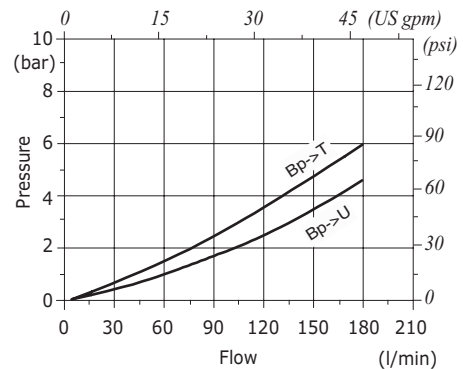

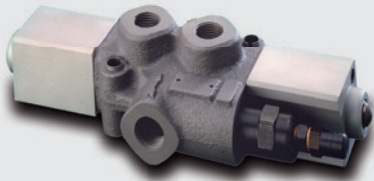

Type SD../IAM automatic reversing valves

- Mechanical control
- Cast iron body

Technical specifications and diagrams are measured with mineral oil of 46 cSt viscosity at 40°C (104°F) temperature.

	SD4/IAM 38-12	SD11/IAM 12
Nominal flow	35 l/min (9.2 US gpm)	65 l/min (17.2 US gpm)
Max. pressure	210 bar (3050 psi)	
Fluid	mineral based oil	
Viscosity	from 10 to 200 cSt	
Max. level of contamination	18/16/13 ISO4406	
Fluid temperature	with NBR seals from -20°C (-4°F) to 80°C (176°F)	
Environmental temp. for working conditions	from -40°C (-40°F) to 100°C (212°F)	
Weight	cast iron 2.45 kg (5.40 lb)	6.16 kg (13.58 lb)

NOTE - For different conditions, please contact Walvoil Sales Dpt.

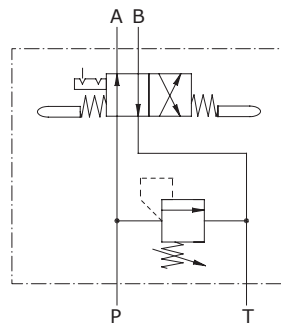

Dimensions

Valve type	All ports
SD4/IAM 38	G3/8
SD4/IAM 12	G1/2

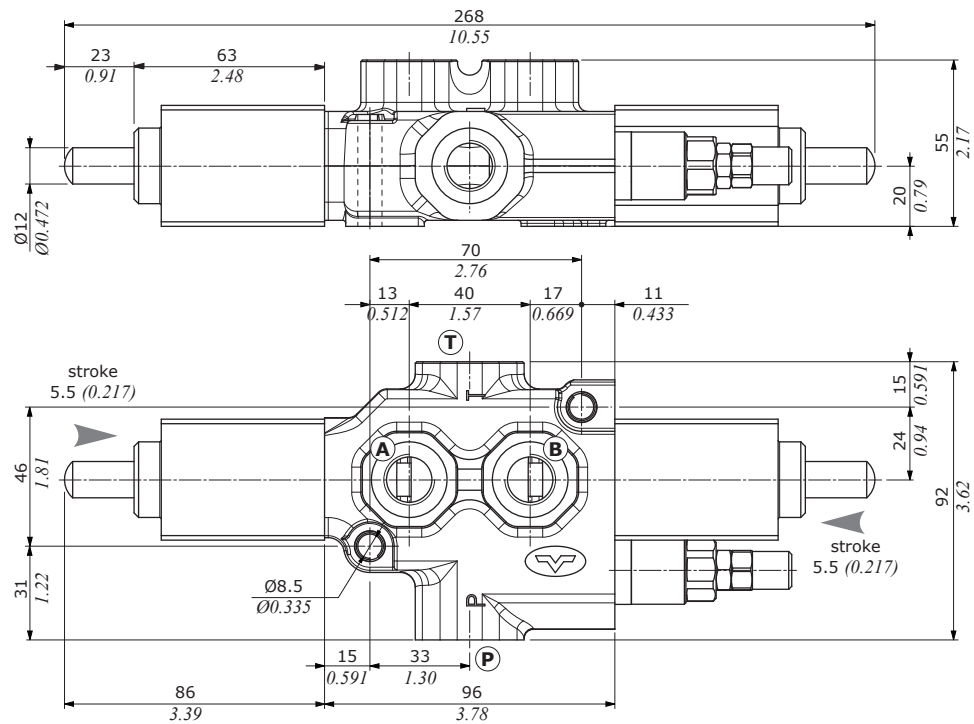

Valve type	P	A	B	T
SD11/IAM 12	G1/2	G1/2	G1/2	G3/4

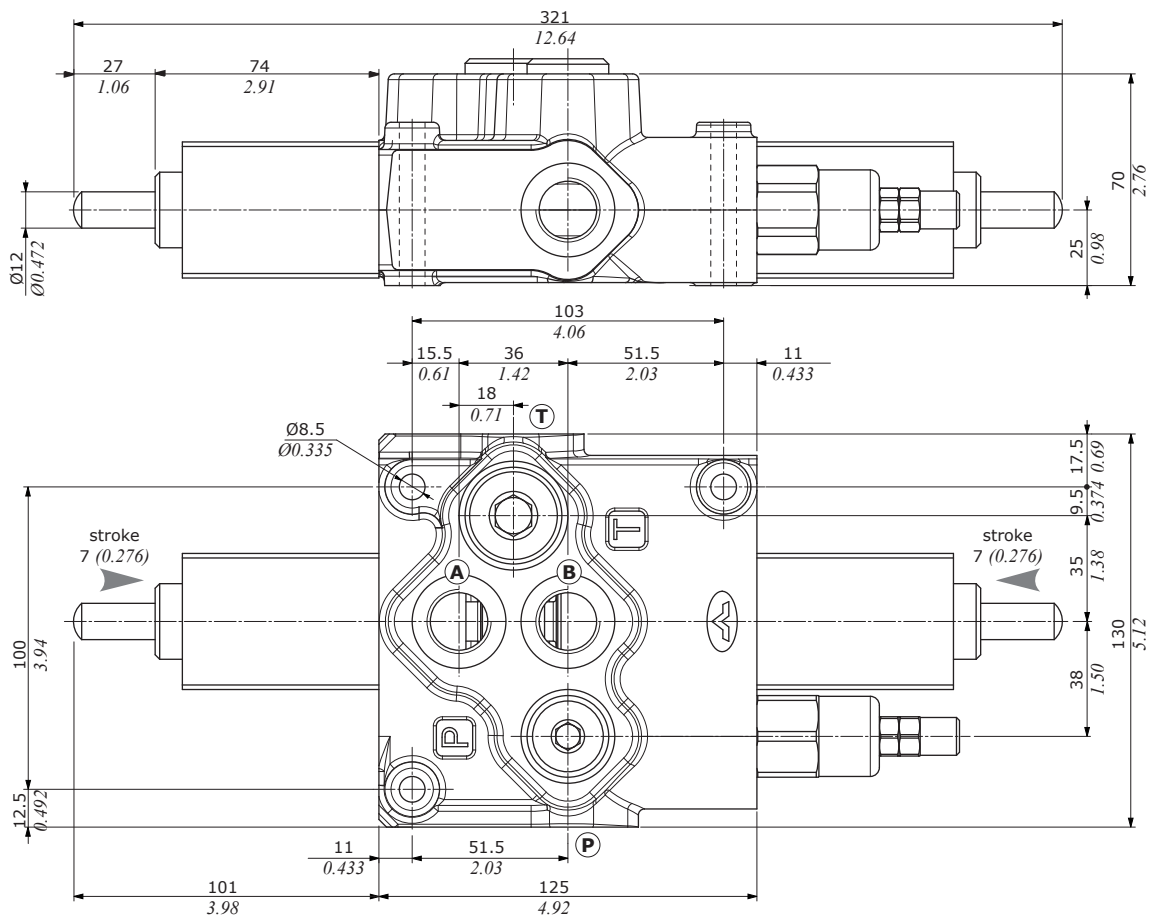

Ordering codes and description composition

Port size

SD4/IAM 38/VMP 5.TS.S/gh

2

1

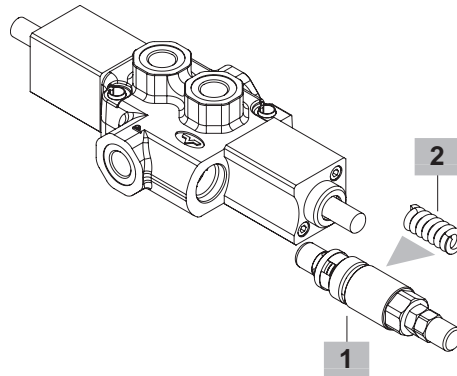

SD../IAM complete valves

Configuration with G3/8 ports

TYPE: **SD4/IAM 38/VMP 5.TS.S/gh** CODE: 1910023102
 DESCRIPTION: With pressure relief valve, range 50-220 bar (725-3200 psi), std. setting 160 bar @ 5 l/min (2320 psi @ 1.32 US gpm)
 TYPE: **SD4/IAM/SV 38/gh** CODE: 1910023103
 DESCRIPTION: Without pressure relief valve

Configuration with G1/2 ports

TYPE: **SD4/IAM 12/VMP 5.TS.S/gh** CODE: 1910023152
 DESCRIPTION: With pressure relief valve, range 50-220 bar (725-3200 psi) std. setting 160 bar @ 5 l/min (2320 psi @ 1.32 US gpm)
 TYPE: **SD11/IAM 12/VMP 10.TS.S/gh** CODE: 1910033102
 DESCRIPTION: With pressure relief valve, range 50-220 bar (725-3200 psi) std. setting 160 bar @ 5 l/min (2320 psi @ 1.32 US gpm)
 TYPE: **SD4/IAM/SV 12/gh** CODE: 1910023153
 DESCRIPTION: Without pressure relief valve
 TYPE: **SD11/IAM/SV 12/gh** CODE: 1910033103
 DESCRIPTION: Without pressure relief valve
 For different port threads configuration, SAE thread and configurations with FPM (Viton) seals, please contact our Sales Dpt.

1 Pressure relief valves

TYPE	CODE	DESCRIPTION
VMP 5/TS.S	1100520400	For SD4 valve, range 50-220 bar (725-3200 psi)
VMP 10/TS.S	1100530400	For SD11 valve, range 50-220 bar (725-3200 psi)

2 Pressure setting spring

TYPE	CODE	DESCRIPTION
For VMP 5 valve		
TB	3MOL314311	Setting range 5-40 bar (72.5-580 psi)
TV	3MOL314330	Setting range 20-80 bar (290-1160 psi)
TS	3MOL315330	Setting range 50-220 bar (725-3200 psi)
For VMP 10 valve		
TB	3MOL316410	Setting range 5-40 bar (72.5-580 psi)
TV	3ML1154300	Setting range 20-80 bar (290-1160 psi)
TS	3MOL317420	Setting range 50-220 bar (725-3200 psi)

Rating diagrams

SD4/IAM 38 pressure drop vs. flow

Std. setting at 5 l/min (1.32 US gpm)

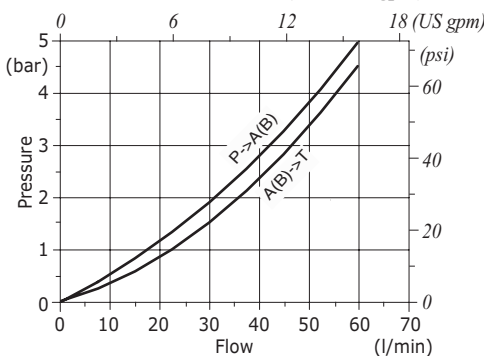

SD11/IAM 12 pressure drop vs. flow

Std. setting at 5 l/min (1.32 US gpm)

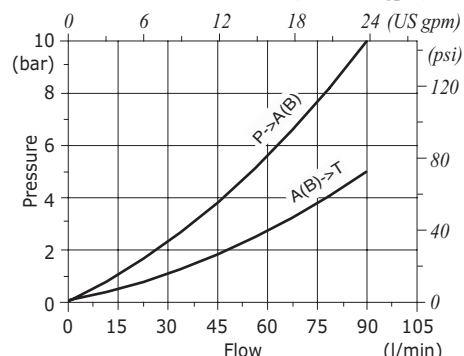

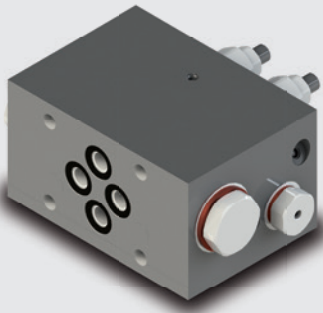

Type VIA/AP automatic reversing valves

- Face mounting cetop 3 (6-38) or cetop 5 (10-12)
- Cast iron body

Technical specifications and diagrams are measured with mineral oil of 46 cSt viscosity at 40°C (104°F) temperature.

	VIA/AP 6-38	VIA/AP 10-12
Nominal flow	30 l/min (7.9 US gpm)	60 l/min (15.9 US gpm)
Min. flow		4 l/min (1.06 US gpm)
Max. pressure		210 bar (3050 psi)
Max. reversing frequency		30/min
Fluid	mineral based oil	
Viscosity	from 10 to 200 cSt	
Max. level of contamination	18/16/13 ISO4406	
Fluid temperature	with NBR seals from -20°C (-4°F) to 80°C (176°F)	
Environmental temp. for working conditions	from -40°C (-40°F) to 100°C (212°F)	
Weight	cast iron 1.45 kg (3.20 lb)	2.31 kg (5.09 lb)

NOTE - For different conditions, please contact Walvoil Sales Dpt.

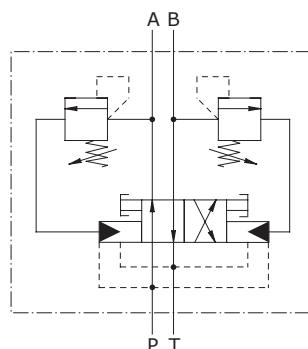

Dimensions

VIA/AP 6-38

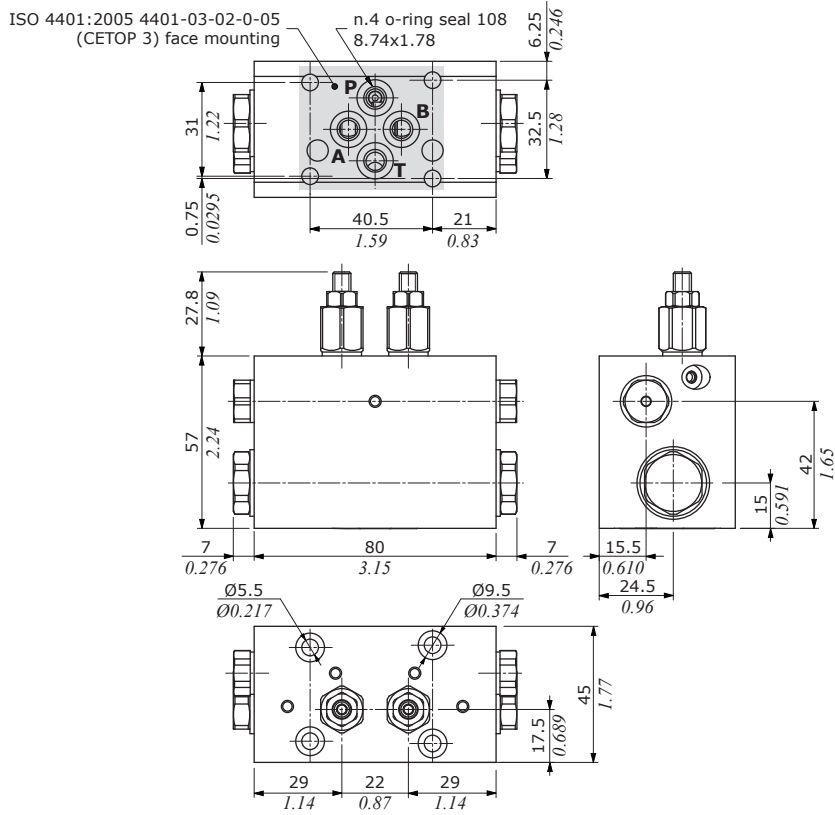

VIA/AP 10-12

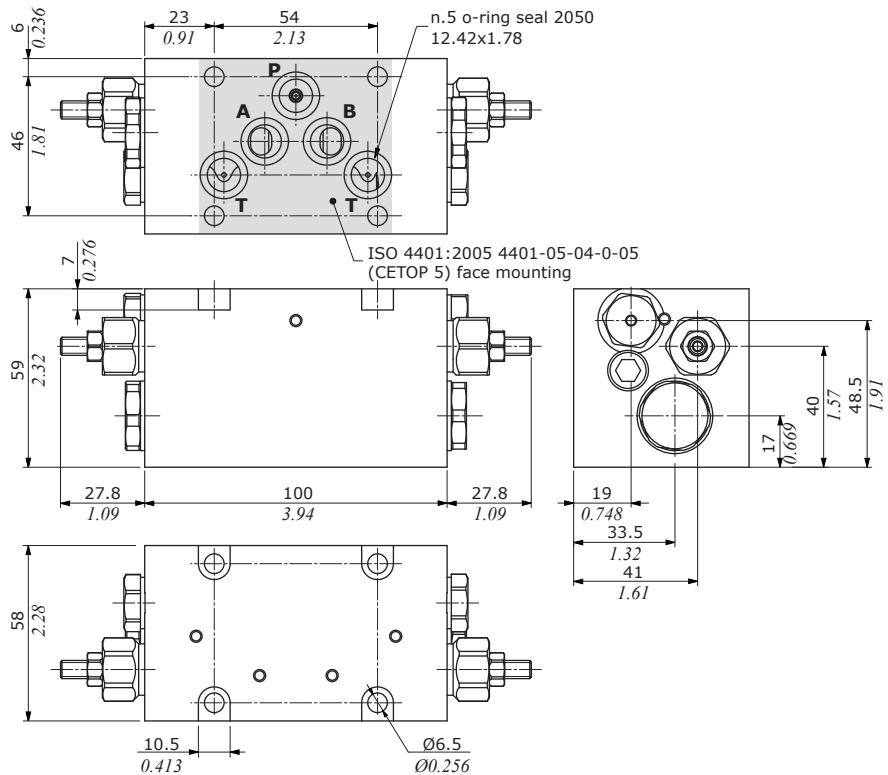

Ordering codes and description composition

VIA/AP 6-38/VMP01/TS.S/gh

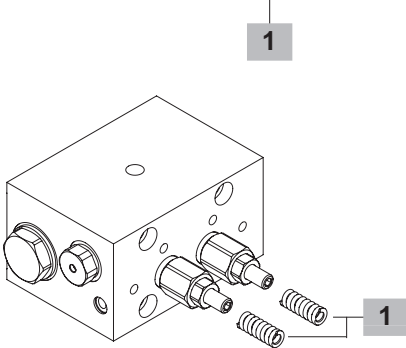

VIA/AP complete valves

VMP direct type valve configuration; range 50-220 bar (725-3200 psi), standard setting 150 bar @ 3 l/min (2175 psi @ 0.79 US gpm)

TYPE: **VIA/AP 6-38/VMP01/TS.S/gh** CODE: 1915023101

DESCRIPTION: Cast iron body,, CETOP 3 flange

TYPE: **VIA/AP 10-12/VMP02/TS.S/gh** CODE: 1915033101

DESCRIPTION: Cast iron body, CETOP 5 flange

For configurations with FPM (Viton) seals and SAE threads, please contact our Sales Dpt.

1 Pressure setting spring

TYPE	CODE	DESCRIPTION
For VIA/AP 6-38 valve		
TV	3ML1061900	Setting range 50-80 bar (72.5-1160 psi)
TS	3ML1071900	Setting range 50-220 bar (725-3200 psi)
For VIA/AP 10-12 valve		
TV	3ML1081400	Setting range 50-80 bar (72.5-1160 psi)
TS	3ML1081401	Setting range 50-220 bar (725-3200 psi)

For VIA/AP 6-38 valve

TV 3ML1061900 Setting range 50-80 bar (72.5-1160 psi)
 TS 3ML1071900 Setting range 50-220 bar (725-3200 psi)

For VIA/AP 10-12 valve

TV 3ML1081400 Setting range 50-80 bar (72.5-1160 psi)
 TS 3ML1081401 Setting range 50-220 bar (725-3200 psi)

VIA/AP 10-12/VMP02/TS.S/gh

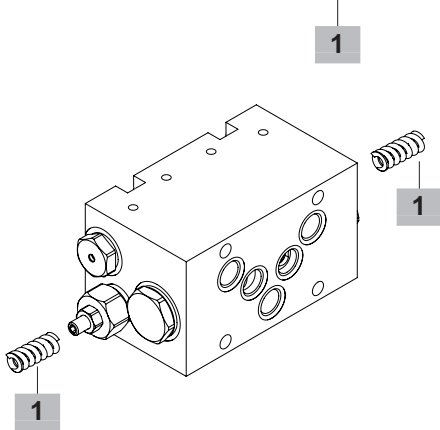

Rating diagrams

VIA/AP 6-38 pressure drop vs. flow

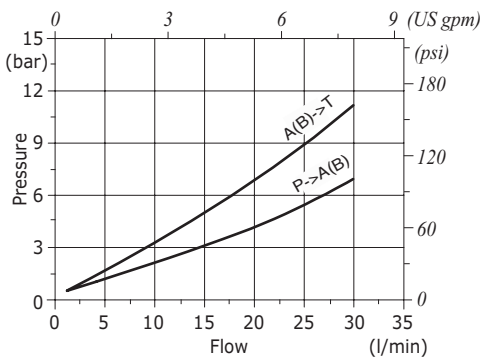

VIA/AP 10-12 pressure drop vs. flow

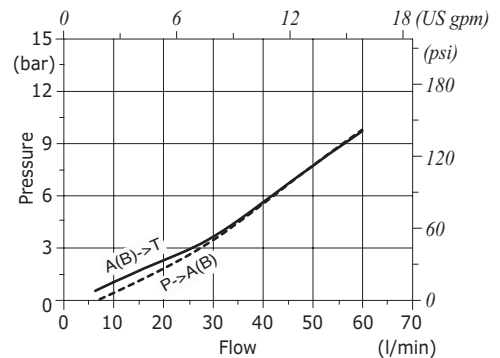



Type VIA/AP 12/L/CMEB automatic reversing valves

- Mechanical and hydraulic control
- Cast iron body

Technical specifications and diagrams are measured with mineral oil of 46 cSt viscosity at 40°C (104°F) temperature.

VIA/AP 12/L/CMEB	
Nominal flow	60 l/min (15.9 US gpm)
Min. flow	4 l/min (1.06 US gpm)
Max. pressure	210 bar (3050 psi)
Max. reversing frequency	30/min
Fluid	mineral based oil
Viscosity	from 10 to 200 cSt
Max. level of contamination	18/16/13 ISO4406
Fluid temperature	with NBR seals from -20°C (-4°F) to 80°C (176°F)
Environmental temp. for working conditions	from -40°C (-40°F) to 100°C (212°F)
Weight	cast iron 5.2 kg (11.46 lb)

NOTE - For different conditions, please contact Walvoil Sales Dpt.

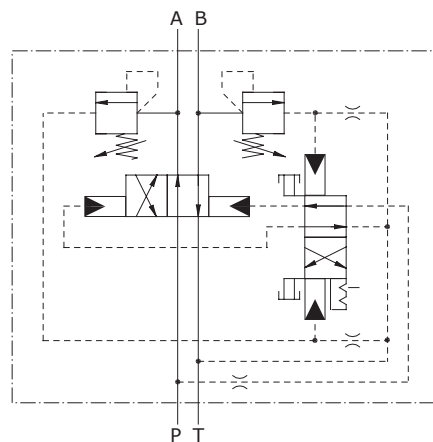

Dimensions

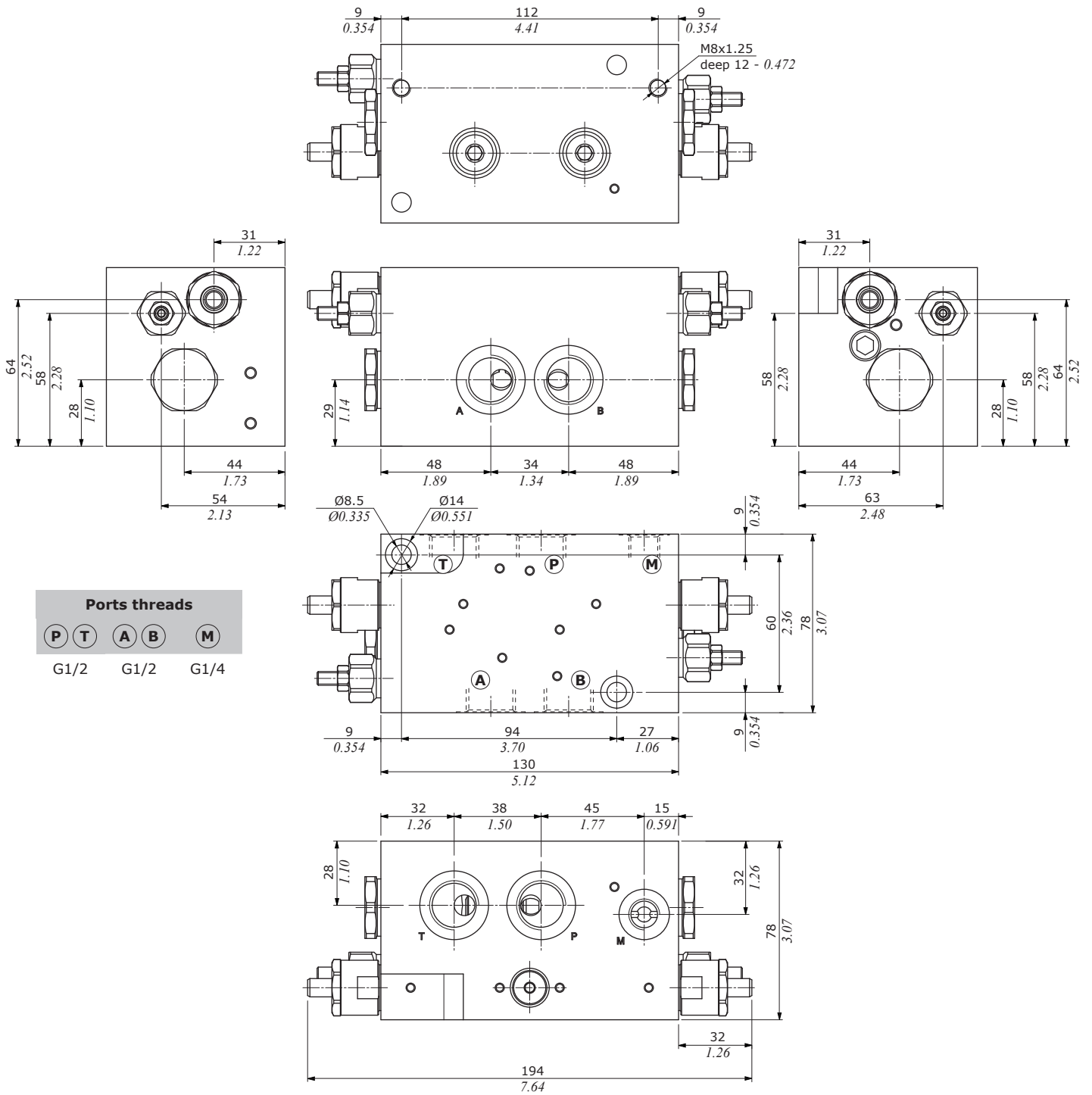

Ordering codes and description composition

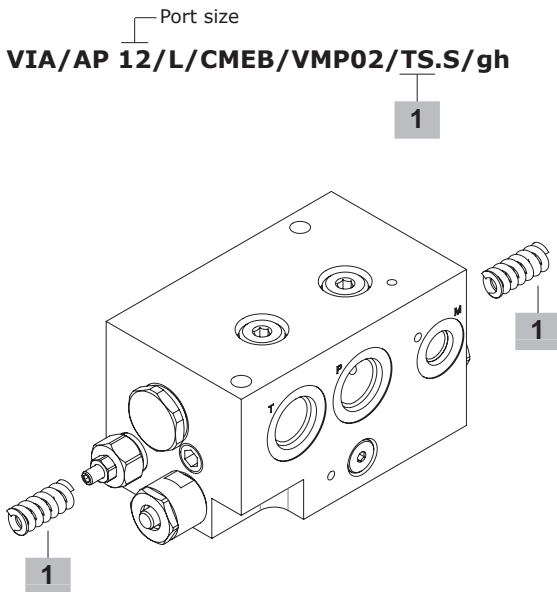

Complete valves

TYPE: **VIA/AP 12/L/CMEB/VMP02/TS.S/gh** CODE: 1915033904
 DESCRIPTION: Cast iron body, G1/2 ports, with direct type pressure relief valves, range 50-220 bar (725-3200 psi), standard setting 150 bar at 3 l/min (2175 psi at 0.79 US gpm)
 For different port threads configuration, SAE thread and configurations with FPM (Viton) seals, please contact our Sales Dpt.

1 Pressure setting spring

TYPE	CODE	DESCRIPTION
TV	3ML1081400	Setting range 5-80 bar (72.5-1160 psi)
TS	3ML1081401	Setting range 50-220 bar (725-3200 psi)

Rating diagrams

Pressure drop vs. flow

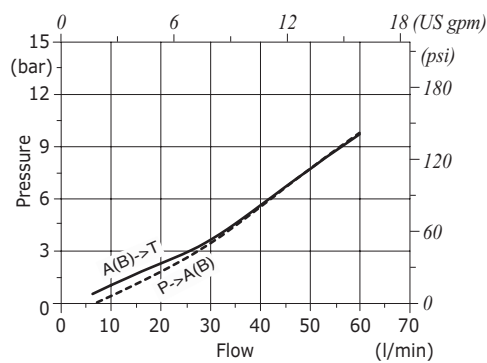



Type VIA/DSL automatic reversing valves

- Face mounting cetop 5
- Cast iron body

Technical specifications and diagrams are measured with mineral oil of 46 cSt viscosity at 40°C (104°F) temperature.

VIA/DSL 10-12

Nominal flow	60 l/min (15.9 US gpm)
Min. flow	10 l/min (2.6 US gpm)
Max. pressure	210 bar (3050 psi)
Max. reversing frequency	30/min
Fluid	mineral based oil
Viscosity	from 10 to 200 cSt
Max level of contamination	18/16/13 ISO4406
Fluid temperature	with NBR seals from -20°C (-4°F) to 80°C (176°F)
Environmental temp. for working conditions	from -40°C (-40°F) to 100°C (212°F)
Weight	2.2 kg (4.85 lb) with stroke limiter configuration: 2.3 kg (5.07 lb)
	<i>cast iron</i>

NOTE - For different conditions, please contact Walvoil Sales Dpt.

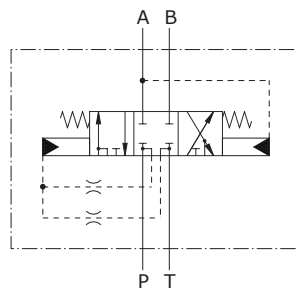

With stroke limiter

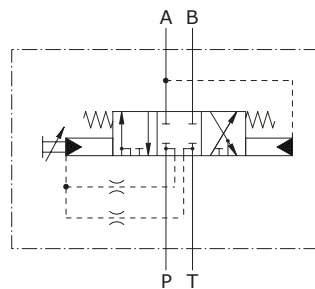

Dimensions

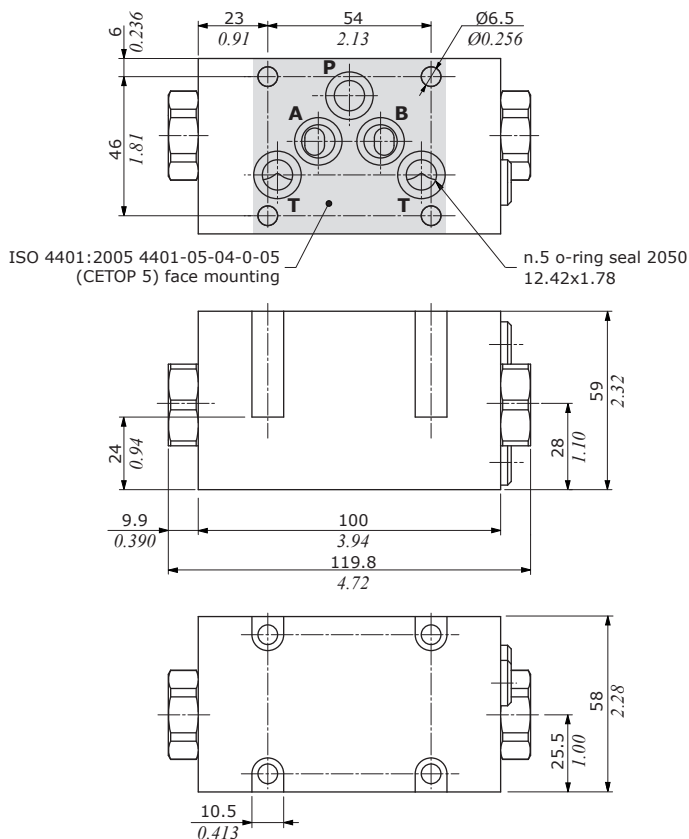

Ordering codes and description composition

VIA/DSL 10-12/gh

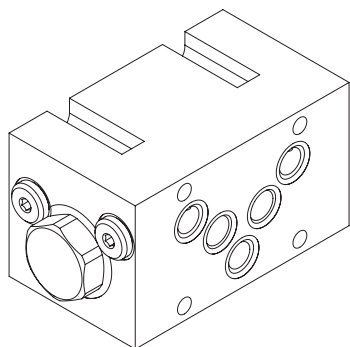

Complete valves

TYPE: **VIA/DSL 10-12/gh**

CODE: 1915033903

DESCRIPTION: Cast iron body, CETOP 5 flange

TYPE: **VIA/DSL 10-12/gh pass.magg. con fine corsa**

CODE: 1915033910

DESCRIPTION: cast iron body, increased spool, with stroke limiter
 For configurations with FPM (Viton) seals and SAE threads, please
 contact our Sales Dpt.

Types and ordering codes

Coil type	Voltage	Connectors					
		ISO4400	Deutsch DT	AMP JPT	Packard Weatherpack	Packard Metri-pack	Flying leads (without conn.)
BER	10 VDC	4SLE001000A	-	-	-	-	-
	12 VDC	4SLE001200A	4SLE001201A ⁽⁵⁾	4SLE001203A ⁽⁵⁾	4SLE001210A ⁽²⁾	4SLE001214A ⁽²⁾	4SLE001207A
		4SLE001217A ⁽³⁾	4SLE001209A ⁽³⁻⁵⁾	4SLE001211A ⁽³⁻⁵⁾	-	-	-
		-	4SLE001202A ⁽⁶⁾	-	-	-	-
		-	4SLE001216A ⁽³⁻⁶⁾	-	-	-	-
	14 VDC	-	4SLE001400A ⁽⁶⁾	4SLE001403A ⁽³⁻⁵⁾	-	-	-
	24 VDC	4SLE002400A	4SLE001401A ⁽³⁻⁶⁾	-	-	-	-
		4SLE002408A ⁽³⁾	4SLE001402A ⁽³⁻⁵⁾	4SLE002403A ⁽⁵⁾	-	-	4SLE002404A
28 VDC	-	4SLE002407A ⁽³⁻⁵⁾	-	-	-	-	
48 VDC	4SLE002400A ⁽¹⁾	4SLE002402A ⁽⁶⁾	4SLE002800A ⁽⁵⁾	-	-	-	
110VDC	4SLE004800A	-	-	-	-	-	
220 VDC	4SLE311000A ⁽¹⁾	-	-	-	-	-	
BT	10 VDC	4SL3000100	-	-	-	-	-
	12 VDC	4SL3000120	4SL3000130 ⁽⁶⁾	4SL3000122 ⁽⁵⁾	4SL3000124 ⁽²⁾	4SL3000127 ⁽²⁾	4SL300012C
		4SL3000126 ⁽⁴⁾	4SL3000134 ⁽³⁻⁶⁾	4SL3001200 ⁽³⁻⁵⁾	-	-	-
		-	4SL3000128 ⁽²⁾	-	-	-	-
	24 VDC	4SL3000240	4SL3000249 ⁽⁶⁾	4SL3000248 ⁽⁵⁾	-	-	4SL3000246
	26 VDC	4SL3030240 ⁽¹⁾	4SL300024C ⁽³⁻⁶⁾	-	-	-	-
	48 VDC	4SL3000260	-	-	-	-	-
	110 VDC	4SL3000480	-	-	-	-	-
220 VDC	4SL3030480 ⁽¹⁾	-	-	-	-	-	
Mating connectors	Standard	4SL3001100	-	-	-	-	-
	220 VDC	4SL3032200 ⁽¹⁾	-	-	-	-	-
With rectifier	Standard	4CN1009995	5CON140031	5CON003	5CON001	5CON017	-
	24VDC	4CN3010240	-	-	-	-	-
	48VDC	4CN3010480	-	-	-	-	-
	110VDC	4CN3011100	-	-	-	-	-
	220VDC	4CN3012200	-	-	-	-	-

NOTES: ⁽¹⁾ supply with AC and use only with rectifier connector - ⁽²⁾ with flying leads - ⁽³⁾ with bidirectional diode - ⁽⁴⁾ with unidirectional diode
⁽⁵⁾ integrated perpendicular type - ⁽⁶⁾ integrated parallel type

Dimensional data and features

BER type

ISO4400 connector

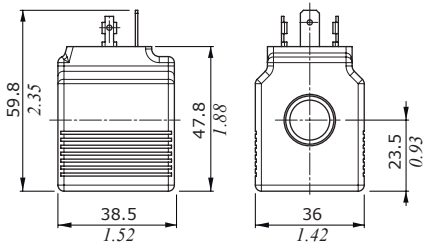

AMP JPT connector

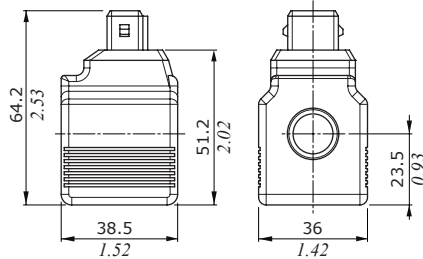

Features

- Nominal voltage tolerance : $\pm 10\%$
- Power rating : 19.2 W - 12/24 VDC
48 RAC
: 19.1 W - 28 VDC
: 19 W - 10/14/48/110/
220 VDC
24/110/220 RAC
- Max. operating current . . : 1.90 A - 10 VDC
: 1.60 A - 12 VDC
: 1.36 A - 14 VDC
: 0.80 A - 24 VDC
: 0.68 A - 28 VDC
: 0.40 A - 48 VDC
: 0.17 A - 110 VDC
: 0.09 A - 220 VDC
: 0.89 A - 24 RAC
: 0.45 A - 48 RAC
: 0.19 A - 110 RAC
: 0.09 A - 220 RAC
- Coil insulation : Class H (180°C - 356°F)
- Weather protection : IP65 - ISO4400
: IP69K - Deutsch DT
: IP65 - AMP JPT
: IP67 - Weatherpack
: IP67 - Metri-pack
- Insertion : 100%

DEUTSCH DT04 connector
(parallel type)

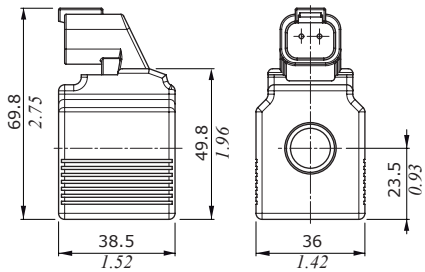

DEUTSCH DT04 connector
(perpendicular type)

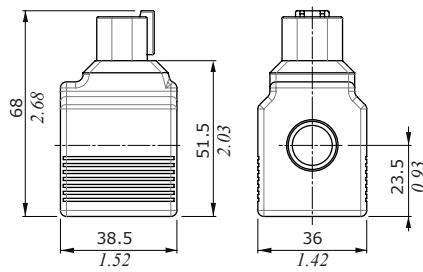

Flying leads

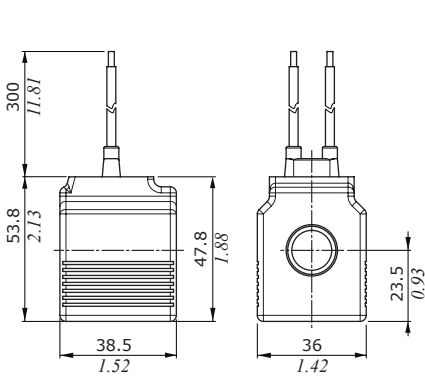

Flying leads with DEUTSCH DT04 connector

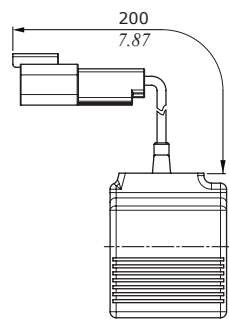

Flying leads with PACKARD WEATHER-PACK connector

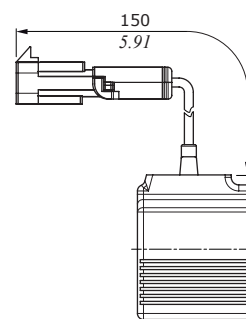

Flying leads with PACKARD METRI-PACK connector

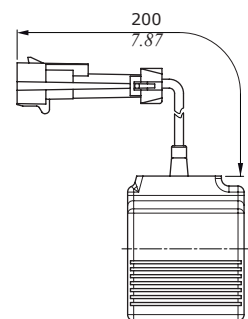

Gauge isolator

Technical specifications are measured with mineral oil ISO VG32 at 50°C (122°F) temperature.

		EMIL 01			EM90 01		
		type A	type B	type C	type A	type B	type C
Max. flow				5 l/min (1.3 US gpm)			
Max. pressure				350 bar (5100 psi)			
Fluid				mineral based oil			
Viscosity				from 10 to 200 cSt			
Max. level of contamination				18/16/13 ISO4406			
Fluid temperature				with NBR seals from -20°C (-4°F) to 80°C (176°F)			
Environmental temp. for working conditions				from -40°C (-40°F) to 100°C (212°F)			
Material				zinc plated brass			
Weight	steel	0.125 kg (0.276 lb)	0.140 kg (0.309 lb)	0.145 kg (0.320 lb)	0.123 kg (0.271 lb)	0.123 kg (0.271 lb)	0.123 kg (0.271 lb)

NOTE - For different conditions and thread, please contact Walvoil Sales Dpt.

EMIL 01 A
(male / turning female)

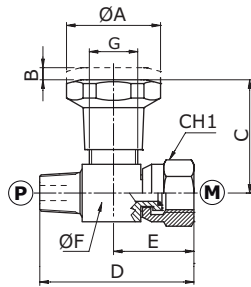

EMIL 01 B
(female / turning female)

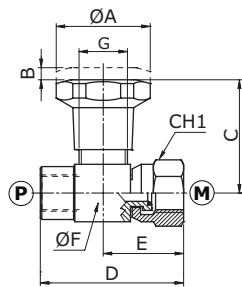

EMIL 01 C
(turning female / turning female)

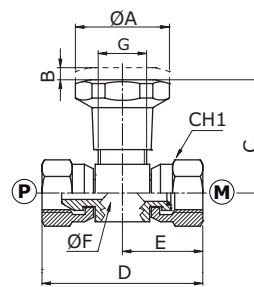

D
panel mounting nut
on request

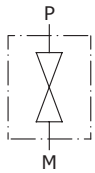
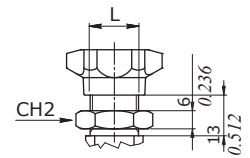

Dimensions are in mm-in

Valve type	(P)	(M)	ØA	B	C	D	E	ØF	G	CH1	CH2	Ordering code
EMIL01A	R1/4	G1/4	32-1.26	4-0.157	38-1.50	50-1.97	27-1.06	19-0.75	M16x1.5	19	22	1608010100
EMIL01B	G1/4	G1/4	32-1.26	4-0.157	38-1.50	48-1.89	27-1.06	19-0.75	M16x1.5	19	22	1608010101
EMIL01C	G1/4	G1/4	32-1.26	4-0.157	38-1.50	50-1.97	27-1.06	19-0.75	M16x1.5	19	22	1608010102

EM90 01 A
(male / turning female)

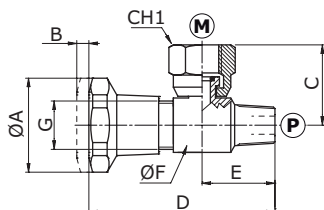

EM90 01 B
(female / turning female)

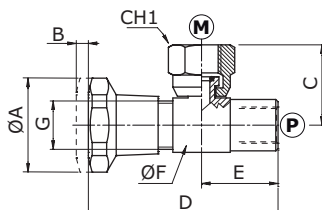

EM90 01 C
(turning female / turning female)

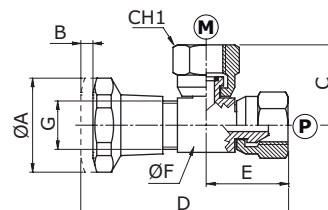

D
panel mounting nut
on request

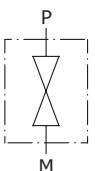
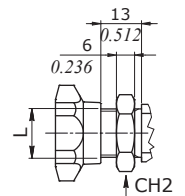

Dimensions are in mm-in

Valve type	(P)	(M)	ØA	B	C	D	E	ØF	G	CH1	CH2	Ordering code
EM9001A	R1/4	G1/4	32-1.26	4-0.157	26.5-1.04	60-2.36	24-0.94	19-0.75	M16x1.5	19	22	1608110100
EM9001B	G1/4	G1/4	32-1.26	4-0.157	26.5-1.04	58-2.28	22-0.87	19-0.75	M16x1.5	19	22	1608110101
EM9001C	G1/4	G1/4	32-1.26	4-0.157	26.5-1.04	62-2.44	26-1.02	19-0.75	M16x1.5	19	22	1608110102

Throttle valve

Technical specifications are measured with mineral oil ISO VG32 at 50°C (122°F) temperature.

	VTS 01	VTS 02
Max. flow		30 l/min (7.9 US gpm)
Max. pressure		350 bar (5100 psi)
Fluid		mineral based oil
Viscosity		from 10 to 200 cSt
Max. level of contamination		18/16/13 ISO4406
Fluid temperature	with NBR seals from -20°C (-4°F) to 80°C (176°F)	
Environmental temp. for working conditions	from -40°C (-40°F) to 100°C (212°F)	
Material	steel	
Weight	0.048 kg (0.106 lb)	0.076 kg (0.172 lb)

NOTE - For different conditions and thread, please contact Walvoil Sales Dpt.

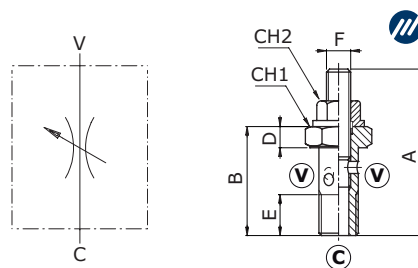

Dimensions are in mm-in

Valve type	(V)	(C)	A	B	D	E	F	CH1	CH2	Ordering code
VTS 01	Ø3 Ø0.118	G1/4	60 2.36	36 1.42	7 0.276	13.5 0.531	M8	19	13	
VTS 02	Ø4 Ø0.157	G3/8	63 2.48	39 1.54	8 0.315	16 0.630	M8	22	13	

Rotary coupling

Technical specifications are measured with mineral oil ISO VG32 at 50°C (122°F) temperature.

GGIL - GG90									
	01	02	03	04	05	06	07	09	
Max. flow	25 l/min (6.6 US gpm)	45 l/min (11.9 US gpm)	80 l/min (21.1 US gpm)	120 l/min (31.7 US gpm)	150 l/min (39.6 US gpm)	200 l/min (52.8 US gpm)	250 l/min (66 US gpm)	300 l/min (79.3 US gpm)	
Max. pressure	400 bar (5800 psi)	400 bar (5800 psi)	360 bar (5200 psi)	310 bar (1500 psi)	280 bar (5800 psi)	250 bar (3600 psi)	210 bar (3050 psi)	180 bar (2600 psi)	
Fluid	mineral based oil								
Viscosity	from 10 to 200 cSt								
Max. level of contamination	18/16/13 ISO4406								
Fluid temperature	with NBR seals from -20°C (-4°F) to 80°C (176°F)								
Environmental temp. for working conditions	from -40°C (-40°F) to 100°C (212°F)								
Material	zinc plated steel								
Max. rotation speed	500 rpm	400 rpm	370 rpm	280 rpm	230 rpm	200 rpm	170 rpm	140 rpm	
Weight	GGIL	0.21 kg (0.463 lb)	0.30 kg (0.661 lb)	0.33 kg (0.106 lb)	0.54 kg (0.728 lb)	1.03 kg (2.27 lb)	1.14 kg (2.51 lb)	1.68 kg (3.70 lb)	2.52 kg (5.56 lb)
	GG90	0.28 kg (0.617 lb)	0.40 kg (0.882 lb)	0.55 kg (1.21 lb)	1.05 kg (2.31 lb)	1.45 kg (3.20 lb)	1.83 kg (4.03 lb)	3.00 kg (6.61 lb)	3.54 kg (7.80 lb)

NOTE - For different conditions and thread, please contact Walvoil Sales Dpt.



from 01 to 04

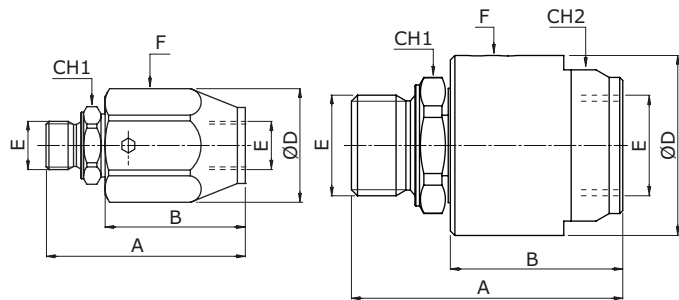

Dimensions are in mm-in

Coupling type	A	B	ØD	E	F	CH1	CH2	Ordering code
GGIL01	63 2.48	42 1.65	33 1.30	G1/4	∅30	19	/	1800010100
GGIL02	66 2.60	45 1.77	37 1.46	G3/8	∅34	24	/	1800020100
GGIL03	73 2.87	50 1.97	40 1.57	G1/2	∅36	27	/	1800030100
GGIL04	80 3.15	50 1.97	49 1.93	G3/4	∅45	34	/	1800040100
GGIL05	90 3.54	57 2.24	60 2.36	G1"	∅60 ∅2.36	41	50	1800050100
GGIL06	98 3.86	63 2.48	60 2.36	G1"1/4	∅60 ∅2.36	50	55	1800060100
GGIL07	107 4.21	70 2.76	70 2.76	G1"1/2	∅70 ∅2.76	55	65	1800070100
GGIL09	112 4.41	75 2.95	80 3.15	G2"	∅80 ∅3.15	70	75	1800090100



from 01 to 05

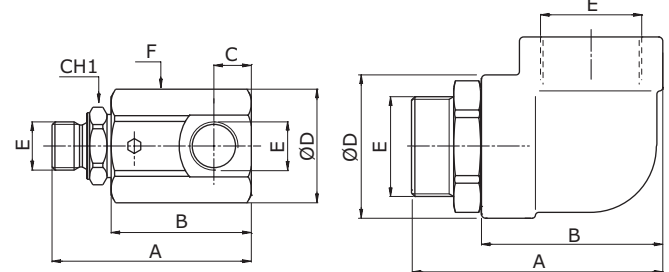

Dimensions are in mm-in

Coupling type	A	B	C	ØD	E	F	CH1	Ordering code
GG9001	71 2.80	72 2.83	11 0.433	33 1.30	G1/4	∅30	19	1800510100
GG9002	77 3.03	76.5 3.01	15 0.591	37 1.46	G3/8	∅34	24	1800520100
GG9003	86 3.39	87 3.43	17 0.669	40 1.57	G1/2	∅38	27	1800530100
GG9004	100 3.94	99.5 3.92	19 0.748	49 1.93	G3/4	∅50	34	1800540100
GG9005	113 4.45	115.5 4.55	23 0.91	60 2.36	G1"	∅59.5 ∅2.43	41	1800550100
GG9006	118 4.65	123 4.84	32 1.26	63 2.48	G1"1/4	/	50	1800560100
GG9007	138 5.43	138 5.43	38 1.50	76 2.99	G1"1/2	/	55	1800570100
GG9009	152 5.98	152 5.98	43 1.69	85 3.35	G2"	/	70	1800590100

OCC coupling
(zinc plated steel)

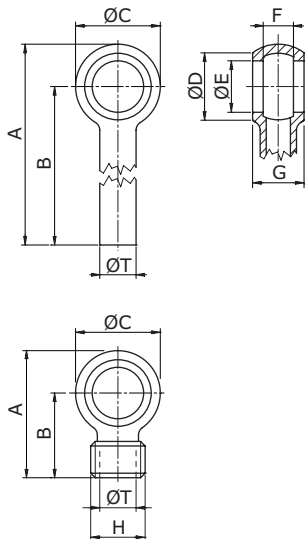

Dimensions are in mm-in

Part type	A	B	ØC	ØD	ØE	F	G	H	ØT	Weight Kg - lb	Ordering code
402023	52	40	24	17	13 (1/4)	14	10	/	12	0.036	
	2.05	1.57	0.94	0.669	0.512	0.551	0.394	/	0.472	0.079	
402026	212	200	24	17	13 (1/4)	14	10	/	12	0.107	
	8.35	7.87	0.94	0.669	0.512	0.551	0.394	/	0.472	0.236	
402027	412	400	24	17	13 (1/4)	14	10	/	12	0.185	
	16.22	15.75	0.94	0.669	0.512	0.551	0.394	/	0.472	0.408	
402021	414	400	28	22	16.9 (3/8)	17	10	/	12	0.193	
	16.30	15.75	1.10	0.87	0.665	0.669	0.394	/	0.472	0.425	
402014	54	40	28	22	16.9 (3/8)	17	10	/	12	0.043	
	2.13	1.57	1.10	0.87	0.665	0.669	0.394	/	0.472	0.472	
402015	214	200	28	22	16.9 (3/8)	17	10	/	12	0.115	
	8.43	7.87	1.10	0.87	0.665	0.669	0.394	/	0.472	0.254	
402017	42	28	28	22	16.9 (3/8)	17	10	M18x1.5	12	0.043	
	1.65	1.10	1.10	0.87	0.665	0.669	0.394	M18x1.5	0.472	0.472	
402031	217	200	35	28	21 (1/2)	21	15	/	15	0.162	
	8.54	7.87	1.38	1.10	0.83	0.83	0.591	/	0.591	0.357	

VT hollow bolt

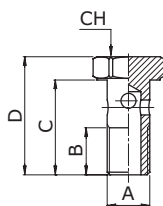

Dimensions are in mm-in

Part type	A	B	C	D	CH	Weight Kg - lb	Ordering code
402040	G1/4	13	26	33	19	0.030	
		0.512	1.02	1.30		0.067	
402041	G3/8	15	31	39	22	0.056	
		0.591	1.22	1.54		0.123	
402043	G1/2	18	38	46	27	0.087	
		0.709	1.50	1.81		0.192	

RON bonded seal

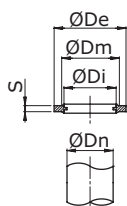

Dimensions are in mm-in

Part type	Dn	De	Di	Dm	S	Breaking pressure bar - psi	Pcs in package	Ordering code
440074	G1/8	15.9	10.4	11.85	2	1500	100	
		0.626	0.409	0.467	0.079	21750		
440068	G1/4	20.6	13.75	15.2	2	1550	100	
		0.78	0.541	0.60	0.079	22450		
440045	G3/8	23.8	17.3	18.75	2	1260	100	
		0.94	0.681	0.738	0.079	18250		
440070	G1/2	28.6	21.55	23	2.5	1150	100	
		1.13	0.848	0.91	0.098	16650		
440093	G5/8	31.8	23.5	25	2.5	1250	100	
		1.25	0.93	0.98	0.098	18100		
440075	G3/4	34.95	27.1	28.5	2.5	1060	100	
		1.38	1.07	1.12	0.098	15350		
440069	G1"	42.8	33.9	36.9	2.5	790	50	
		1.69	1.33	1.45	0.098	11450		
440076	G1"1/4	52.4	43	46	3.2	690	25	
		2.06	1.69	1.81	0.126	10000		
440077	G1"1/2	58.6	48.5	51.4	3.2	690	25	
		2.31	1.91	2.02	0.126	10000		
440078	G2"	73	60.5	63.7	3.2	700	25	
		2.87	2.38	2.51	0.126	10150		

NOTE - For different conditions and thread, please contact Walvoil Sales Dpt.



Innovation · Continuity · Integration
————— It is Power —————

 **walvoil**
FLUID POWER E| MOTION

 **walvoil**

 **hydro control**

 **Galtech**
IN POWER

D1WWEL01E
4th edition June 2019

Walvoil S.P.A. • 42124 Reggio Emilia • Italy • Via Adige, 13/D • Tel. +39.0522.932411 • Fax +39.0522.300984
www.walvoil.com

