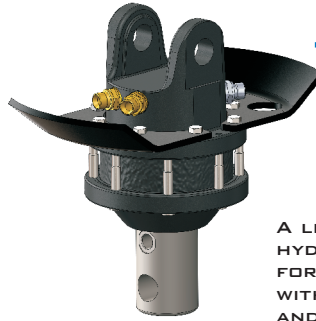
**FR 7 -SERIES**

ROTATION ANGLE	UNLIMITED
MAX WORKING PRESSURE	200 BAR
TORQUE	780 NM
MAX AXIAL FORCE	30 KN
SAFE WORKING LOAD	2000 KG
WEIGHT	16-22 KG

A LIGHT-WEIGHT AND EFFECTIVE HYDRAULIC ROTATOR WITH SEVERAL CONNECTION DIMENSIONS FOR CARGO CRANES AND AGRICULTURAL LOADERS. AVAILABLE WITH DIFFERENT SHAFT MODELS AND FLANGE MODELS.

**FR 21 -SERIES**

ROTATION ANGLE	UNLIMITED
MAX WORKING PRESSURE	200 BAR
TORQUE	1350 NM
MAX AXIAL FORCE	112 KN
SAFE WORKING LOAD	7500 KG
WEIGHT	39-45 KG

A LIGHT-WEIGHT AND EFFECTIVE HYDRAULIC ROTATOR FOR FOREST CRANES. AVAILABLE WITH DIFFERENT SHAFT MODELS AND FLANGE MODELS.

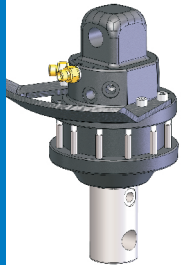
**FR 10 -SERIES**

ROTATION ANGLE	UNLIMITED
MAX WORKING PRESSURE	200 BAR
TORQUE	1000 NM
MAX AXIAL FORCE	60 KN
SAFE WORKING LOAD	4000 KG
WEIGHT	20-26 KG

A LIGHT-WEIGHT AND EFFECTIVE HYDRAULIC ROTATOR WITH SEVERAL CONNECTION DIMENSIONS FOR CARGO CRANES AND AGRICULTURAL LOADERS. AVAILABLE WITH DIFFERENT SHAFT MODELS AND FLANGE MODELS.

**FR 26 -SERIES**

ROTATION ANGLE	UNLIMITED
MAX WORKING PRESSURE	200 BAR
TORQUE	2200 NM
MAX AXIAL FORCE	120-150 KN
SAFE WORKING LOAD	6-10 TKG
WEIGHT	58-65 KG

A LIGHT-WEIGHT AND EFFECTIVE HYDRAULIC ROTATOR FOR FOREST CRANES AND EXCAVATOR. AVAILABLE WITH SHAFT MODELS AND FLANGE MODELS.

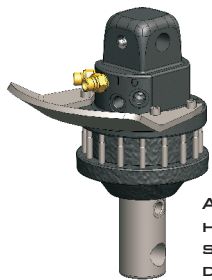
**FR 15 -SERIES**

ROTATION ANGLE	UNLIMITED
MAX WORKING PRESSURE	200 BAR
TORQUE	1150 NM
MAX AXIAL FORCE	82 KN
SAFE WORKING LOAD	5500 KG
WEIGHT	25-32 KG

A LIGHT-WEIGHT AND EFFECTIVE HYDRAULIC ROTATOR WITH SEVERAL CONNECTION DIMENSIONS FOR CARGO CRANES AND AGRICULTURAL LOADERS. AVAILABLE WITH DIFFERENT SHAFT MODELS AND FLANGE MODELS.

**FR M -SERIES**

ROTATION ANGLE	UNLIMITED
MAX WORKING PRESSURE	200 BAR
TORQUE	1150-2200 NM
MAX AXIAL FORCE	60-150 KN
SAFE WORKING LOAD	4-7,5 TKG
WEIGHT	25-50 KG

POWERFULL AND LIGHT-WEIGHT ROTATORS FOR HARVESTER HEADS.

FINN ROTOR

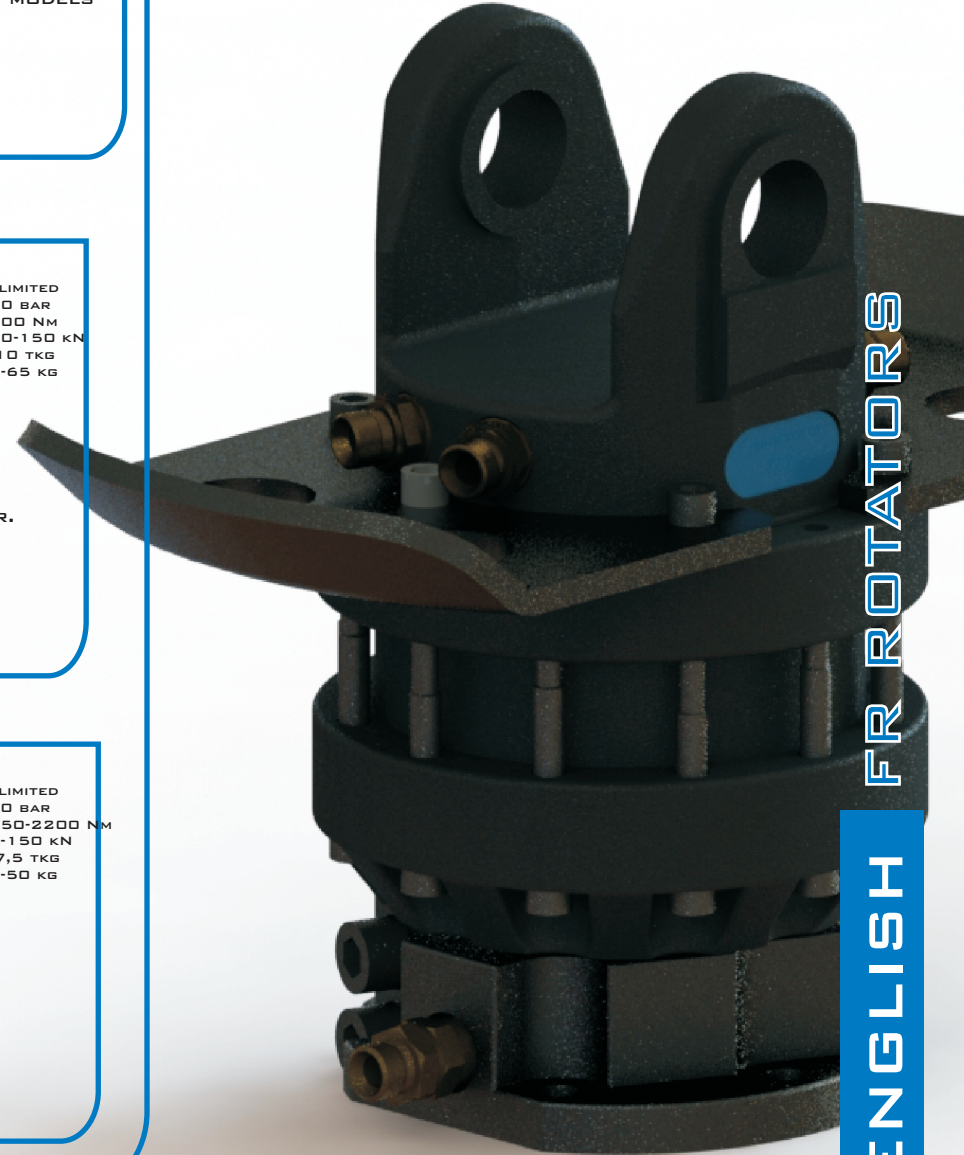

CR A ROTATORS



A LIGHT-WEIGHT AND EFFECTIVE HYDRAULIC ROTATORS WITH UNLIMITED ROTATION FOR DIFFERENT CUSTOMER VARIATIONS.

CHOOSE GENUINE **FINN ROTOR** ORIGINAL ACCESSORIES TO ENSURE SMOOTH WORKING. FROM THE WIDE VARIETY, YOU WILL FIND ALL NECESSARY ACCESSORIES. LINKS, BRAKELINKS, FLANGES AND HOUSINGS.

get Your crane moving!



EVERY FR -SERIES ROTATORS ARE AVAILABE WITH SEVERAL DIFFERENT UPPER COVER HOLE DIAMETERS AND SHAFT MACHINING.

MODIFICATIONS

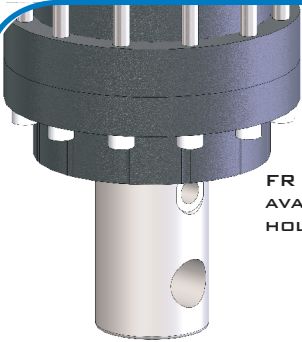

BR -ROTATOR INSIDE HOLDING BRAKE

FR -SERIES ROTATORS ARE AVAILABLE WITH INSIDE HOLDING BRAKE.

BR BRAKE

FLANGES

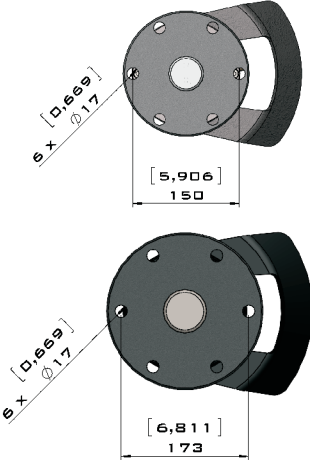

ALL FR -SERIES ROTATORS ARE AVAILABLE WITH DIFFERENT RANGE OF FLANGES.

M FLANGE

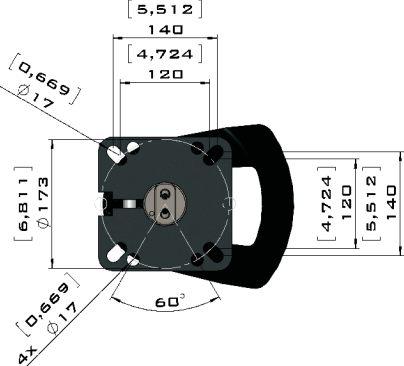

FR 7, FR 10 AND FR 15 -SERIES ROTATORS ARE AVAILABLE WITH MULTIFLANGES WHAT GIVAS ALL CONNECTION POSSIBILITIES.

ACCESSORIES



SD -DOUBLE BRAKING LINK

SD BOTH DIRECTION BRAKING LINK FOR PROFESSIONAL USE. AVAILABLE FOR EVERY BOOM HEAD DIMENSIONS AND FR ROTATORS.

ALSO WELDING BOOM HEAD IS AVAILABLE.

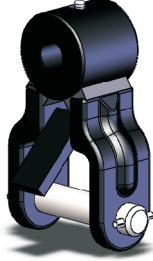

D -LINKS FOR FR -ROTATORS.

LH -LIFTING HOOKS

LH -LIFTING HOOKS AVAILABLE FOR FR -ROTATORS.

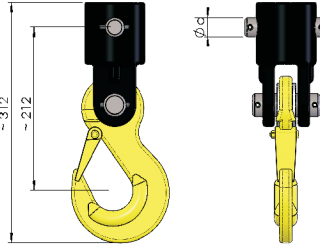

get Your crane moving!

WWW.FINN-ROTOR.COM
 INFO@FINN-ROTOR.COM
 +358 14 417 8400

PL 96,43101 SAARIJÄRVI
 FINLAND

CONTACT