

Diverter Valves

TECHNICAL CATALOGUE



Additional information

This catalogue shows the product in the most standard configurations.
Please contact our Sales Dpt. for more detailed information or special requests.

WARNING!

All specifications of this catalogue refer to the standard product at this date.
Walvoil, oriented to a continuous improvement, reserves the right to discontinue, modify or revise the specifications, without notice.

WALVOIL IS NOT RESPONSIBLE FOR ANY DAMAGE CAUSED BY AN INCORRECT USE OF THE PRODUCT.

1nd edition January 2020

MECHANICAL CONTROL MONOBLOCK DIVERTER VALVES

Type	Nr of ways	Type	Max. flow rating	Max. pressure	Page
			l/min (US gpm)	bar (psi)	
DF5	2 - 3 - 6	lever, cam, hydraulic, pneumatic	60 (15.9)	315 (4600)	5
DFC050	2 - 3 - 6	cam	60 (15.9)	315 (4600)	19
DF10	3 - 6	lever, cam, hydraulic, pneumatic	90 (23.5)	315 (4600)	25
DFC100	3 - 6	cam	90 (23.5)	315 (4600)	35
DF20	3 - 6	lever, cam, hydraulic, electrohydraulic, pneumatic	140 (37)	315 (4600)	41
DF25	3	lever, cam, hydraulic, electrohydraulic, pneumatic	280 (74)	315 (4600)	55
DF250	6	hydraulic	250 (66)	350 (5100)	67
DF350	6	hydraulic	350 (92.5)	350 (5100)	71

SOLENOID CONTROL DIVERTER VALVES

Type	Nr of ways	Type	Max. flow rating	Max. pressure		Supply voltage	Nominal power solenoid	Page
				without drain	with drain			
				l/min (US gpm)	bar (psi)			
DFE052	2 - 3 - 6 - 8	monoblock	60 (15.9)	200 (2900)	315 (4600)	12-14-24-48-98-110	38W	75
DFE10	3 - 6	monoblock	90 (23.5)	200 (2900)	315 (4600)	12-24-48-94-110-192	60W	87
DFE20	3 - 6	monoblock	140 (37)	200 (2900)	315 (4600)	12-20-24-94-192	60W	95
DFE085	4	monoblock for special applications	25 (6.6)	210 (3000)	-	12-14-24-48-98-110	38W	103
DFE110	12	monoblock for special applications	90 (23.5)	210 (3000)	315 (4600)	12-20-24-94-192	60W	109
DFE141	6 - 8	monoblock for special applications	80 (21)	250 (3600)	315 (4600)	12-20-24-94-192	60W	115
DFE080	6 - 8 - 10	sectional	25 (6.6)	210 (3000)	315 (4600)	12-14-24-48-98-110	38W	123
DFE100	6 - 8 - 10	sectional	50 (13)	210 (3000)	315 (4600)	12-14-24-48-98-110	38W	131
DFE140	6 - 8 - 10	sectional	80 (21)	210 (3000)	315 (4600)	12-20-24-94-192	60W	139

Diverter valves

ROTARY CONTROL DIVERTER VALVES					
Type	Nr of ways	Type	Max. flow rating	Max. pressure	Page
			l/min (US gpm)	bar (psi)	
DHZ5	3 - 4 - 6 - 8	mechanical rotary	60 (15.9)	315 (4600)	149
DHZ10	3 - 4 - 6 - 8	mechanical rotary	90 (23.5)	315 (4600)	149
DHZ20	3 - 4 - 6 - 8	mechanical rotary	140 (37)	315 (4600)	149
DH25	3 - 4 - 6 - 8	mechanical rotary	200 (52.8)	250 (3600)	149
DH30	3 - 6	mechanical rotary	280 (74)	210 (3000)	149
DDF3V-S	3	mechanical rotary	120 (31.7)	450 (6520)	155
RSAP2V	2	ball type valves	180 (47.5)	500 (7250)	157
RSAP3V	3	ball type valves	160 (42)	380 (5510)	157

Reference standards

		BSP	UN-UNF	NPTF	METRIC
THREAD ACCORDING TO		ISO 228/1	ISO 263	ANSI B1.20.3	ISO 262
		BS 2779	ANSI B1.1 unified		ISO 262
CAVITY ACCORDING TO	ISO	1179-1	11926-1		9974-1
	SAE		J1926-1	J476a	J2244
	DIN	3852-2 shape X or Y			3852-2 shape X or Y



DF5

Mechanical control monoblock diverter valves

- 2 - 3 - 6 ways configuration
- Mechanical lever, cam, hydraulic, pneumatic controls

This catalogue shows technical specifications and diagrams measured with mineral oil of 46 mm²/s (46 cSt) viscosity at 40°C - (104°F) temperature.

WORKING CONDITIONS		
N. of available ways		2 - 3 - 6
Max. flow rating		60 l/min (15.8 US gpm)
Max. pressure		315 bar (4600 psi)
Internal leakage A(B)⇒T	Δp=100 bar (1450 psi)	5 cm ³ /min (0.31 in ³ /min)
Fluid		Mineral based oil
Fluid temperature	with NBR (BUNA-N) seals	from -20°C to 80°C (from -4°F to 176°F)
	with FPM (VITON) seals	from -20°C to 100°C (from -4°F to 212°F)
Viscosity	operating range	from 15 to 75 mm ² /s (from 15 to 75 cSt)
	min.	12 mm ² /s (12 cSt)
	max.	400 mm ² /s (400 cSt)
Max. level of contamination		21/19/16 - ISO 4406 - NAS 1638 - class 10
Ambient temperature for working conditions	with mechanical controls	from -40°C to 60°C (from -40°F to 140°F)
	with hydraulic and pneumatic controls	from -30°C to 60°C (from -22°F to 140°F)

NOTE - For different working conditions please contact Sales Dept.

Available threads

PORTS THREAD				
ALL PORTS	BSP	UN-UNF	METRIC* (ISO 9974-1)	METRIC* (ISO 6149)
DF5	G 3/8	3/4-16 (SAE 8)	M18x1.5	M18x1.5
PILOT PORTS				
Pneumatic	NPT 1/8-27	NPT 1/8-27	NPT 1/8-27	NPT 1/8-27
Hydraulic	G 1/4	9/16-18 (SAE 6)	-	-

(*) Optional threads
for availability contact Sales
Department

Dimensional data - hydraulic circuit - performance data

2 ways

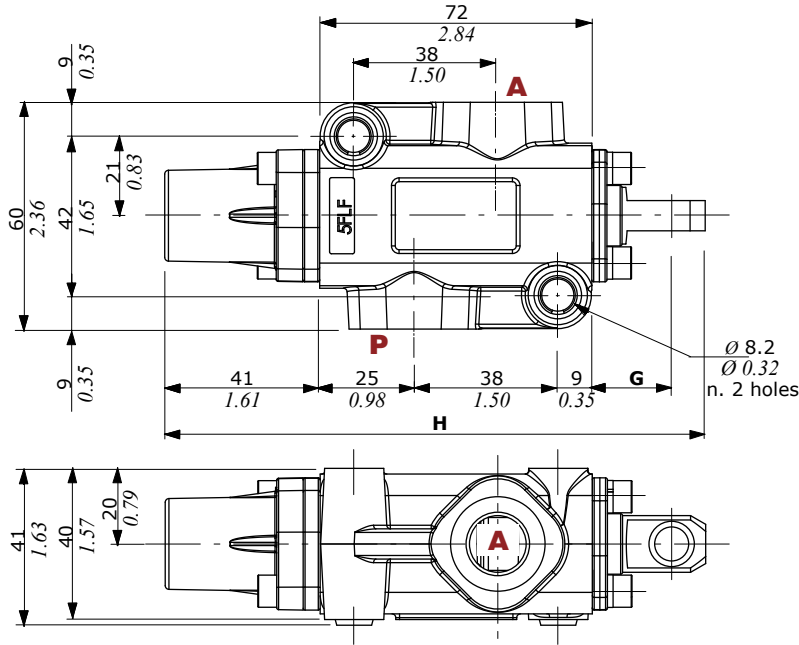

Pressure drop versus flow

P → A

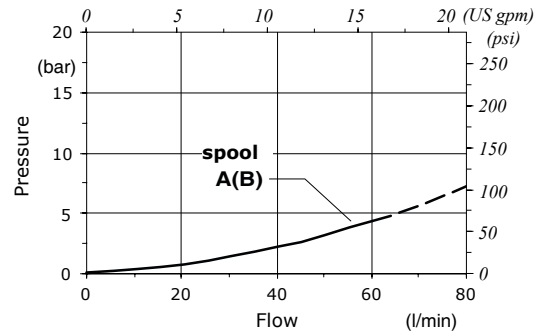

	G	H
With spool out	25.5 mm 1.00 in	147.5 mm 5.81 in
With spool in	14.5 mm 0.57 in	136.5 mm 5.37 in

3 ways

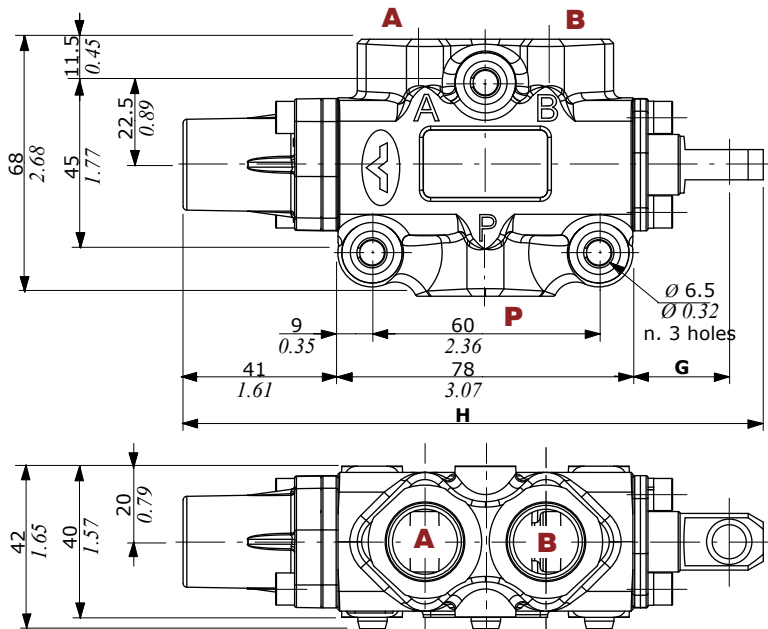

Pressure drop versus flow

P → A(B)

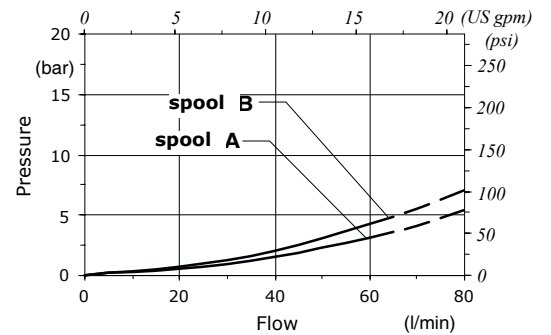

	G	H
With spool out	25.5 mm 1.00 in	153.5 mm 6.04 in
With spool in	14.5 mm 0.57 in	142.5 mm 5.60 in

Dimensional data - hydraulic circuit - performance data

6 ways

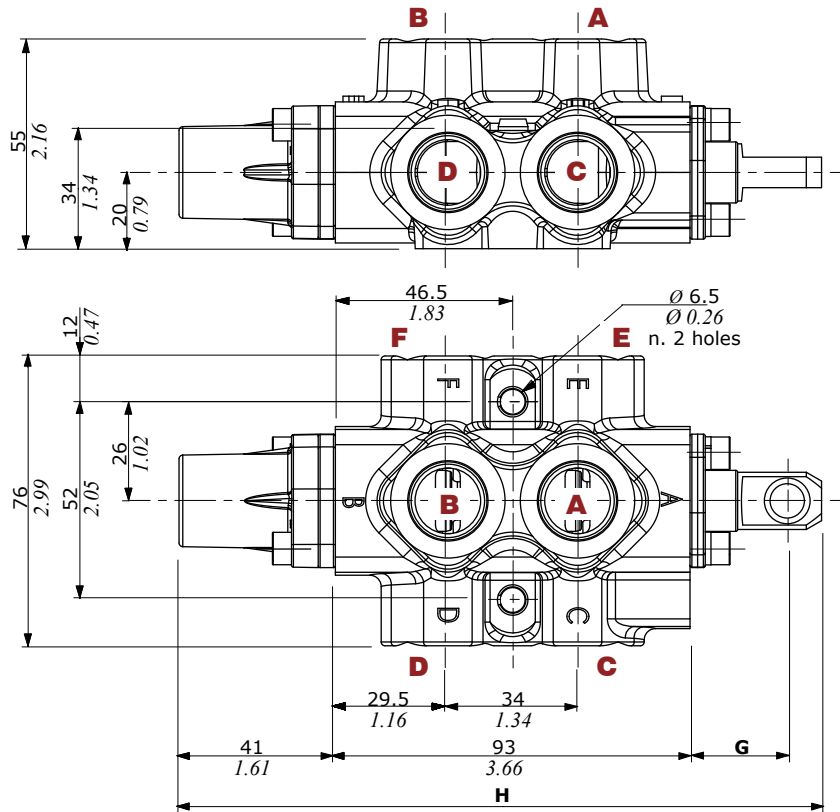

	G	H
With spool out	25.5 mm 1.00 in	168.5 mm 6.63 in
With spool in	14.5 mm 0.57 in	157.5 mm 6.20 in

Pressure drop versus flow

A → C(E)

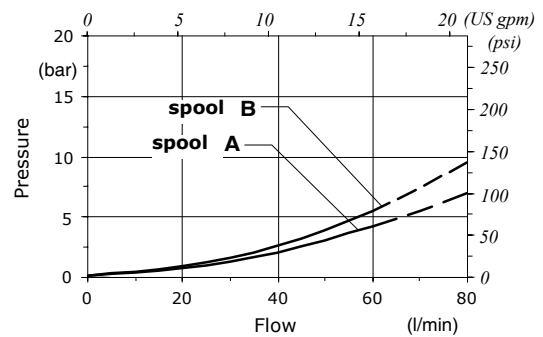
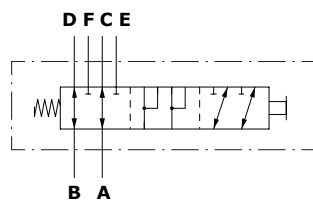

Part ordering codes

Example:

DF5/3 **A** **17** **SLP** - **SAE** - **(CVN)**
1 **2** **3** **4** **5** Painted with one layer of black Primer antirust

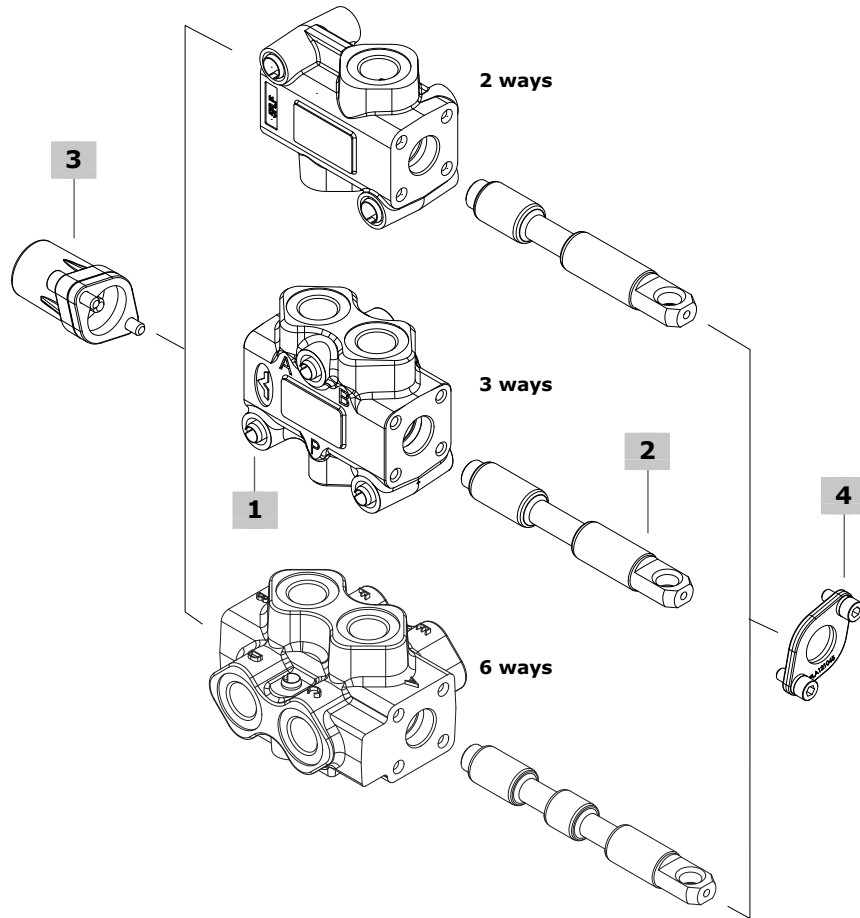

1 Body kit*

TYPE	CODE	DESCRIPTION
DF5/2	5CO2220700	2 ways body kit
DF5/3	5CO2221700	3 ways body kit
DF5/6	5CO2222700	6 ways body kit

2 Spools

page 10

TYPE	CODE	DESCRIPTION
for DF5/2:		
A	3CAS105210	Open port in neutral position
B	3CAS105110	Closed port in neutral position
AT	3CAS105230	As type A, with spherical end
BT	3CAS105130	As type B, with spherical end
AC	3CAS105220	As type A, for cam control
BC	3CAS105120	As type B, for cam control
V	3CAS105115	With load check valve
VT	3CAS105135	As type V, with spherical end
for DF5/3:		
A	3CAS105310	Flow in B in pos. 1. Ports connected in transit position
B	3CAS105410	Flow in B in pos. 1. Ports closed in transit position
AT	3CAS105330	As type A, with spherical end
AC	3CAS105320	As type A, for cam control
BC	3CAS105420	As type B, for cam control
D	3CAS105511	Flow in A and B in pos. 1. Without transit position: need 17A control type for reduced spool stroke
for DF5/6:		
A	3CAS105610	Flow in C and D. E and F closed in pos. 1. Ports connected in transit position
B	3CAS105710	Flow in C and D. E and F closed in pos. 1. Ports closed in transit position
AC	3CAS105620	As type A, for cam control
BC	3CAS105720	As type B, for cam control

3 "A" side spool positioners

page 11

TYPE	CODE	DESCRIPTION
12	5V12105000	Detent in positions 1 and 2
17	5V17105000	Spring return in position 1
17WPOA	5V17105002	As kit 17, waterproof type with plug for oil drain
17A	5V17105050	Spring return in pos. 1, it must be coupled to spool D (DF5/3)
17ME	5V17305000	As kit 17, with heavier spring type E
17MEWPO	5V17305002	As kit 17, with heavier spring type E waterproof type
17YME	5V17305003	As kit 17, with heavier spring type E
18ME	5V18405110	Spring return in pos. 2, with heavier spring type E

With microswitch

17MEMG2(NO)	5V17305680	Spring return in pos. 1, microswitch in pos. 2, with heavier spring type E
--------------------	------------	--

Pneumatic controls: must be coupled to the control kit side B with lever, with plate or cap

17PNB	5V17105718	On/off with spring return in position 1, waterproof type
18PNB	5V18105718	On/off with spring return in position 2, waterproof type

Hydraulic controls: must be coupled to the control kit side B with lever, with plate or cap

18IA1	5V18105850*	On/off high pressure hydraulic control with spring return in position 2
18IB1N	5V18105870*	On/off low pressure hydraulic control with spring return in position 2

4 "B" side options

page 16

TYPE	CODE	DESCRIPTION
SLP	5COP105000	Without lever box, with dust-proof plate kit
SLC	5COP205000	Without lever box, with cap
L	5LEV105000	Aluminum lever box
CA	5CAM105000	Steel ball bearing cam operation
CB	5CAM105020	Bronze cam operation
CAX/S5	5CAM105030	Inox steel cam operation
<u>Hydraulic controls</u>		
IA2	5IDR505700*	On/off with high pressure pilot, need 17YME control type
IB2	5IDR705700*	On/off with low pressure pilot, need 17YME control type

5 Body threadingSpecify threading always when it is different from **BSP** standard(*) - Codes are referred to **UN-UNF** thread

Spool end

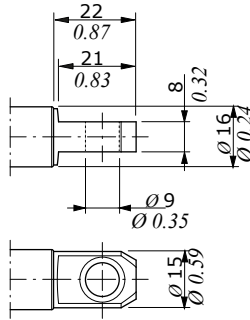

Standard:
spool type **A, B, D, V**

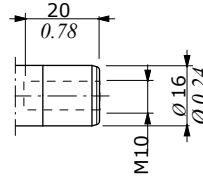

Rotary cam arrangement:
spool type **AC, BC**

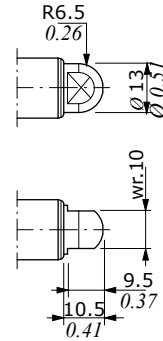

Spherical end:
spool type **AT, BT, VT**

Spool circuits

2 ways

Type A/AT/AC

Open port in neutral position

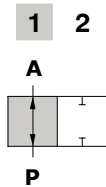

Spool stroke

Position 2: - 11 mm (- 0.43 in)

Type B/BT/BC

Closed port in neutral position

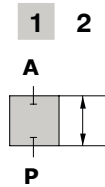

Spool stroke

Position 2: - 11 mm (- 0.43 in)

Type V/VT

With load check valve

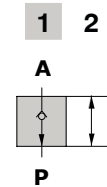

Spool stroke

Position 2: - 11 mm (- 0.43 in)

3 ways

Type A/AT/AC

Ports connected in transit position

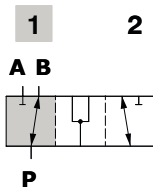

Spool stroke

Position 2: - 11 mm (- 0.43 in)

Type B/BC

Ports closed in transit position

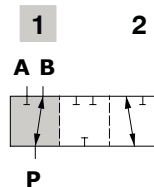

Spool stroke

Position 2: - 11 mm (- 0.43 in)

Type D

Without transit position
Ports connected in neutral

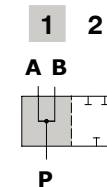

Spool stroke

Position 2: - 5.5 mm (- 0.21 in)

6 ways

Type A/AC

Flow in C and D. E and F closed in pos. 1
Ports connected in transit position

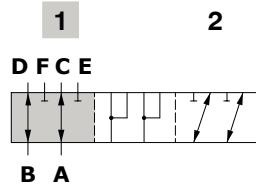

Spool stroke

Position 2: - 11 mm (- 0.43 in)

Type B/BC

Flow in C and D. E and F closed in pos. 1
Ports closed in transit position

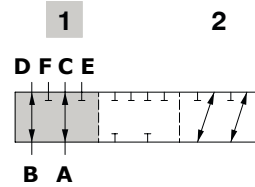

Spool stroke

Position 2: - 11 mm (- 0.43 in)

"A" side spool positioners

With detent

Type 12

Detent in positions 1 and 2

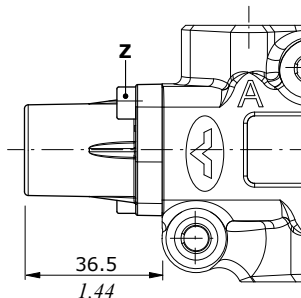

Wrenches and tightening torque

Z = wrench 4 - 6.6 Nm (4.9 lbf^t)

"A" side spool positioners

With spring return in position 1

Available with standard or heavier spring type "E"

Type 17-17ME-17YME

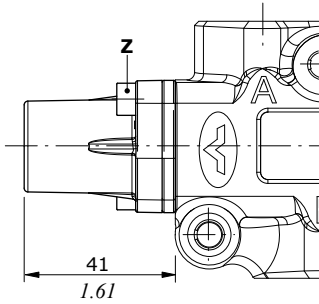

Wrenches and tightening torque
 Z = wrench 4 - 6.6 Nm (4.9 lbf_t)

Force-Stroke diagram

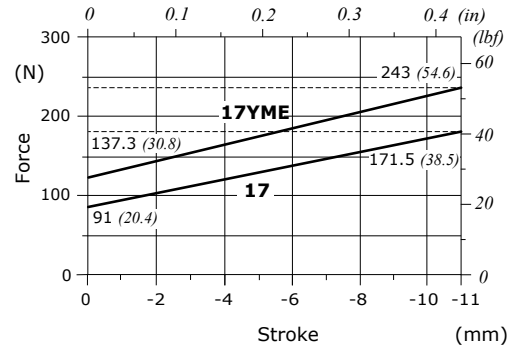

Type 17MEWPO

With water proof sealing

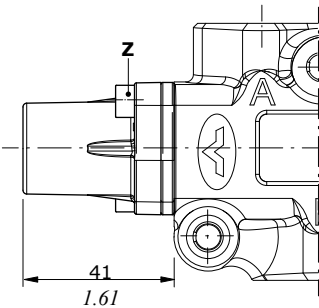

Type 17WPOA

With water proof sealing and plug for oil drain

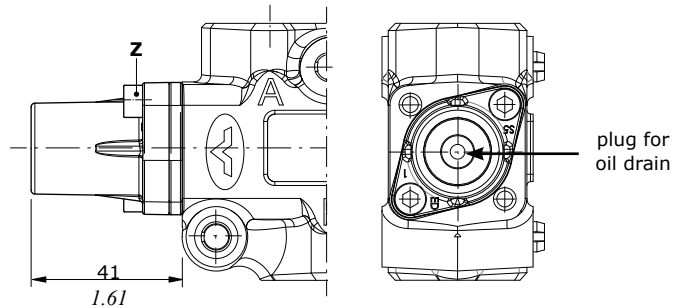

"A" side spool positioners

With spring return in position 1

Type 17A

As type 17, for spool type D

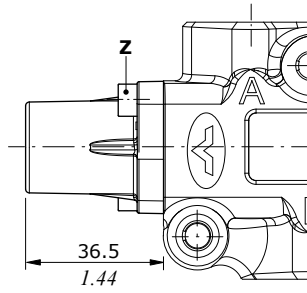

Wrenches and tightening torque
Z = wrench 4 - 6.6 Nm (4.9 lbf^t)

Force-Stroke diagram

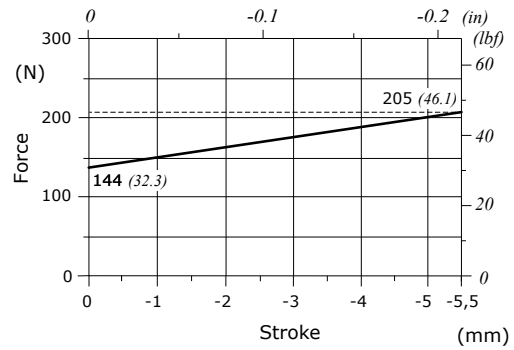

With spring return in position 2

With heavier spring type "E"

Type 18ME

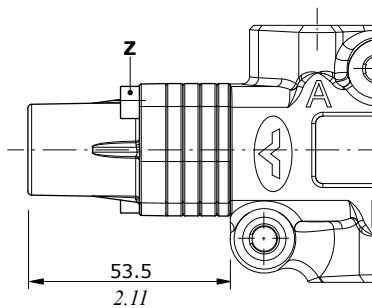
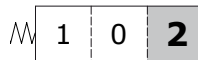

Wrenches and tightening torque
Z = wrench 4 - 6.6 Nm (4.9 lbf^t)

Force-Stroke diagram

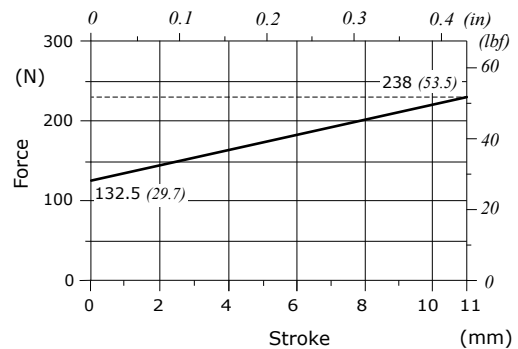

"A" side spool positioners

With spool position sensor

Type 17MEMG2(NO)

As type 17ME, with microswitch operated in pos. 1

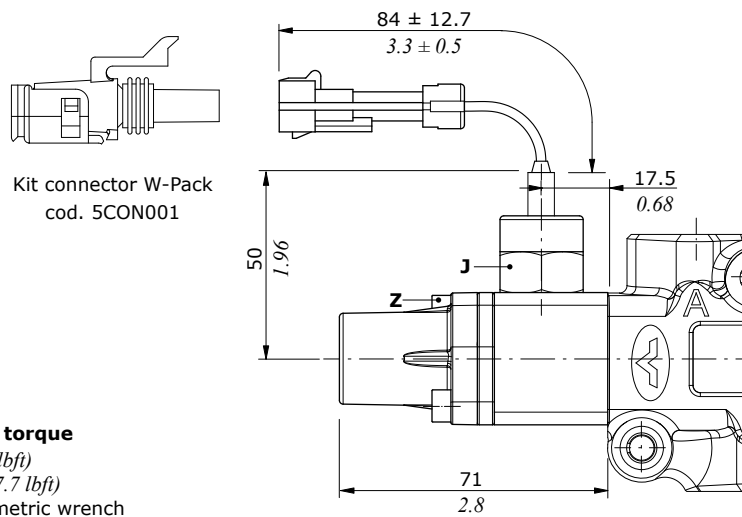
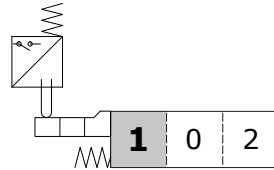

Wrenches and tightening torque

Z = wrench 4 - 6.6 Nm (4.9 lbft)

J* = wrench 22 - 24 Nm (17.7 lbft)

(*Tightening with dynamometric wrench

Complete controls			
Microswitch operation			
Circuit	pos. 1 17MG1	pos. 2 17MEMG2	pos. 2 17MG2
(NO)	5V17105673	5V17305680	-
(NC)	-	-	5V17105672

Force-Stroke diagram

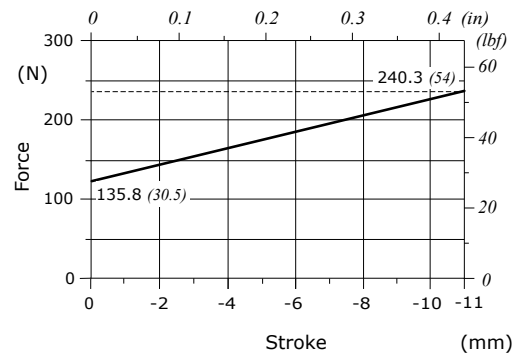

Features

MICROSWITCH

Mechanical life : 5x10⁵ operations

Electrical life (resistive load).... : 10⁵ oper. - 7A / 13.5VDC
 : 5x10⁴ oper. - 10A / 12VDC
 : 5x10⁴ oper. - 3A / 28VDC

Connector : Packard Weather-pack

Mating connector cod. 5CON001, not included

"A" side spool positioners

ON/OFF pneumatic controls

Type 17PNB

Spring return in pos. 1, waterproof type

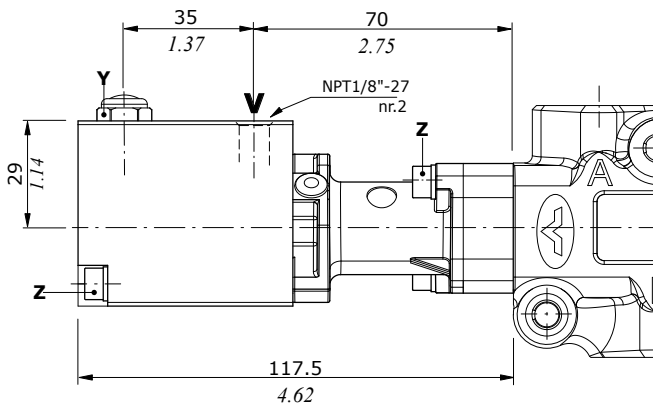
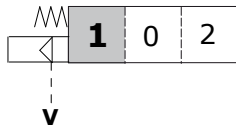

Type 18PNB

Spring return in pos. 2, waterproof type

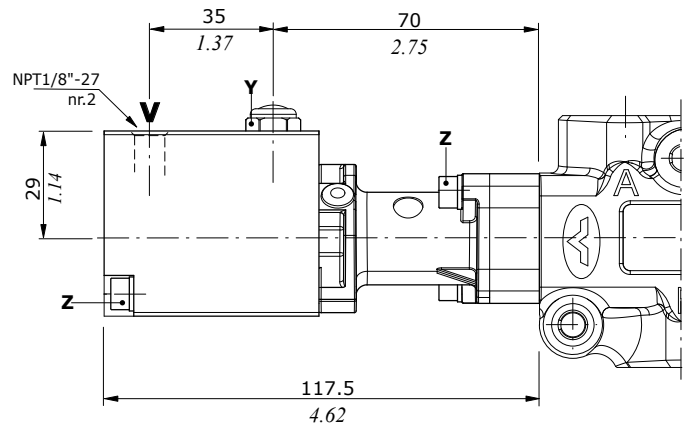
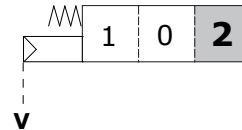

Wrenches and tightening torque

Z = wrench 4 - 6.6 Nm (4.9 lbft)
Y = wrench 13 - 9.8 Nm (7.2 lbft)

Hydraulic controls

Type 18IA1

High pressure hydraulic control with spring return in position 2

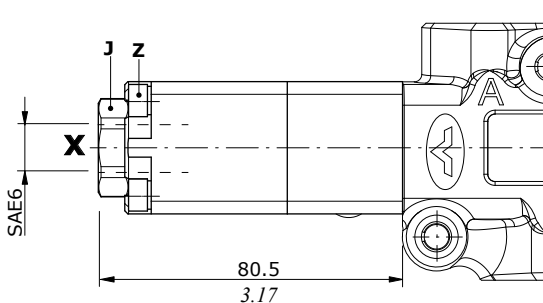
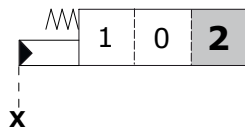

Pilot pressure... : min. 30 bar (435 psi) - max. 250 bar (3620 psi)

Type 18IB1N

Low pressure hydraulic control with spring return in position 2

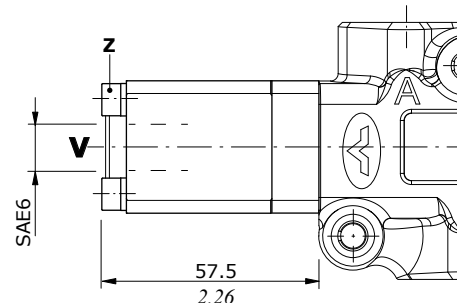
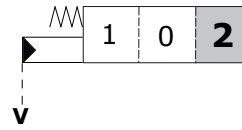

Pilot pressure... : min. 15 bar (217 psi) - max. 50 bar (725 psi)

Wrenches and tightening torque

Z = wrench 4 - 6.6 Nm (4.9 lbft)
J = wrench 24 - 42 Nm (31 lbft)

"B" side options

Lever control kit

Aluminium with protection boot lever pivot box; it can be rotated 180° (execution **L180**)

Type L

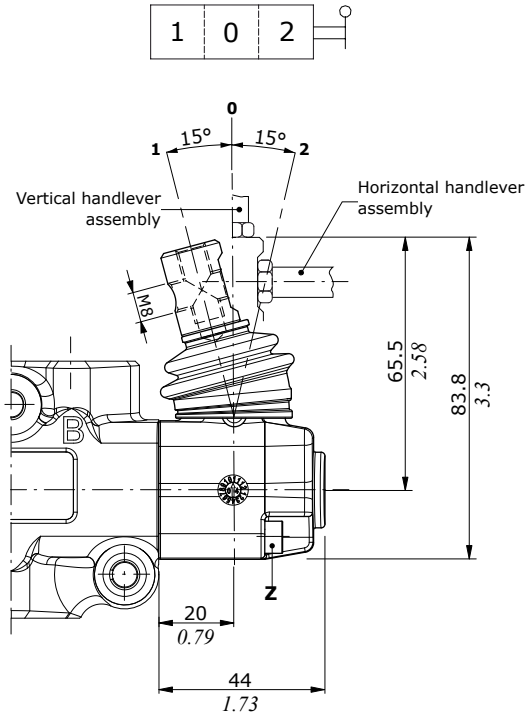

Cam control kit

Steel ball bearing cam operation (CA), and bronze cam operation (CB) or inox steel cam operation (CAX); it must be coupled to 17 control kit

Type CA-CB-CAX

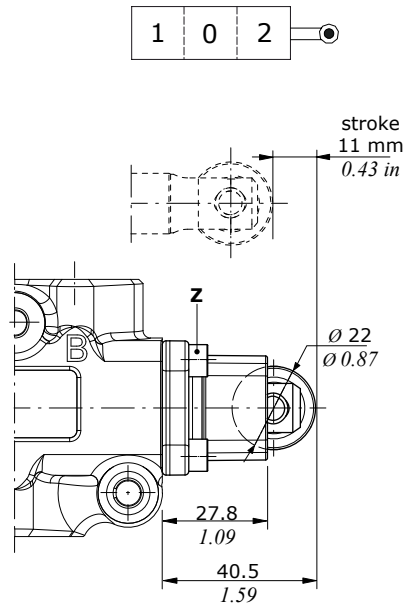

Wrenches and tightening torque

Z = wrench 4 - 6,6 Nm (4.9 lbft)

Without lever, with flange

Type SLP

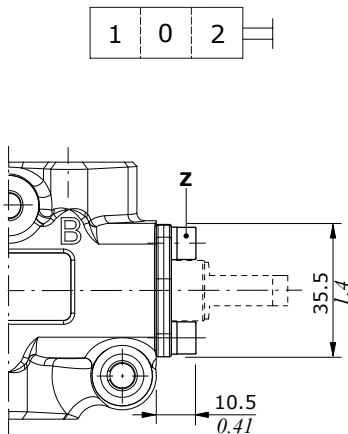

Wrenches and tightening torque

Z = wrench 4 - 6.6 Nm (4.9 lbft)

W = wrench 8 - 24 Nm (17.7 lbft)

Without lever, with cap

Protection cap to use with pneumatic and hydraulic spool positioner kits

Type SLC

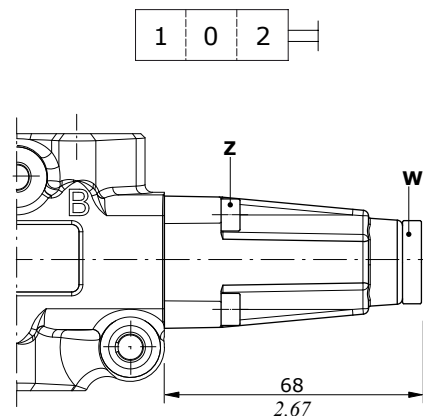

Hydraulic controls

ON/OFF controls with high and low pressure pilot it must be only coupled to 17YME control kit

Type IA2
High pressure pilot

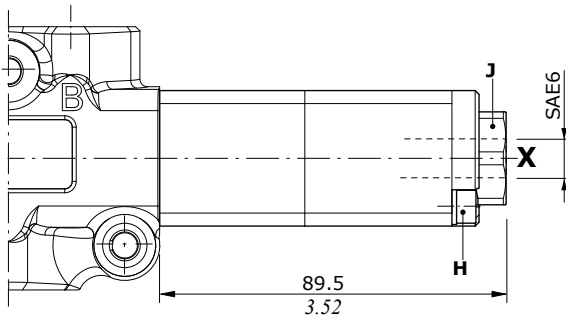
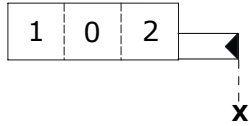

Pilot pressure... : min. 30 bar (435 psi) - max. 250 bar (3620 psi)

Type IB2
Low pressure pilot

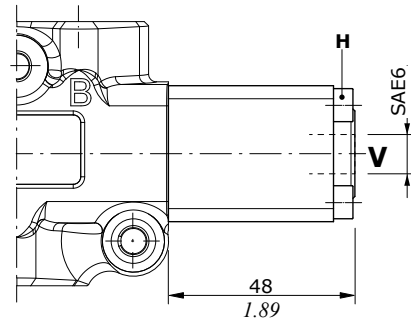
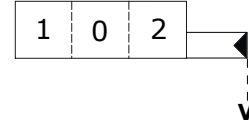

Pilot pressure... : min. 15 bar (217 psi) - max. 50 bar (725 psi)

Wrenches and tightening torque

H = wrench 5 - 9.8 Nm (7.2 lbf^t)

J = wrench 24 - 42 Nm (31 lbf^t)



DFC050

Mechanical control monoblock diverter valves

- 2 - 3 - 6 way configuration
- Cam controls
- Especially suitable for use in external environments

This catalogue shows technical specifications and diagrams measured with mineral oil of 46 mm²/s (46 cSt) viscosity at 40°C - (104°F) temperature.

WORKING CONDITIONS		
N. of available ways		2 - 3 - 6
Max. flow rating		60 l/min (15.8 US gpm)
Max. pressure		315 bar (4600 psi)
Internal leakage A(B)⇒T	Δp = 100 bar (1450 psi)	5 cm ³ /min (0.31 in ³ /min)
Fluid		Mineral based oil
Fluid temperature		from -20°C to 80°C (from -4°F to 176°F)
Viscosity	operating range	from 15 to 75 mm ² /s (from 15 to 75 cSt)
	min.	12 mm ² /s (12 cSt)
	max.	400 mm ² /s (400 cSt)
Max. level of contamination		21/19/16 - ISO 4406 - NAS 1638 - class 10
Ambient temperature for working conditions		from -40°C to 60°C (from -40°F to 140°F)

NOTE - For different working conditions please contact Sales Dept.

Available threads

PORTS THREAD				
ALL PORTS	BSP	UN-UNF	METRIC(*) (ISO 9974-1)	METRIC(*) (ISO 6149)
DFC050	G 3/8	3/4-16 (SAE 8)	M18x1.5	M18x1.5

(*) Optional threads
for availability contact Sales
Department

Dimensional data - hydraulic circuit - performance data

Cam spool control suggested for severe applications; it requires a special body, spool and control kit.

2 ways

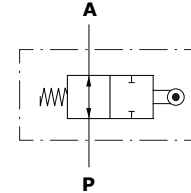
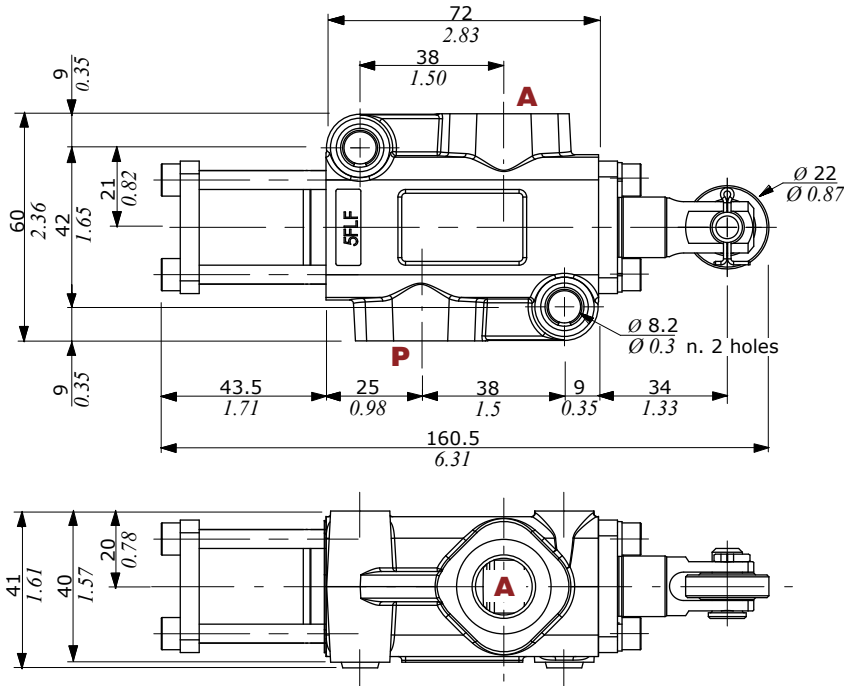

Pressure drop versus flow

P → A

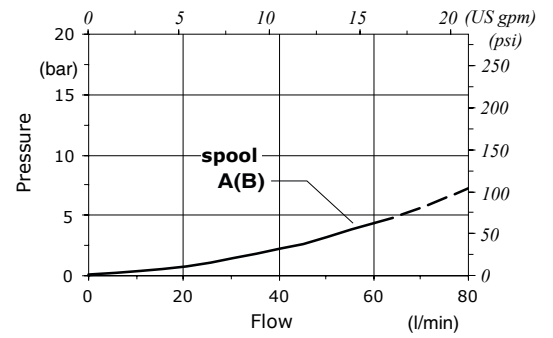

3 ways

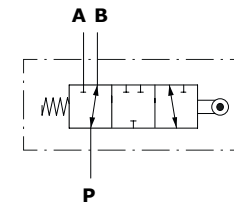
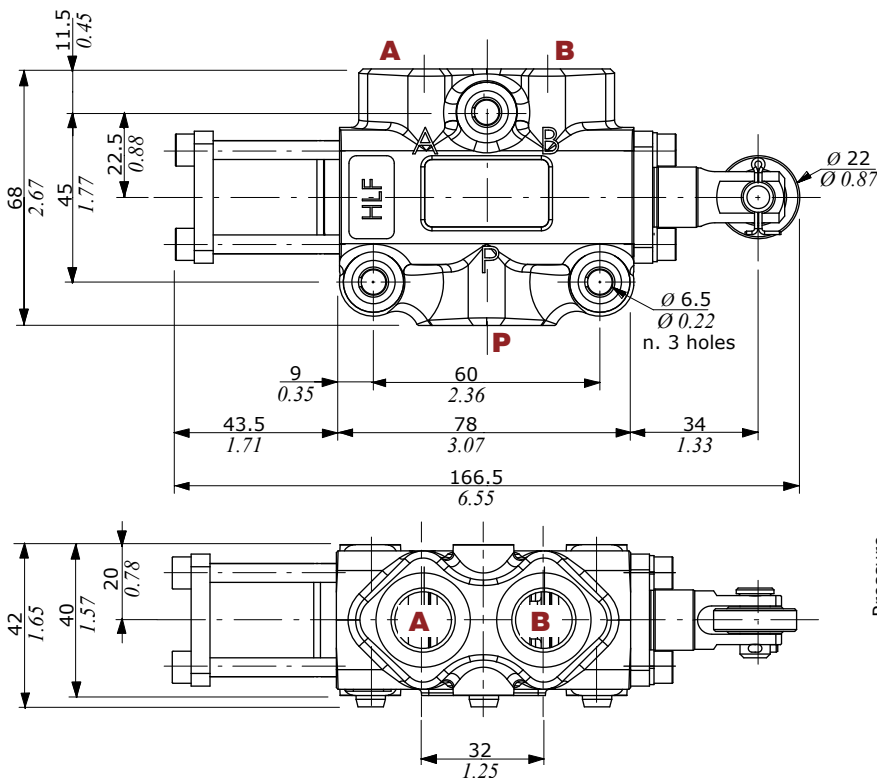

Pressure drop versus flow

P → A(B)

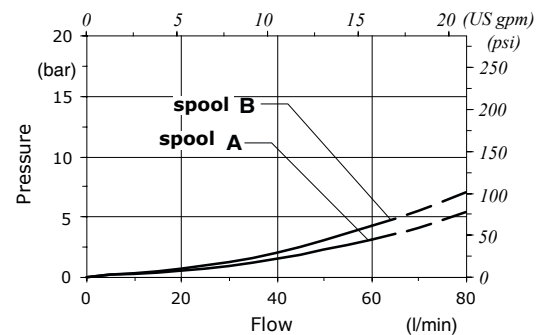

Dimensional data - hydraulic circuit - performance data

6 ways

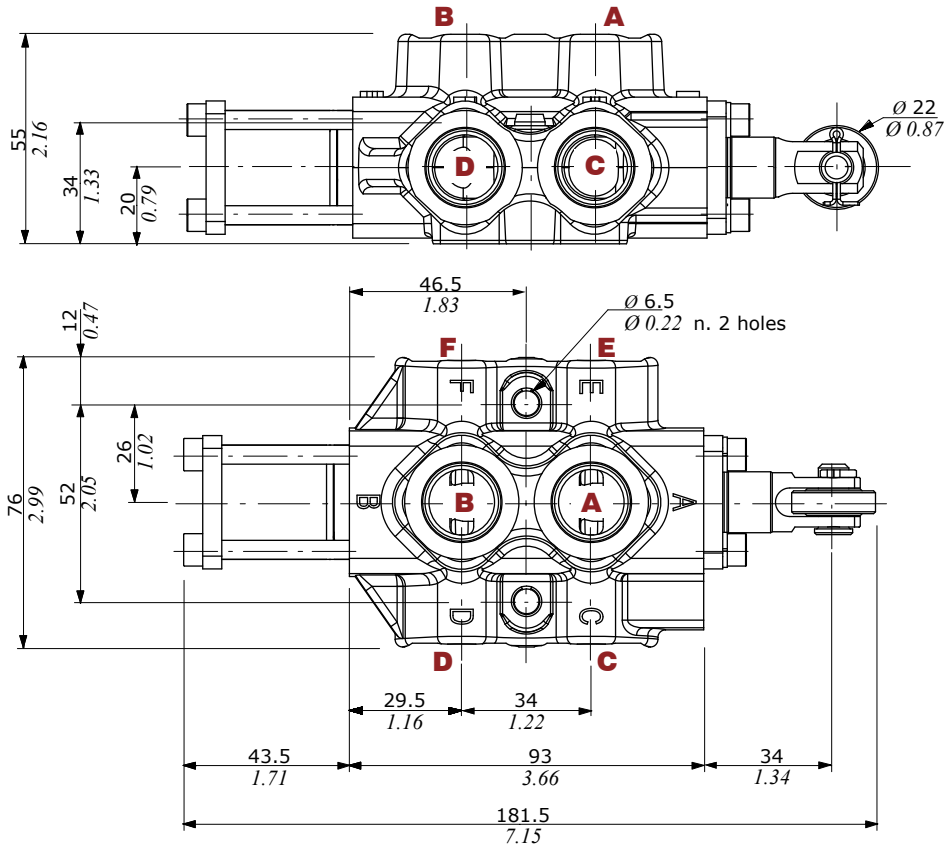

Pressure drop versus flow

A → C(E)

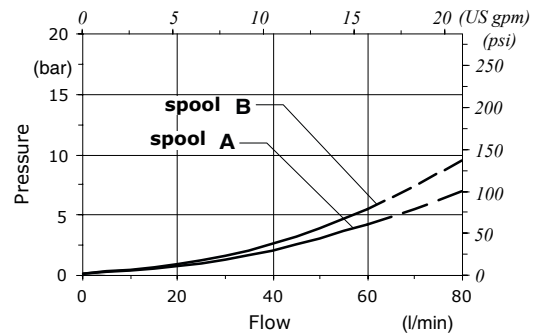
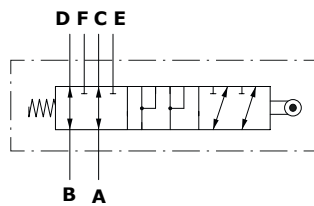

Part ordering codes

Example:

DFC050/3 **A** **17G** **SLP** - **SAE** - **(CVN)**

1
 2
 3
 4
 5

Painted with one layer of black Primer antirust

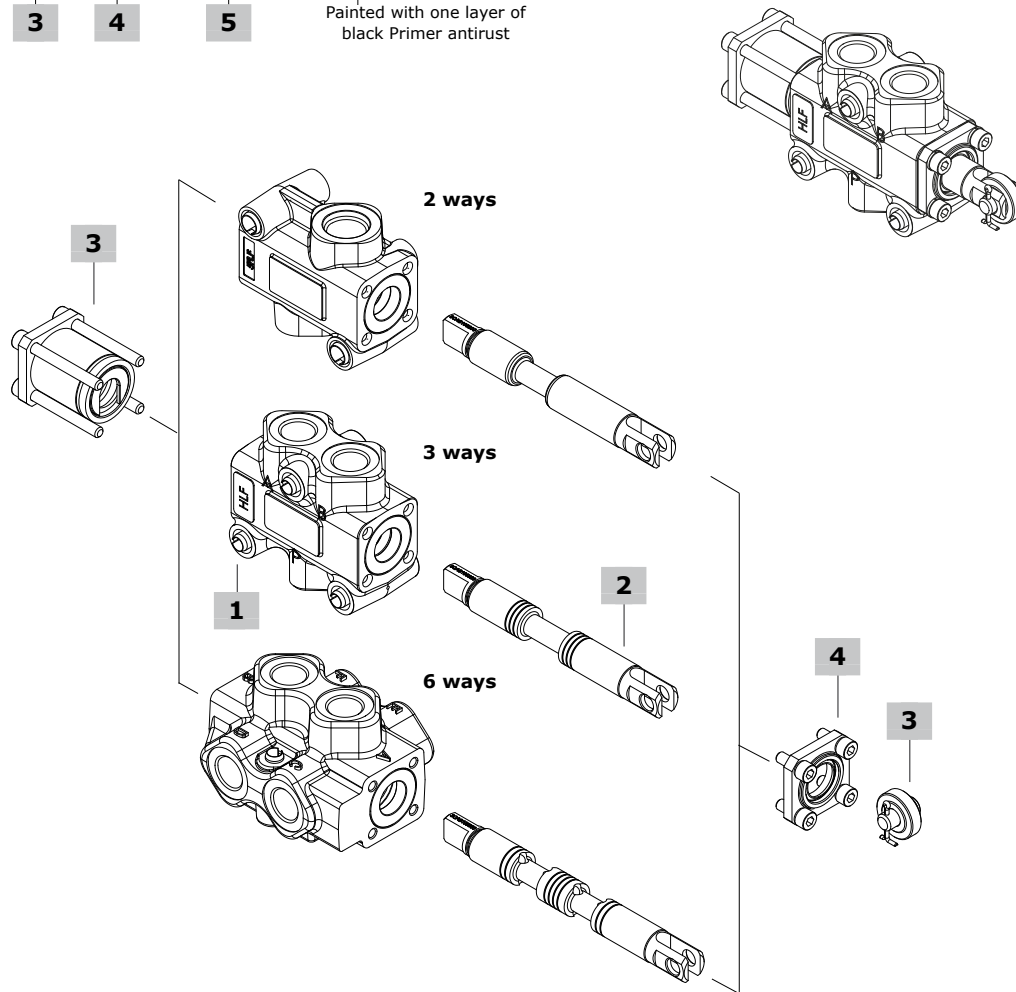

1 Body kit*

TYPE	CODE	DESCRIPTION
DFC050/2	5CO2220730	2 ways body kit
DFC050/3	5CO2221713	3 ways body kit
DFC050/6	5CO2222711	6 ways body kit

2 Spools page 23

TYPE	CODE	DESCRIPTION
for DFC050/2:		
A	3CAS105200	Open port in neutral position
B	3CAS105100	Closed port in neutral position
for DFC050/3:		
A	3CAS105323	Flow in B in pos. 1. Ports connected in transit position
B	3CAS105422	Flow in B in pos. 1. Ports closed in transit position
for DFC050/6:		
A	3CAS105660	Flow in C and D. E and F closed in pos. 1. Ports connected in transit position
B	3CAS105721	Flow in C and D. E and F closed in pos. 1. Ports closed in transit position

3 Complete controls page 24

TYPE	CODE	DESCRIPTION
17G	5V17905000	Cam control with spring return in pos. 1
17GCAX	5V17905001	Inox steel cam control with spring return in pos. 1

4 "B" side options page 24

TYPE	CODE	DESCRIPTION
SLP	5COP107000	with dust-proof plate

5 Body threading

Specify threading always when it is different from **BSP** standard

(*) - Codes are referred to **UN-UNF** thread

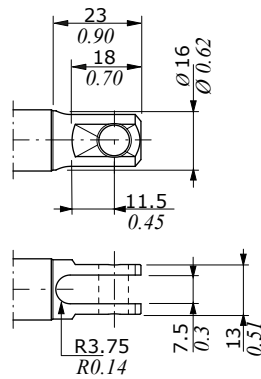

Rotary cam arrangement:
spool type **A, B**

2 ways

Type A

Open port in neutral position

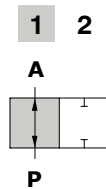

Spool stroke

Position 2: - 11 mm (- 0.43 in)

Type B

Closed port in neutral position

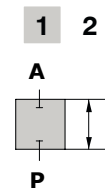

Spool stroke

Position 2: - 11 mm (- 0.43 in)

3 ways

Type A

Ports connected
in transit position

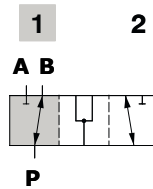

Spool stroke

Position 2: - 11 mm (- 0.43 in)

Type B

Ports closed
in transit position

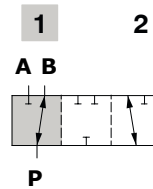

Spool stroke

Position 2: - 11 mm (- 0.43 in)

6 ways

Type A

Flow in C and D. E and F closed in pos. 1
Ports connected in transit position

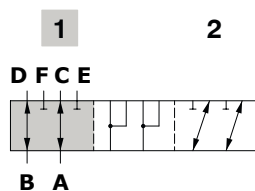

Spool stroke

Position 2: - 11 mm (- 0.43 in)

Type B

Flow in C and D. E and F closed in pos. 1
Ports closed in transit position

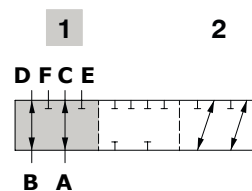

Spool stroke

Position 2: - 11 mm (- 0.43 in)

Complete controls

Cam control kit

17G type cam control available with stainless steel bearing (type 17GCAX).
It must be coupled with type SLP flange on valve B side

Type 17G - 17GCAX
Spring return in position 1

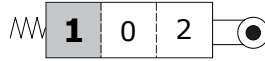

Wrenches and tightening torque
Z = wrench 4 - 6.6 Nm (4.9 lbf)

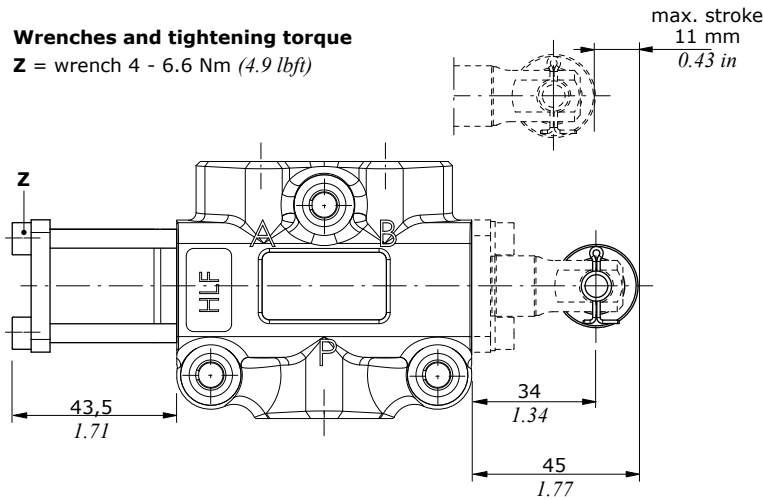

Force-Stroke diagram

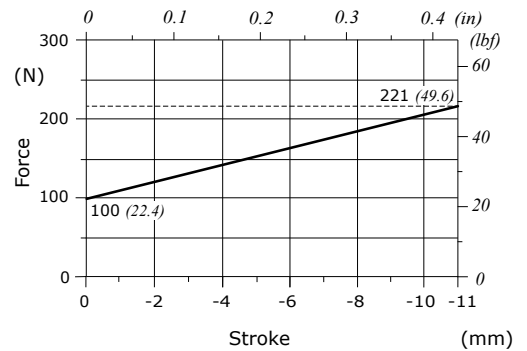

"B" side options

Without lever, with flange

Type SLP

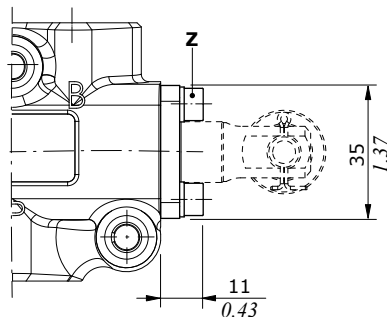
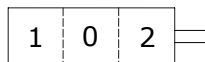

Wrenches and tightening torque
Z = wrench 4 - 6.6 Nm (4.9 lbf)



DF10

Mechanical control monoblock diverter valves

- 3 - 6 ways configuration
- Mechanical lever, cam, hydraulic, pneumatic controls

This catalogue shows technical specifications and diagrams measured with mineral oil of 46 mm²/s (46 cSt) viscosity at 40°C (104°F) temperature.

WORKING CONDITIONS

N. of available ways	3 - 6	
Max. flow rating	90 l/min (23.7 US gpm)	
Max. pressure	315 bar (4600 psi)	
Internal leakage A(B)⇒T	$\Delta p = 100 \text{ bar (1450 psi)}$	5 cm ³ /min (0.31 in ³ /min)
Fluid	Mineral based oil	
Fluid temperature	with NBR (BUNA-N) seals	from -20°C to 80°C (from -4°F to 176°F)
	with FPM (VITON) seals	from -20°C to 100°C (from -4°F to 212°F)
Viscosity	operating range	from 15 to 75 mm ² /s (from 15 to 75 cSt)
	min.	12 mm ² /s (12 cSt)
	max.	400 mm ² /s (400 cSt)
Max. level of contamination	21/19/16 - ISO 4406 - NAS 1638 - class 10	
Ambient temperature for working conditions	with mechanical controls	from -40°C to 60°C (from -40°F to 140°F)
	with hydraulic and pneumatic controls	from -30°C to 60°C (from -22°F to 140°F)

NOTE - For different working conditions please contact Sales Dept.

Available threads

PORTS THREAD			
ALL PORTS	BSP	UN-UNF	METRIC* (ISO 9974-1)
DF10	G 1/2	7/8-14 (SAE 10)	M22x1.5
BOCCHIE PILOTAGGI			
Pneumatic	NPT 1/8-27	NPT 1/8-27	NPT 1/8-27
Hydraulic	G 1/4	9/16-18 (SAE 6)	-

(*) Optional threads
for availability contact Sales
Department

Dimensional data - hydraulic circuit - performance data

3 ways

It's possible to obtain 2 ways diverter valve plugging port

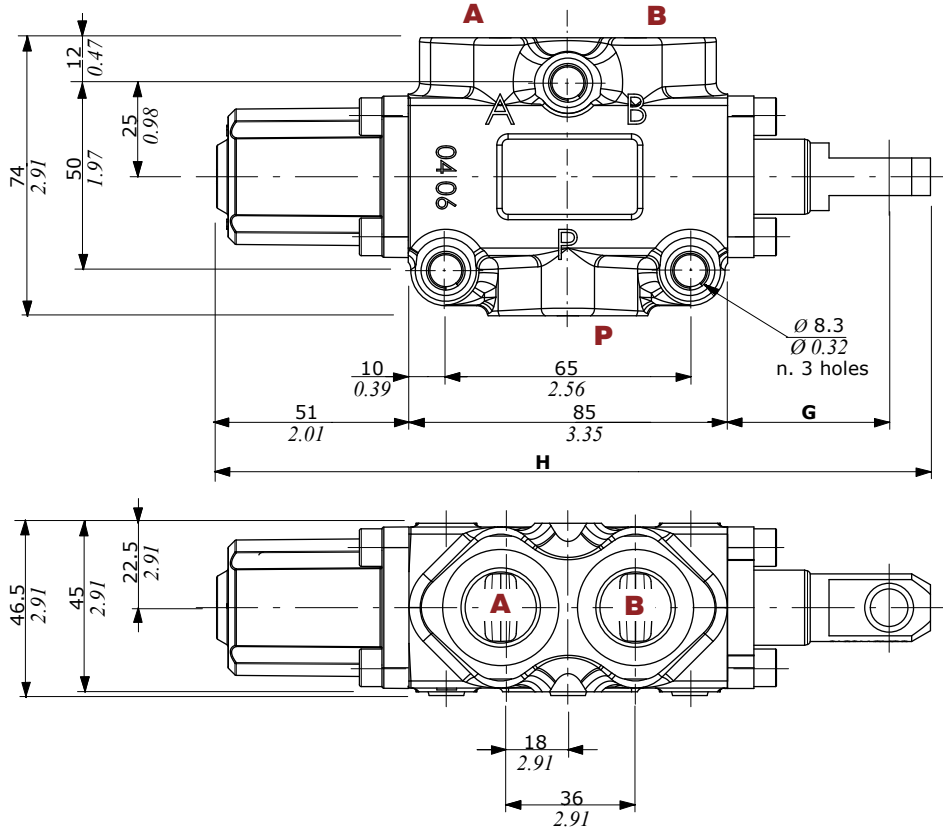

	G	H
With spool out	43 mm 1.69 in	190 mm 7.48 in
With spool in	29 mm 1.14 in	176 mm 6.92 in

Pressure drop versus flow

P → A(B)

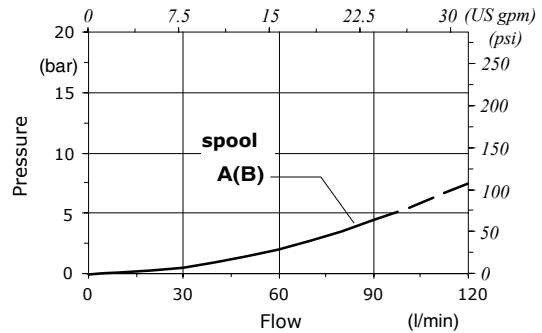
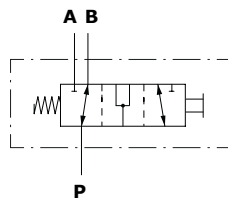

Dimensional data - hydraulic circuit - performance data

6 ways

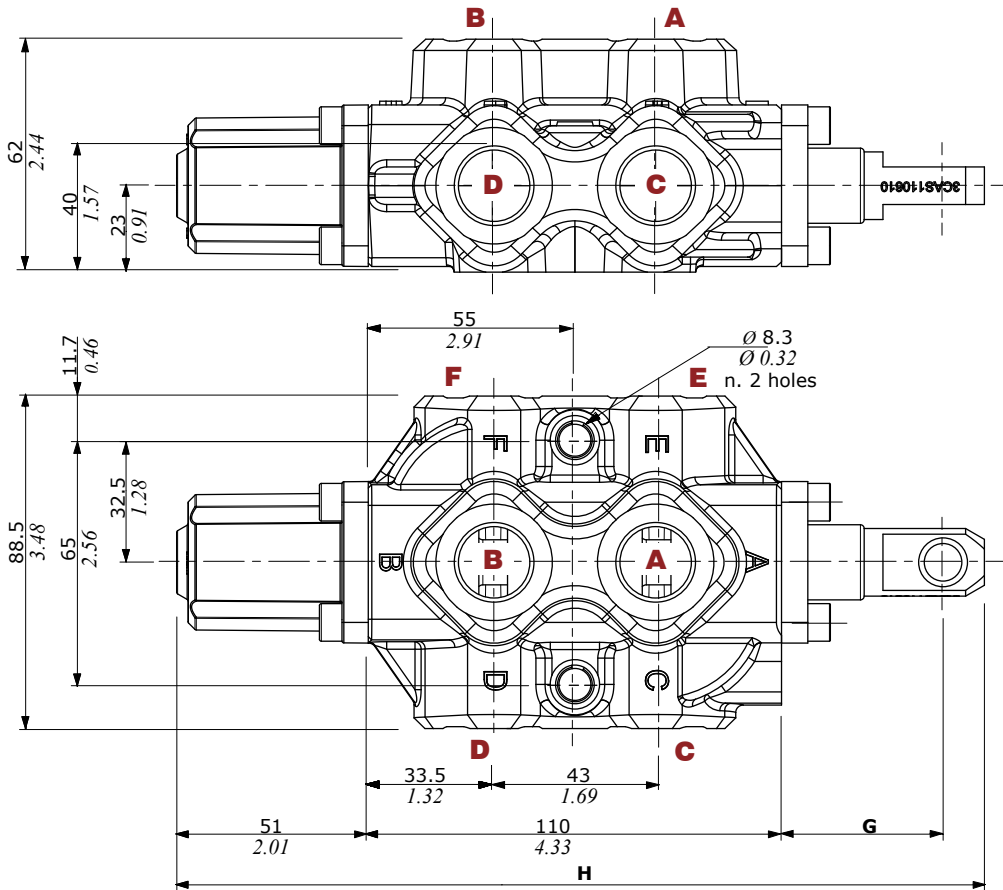

	G	H
With spool out	43 mm 1.69 in	215 mm 8.46 in
With spool in	29 mm 1.14 in	201 mm 7.91 in

Pressure drop versus flow

A → C(E)

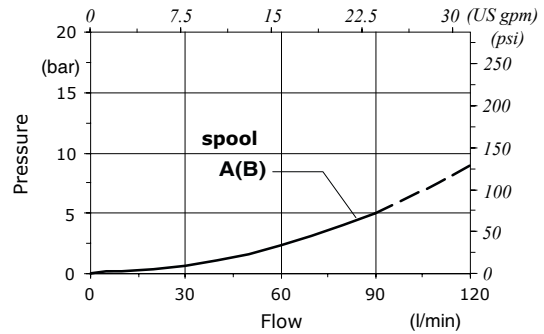
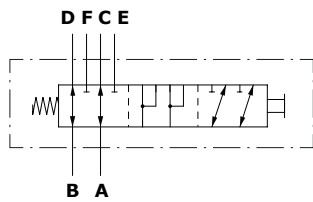

Part ordering codes

Example:

DF10/3 **A** **17** **SLP** - **SAE** - **(CVN)**

1

2

3

4

5

Painted with one layer of black Primer antirust

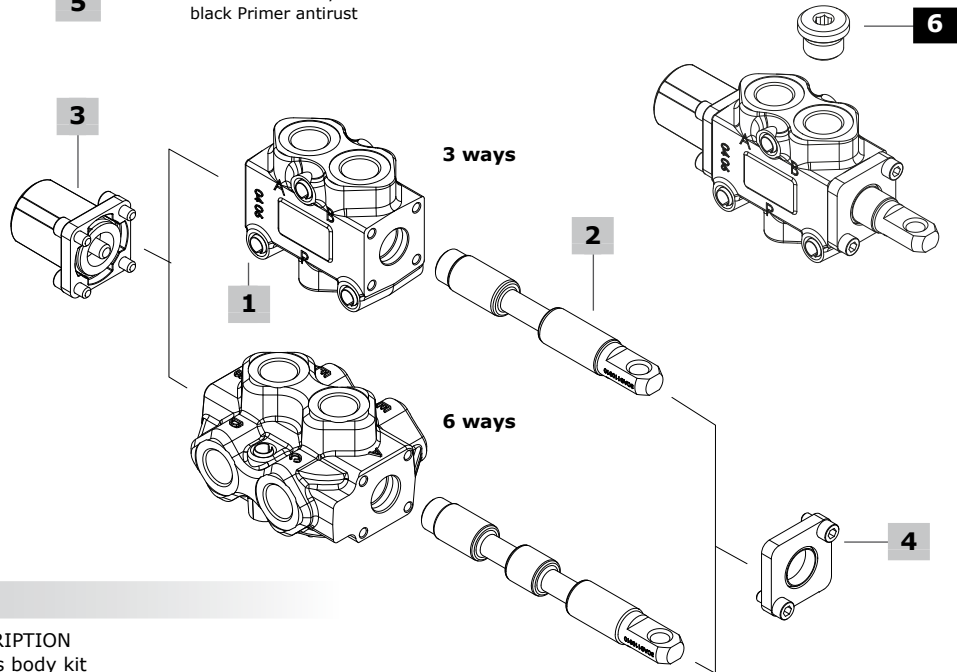

1 Body kit*

TYPE	CODE	DESCRIPTION
DF10/3	5CO2241700	3 ways body kit
DF10/6	5CO2242700	6 ways body kit

2 Spools

page 29

TYPE	CODE	DESCRIPTION
for DF10/3:		
A	3CAS110310	Flow in B in pos. 1. Ports connected in transit position
B	3CAS110410	Flow in B in pos. 1. Ports closed in transit position
AT	3CAS110330	As type A, with spherical end
AC	3CAS110320	As type A, for cam control
BC	3CAS110420	As type B, for cam control
DC	3CAS110520	Flow in A, B in pos. 1. Without transit position, for cam control

for DF10/6:

A	3CAS110610	Flow in C and D. E and F closed in pos. 1. Ports connected in transit position
B	3CAS110710	Flow in C and D. E and F closed in pos. 1. Ports closed in transit position
AC	3CAS110620	As type A, for cam control
BC	3CAS110720	As type B, for cam control

3 "A" side spool positioners

page 30

TYPE	CODE	DESCRIPTION
12	5V12110000	Detent in positions 1 and 2
17	5V17110000	Spring return in position 1
17ME	5V17310000	As kit 17, with heavier spring type E
18	5V18110000	Spring return in position 2
<u>Pneumatic controls: must be coupled to the control kit side B with lever, with plate or cap</u>		
17P	5V17110700	On/off, with spring return in pos. 1
18P	5V18110710	On/off, with spring return in pos. 2
<u>Hydraulic controls: must be coupled to the control kit side B with lever, with plate or cap</u>		
18IA1	5V18110850*	On/off high pressure hydraulic kit with spring return in position 2
18IB1	5V18110870*	On/off low pressure hydraulic kit with spring return in position 2

4 "B" side options

page 33

TYPE	CODE	DESCRIPTION
SLP	5COP110000	Without lever box, with dust-proof plate kit
SLC	5COP210000	Without lever box, with cap
L	5LEV110000	Aluminum lever box
CA	5CAM110000	Steel ball bearing cam operation
CB	5CAM110020	Bronze cam operation
<u>Hydraulic controls</u>		
IA2	5IDR510701*	On/off with high pressure pilot, need 17ME control type
IB2	5IDR710700*	On/off with low pressure pilot, need 17ME control type

5 Body threading

Specify threading always when it is different from **BSP** standard

6 Port plugs*

CODE	DESCRIPTION
3XTAP826160	SAE10 plug

It's possible to obtain 2 ways diverter valve plugging DF10/3 port

(*) - Codes are referred to **UN-UNF** thread

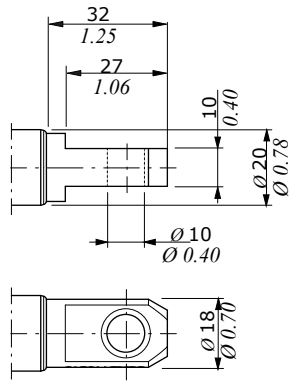

Standard:
spool type **A, B**

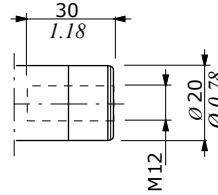

Rotary cam arrangement:
spool type **AC, BC, DC**

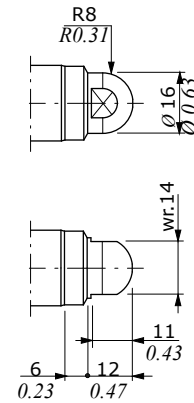

Spherical end:
spool type **AT**

Spool circuits

3 ways

Type A/AT/AC

Ports connected
in transit position

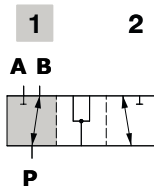

Spool stroke

Position 2: - 14 mm (- 0.55 in)

Type B/BC

Ports closed
in transit position

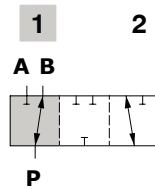

Spool stroke

Position 2: - 14 mm (- 0.55 in)

Type DC

Without transit position
Ports connected in neutral

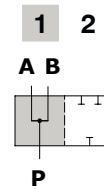

Spool stroke

Position 2: - 14 mm (- 0.55 in)

6 ways

Type A/AC

Flow in C and D. E and F closed in pos. 1
Ports connected in transit position

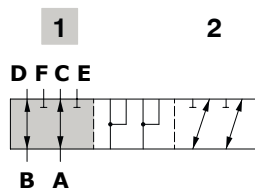

Spool stroke

Position 2: - 14 mm (- 0.55 in)

Type B/BC

Flow in C and D. E and F closed in pos. 1
Ports closed in transit position

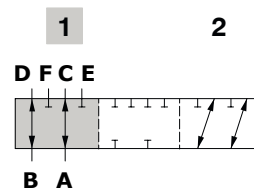

Spool stroke

Position 2: - 14 mm (- 0.55 in)

"A" side spool positioners

With detent

Type 12

Detent in positions 1 and 2

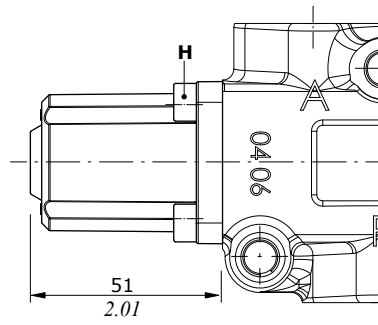

Wrenches and tightening torque

H = wrench 5 - 9.8 Nm (7.2 lbf)

With spring return in position 1

With heavier spring type "E"

Type 17

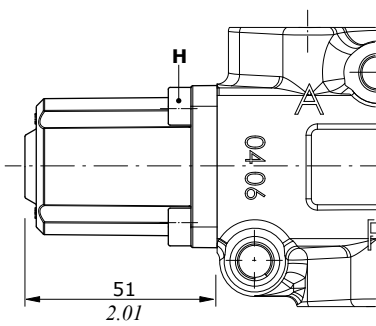

Type 17ME

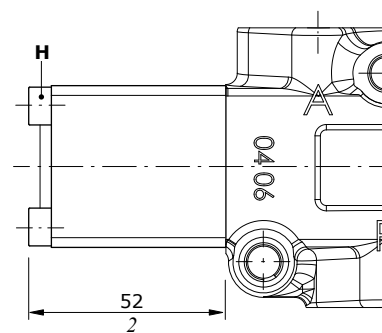

Wrenches and tightening torque

H = wrench 5 - 9.8 Nm (7.2 lbf)

Force-Stroke diagram

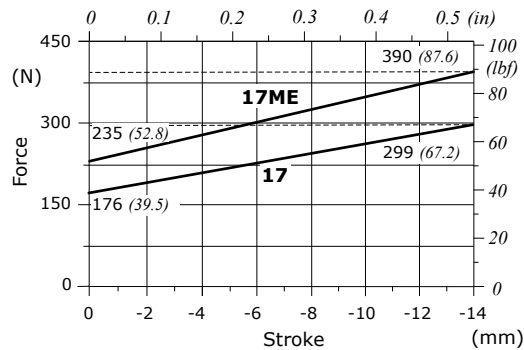

"A" side spool positioners

With spring return in position 2

Type 18

Wrenches and tightening torque

H = wrench 5 - 9.8 Nm (7.2 lbf_t)

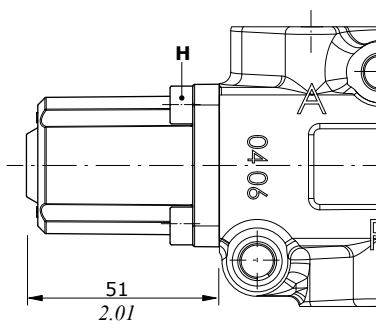
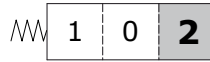

Force-Stroke diagram

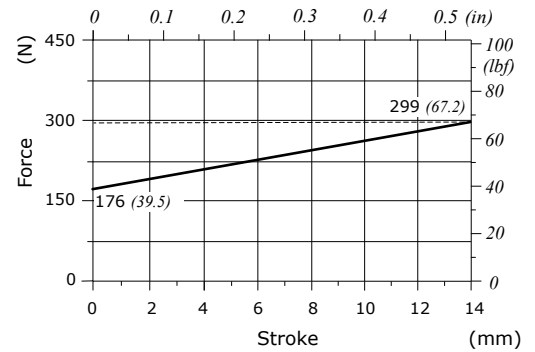

ON/OFF pneumatic controls

Type 17P

Spring return in pos. 1

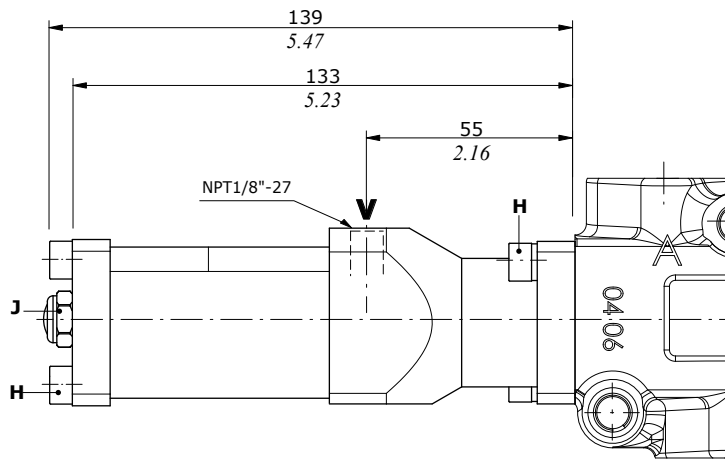
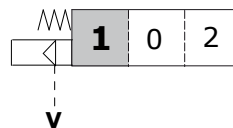

Wrenches and tightening torque

H = wrench 5 - 9.8 Nm (7.2 lbf_t)

J = wrench 13 - 9.8 Nm (7.2 lbf_t)

Pilot pressure... : min. 7 bar (101 psi) - max. 10 bar (145 psi)

"A" side spool positioners

ON/OFF pneumatic controls

Type 18P

Spring return in pos. 2

Wrenches and tightening torque

H = wrench 5 - 9.8 Nm (7.2 lbf_t)

J = wrench 13 - 9.8 Nm (7.2 lbf_t)

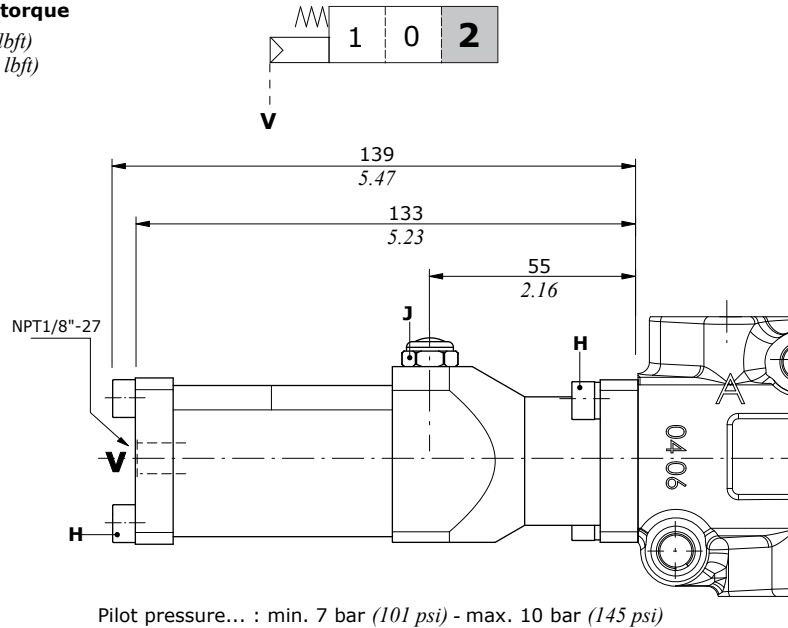

Hydraulic controls

Type 18IA1

High pressure hydraulic kit with spring return in position 2

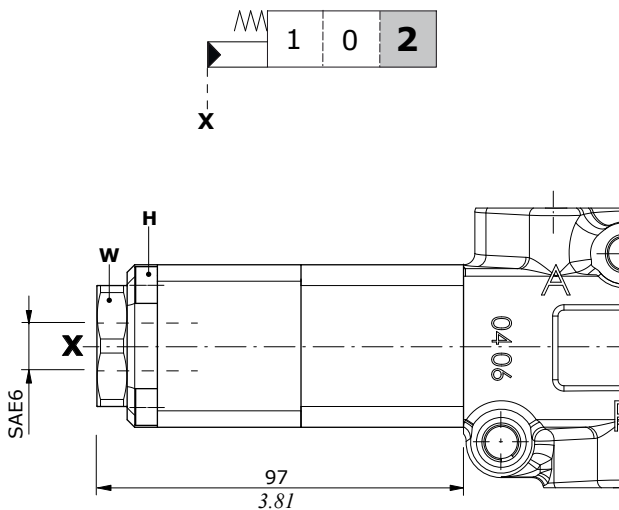

Pilot pressure... : min. 30 bar (435 psi) - max. 250 bar (3620 psi)

Type 18IB1

Low pressure hydraulic kit with spring return in position 2

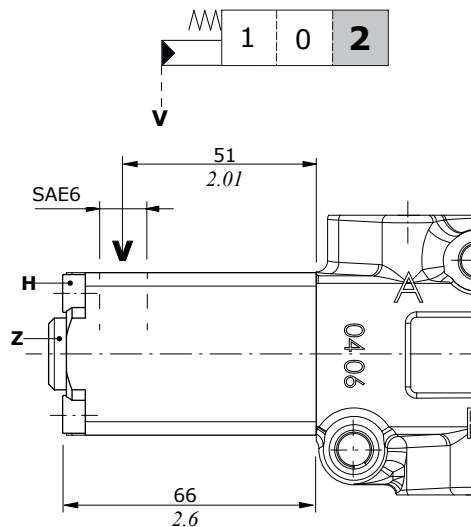

Pilot pressure... : min. 15 bar (217 psi) - max. 50 bar (725 psi)

Wrenches and tightening torque

H = wrench 5 - 9.8 Nm (7.2 lbf_t)

Z = wrench 6 - 24 Nm (17.7 lbf_t)

W = wrench 32 - 42 Nm (31 lbf_t)

"B" side options

Lever control kit

Aluminium with protection boot lever pivot box; it can be rotated 180° (execution **L180**)

Type L

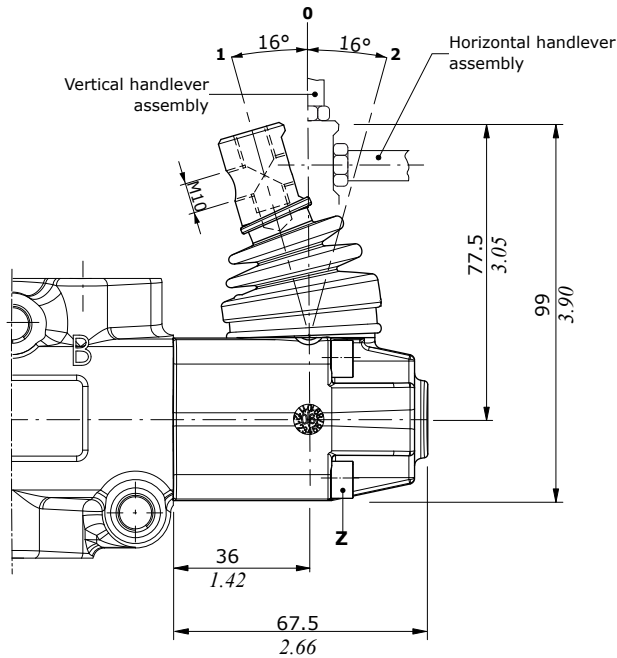
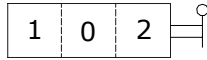

Cam control kit

Steel ball bearing cam operation (CA), and bronze cam operation (CB); it must be coupled to 17 control kit

Type CA-CB

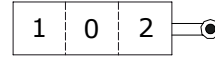

Wrenches and tightening torque

Z = wrench 5 - 9.8 Nm (7.2 lbf)

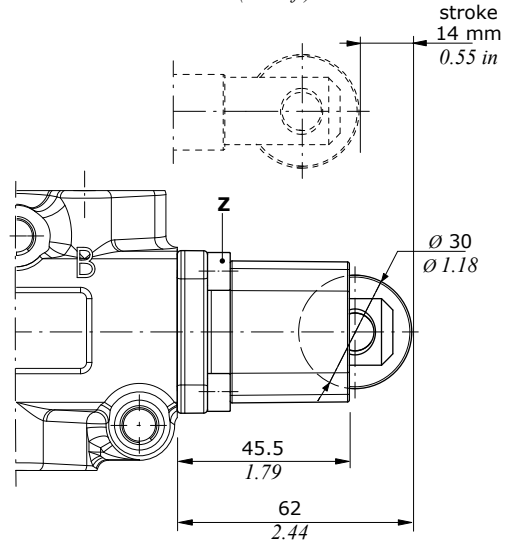

Without lever, with flange

Type SLP

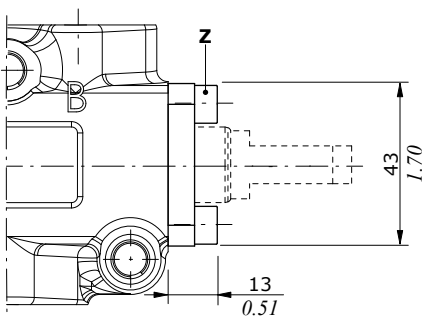
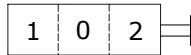

Wrenches and tightening torque

Z = wrench 5 - 9.8 Nm (7.2 lbf)

W = wrench 8 - 24 Nm (17.7 lbf)

Without lever, with cap

Protection cap to use with pneumatic and hydraulic spool positioner kits

Type SLC

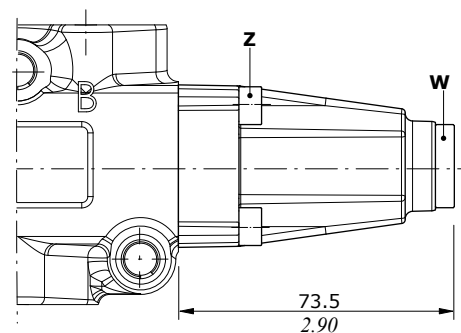
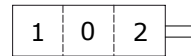

"B" side options

Hydraulic controls

ON/OFF controls with high and low pressure pilot it must be only coupled to 17ME control kit

Type IA2
High pressure pilot

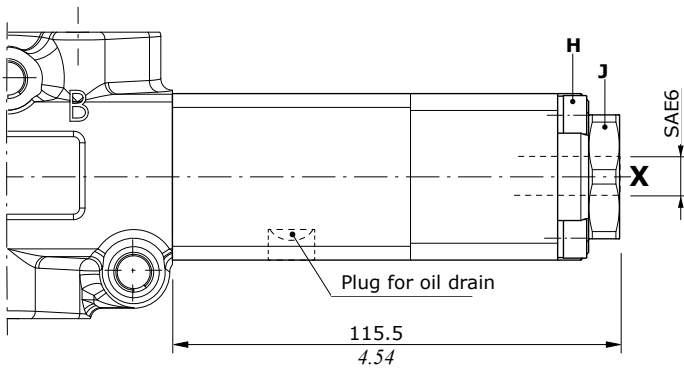
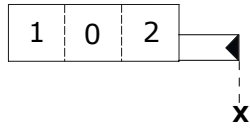

Pilot pressure... : min. 30 bar (435 psi) - max. 250 bar (3620 psi)

Type IB2
Low pressure pilot

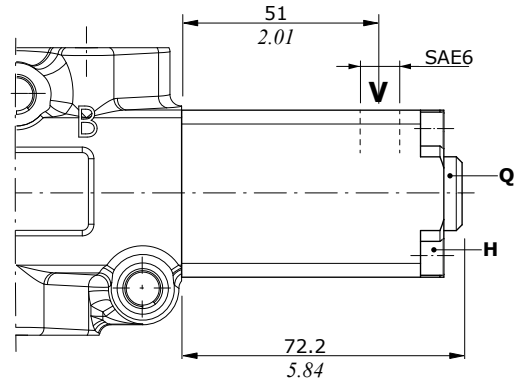
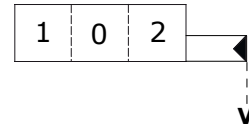

Pilot pressure... : min. 15 bar (217 psi) - max. 50 bar (725 psi)

Wrenches and tightening torque

H = wrench 5 - 9.8 Nm (7.2 lbft)

J = wrench 24 - 42 Nm (31 lbft)

Q = wrench 6 - 24 Nm (17.7 lbft)



DFC100

Mechanical control monoblock diverter valves

- 3 - 6 ways configuration
- Cam control kit
- Especially suitable for use in external environments

This catalogue shows technical specifications and diagrams measured with mineral oil of 46 mm²/s - 46 cSt viscosity at 40°C - 104°F temperature.

WORKING CONDITIONS

N. of available ways	3 - 6	
Max. flow rating	90 l/min (23.7 US gpm)	
Max. pressure	315 bar (4600 psi)	
Internal leakage A(B)⇒T	Δp = 100 bar (1450 psi)	5 cm ³ /min (0.31 in ³ /min)
Fluid	Mineral based oil	
Fluid temperature	from -20°C to 80°C (from -4°F to 176°F)	
Viscosity	operating range	from 15 to 75 mm ² /s (from 15 to 75 cSt)
	min.	12 mm ² /s (12 cSt)
	max.	400 mm ² /s (400 cSt)
Max. level of contamination	21/19/16 - ISO 4406 - NAS 1638 - class 10	
Ambient temperature for working conditions	from -40°C to 60°C (from -40°F to 140°F)	

NOTE - For different working conditions please contact Sales Dept.

Available threads

PORTS THREAD

ALL PORTS	BSP	UN-UNF	METRIC* (ISO 9974-1)
DFC100	G 1/2	7/8-14 (SAE 10)	M22x1.5

(*) Optional threads
for availability contact Sales
Department

Dimensional data - hydraulic circuit - performance data

Cam spool control suggested for severe applications; it requires a special body, spool and control kit.

3 way

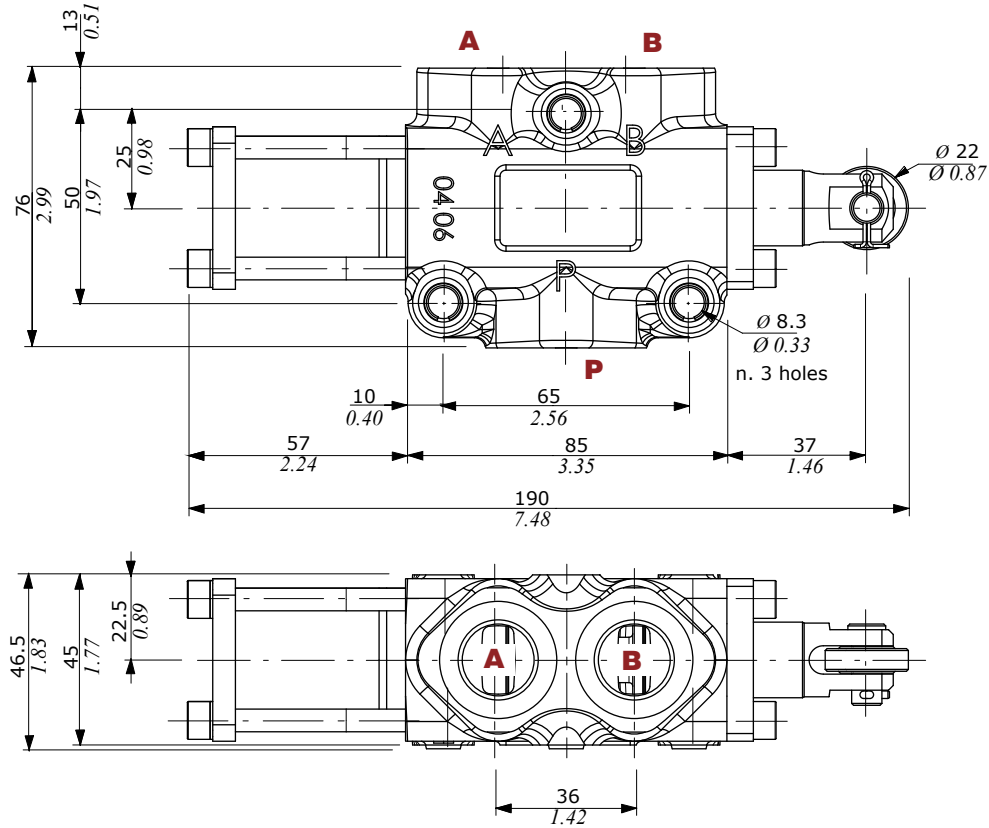

Pressure drop versus flow

P → A(B)

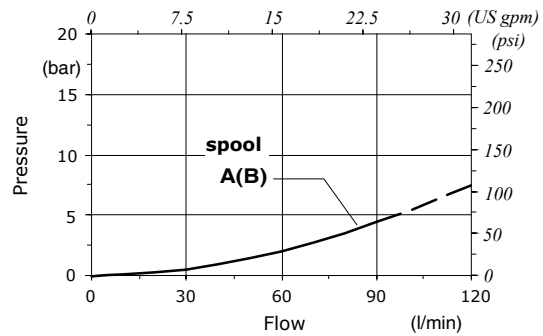
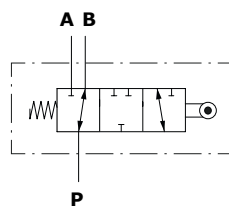

Dimensional data - hydraulic circuit - performance data

6 way

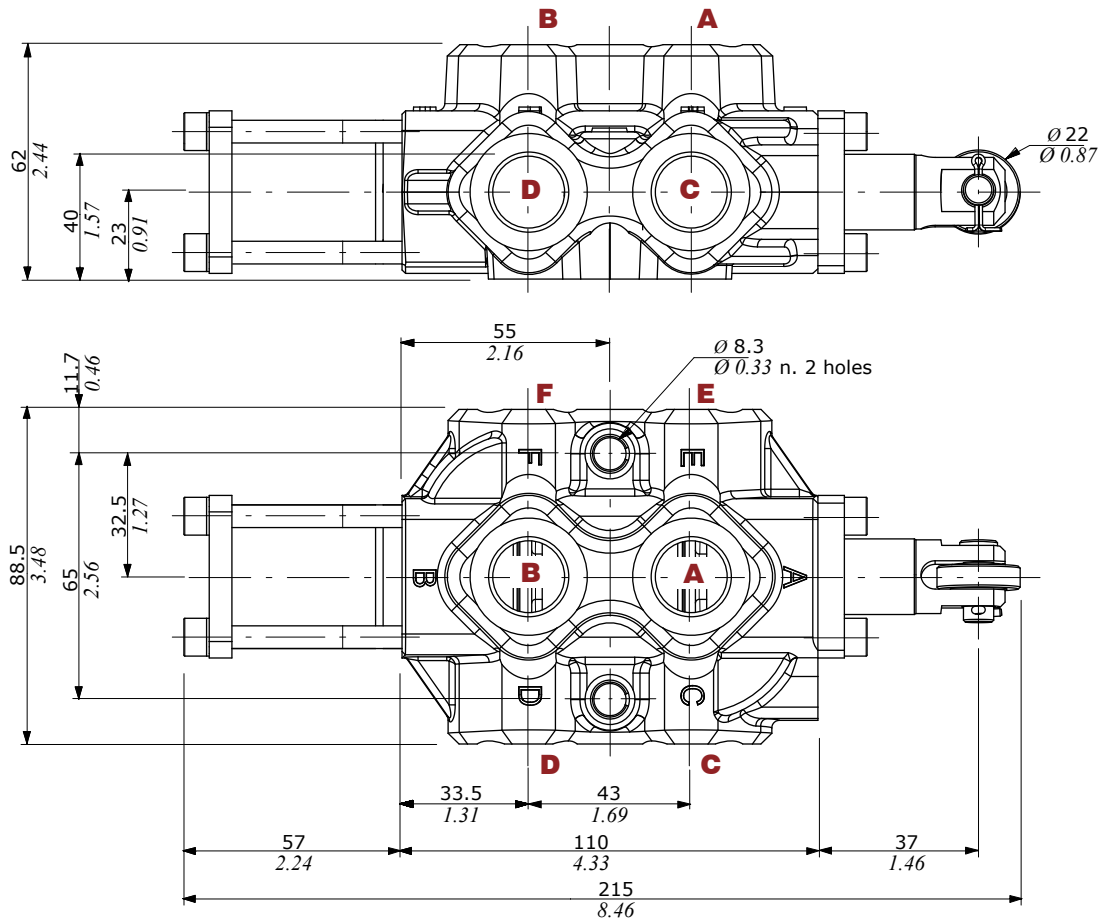

Pressure drop versus flow

A → C(E)

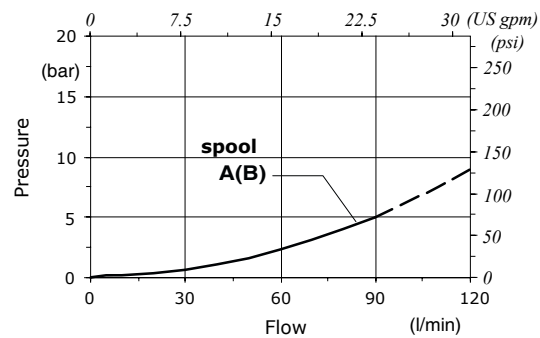
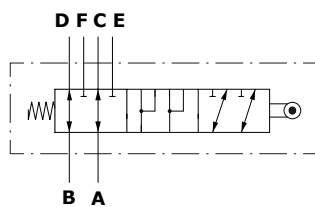

Part ordering codes

Example:

DFC100/3 **B** **17G** **SLP** - **SAE** - **(CVN)**

1

2

3

4

5

Painted with one layer of black Primer antirust

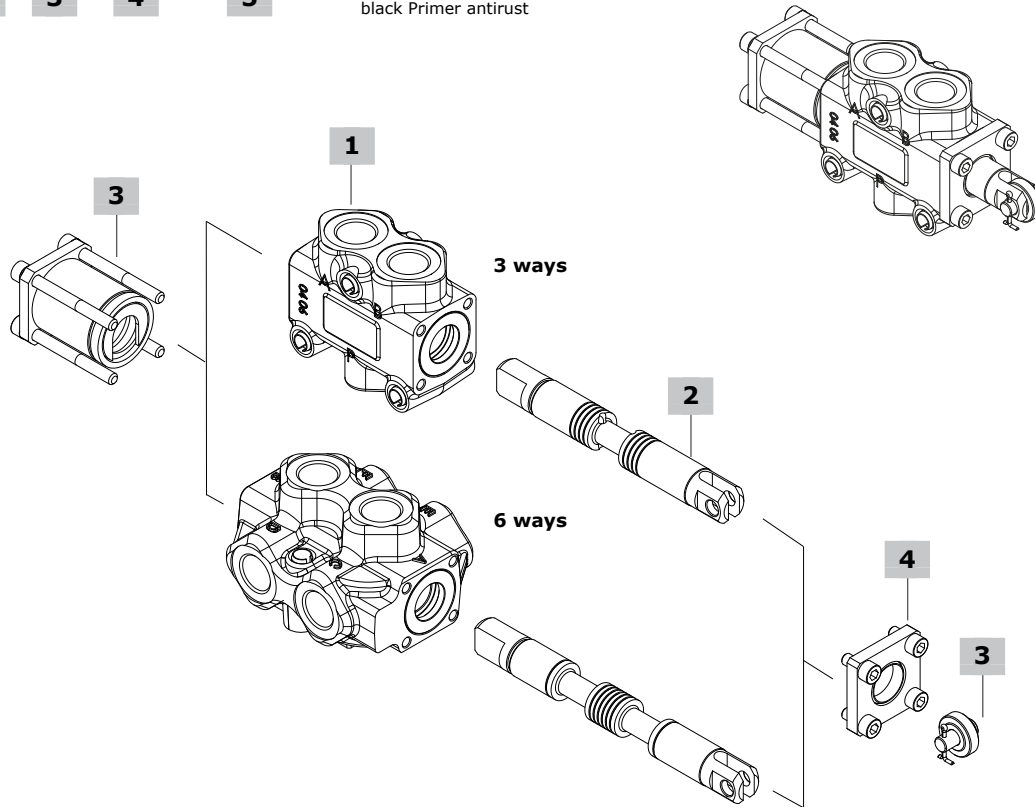

1 Body kit*

TYPE	CODE	DESCRIPTION
DFC100/3	5CO2241713	3 ways body kit
DFC100/6	5CO2242711	6 ways body kit

2 Spools page 39

TYPE	CODE	DESCRIPTION
for DFC100/3:		
A	3CAS110312	Ports connected in transit position
B	3CAS110421	Ports closed in transit position
for DFC100/6:		
A	3CAS110711	Flow in C and D. E and F closed in pos. 1 Ports connected in transit position
B	3CAS110721	Flow in C and D. E and F closed in pos. 1 Ports closed in transit position

3 Complete controls page 40

TYPE	CODE	DESCRIPTION
17G	5V17910000	Cam control with spring return in pos. 1
17GCAX	5V17910001	Inox steel cam control with spring return in pos. 1

4 "B" side options page 40

TYPE	CODE	DESCRIPTION
SLP	5COP110005	with dust-proof plate

5 Body threading

Specify threading always when it is different from **BSP** standard

(*) - Codes are referred to **UN-UNF** thread

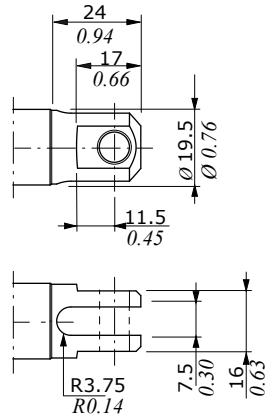

Rotary cam arrangement:
spool type **A, B**

Spool circuits

3 ways

Type A

Ports connected
in transit position

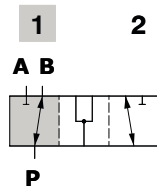

Spool stroke

Position 2: - 14 mm (- 0.55 in)

Type B

Ports closed
in transit position

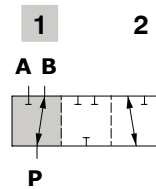

Spool stroke

Position 2: - 14 mm (- 0.55 in)

6 ways

Type A

Flow in C and D. E and F closed in pos. 1
Ports connected in transit position

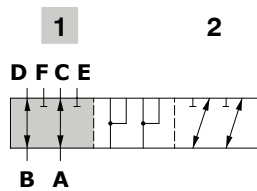

Spool stroke

Position 2: - 14 mm (- 0.55 in)

Type B

Flow in C and D. E and F closed in pos. 1
Ports closed in transit position

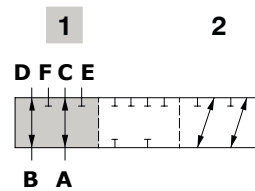

Spool stroke

Position 2: - 14 mm (- 0.55 in)

Complete controls

Cam control kit

17G type cam control available with stainless steel bearing (type 17GCAX).
It must be coupled with type SLP flange on valve B side

Type 17G - 17GCAX

Spring return in pos.1

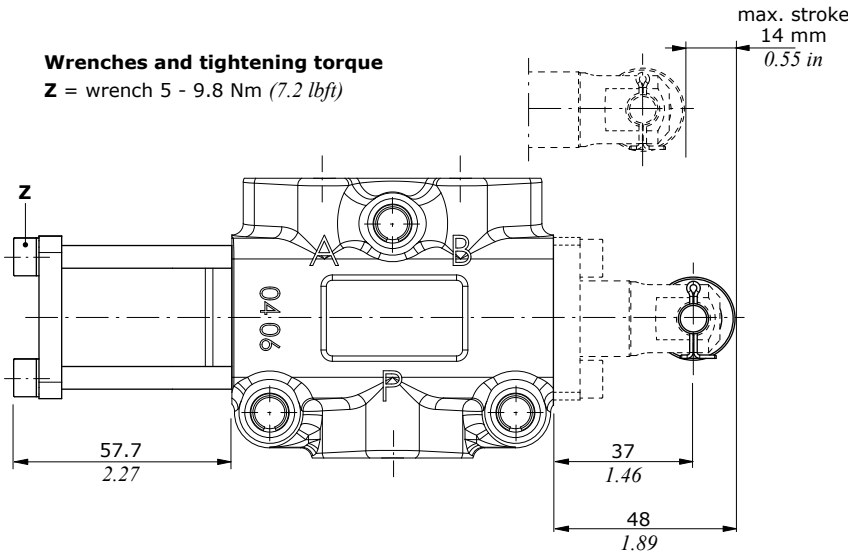
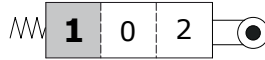

Force-Stroke diagram

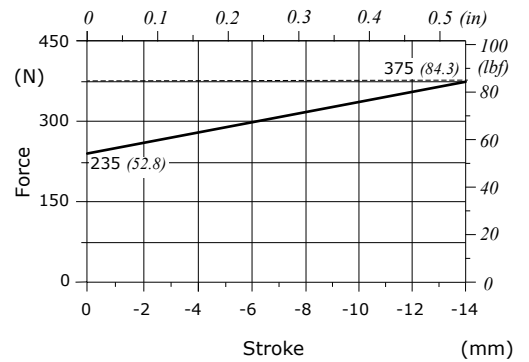

"B" side options

Without lever, with flange

Type SLP

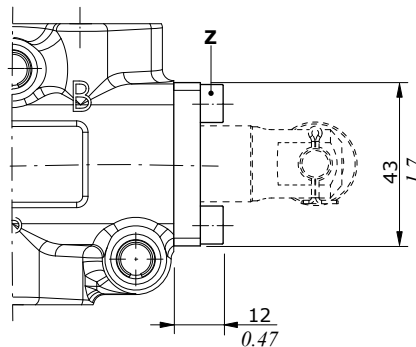
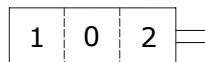

Wrenches and tightening torque

Z = wrench 5 - 9.8 Nm (7.2 lbf ft)



DF20

Mechanical control monoblock diverter valves

- 3 - 6 ways configuration
- Mechanical lever, cam, hydraulic, electrohydraulic, pneumatic controls

This catalogue shows technical specifications and diagrams measured with mineral oil of 46 mm²/s (46 cSt) viscosity at 40°C - (104°F) temperature.

WORKING CONDITIONS		
N. of available ways		3 - 6
Max. flow rating		140 l/min (37 US gpm)
Max. pressure		315 bar (4600 psi)
Internal leakage A(B)⇒T	$\Delta p = 100 \text{ bar (1450 psi)}$	8 cm ³ /min (0.48 in ³ /min)
Fluid		Mineral based oil
Fluid temperature	with NBR (BUNA-N) seals	from -20°C to 80°C (from -4°F to 176°F)
	with FPM (VITON) seals	from -20°C to 100°C (from -4°F to 212°F)
Viscosity	operating range	from 15 to 75 mm ² /s (from 15 to 75 cSt)
	min.	12 mm ² /s (12 cSt)
	max.	400 mm ² /s (400 cSt)
Max. level of contamination		21/19/16 - ISO 4406 - NAS 1638 - class 10
Ambient temperature for working conditions	with mechanical controls	from -40°C to 60°C (from -40°F to 140°F)
	with hydraulic and pneumatic controls	from -30°C to 60°C (from -22°F to 140°F)
	with electric controls	from -20°C to 50°C (from -4°F to 122°F)

NOTE - For different working conditions please contact Sales Dept.

Available threads

PORTS THREAD		
ALL PORTS	BSP	UN-UNF
DF20	G 3/4	1" 1/16-12 (SAE 12)
PILOT PORTS		
Pneumatic	NPT 1/8-27	NPT 1/8-27
Hydraulic	G 1/4	9/16-18 (SAE 6)

Dimensional data - hydraulic circuit - performance data

3 ways

It's possible to obtain 2 ways diverter valve plugging port

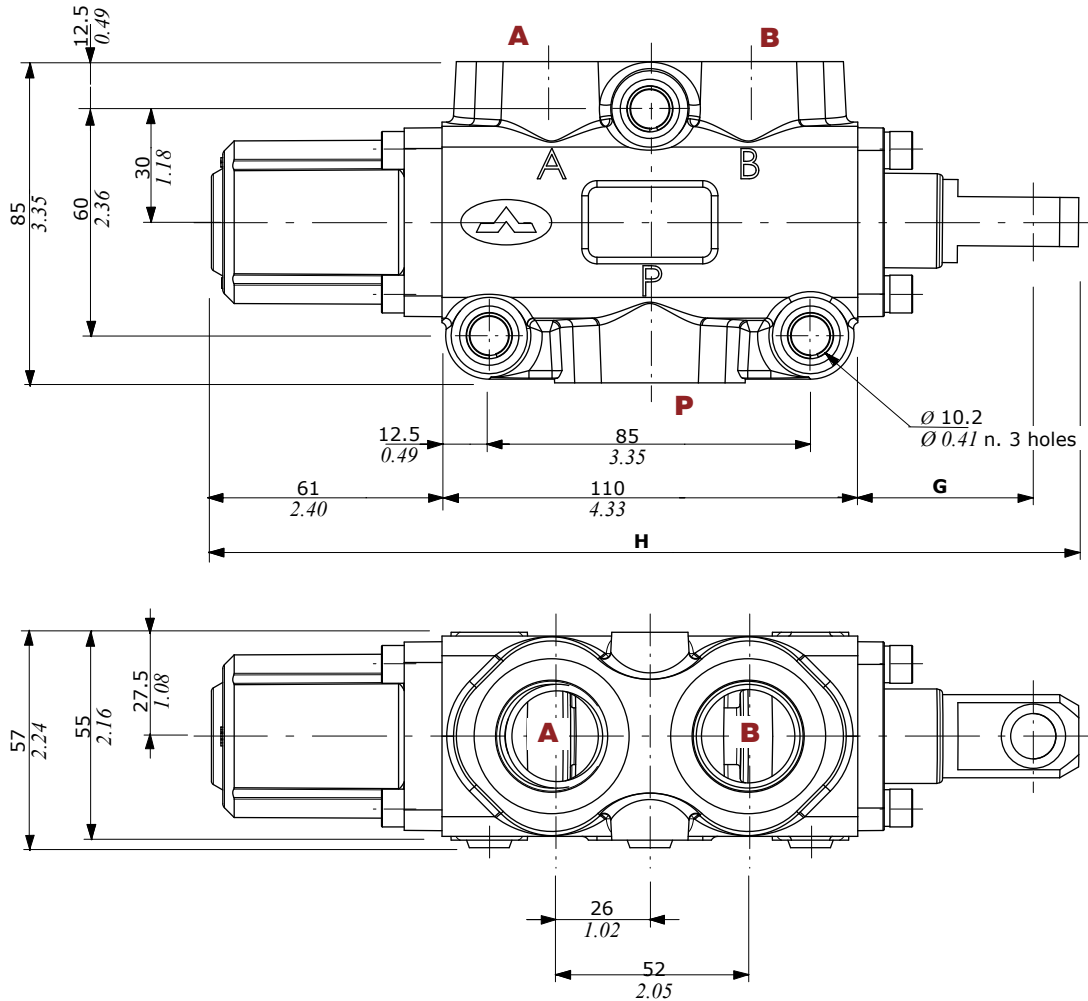

	G	H
With spool out	55 mm 2.16 in	238 mm 9.37 in
With spool in	35 mm 1.37 in	218 mm 8.58 in

Pressure drop versus flow

P → A(B)

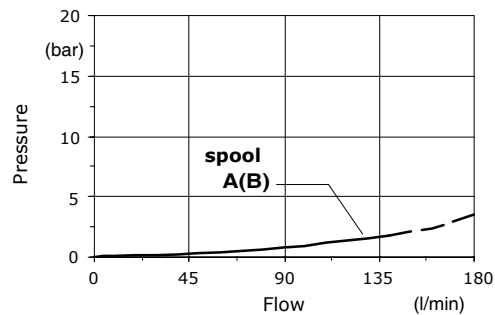
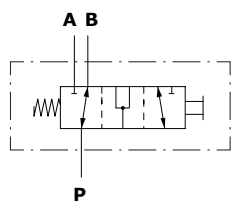

Dimensional data - hydraulic circuit - performance data

6 ways

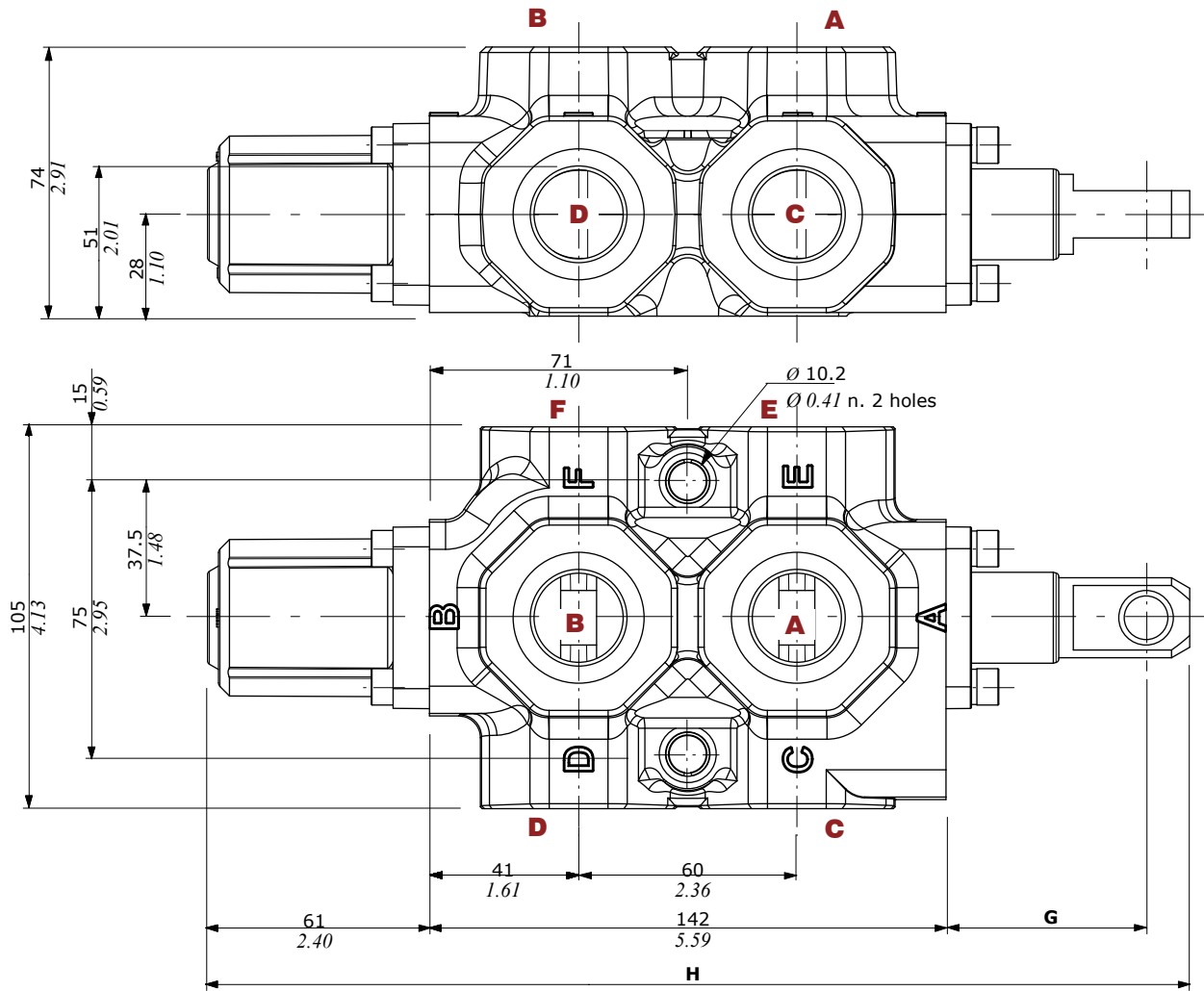

	G	H
With spool out	55 mm 2.16 in	270 mm 10.6 in
With spool in	35 mm 1.37 in	250 mm 9.84 in

Pressure drop versus flow
A → C(E)

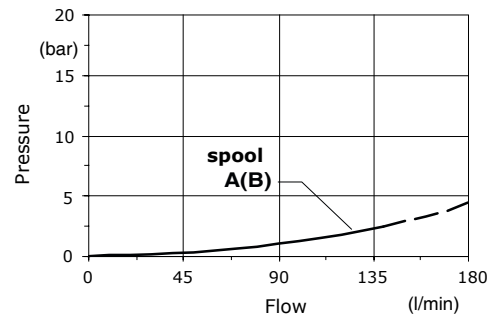
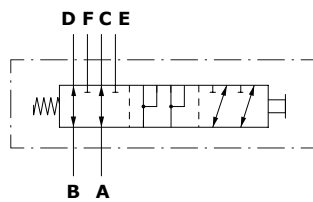

Part ordering codes

Example:

DF20/3 **A** **17** **SLP** - **SAE** - **(CVN)**

1

2

3

4

5

Painted with one layer of black Primer antirust

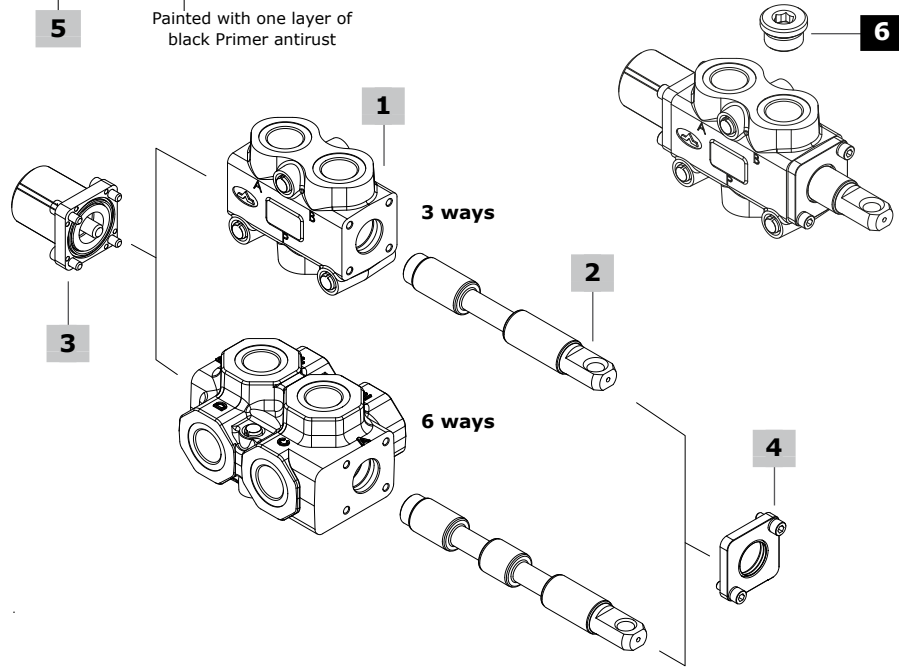

1 Body kit*

TYPE	CODE	DESCRIPTION
DF20/3	5CO2261700	3 ways body kit
DF20/6	5CO2263700	6 ways body kit

2 Spools

page 45

TYPE	CODE	DESCRIPTION
for DF20/3:		
A	3CAS120310	Flow in B in pos. 1. Ports connected in transit position
B	3CAS120410	Flow in B in pos. 1. Ports closed in transit position
AC	3CAS120320	As type A, for cam control
BC	3CAS120420	As type B, for cam control

for DF20/6:

A	3CAS120610	Flow in C and D. E and F closed in pos. 1. Ports connected in transit position
B	3CAS120710	Flow in C and D. E and F closed in pos. 1. Ports closed in transit position
AC	3CAS120620	As type A, for cam control

3 "A" side spool positioners

page 46

TYPE	CODE	DESCRIPTION
12	5V12120000	Detent in positions 1 and 2
17	5V17120000	Spring return in position 1
17ME	5V17320000	As kit 17, with heavier spring type E
18	5V18120000	Spring return in position 2

Pneumatic controls: must be coupled to the control kit side B with lever, with plate or cap

17P	5V17110700	On/off, with spring return in pos. 1
18P	5V18120700	On/off, with spring return in pos. 2
18PNCWP	5V18120713	On/off, with spring return in pos. 2, waterproof

3 "A" side spool positioners (cont.) page 46

Hydraulic controls: must be coupled to the control kit side B with lever, with plate or cap

18IA1	5V18120825*	On/off high pressure hydraulic kit with spring return in position 2
18IB1	5V18120815*	On/off low pressure hydraulic kit with spring return in position 2

Electrohydraulic controls: must be coupled to the control kit side B with lever, with plate or cap

Control requires collector kit; see page 50

18E11	5V18120350	Spring return in pos. 2, 12VDC
	5V18120351	Spring return in pos. 2, 24VDC

4 "B" side options

page 51

TYPE	CODE	DESCRIPTION
SLP	5COP120000	Without lever box, with dust-proof plate kit
SLC	5COP220000	Without lever box, with cap
L	5LEV120000	Aluminum lever box
CA	5CAM120000	Steel ball bearing cam operation
CB	5CAM120020	Bronze cam operation

Hydraulic controls

IA2	5IDR520700*	On/off with high pressure pilot, need 17ME control type
IB2	5IDR720700*	On/off with low pressure pilot, need 17ME control type

5 Body threading

Specify threading always when it is different from **BSP** standard

6 Port plugs*

CODE	DESCRIPTION
3XTAP832200	SAE12 plug

(*) - Codes are referred to **UN-UNF** thread

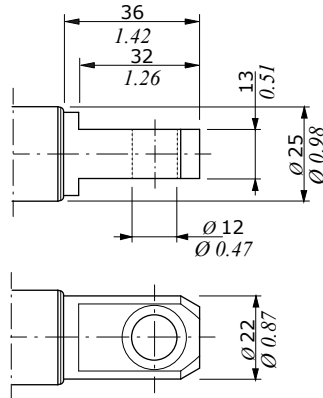

Standard:
spool type **A, B**

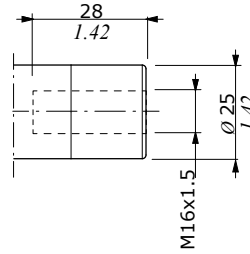

Rotary cam arrangement:
spool type **AC, BC**

Spool circuits

3 ways

Type A/AC

Ports connected
in transit position

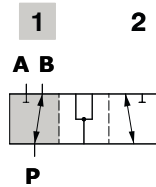

Spool stroke

Position 2: - 20 mm (- 0.78 in)

Type B/BC

Ports closed
in transit position

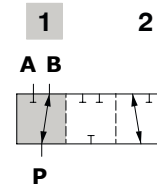

Spool stroke

Position 2: - 20 mm (- 0.78 in)

6 ways

Type A/AC

Flow in C and D. E and F closed in pos. 1
Ports connected in transit position

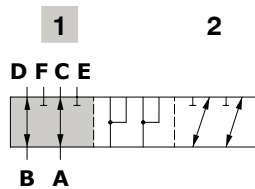

Spool stroke

Position 2: - 20 mm (- 0.78 in)

Type B

Flow in C and D. E and F closed in pos. 1
Ports closed in transit position

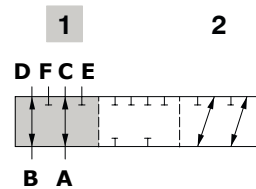

Spool stroke

Position 2: - 20 mm (- 0.78 in)

"A" side spool positioners

With detent

Type 12

Detent in positions 1 and 2

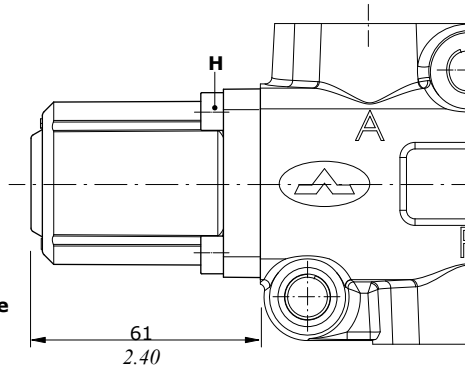
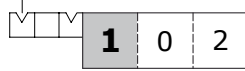

Wrenches and tightening torque
 H = wrench 5 - 9.8 Nm (7.2 lbf)

With spring return in position 1

With heavier spring type "E"

Type 17

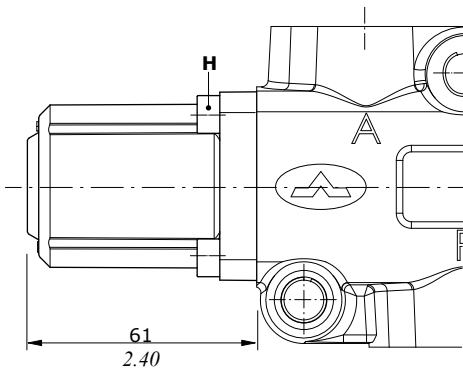
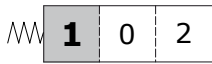

Type 17ME

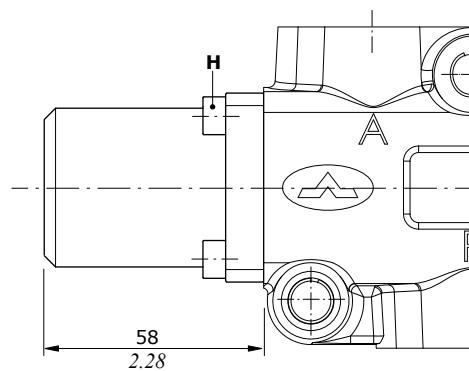

Wrenches and tightening torque
 H = wrench 5 - 9.8 Nm (7.2 lbf)

Force-Stroke diagram

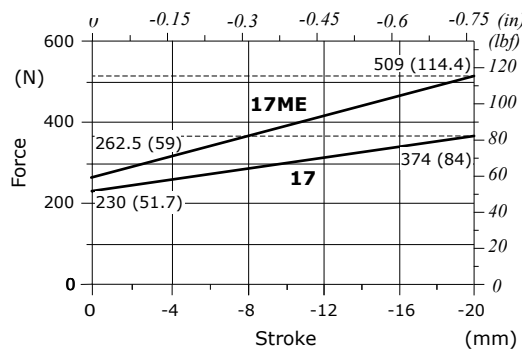

"A" side spool positioners

With spring return in position 2

Type 18

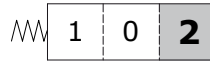

Wrenches and tightening torque

H = wrench 5 - 9.8 Nm (7.2 lbf^t)

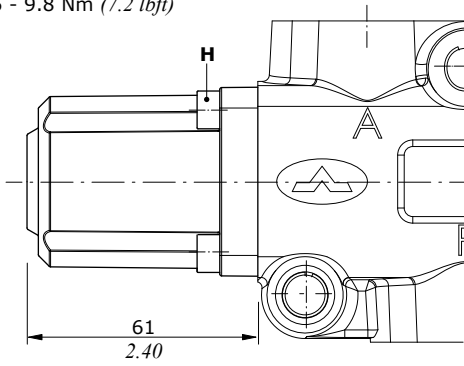

Force-Stroke diagram

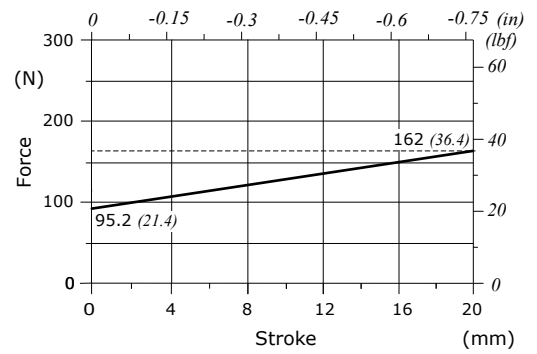

ON/OFF pneumatic controls

Type 17P

Spring return in position 1

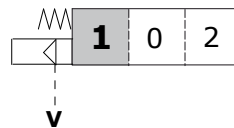

Wrenches and tightening torque

H = wrench 5 - 9.8 Nm (7.2 lbf^t)

J = wrench 13 - 9.8 Nm (7.2 lbf^t)

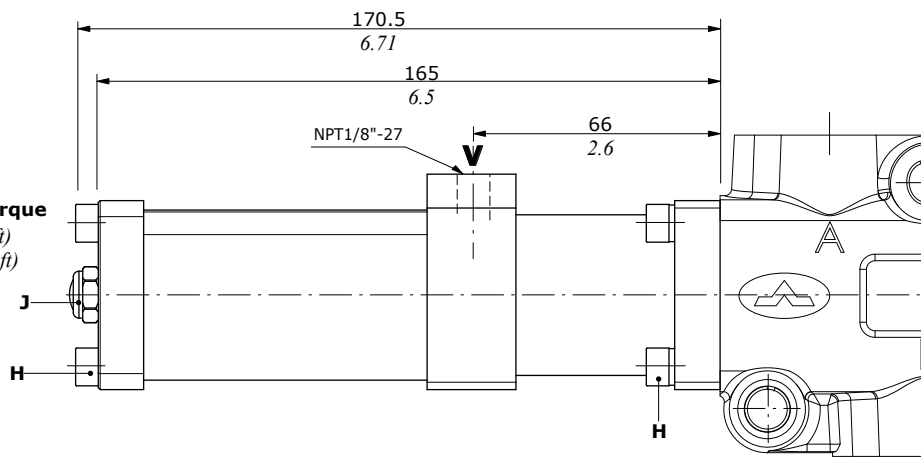

Pilot pressure... : min. 7 bar (101 psi) - max. 10 bar (145 psi)

"A" side spool positioners

ON/OFF pneumatic controls

Type 18P

Spring return in position 2

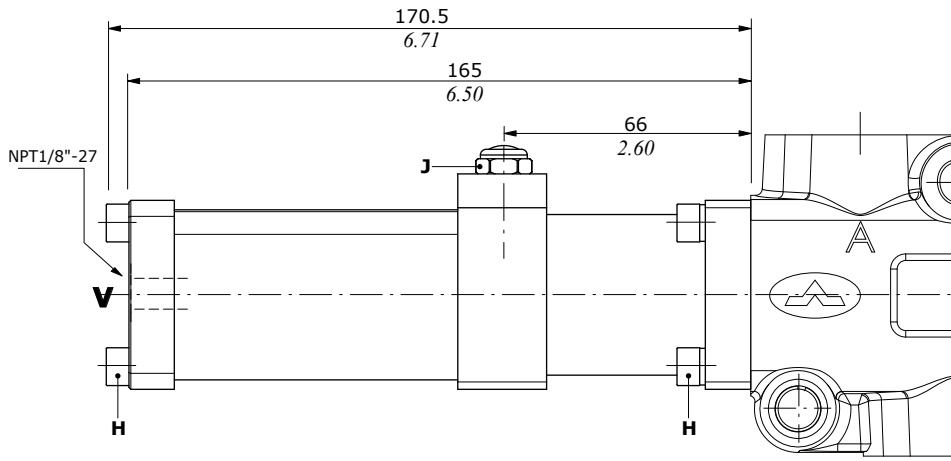
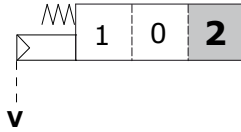

Pilot pressure... : min. 7 bar (101 psi) - max. 10 bar (145 psi)

Wrenches and tightening torque

H = wrench 5 - 9.8 Nm (7.2 lbft)

J = wrench 13 - 9.8 Nm (7.2 lbft)

Type 18PNCWP

Spring return in position 2, waterproof

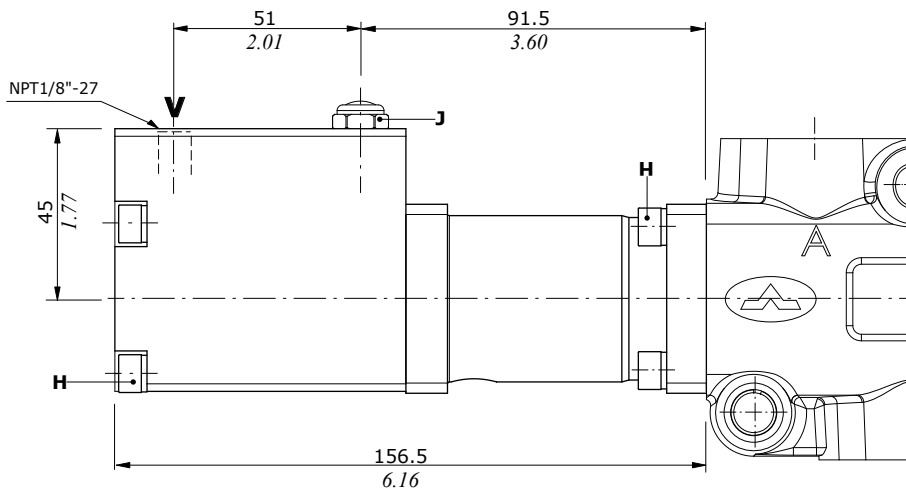
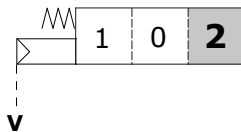

"A" side spool positioners

Hydraulic controls

Type 18IA1

High pressure hydraulic kit with spring return in position 2

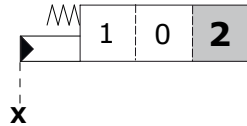

Type 18IB1

Low pressure hydraulic kit with spring return in position 2

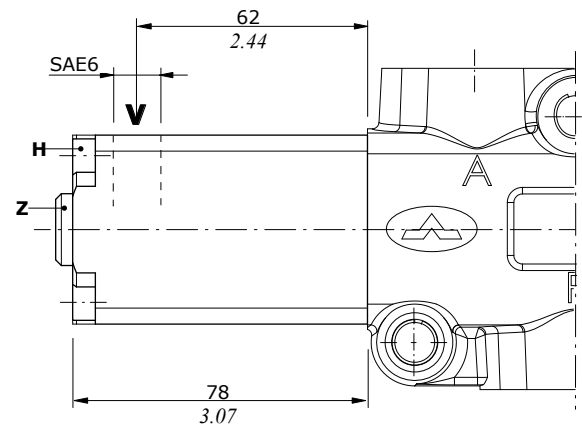
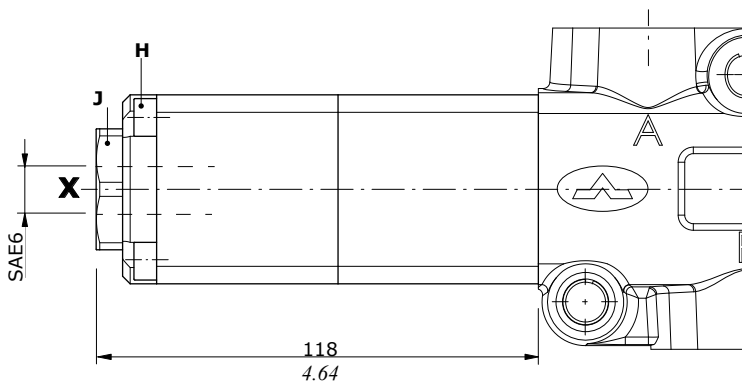
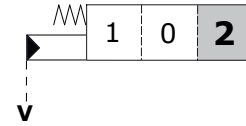

Pilot pressure... : min. 30 bar (435 psi) - max. 250 bar (3620 psi)

Pilot pressure... : min. 15 bar (217 psi) - max. 50 bar (725 psi)

Wrenches and tightening torque

H = wrench 5 - 9.8 Nm (7.2 lbf·ft)

Z = wrench 6 - 24 Nm (17.7 lbf·ft)

J = wrench 32 - 42 Nm (31 lbf·ft)

"A" side spool positioners

ON/OFF electrohydraulic control

Type 18EI1

Spring return in pos. 2,
with external pilot and drain

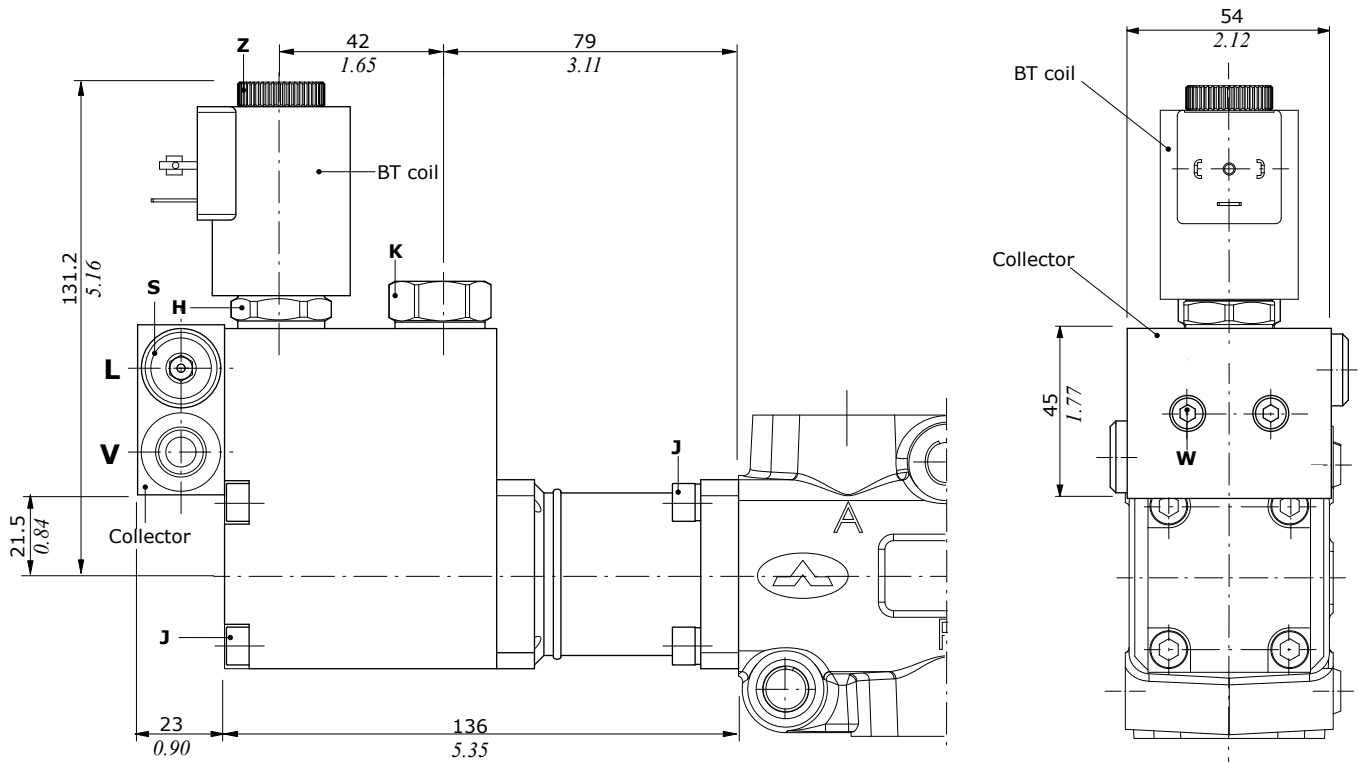
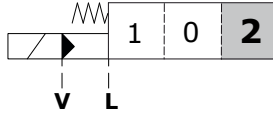

Wrenches and tightening torque

- J = wrench 5 - 9.8 Nm (7.2 lbft)
 - K = wrench 24 - 30 Nm (22.1 lbft)
 - Z = 5 Nm (3.68 lbft)
 - S = wrench 6 - 24 Nm (17.7 lbft)
 - H* = wrench 24 - 9.8 Nm (7.2 lbft)
 - W = wrench 4 - 6.6 Nm (4.9 lbft)
- (*)Tightening with dynamometric wrench or screwer

Features

- Pilot pressure: : min. 10 bar (145) psi
- : max. 50 bar (725) psi
- Max backpressure on drain L... : 25 bar (362.5) psi

Note: for complete available BT coils list and features see page 53

Collector kit for external pilot and drain

COLLECTOR KIT CODE		
Type	Code	Description

KE1S0 5KE1S00070 kit for 1 section

Codes are referred to UN-UNF thread

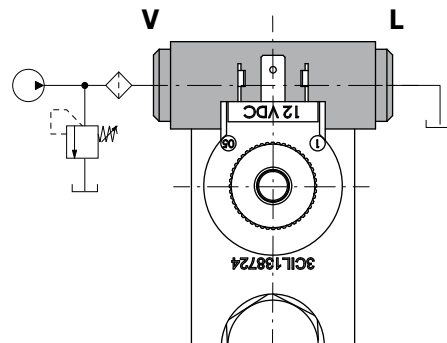

"B" side options

Lever control kit

Aluminium with protection boot lever pivot box; it can be rotated 180° (execution **L180**)

Type L

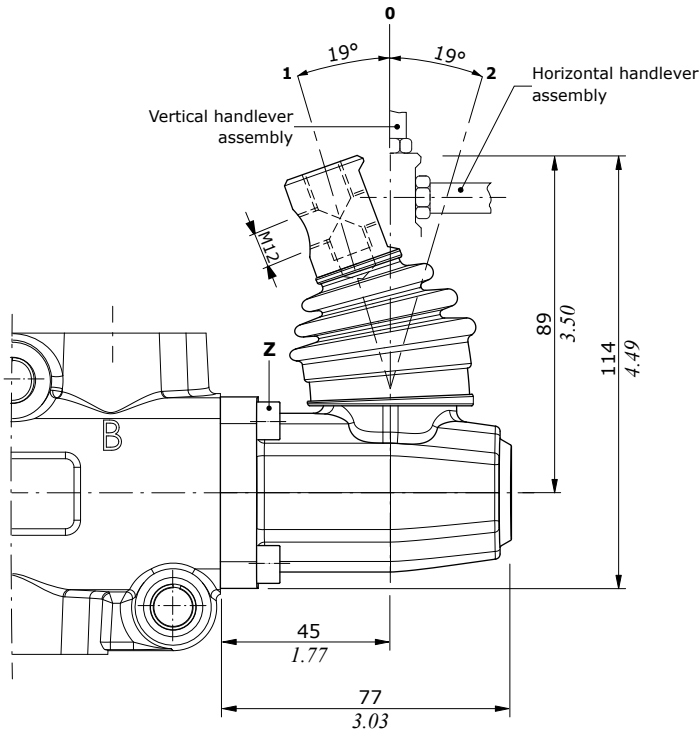
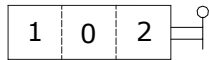

Without lever, with flange

Type SLP

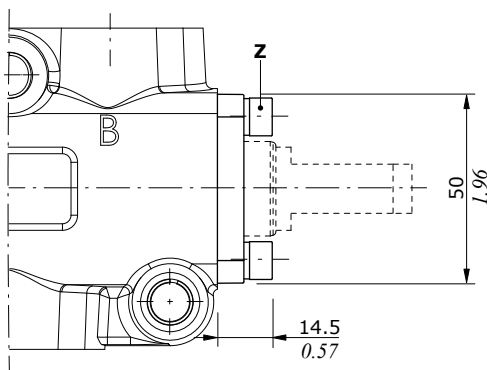
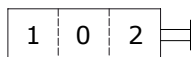

Wrenches and tightening torque

Z = wrench 5 - 9.8 Nm (7.2 lbf·ft)

W = wrench 8 - 24 Nm (7.2 lbf·ft)

Cam control kit

Steel ball bearing cam operation (CA), and bronze cam operation (CB); it must be coupled to 17 control kit

Type CA-CB

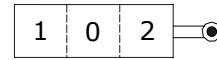

Wrenches and tightening torque

Z = wrench 5 - 9.8 Nm (7.2 lbf·ft)

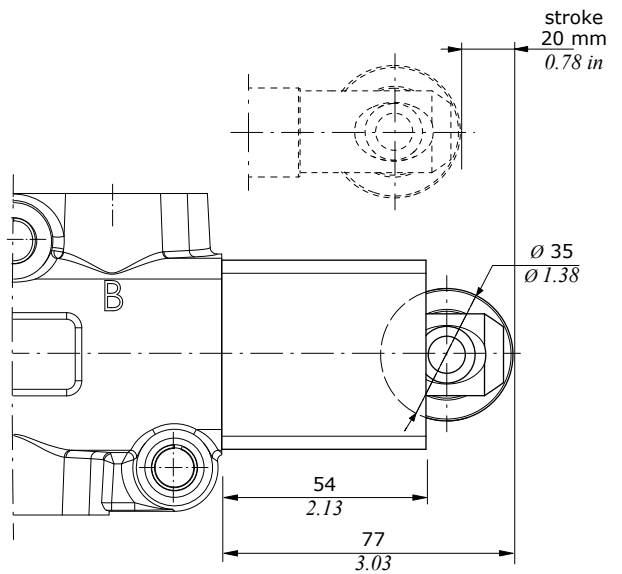

Without lever, with cap

Protection cap to use with pneumatic, hydraulic and electrohydraulic spool positioner kits

Type SLC

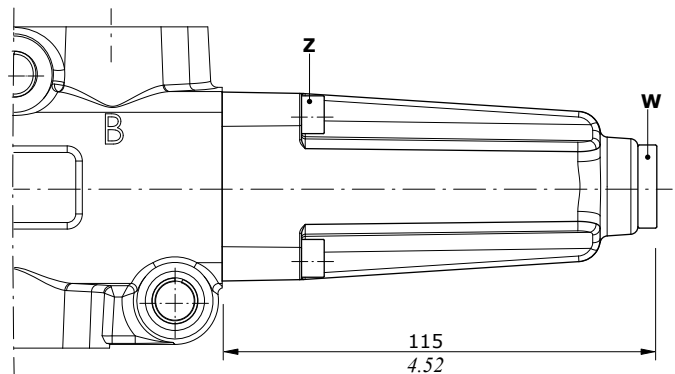
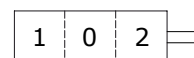

"B" side options

Hydraulic controls

ON/OFF controls with high and low pressure pilot it must be only coupled to 17ME control kit

Type IA2
High pressure pilot

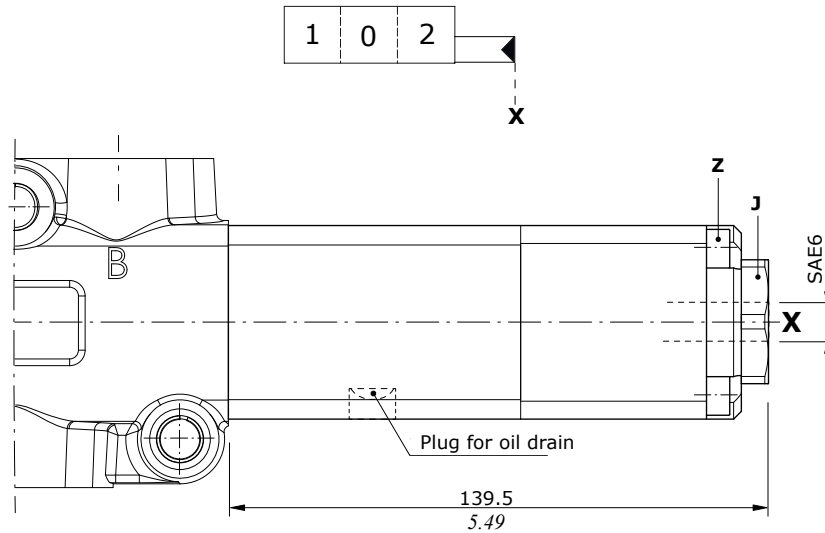

Wrenches and tightening torque

- Z = wrench 5 - 9.8 Nm (7.2 lbf^t)
- J = wrench 24 - 42 Nm (31 lbf^t)
- Q = wrench 6 - 24 Nm (17.7 lbf^t)

Pilot pressure... : min. 30 bar (435 psi) - max. 250 bar (3620 psi)

Type IB2
Low pressure pilot

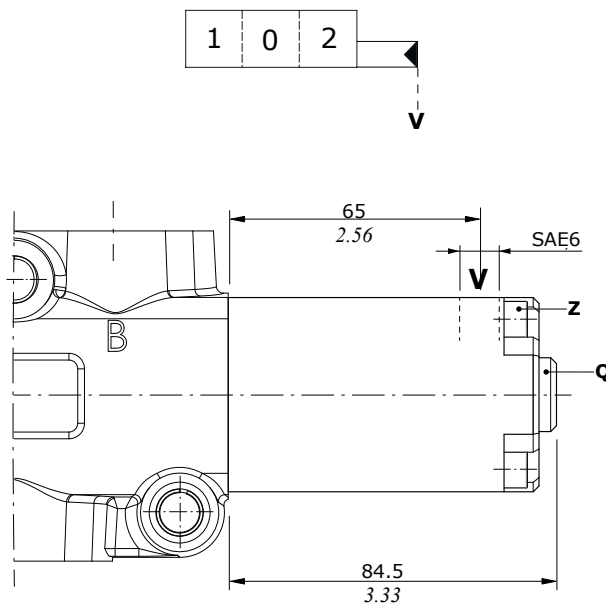

Pilot pressure... : min. 15 bar (217 psi) - max. 50 bar (725 psi)

Coils and accessories for 18E11 control

		Ordering codes					
Type	Voltage	Connector types					
		ISO4400	Deutsch DT	AMP JPT	Packard Weatherpack	Packard Metri-pack	Flying leads without connector
BT	10 VDC	4SL3000100	-	-	-	-	-
	12 VDC	4SL3000120	4SL3000130 ⁽⁶⁾	4SL3000122 ⁽⁵⁾	4SL3000124 ⁽²⁾	4SL3000127 ⁽²⁾	4SL300012C
		4SL3000126 ⁽⁴⁾	4SL3000134 ⁽³⁻⁶⁾	4SL3001200 ⁽³⁻⁵⁾	-	-	-
	24 VDC	4SL3000240	4SL3000249 ⁽⁶⁾	4SL3000248 ⁽⁵⁾	-	-	4SL3000246
		4SL3030240 ⁽¹⁾	4SL300024C ⁽³⁻⁶⁾	-	-	-	-
	26 VDC	4SL3000260	-	-	-	-	-
	48 VDC	4SL3000480	-	-	-	-	-
		4SL3030480 ⁽¹⁾	-	-	-	-	-
110 VDC	4SL3001100	-	-	-	-	-	
	4SL3031100 ⁽¹⁾	-	-	-	-	-	
220 VDC	4SLE022000A	-	-	-	-	-	
	4SLE322000A ⁽¹⁾	-	-	-	-	-	
Mating connectors							
With rectifier		4CN1009995	5CON140031	5CON003	5CON001	5CON017	-
	24 VDC	4CN3010240	-	-	-	-	-
	48 VDC	4CN3010480	-	-	-	-	-
	110 VDC	4CN3011100	-	-	-	-	-
	220 VDC	4CN3012200	-	-	-	-	-

Notes: ⁽¹⁾ supply with AC and use only with rectifier connector - ⁽²⁾ with flying leads - ⁽³⁾ with bidirectional diode - ⁽⁴⁾ with unidirectional diode - ⁽⁵⁾ integrated perpendicular type - ⁽⁶⁾ integrated parallel type

Features

- Nominal voltage tolerance: ±10%
- Nominal power..... : 19 W - 10 VDC
- : 21 W - 12/24/26 VDC
- : 20.3 W - 48 VDC
- : 17.3 W - 110 VDC
- : 17.7 W - 220 VDC
- Nominal current..... : 1.9 A @ 10 VDC
- : 1.77 A @ 12 VDC
- : 0.89 A @ 24VDC
- : 0.84 A @ 26 VDC
- : 0.43 A @ 48 VDC
- : 0.16 A @ 110 VDC
- : 0.08 A @ 220 VDC
- Insulation..... : Class F (155°C - 311°F)
- Weather protection... : IP65 - ISO4400 / AMP JPT
- : IP69K - Deutsch DT
- : IP67 - Weatherpack / Metri-pack
- Insertion..... : 100%

ISO4400 connector

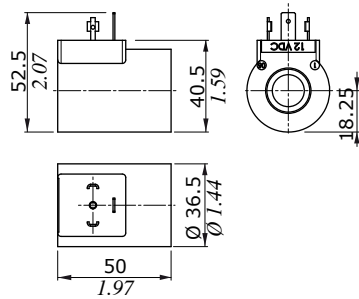

DEUTSCH DT04 connector (Parallel type)

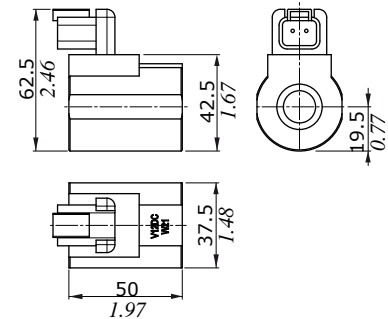

Flying leads

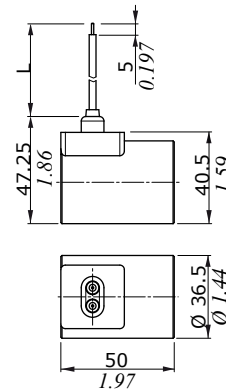

AMP JPT connector (Perpendicular type)

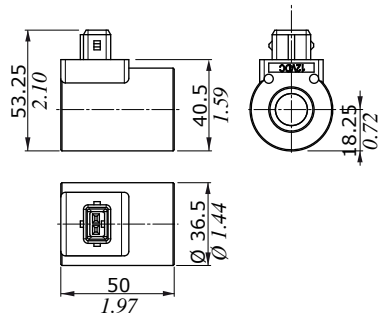

Coil type	L dimension	
	(mm)	(in)
12 VDC	240	9.45
24 VDC	600	23.62

Coils and accessories for 18E11 control

Flying leads with DEUTSCH DT04 connector

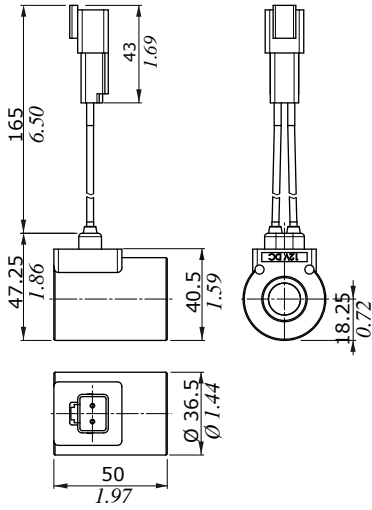

Flying leads with PACKARD METRI-PACK connector Flying leads with PACKARD WEATHER-PACK connector

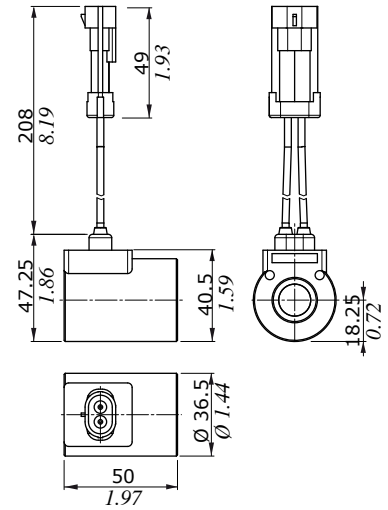
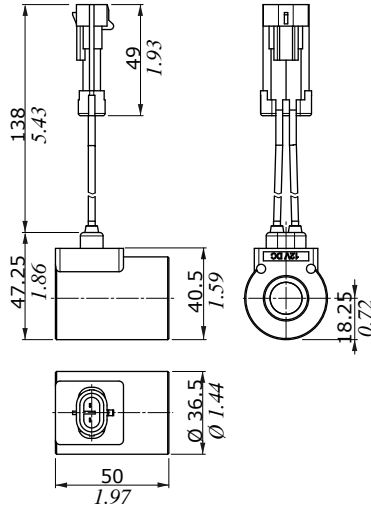



DF25

Mechanical control monoblock diverter valve

- 3 ways configuration
- Mechanical lever, cam, electrohydraulic, pneumatic controls

This catalogue shows technical specifications and diagrams measured with mineral oil of 46 mm²/s - (46 cSt) viscosity at 40°C - (104°F) temperature.

WORKING CONDITIONS

N. of available ways	3	
Max. flow rating	280 l/min (74 US gpm)	
Max. pressure	315 bar (4600 psi)	
Internal leakage A(B)⇒T	$\Delta p = 100 \text{ bar (1450 psi)}$	8 cm ³ /min (0.48 in ³ /min)
Fluid	Mineral based oil	
Fluid temperature	with NBR (BUNA-N) seals	from -20°C to 80°C (from -4°F to 176°F)
	with FPM (VITON) seals	from -20°C to 100°C (from -4°F to 212°F)
Viscosity	operating range	from 15 to 75 mm ² /s (from 15 to 75 cSt)
	min.	12 mm ² /s (12 cSt)
	max.	400 mm ² /s (400 cSt)
Max. level of contamination	21/19/16 - ISO 4406 - NAS 1638 - class 10	
Ambient temperature for working conditions	with mechanical controls	from -40°C to 60°C (from -40°F to 140°F)
	with hydraulic and pneumatic controls	from -30°C to 60°C (from -22°F to 140°F)
	with electric controls	from -20°C to 50°C (from -4°F to 122°F)

NOTE - For different working conditions please contact Sales Dept.

Available threads

PORTS THREAD		
ALL PORTS	BSP	UN-UNF
DF25	G 1	1" 5/16-12 (SAE 16)
PILOT PORTS		
Pneumatic	NPT 1/8-27	NPT 1/8-27
Hydraulic	G 1/4	9/16-18 (SAE 6)

Dimensional data - hydraulic circuit - performance data

3 ways

It's possible to obtain 2 ways diverter valve plugging port

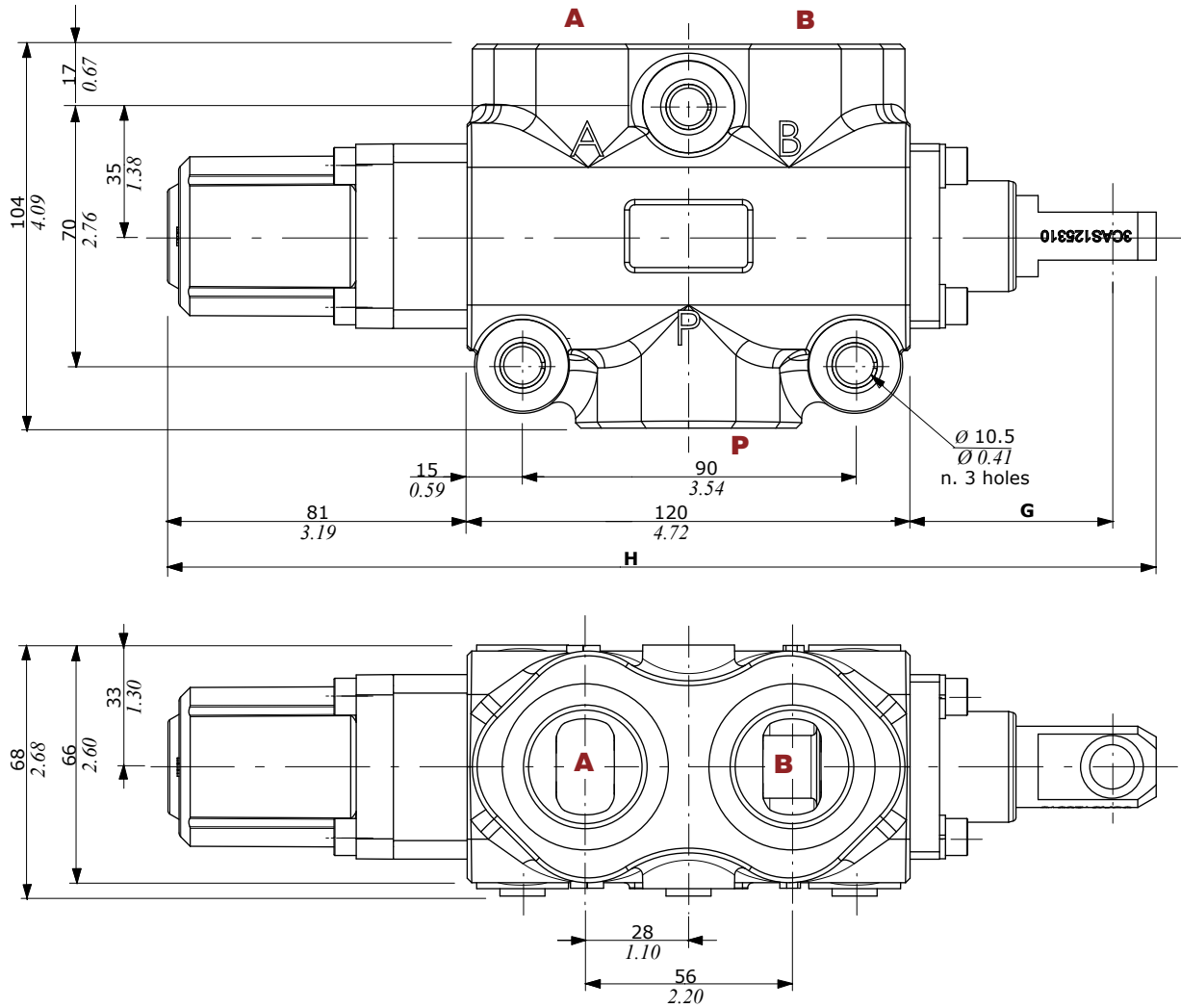

	G	H
With spool out	55 mm 2.16 in	268 mm 10.55 in
With spool in	35 mm 1.37 in	248 mm 9.76 in

Pressure drop versus flow

P → A(B)

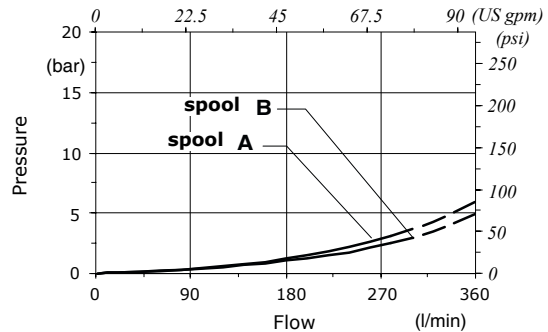
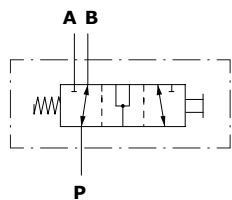

Example:

DF25/3 **A** **17** **SLP** - **SAE** - **(CVN)**
 1 2 3 4 5 Painted with one layer of black Primer antirust

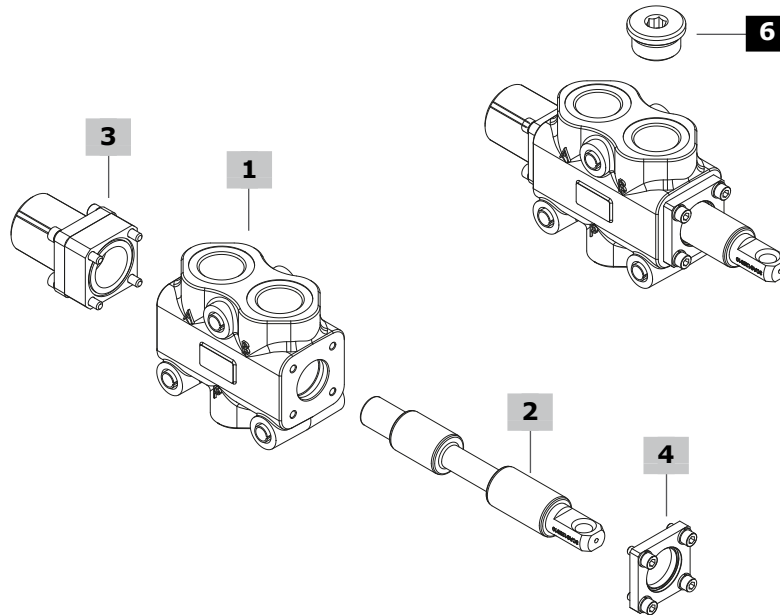

1 Body kit*

TYPE	CODE	DESCRIPTION
DF25/3	5CO2271700	Standard body kit 3 ways

2 Spools **pag. 58**

TYPE	CODE	DESCRIPTION
A	3CAS125310	Flow in B in pos. 1. Ports connected in transit position
B	3CAS125410	Flow in B in pos. 1. Ports closed in transit position
AC	3CAS125320	As type A, for cam control

3 "A" side spool positioners **pag. 58**

TYPE	CODE	DESCRIPTION
12	5V12125000	Detent in positions 1 and 2
17	5V17125000	Spring return in position 1
17ME	5V17325000	As kit 17, with heavier spring type E
<u>Pneumatic controls: must be coupled to the control kit side B with lever, with plate or cap</u>		
17P	5V17125700	On/off, with spring return in position 1
18P	5V18125700	On/off, with spring return in position 2
<u>Electrohydraulic controls: must be coupled to the control kit side B with lever, with plate or cap</u>		
Control requires collector kit; see page 61		
18E11	5V18125350	Spring return in position 2, 12VDC
	5V18125351	Spring return in position 2, 24VDC

4 "B" side options **pag. 62**

TYPE	CODE	DESCRIPTION
SLP	5COP125000	Without lever box, with dust-proof plate kit
SLC	5COP220000	Without lever box, with cap
L	5LEV120000	Aluminum lever box
CA	5CAM125000	Steel ball bearing cam operation
CB	5CAM125020	Bronze cam operation
<u>Hydraulic controls</u>		
IA2	5IDR520700*	On/off with high pressure pilot, need 17ME control type
IB2	5IDR720700*	On/off with low pressure pilot, need 17ME control type

5 Body threading

Specify threading always when it is different from **BSP** standard

6 Port plugs*

CODE	DESCRIPTION
3XTAP838200	SAE16 plug

(*) - Codes are referred to **UN-UNF** thread

Spool end

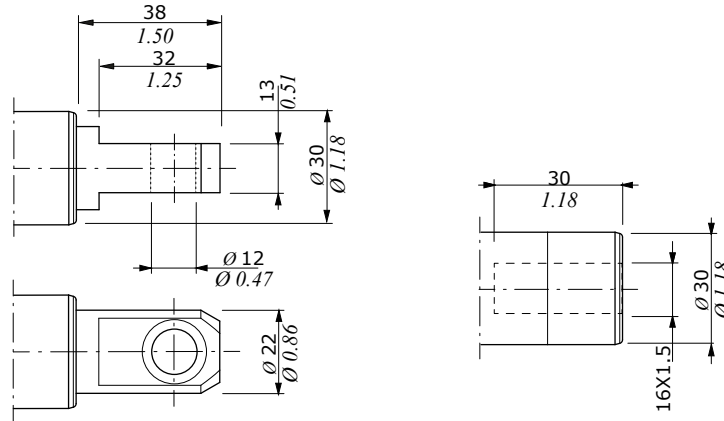

Standard:
spool type **A, B**

Rotary cam arrangement:
spool type **AC**

Spool circuits

Type A/AC

Ports connected
in transit position

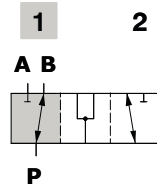

Spool stroke

Position 2: - 20 mm (-0.78 in)

Type B

Ports closed
in transit position

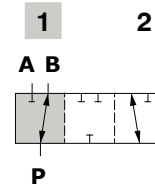

Spool stroke

Position 2: - 20 mm (-0.78 in)

"A" side spool positioners

With detent

Type 12

Detent in positions 1 and 2

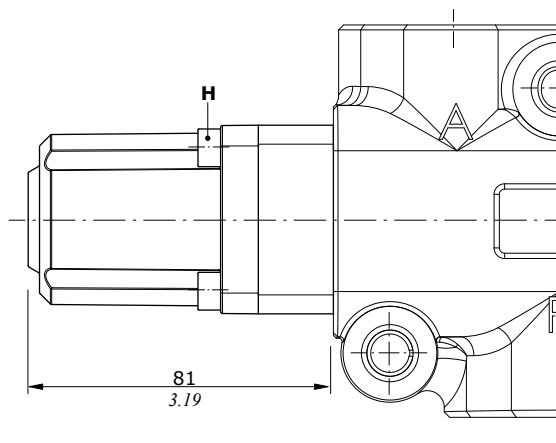
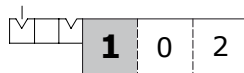

Wrenches and tightening torque

H = wrench 5 - 9.8 Nm (7.2 lbf_t)

"A" side spool positioners

With spring return in position 1

With heavier spring type "E"

Type 17

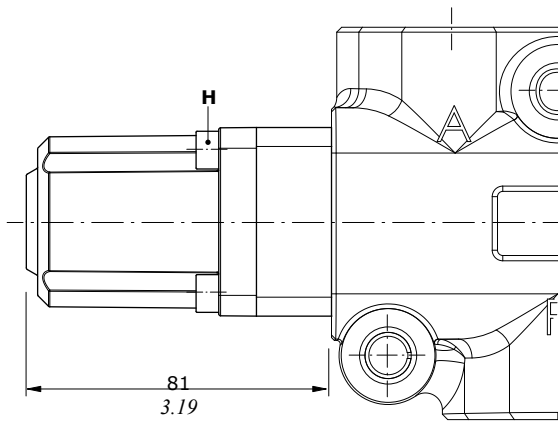

Type 17ME

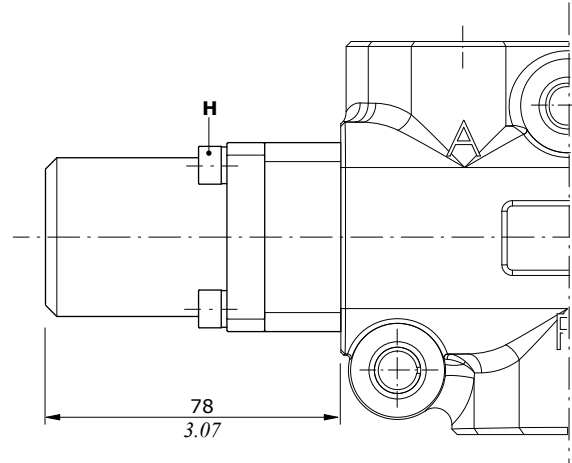

Wrenches and tightening torque

H = wrench 5 - 9.8 Nm (7.2 lbf^t)

Force-Stroke diagram

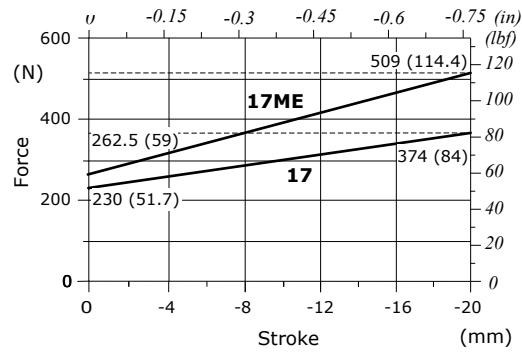

"A" side spool positioners

ON/OFF pneumatic controls

Type 17P

Spring return in position 1

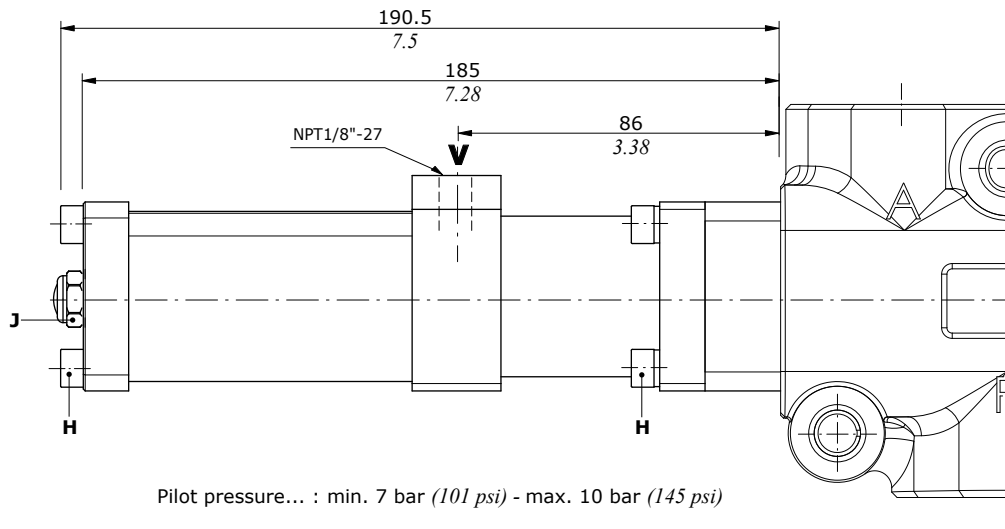
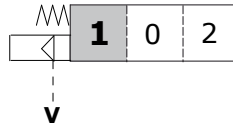

Pilot pressure... : min. 7 bar (101 psi) - max. 10 bar (145 psi)

Wrenches and tightening torque

H = wrench 5 - 9.8 Nm (7.2 lbf^t)

J = wrench 13 - 9.8 Nm (7.2 lbf^t)

Type 18P

Spring return in position 2

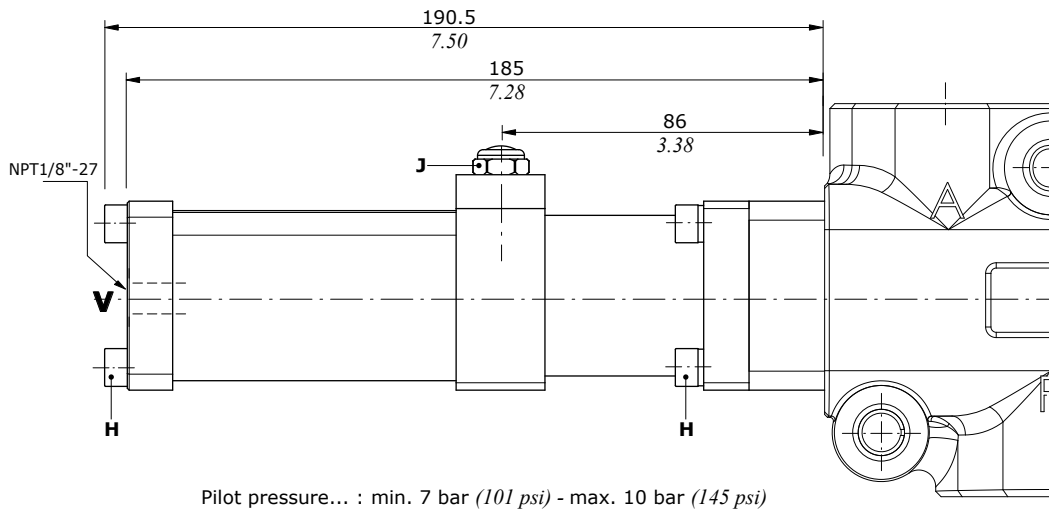
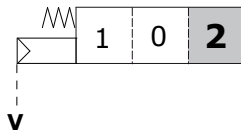

Pilot pressure... : min. 7 bar (101 psi) - max. 10 bar (145 psi)

"A" side spool positioners

ON/OFF electrohydraulic control

Type 18EI1

Spring return in pos. 2,
with external pilot and drain

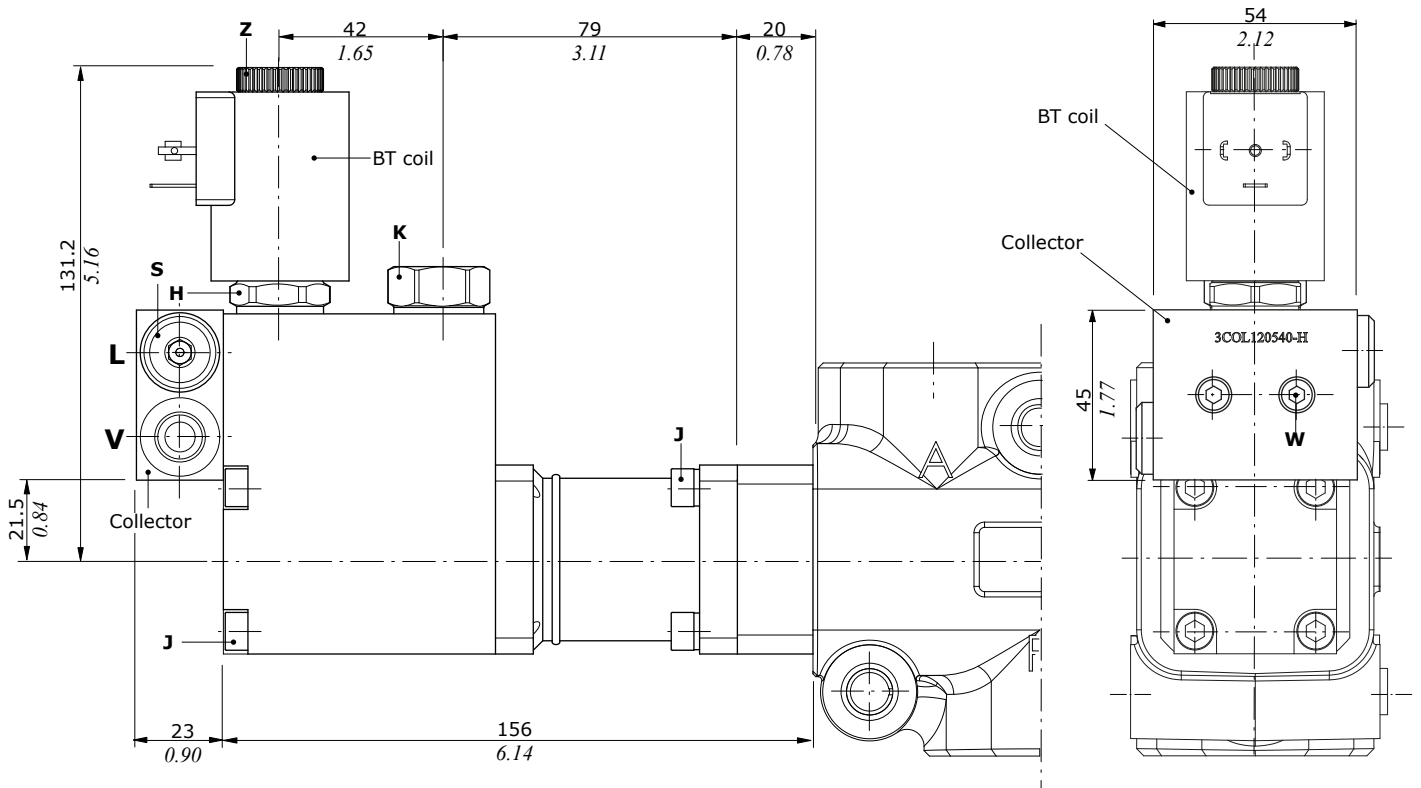
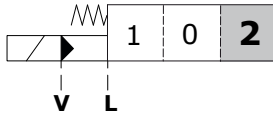

Collector kit for external pilot and drain

Wrenches and tightening torque

- J** = wrench 5 - 9.8 Nm (7.2 lbft)
 - K** = wrench 24 - 30 Nm (22.1 lbft)
 - Z** = 5 Nm (3.68 lbft)
 - S** = wrench 6 - 24 Nm (17.7 lbft)
 - H*** = wrench 24 - 9.8 Nm (7.2 lbft)
 - W** = wrench 4 - 6.6 Nm (4.9 lbft)
- (*)Tightening with dynamometric wrench or screwer

Features

- Pilot pressure: : min. 10 bar (145 psi)
- : max. 50 bar (725 psi)
- Max backpressure on drain L... : 25 bar (362.5 psi)

Note: for complete available BT coils list and features see page 64

COLLECTOR KIT CODE		
Type	Code	Description

KE1S0 5KE1S00070 kit for 1 section

Codes are referred to UN-UNF thread

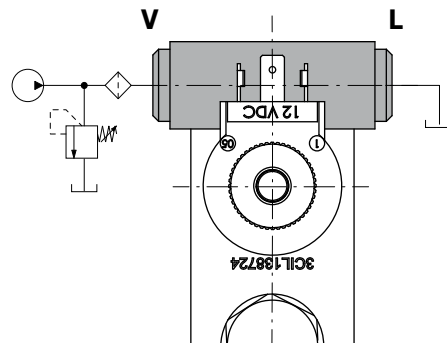

"B" side options

Lever control kit

Aluminium with protection boot lever pivot box; it can be rotated 180° (execution **L180**)

Type L

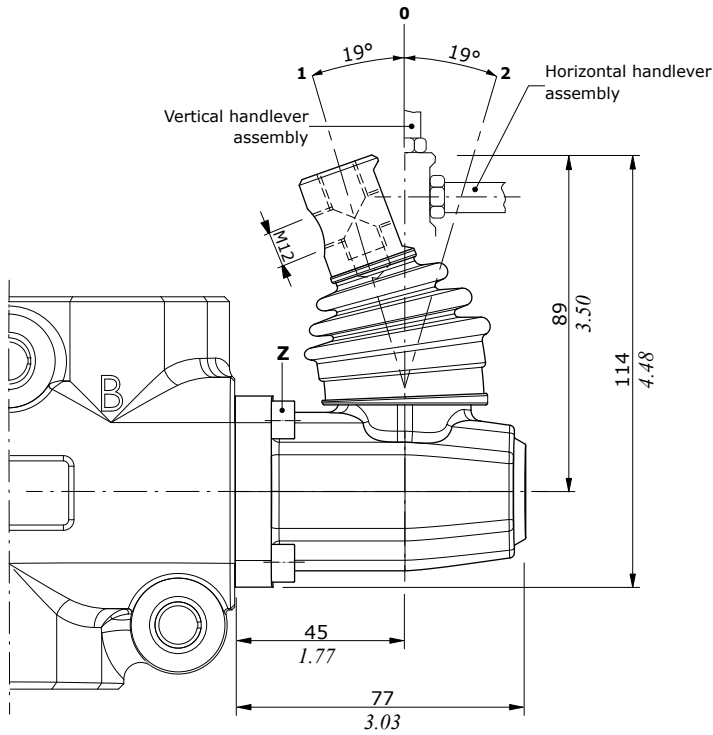
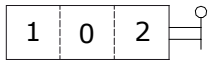

Cam control kit

Steel ball bearing cam operation (CA), and bronze cam operation (CB); it must be coupled to 17 control kit

Type CA-CB

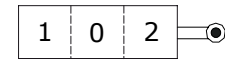

Wrenches and tightening torque

Z = wrench 5 - 9.8 Nm (7.2 lbft)

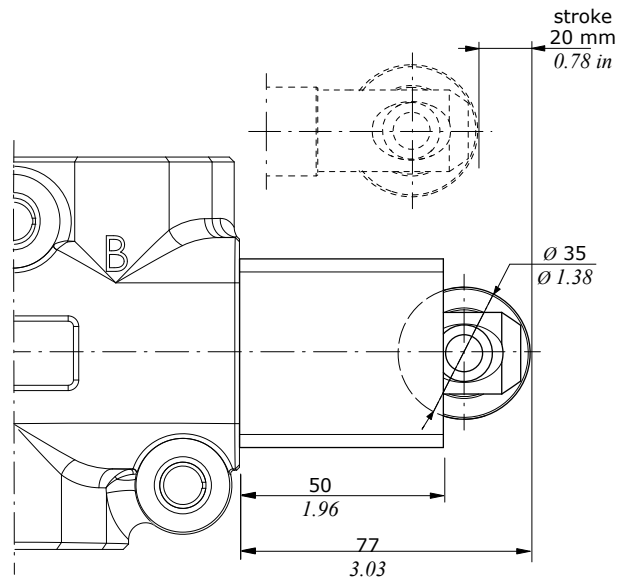

Without lever, with flange

Type SLP

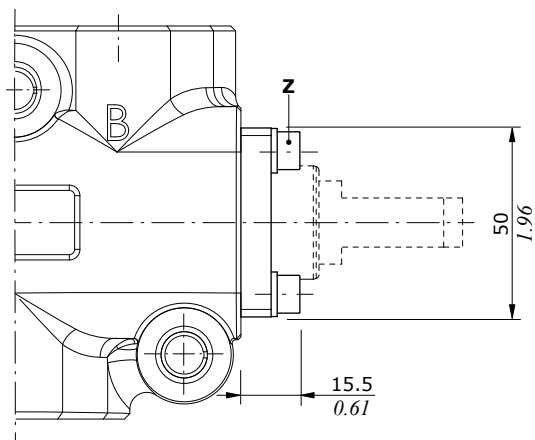
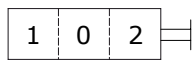

Without lever, with cap

Protection cap to use with pneumatic, hydraulic and electrohydraulic spool positioner kits

Type SLC

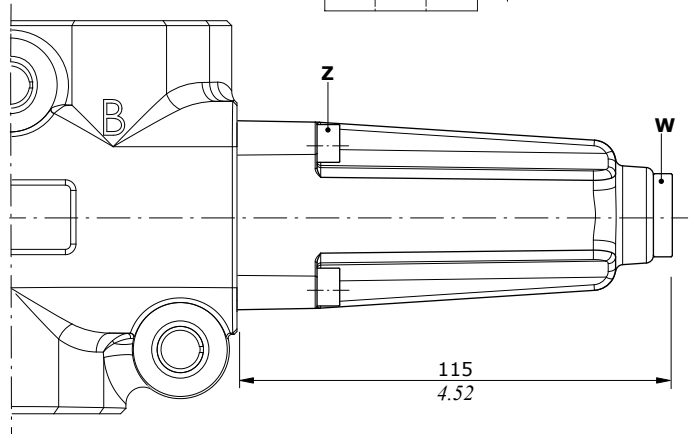
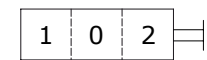

Wrenches and tightening torque

Z = wrench 5 - 9.8 Nm (7.2 lbft)

W = wrench 8 - 24 Nm (17.7 lbft)

Hydraulic controls

ON/OFF controls with high and low pressure pilot it must be only coupled to 17ME control kit

Type IA2
High pressure pilot

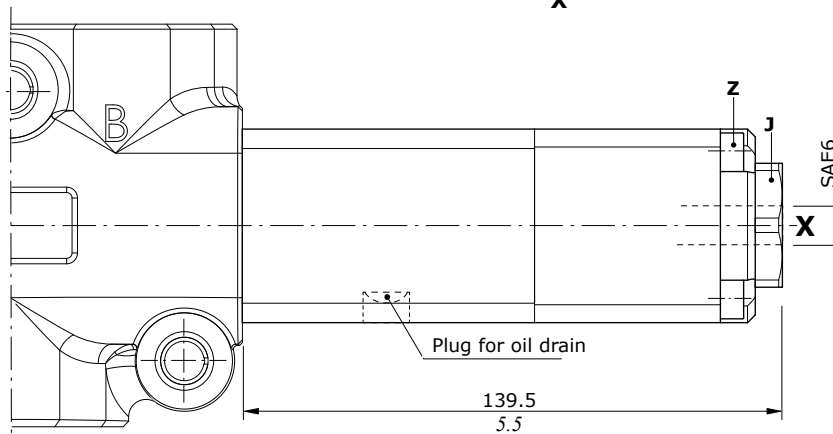
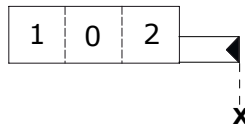

Pilot pressure... : min. 30 bar (435 psi) - max. 250 bar (3620 psi)

Wrenches and tightening torque

- Z = wrench 5 - 9.8 Nm (7.2 lbf ft)
- J = wrench 24 - 42 Nm (31 lbf ft)
- Q = wrench 6 - 24 Nm (17.7 lbf ft)

Type IB2
Low pressure pilot

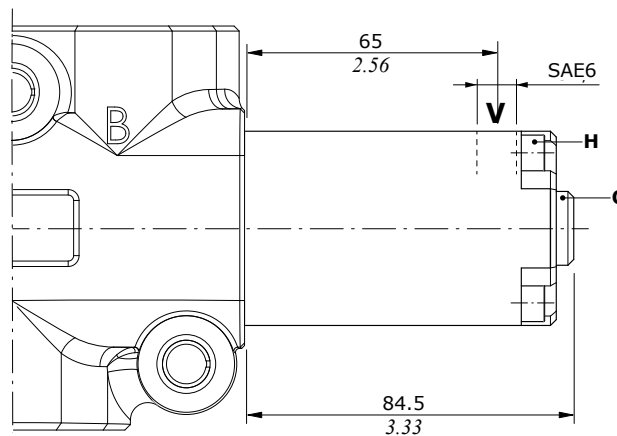
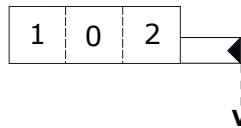

Pilot pressure... : min. 15 bar (217 psi) - max. 50 bar (725 psi)

Coils and accessories for 18EI1 control

Type	Voltage	Ordering codes					
		ISO4400	Deutsch DT	AMP JPT	Packard Weatherpack	Packard Metri-pack	Flying leads without connector
BT	10 VDC	4SL3000100	-	-	-	-	-
	12 VDC	4SL3000120	4SL3000130 ⁽⁶⁾	4SL3000122 ⁽⁵⁾	4SL3000124 ⁽²⁾	4SL3000127 ⁽²⁾	4SL300012C
		4SL3000126 ⁽⁴⁾	4SL3000134 ⁽³⁻⁶⁾	4SL3001200 ⁽³⁻⁵⁾	-	-	-
	24 VDC	4SL3000240	4SL3000249 ⁽⁶⁾	4SL3000248 ⁽⁵⁾	-	-	4SL3000246
		4SL3030240 ⁽¹⁾	4SL300024C ⁽³⁻⁶⁾	-	-	-	-
	26 VDC	4SL3000260	-	-	-	-	-
	48 VDC	4SL3000480	-	-	-	-	-
		4SL3030480 ⁽¹⁾	-	-	-	-	-
110 VDC	4SL3001100	-	-	-	-	-	
220 VDC	4SL3031100 ⁽¹⁾	-	-	-	-	-	
	220 VDC	4SLE022000A	-	-	-	-	
		4SLE322000A ⁽¹⁾	-	-	-	-	
Mating connectors							
		4CN1009995	5CON140031	5CON003	5CON001	5CON017	-
With rectifier	24 VDC	4CN3010240	-	-	-	-	-
	48 VDC	4CN3010480	-	-	-	-	-
	110 VDC	4CN3011100	-	-	-	-	-
	220 VDC	4CN3012200	-	-	-	-	-

Notes: ⁽¹⁾ supply with AC and use only with rectifier connector - ⁽²⁾ with flying leads - ⁽³⁾ with bidirectional diode - ⁽⁴⁾ with unidirectional diode - ⁽⁵⁾ integrated perpendicular type - ⁽⁶⁾ integrated parallel type

Features

Nominal voltage tolerance: ±10%

Nominal power..... : 19 W - 10 VDC
 : 21 W - 12/24/26 VDC
 : 20.3 W - 48 VDC
 : 17.3 W - 110 VDC
 : 17.7 W - 220 VDC

Nominal current..... : 1.9 A @ 10 VDC
 : 1.77 A @ 12 VDC
 : 0.89 A @ 24VDC
 : 0.84 A @ 26 VDC
 : 0.43 A @ 48 VDC
 : 0.16 A @ 110 VDC
 : 0.08 A @ 220 VDC

Insulation..... : Class F (155°C - 311°F)

Weather protection... : IP65 - ISO4400 / AMP JPT

: IP69K - Deutsch DT

: IP67 - Weatherpack / Metri-pack

Insertion..... : 100%

ISO4400 connector

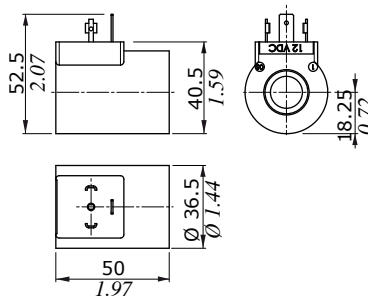

DEUTSCH DT04 connector

(Parallel type)

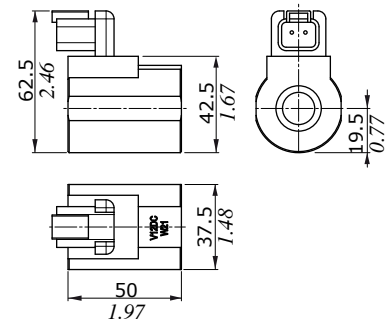

Flying leads

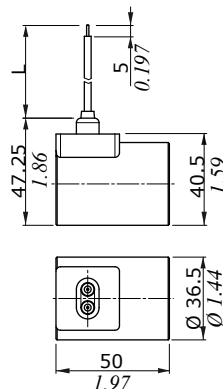

AMP JPT connector

(Perpendicular type)

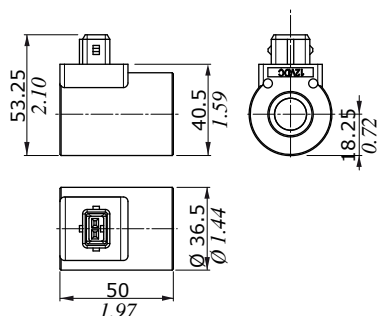

Coil type	L dimension	
	(mm)	(in)
12 VDC	240	9.45
24 VDC	600	23.62

Coils and accessories for 18E11 control

Flying leads with DEUTSCH DT04 connector

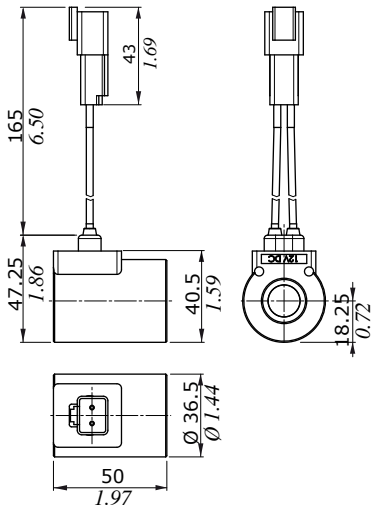

Flying leads with PACKARD METRI-PACK connector

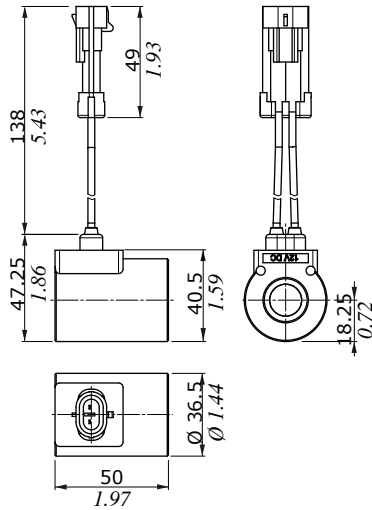

Flying leads with PACKARD WEATHER-PACK connector

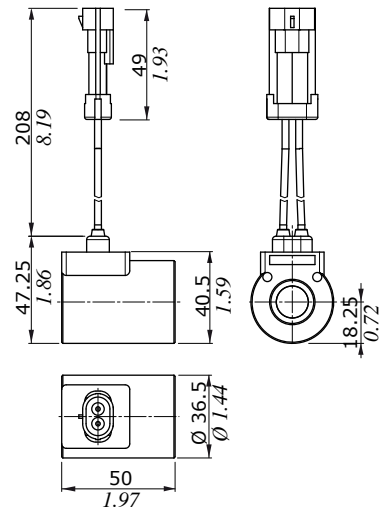



DF250

Hydraulic control monoblock diverter valve

- 6 ways configuration
- Ports with SAE flange connection
- Hydraulic controls

This catalogue shows technical specifications and diagrams measured with mineral oil of 46 mm²/s (46 cSt) viscosity at 40°C - (104°F) temperature.

WORKING CONDITIONS		
N. of available ways		6
Max. flow rating		250 l/min (66 US gpm)
Max. pressure		350 bar (5100 psi)
Internal leakage A(B)⇒T	$\Delta p = 100 \text{ bar (1450 psi)}$	8 ÷ 12 cm ³ /min (0.48 ÷ 0.73 in ³ /min)
Fluid		Mineral based oil
Fluid temperature	with NBR (BUNA-N) seals	from -20°C to 80°C (from -4°F to 176°F)
	with FPM (VITON) seals	from -20°C to 100°C (from -4°F to 212°F)
Viscosity	operating range	from 10 to 300 mm ² /s (from 10 to 300 cSt)
Max. level of contamination		20/18/15 - ISO 4406 - NAS 1638 - class 9
Ambient temperature for working conditions		from -40°C to 60°C (from -40°F to 140°F)

NOTE - For different working conditions please contact Sales Dept.

Available threads

FLANGE CONNECTION (ASSEMBLING SCREW)		
Type	ISO6162-2 / SAE J518-2 (Codice 62) Tipo 1	SAE J518-2 (Codice 62) Tipo 2
DF250	DN25 (M12) 1" (M12)	1" (7/16-14 UNC)

Dimensional data - hydraulic circuit - performance data

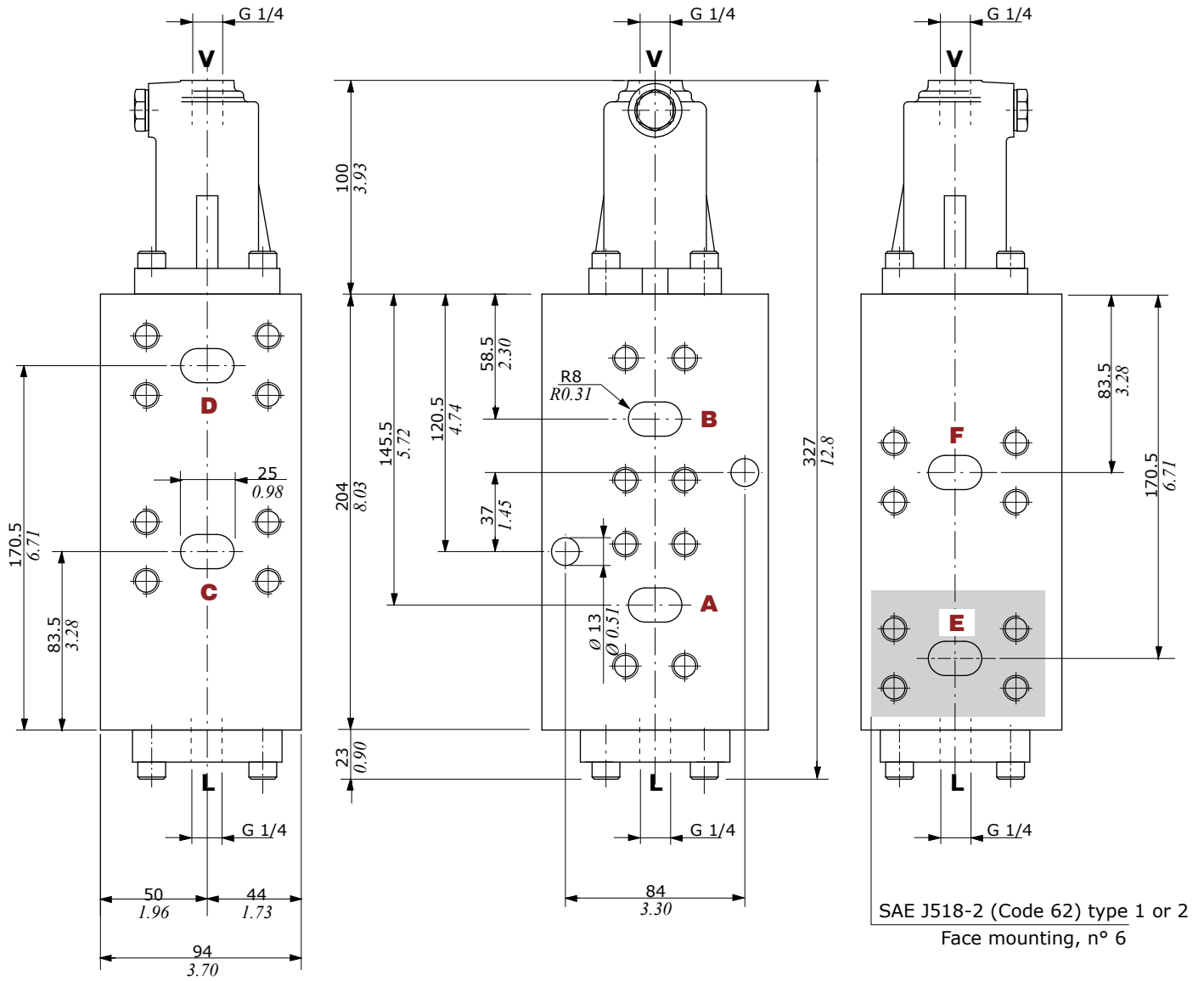

Pressure drop versus flow

P → A(B)

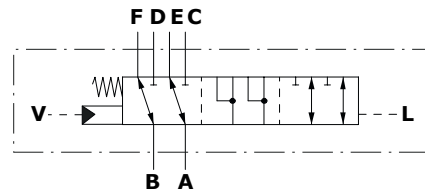
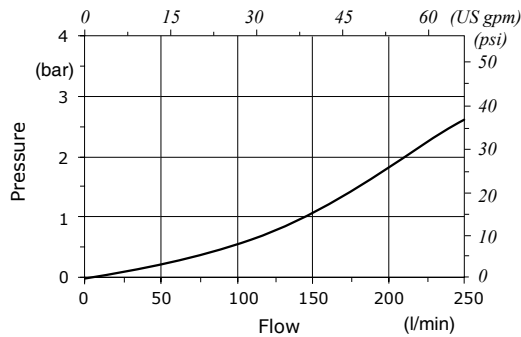

Example:

DF250 / W025A - H005 - DB S35 - P006 N10
 1 2 3 1 1 Painted with one layer of black Primer antirust

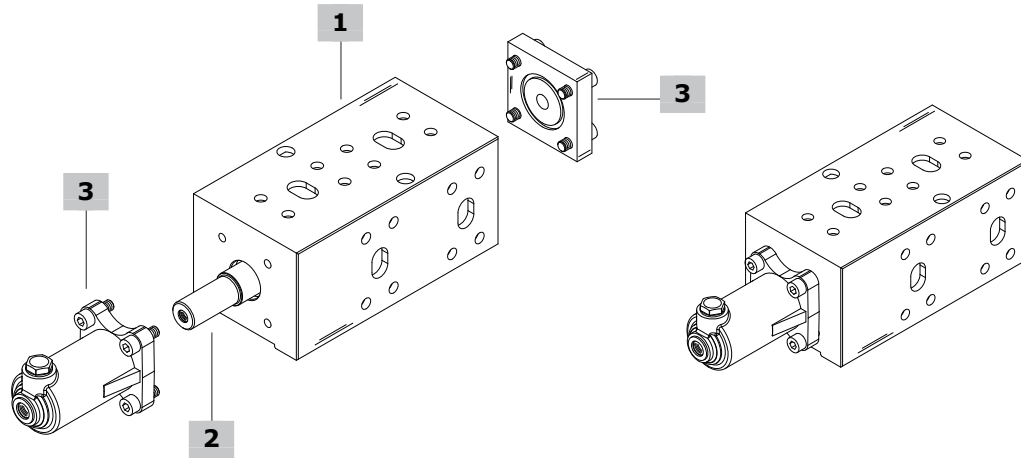

1 Body kit

TYPE: **DF250-DB-S35** CODE: 430035002
 DESCRIPTION: 6 ways body kit, DN25/1", ISO6162-2 / SAE J518-2 (Code 62) Type 1 flange
 TYPE: **DF250-DB-S36** CODE: 430035003
 DESCRIPTION: 6 ways body kit, DN25/1", SAE J518 (Code 62) Type 2 flange

3 Complete controls

TYPE	CODE	DESCRIPTION
H005	320535001	Hydraulic control, with G1/4 port
	430035001	Flange kit for hydraulic control, with G1/4 port

2 Spools **pag. 69**

TYPE	CODE	DESCRIPTION
W025A	421235002	Flow in E and F. C and D closed in pos. 1 Ports connected in transit position
W026A	421235001	Flow in E and F. C and D closed in pos. 1 Ports closed in transit position

Spool circuits

Type W025A

Flow in E and F. C and D closed in pos. 1
Ports connected in transit position

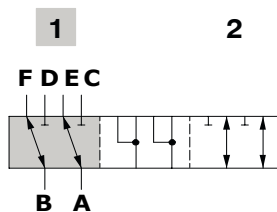

Spool stroke
Position 2: + 10 mm (0.39 in)

Type W026A

Flow in E and F. C and D closed in pos. 1
Ports closed in transit position

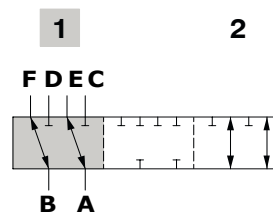

Spool stroke
Position 2: + 10 mm (0.39 in)



DF350

Hydraulic control monoblock diverter valve

- 6 ways configuration
- Ports with SAE flange connection
- Hydraulic controls

This catalogue shows technical specifications and diagrams measured with mineral oil of 46 mm²/s (46 cSt) viscosity at 40°C - (104°F) temperature.

WORKING CONDITIONS		
N. of available ways		6
Max. flow rating		350 l/min (92.4 US gpm)
Max. pressure		350 bar (5100 psi)
Internal leakage A(B)⇒T	Δp = 100 bar (1450 psi)	8 ÷ 12 cm ³ /min (0.48 ÷ 0.73 in ³ /min)
Fluid		Mineral based oil
Fluid temperature	with NBR (BUNA-N) seals	from -20°C to 80°C (from -4°F to 176°F)
	with FPM (VITON) seals	from -20°C to 100°C (from -4°F to 212°F)
Viscosity	operating range	from 10 to 300 mm ² /s (from 10 to 300 cSt)
Max. level of contamination		20/18/15 - ISO 4406 - NAS 1638 - class 9
Ambient temperature for working conditions		from -40°C to 60°C (from -40°F to 140°F)

NOTE - For different working conditions please contact Sales Dept.

Available threads

FLANGE CONNECTION (ASSEMBLING SCREW)		
Type	ISO6162-2 / SAE J518-2 (Code 62) Type 1	SAE J518-2 (Code 62) Type 2
DF350	DN32 (M12) 1" 1/4 (M12)	1" 1/4 (1/2-13 UNC)

Dimensional data - hydraulic circuit - performance data

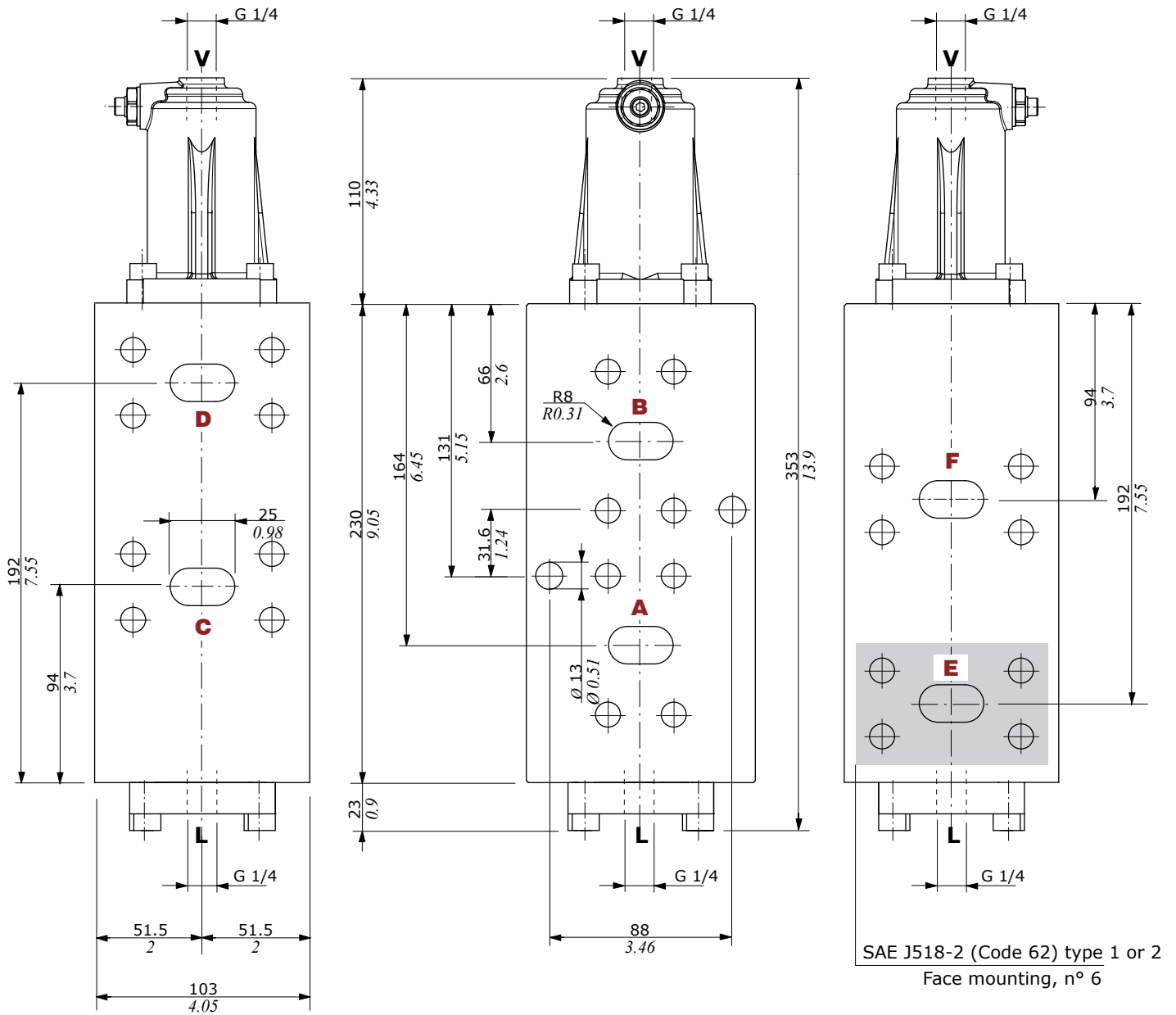

Pressure drop versus flow

P → A(B)

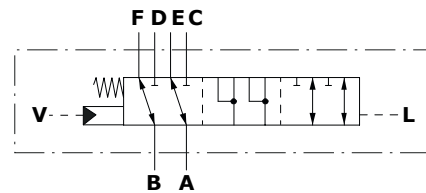
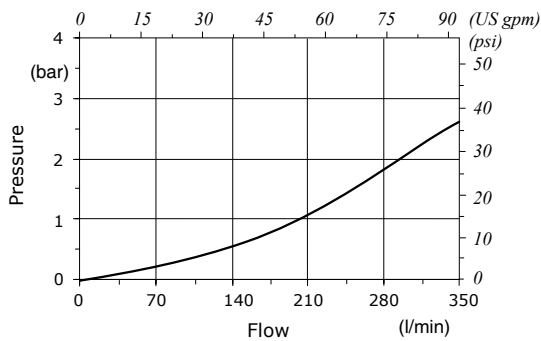

Example:

DF350 / W025A - H005 - DB S37 - P006 N10
 Painted with one layer of black Primer antirust

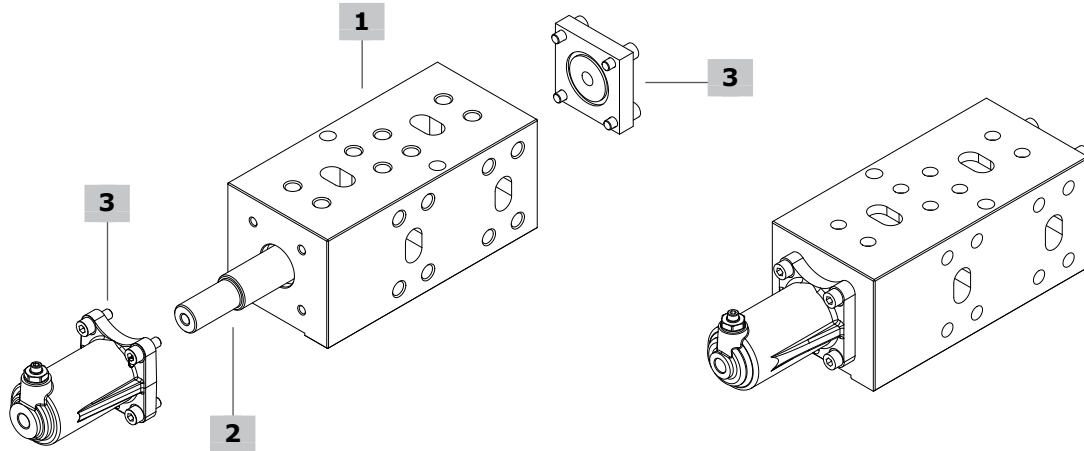

1 Body kit

TYPE: **DF350-DB-S37** CODE: 430036002
 DESCRIPTION: 6 ways body kit, DN32/1" 1/4, ISO6162-2 / SAE J518-2 (Code 62) Type 1 flange
 TYPE: **DF350-DB-S38** CODE: 430036003
 DESCRIPTION: 6 ways body kit, DN32/1" 1/4, SAE J518 (Code 62) Type 2 flange

3 Complete controls

TYPE	CODE	DESCRIPTION
H005	320536002	Hydraulic control, with G1/4 port
	430036001	Flange kit for hydraulic control, with G1/4 port

2 Spools **page 73**

TYPE	CODE	DESCRIPTION
W025A	421236002	Flow in E and F. C and D closed in pos. 1 Ports connected in transit position
W026A	421236001	Flow in E and F. C and D closed in pos. 1 Ports closed in transit position

Spool circuits

Type W025A

Flow in E and F. C and D closed in pos. 1
Ports connected in transit position

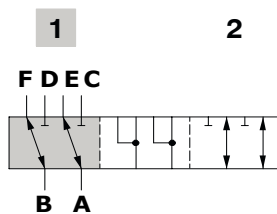

Spool stroke
 Position 2: + 13 mm (0.51 in)

Type W026A

Flow in E and F. C and D closed in pos. 1
Ports closed in transit position

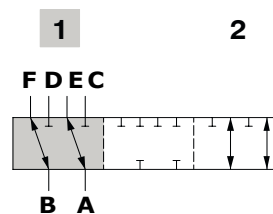

Spool stroke
 Position 2: + 13 mm (0.51 in)



DFE052

Solenoid control monoblock diverter valves

- 2 - 3 - 6 - 8 ways configuration
- Galvanized body

This catalogue shows technical specifications and diagrams measured with mineral oil of 46 mm²/s (46 cSt) viscosity at 40°C - (104°F) temperature.

WORKING CONDITIONS		
N. of available ways		2 - 3 - 6 - 8
Max. flow rating		60 l/min (15.8 US gpm)
Max. pressure	without drain	200 bar (2900 psi)
	with drain	315 bar (4600 psi)
Available supply voltage	VDC	see reference page 85
Nominal power		38 W
Internal leakage A(B)⇒T	Δp = 100 bar (1450 psi)	7 cm ³ /min (0.42 in ³ /min)
Fluid		Mineral based oil
Fluid temperature	with NBR (BUNA-N) seals	from -20°C to 80°C (from -4°F to 176°F)
	with FPM (VITON) seals	from -20°C to 100°C (from -4°F to 212°F)
Viscosity	operating range	from 15 to 75 mm ² /s (from 15 to 75 cSt)
	min.	12 mm ² /s (12 cSt)
	max.	400 mm ² /s (400 cSt)
Max. level of contamination		20/18/15 - ISO 4406 - NAS 1638 - class 9
Ambient temperature for working conditions		from -20°C to 50°C (from -4°F to 122°F)

NOTE - For different working conditions please contact Sales Dept.

Available threads

PORTS THREAD			
ALL PORTS	BSP	UN-UNF	METRIC* (ISO 9974-1)
DFE052	G 3/8	3/4-16 (SAE 8)	M18x1.5
PILOT PORTS			
L	G 1/4	9/16-18 (SAE 6) 7/16-20 (SAE 4)**	M12x1.5

(**): for DFE052/8 diverter valves

(*): Optional threads
for availability contact Sales
Department

Dimensional data - hydraulic circuit - performance data

2 ways

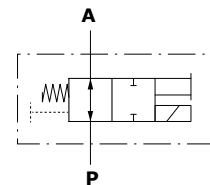
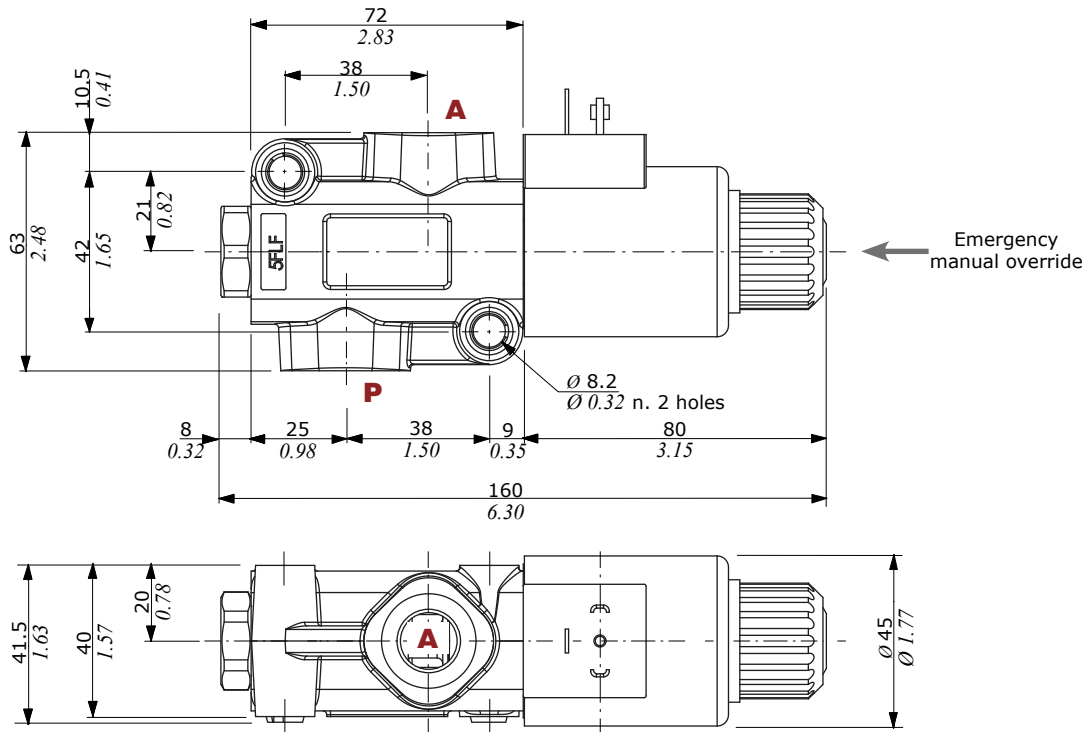

Pressure drop versus flow

P → A

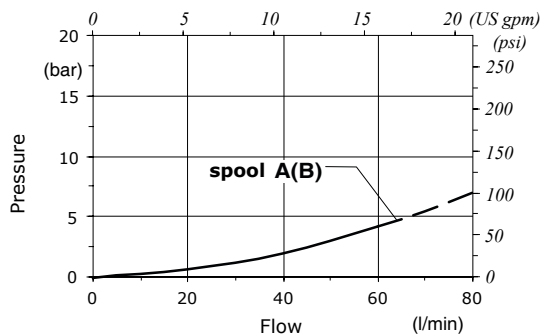

Minimum dynamic conditions

(Supply = Vn-10%, coil at 70 °C - 158 °F)

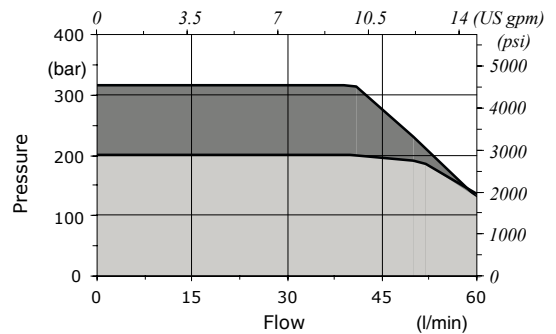

■ With drain
■ Without drain

Dimensional data - hydraulic circuit - performance data

3 ways

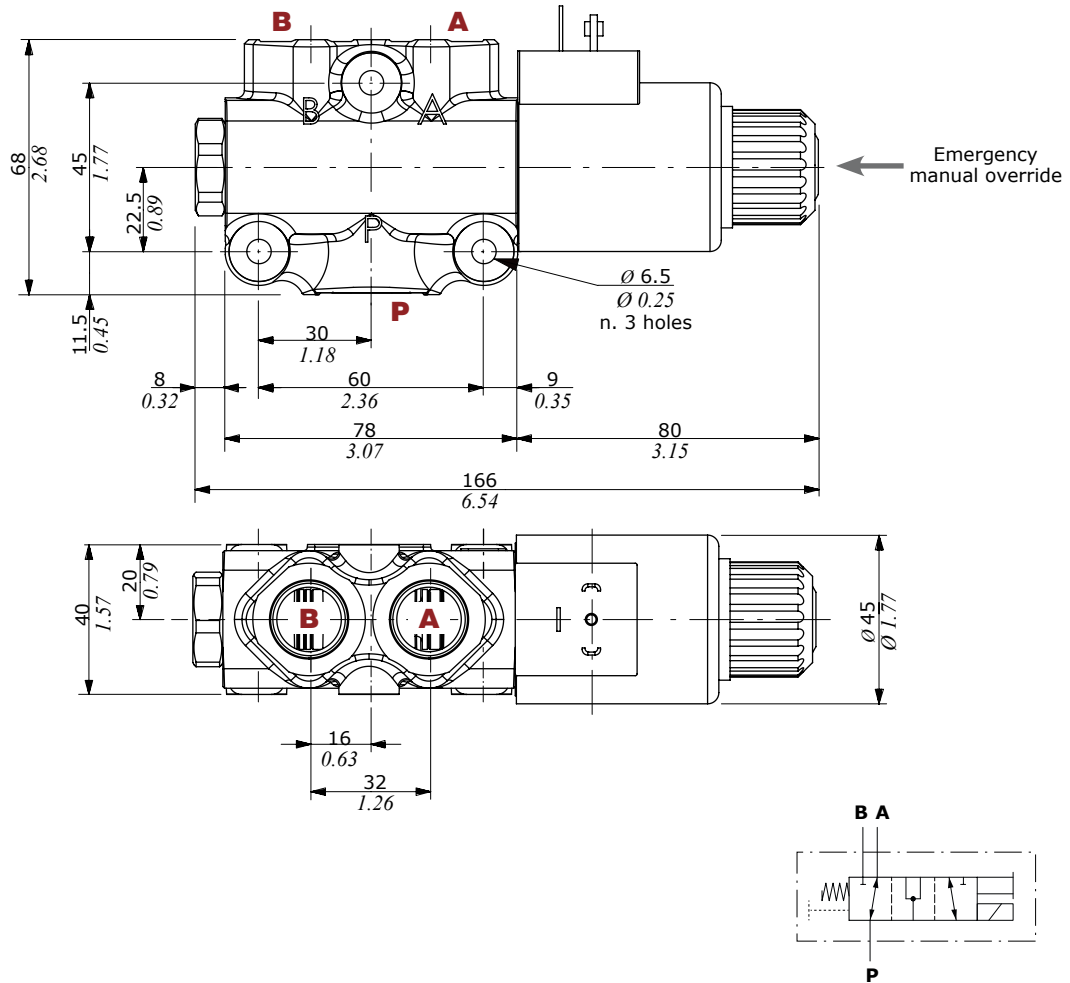

Pressure drop versus flow

P → A(B)

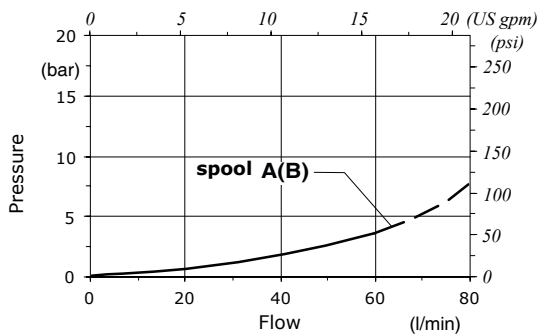

Minimum dynamic conditions

(Supply = Vn-10%, coil at 70 °C - 158 °F)

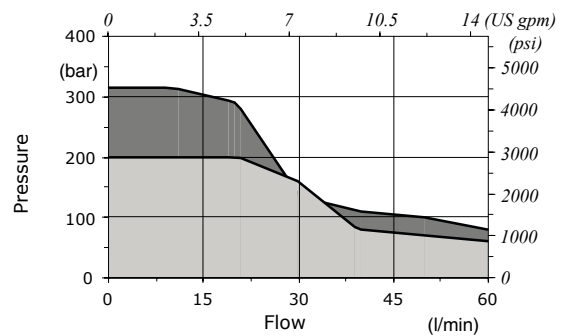

■ With drain
■ Without drain

Dimensional data - hydraulic circuit - performance data

6 ways

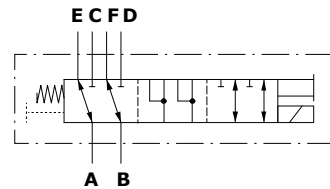
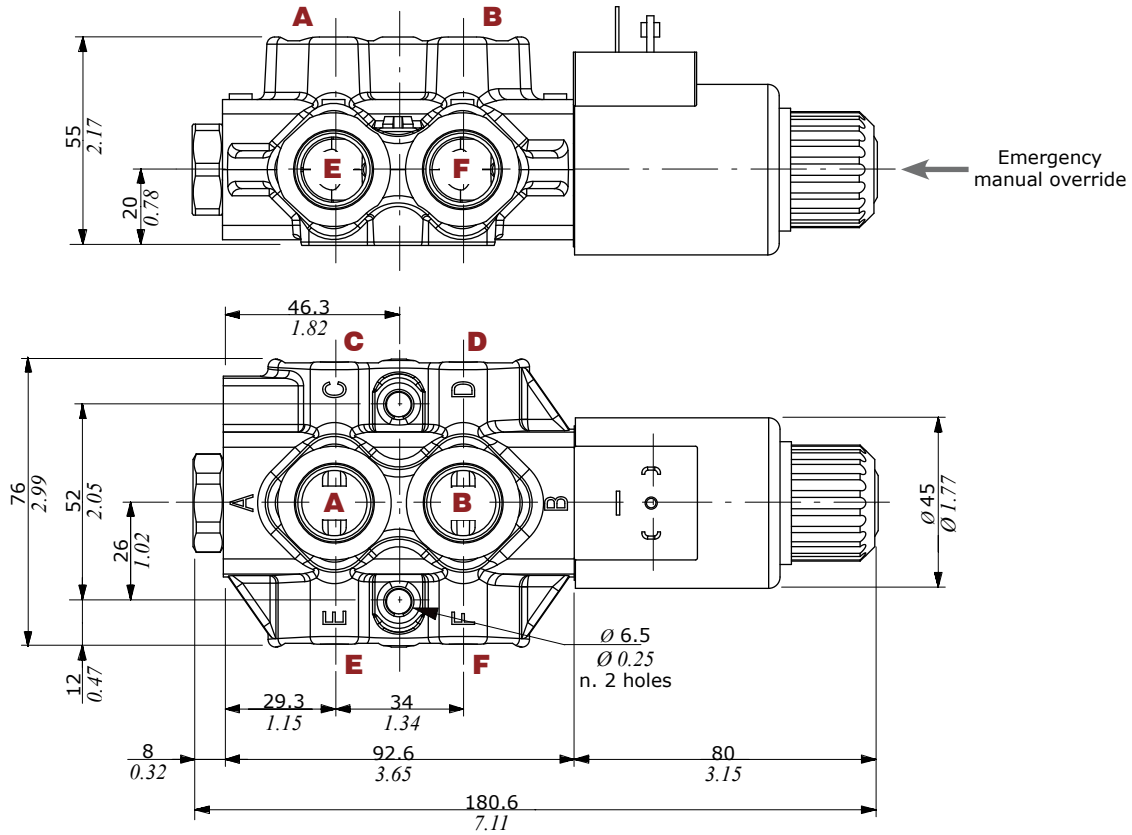

Pressure drop versus flow

A → C(E)

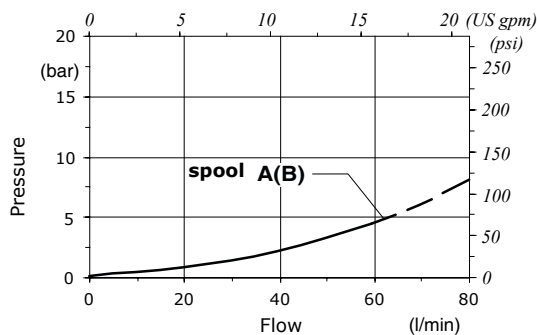

Minimum dynamic conditions

(Supply = Vn-10%, coil at 70 °C - 158 °F)

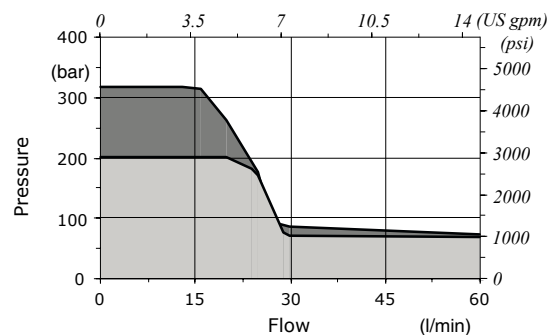

■ With drain
■ Without drain

Dimensional data - hydraulic circuit - performance data

8 ways

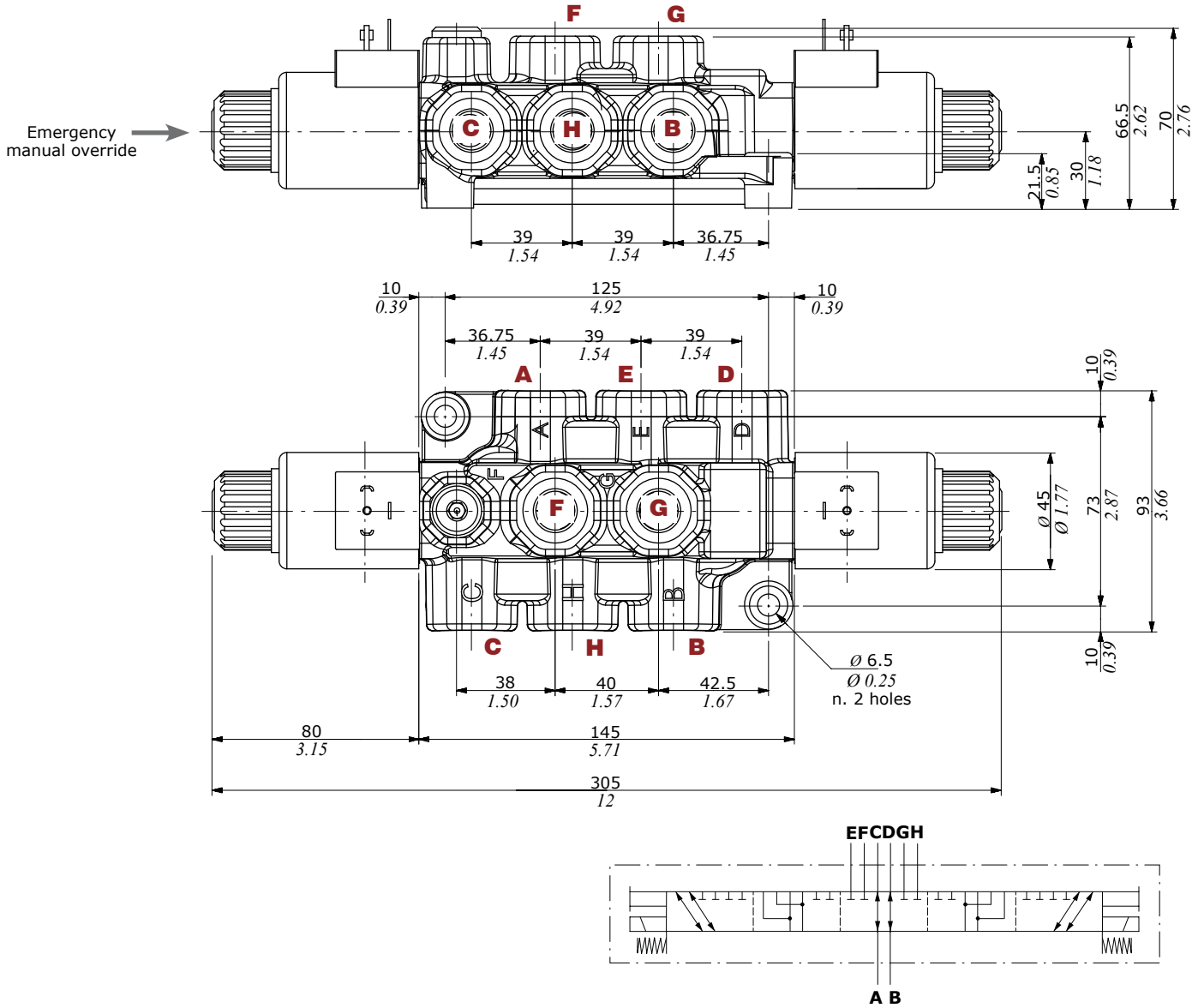

Pressure drop versus flow

A → C

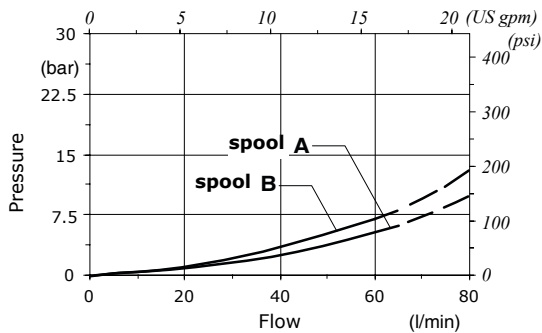

Minimum dynamic conditions

(Supply = Vn-10%, coil at 70 °C - 158 °F)

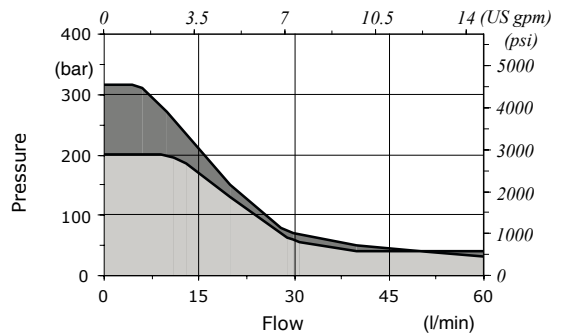

■ With drain
■ Without drain

Part ordering codes

Example:

For description composition see the text below

DFE052/3 A 18 ES - W 2 0 2 - 12VDC - SAE - (CRZ)

1 2 3 4 3 4 5 6 Galvanized body

... 2 0 (300) DB 2 - 12VDC - ...

Coil
1 = without coil
2 = with coil

Connection*
0 = ISO (Std)
2 = AMP-JPT
3 = Deutsch DT06
4 = Deutsch DT04-2P Male
5 = Deutsch DT04-4P Female
6 = Metri-Pack Female
7 = Metri-Pack Male
8 = WeatherPack Male
9 = WeatherPack Female

Diode*
(text omitted if diode is not present)
DB = bidirectional diode

Bellow
1 = without bellow
2 = with bellow

Lenght cables
(only if it's present)
Lenght is in mm

Coil voltage

(*) - For diodes and connector options see coils table on page 85

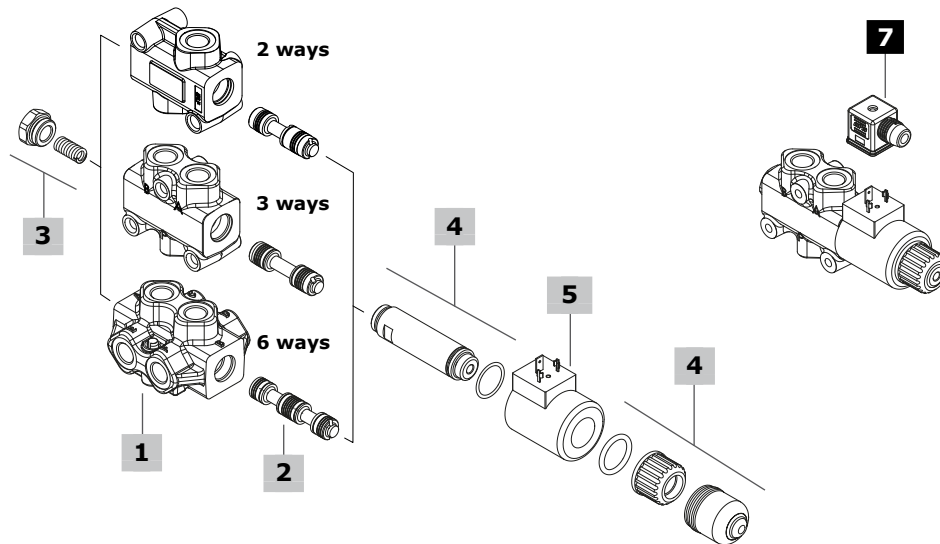

1 Body kit*			3 Positioner kit page 83		
TYPE	CODE	DESCRIPTION	TYPE	CODE	DESCRIPTION
DFE052/2	3CO2220721	2 ways body kit	18...W	5TAP001	Spring return in pos. 1
DFE052/3	3CO2221725	3 ways body kit	18...Y	5GIU003*	Spring return in pos. 1, with SAE6 drain port
DFE052/6	3CO2222725	Standard body kit			

2 Spools page 82			4 Solenoid kit page 84		
TYPE	CODE	DESCRIPTION	TYPE	CODE	DESCRIPTION
for DFE052/2:			ES	5SOL515000	Tube assembly without protective bellow
A	3CAS105245	Open port in neutral	-	4ACC515	Optional tube assembly protective bellow
B	3CAS105145	Closed port in neutral			
for DFE052/3:					
A	3CAS105345	Flow in A in neutral. Ports connected in transit position			
B	3CAS105445	Flow in A in neutral. Ports closed in transit position			
D	3CAS105546	Closed ports in neutral and connected in transit position			
for DFE052/6:					
A	3CAS105645	Flow in E and F. C and D closed in pos. 1. Ports connected in transit position			
B	3CAS105746	Flow in E and F. C and D closed in pos. 1. Ports closed in transit position			
H	3CAS105845	D<->C in pos. 1, F<->E in pos. 2. Ports closed in transit position			

(*) - Codes are referred to **UN-UNF** thread

Part ordering codes

For description composition
see the text on previous page

DFE052/8 **B** **8** **ES3** - **W** **2 0 2** - **12VDC** - **SAE** - **(CRZ)**

1 2 3 4 5 4 6 7 Galvanized body

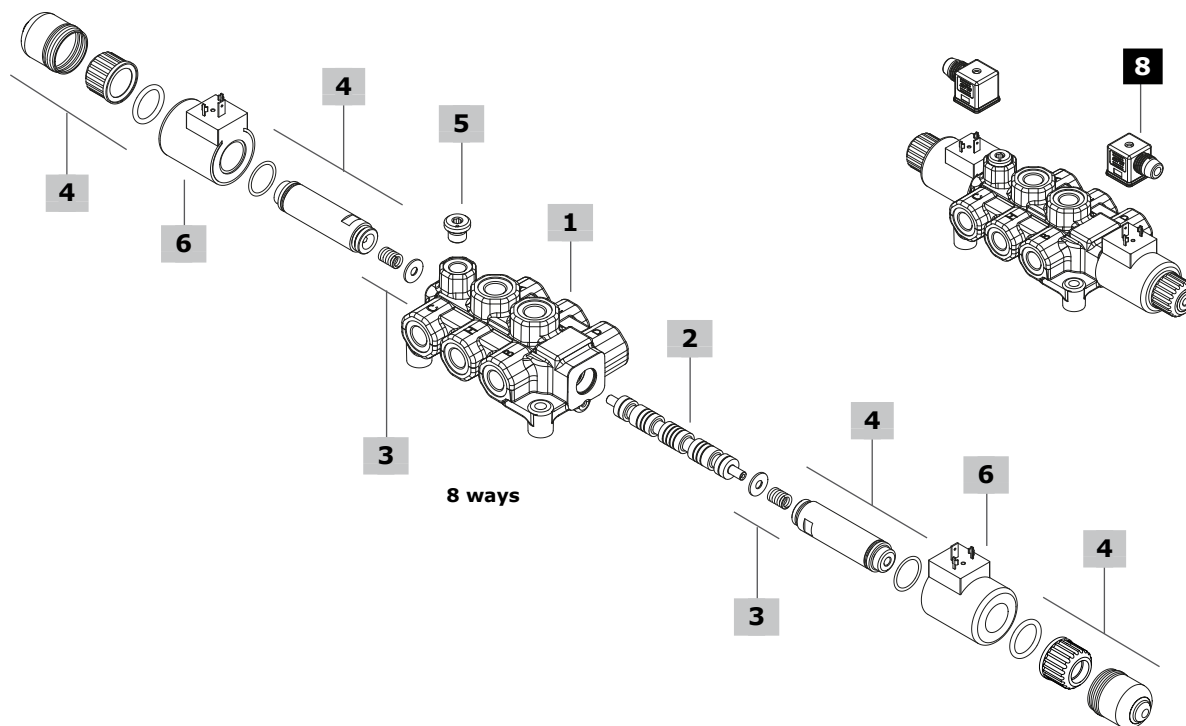

1 Body kit*

TYPE	CODE	DESCRIPTION
DFE052/8	3CO2224750MZ	8 ways body kit

2 Spools **page 83**

TYPE	CODE	DESCRIPTION
A	3CAS105A70M	Flow in C and D. E, F, G and H closed in pos. 0. Ports connected in transit position
B	3CAS105B70M	Flow in C and D. E, F, G and H closed in pos. 0. Ports closed in transit position
I	3CAS105I70M	Flow in C and D. E, F, G and H closed in pos. 0.

3 Positioner kit **page 84**

TYPE	CODE	DESCRIPTION
8 (ES)	5V080528	Spring return in pos. 0

4 Solenoid kit **page 84**

TYPE	CODE	DESCRIPTION
ES	5SOL515000	Tube assembly without protective bellow
-	4ACC515	Optional tube assembly protective bellow

5 Drain* **page 84**

TYPE	CODE	DESCRIPTION
W	3XTAP814120	Without drain, with plug SAE4
Y	-	With SAE4 drain port

6 Coil

For list of available coils see pages 85

7 Body threading

Specify threading always when it is different from **BSP** standard

8 Accessories

For list of available connectors see pages 85

(*) - Codes are referred to **UN-UNF** thread

Spool circuits

2 ways

Type A Open port in neutral position **Type B** Closed port in neutral position

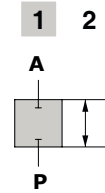
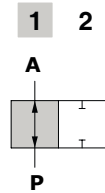

Spool stroke Position 2: - 4 mm (- 0.15 in) **Spool stroke** Position 2: - 4 mm (- 0.15 in)

3 ways

Type A
Ports connected in transit position

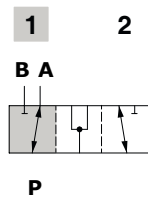

Spool stroke Position 2: - 4 mm (- 0.15 in)

Type B
Ports closed in transit position

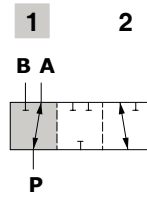

Spool stroke Position 2: - 4 mm (- 0.15 in)

Type D
Closed ports in neutral and connected in transit position

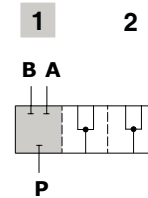

Spool stroke Position 2: - 4 mm (- 0.15 in)

6 ways

Type A
Flow in E and F. C and D closed in pos. 1
Ports connected in transit position

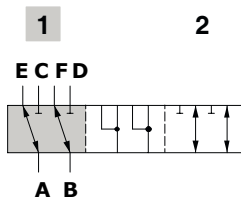

Spool stroke Position 2: - 4 mm (- 0.15 in)

Type B
Flow in E and F. C and D closed in pos. 1
Ports closed in transit position

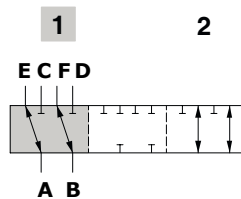

Spool stroke Position 2: - 4 mm (- 0.15 in)

Type H
D<->C in pos. 1, F<->E in pos. 2
Ports closed in transit position

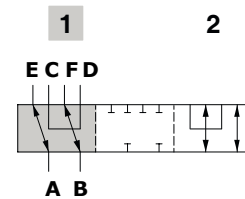

Spool stroke Position 2: - 4 mm (- 0.15 in)

Spool circuits

8 ways

Type A

Flow in C and D. E, F, G and H closed in pos. 0. Ports connected in transit position

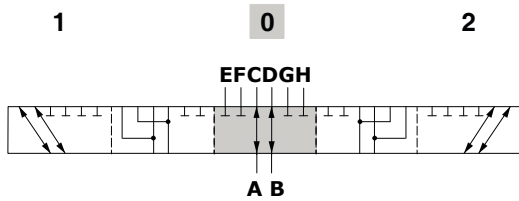

Spool stroke

Position 1: + 3.4 mm (0.13 in)
Position 2: - 3.4 mm (-0.13 in)

Type B

Flow in C and D. E, F, G and H closed in pos. 0. Ports closed in transit position

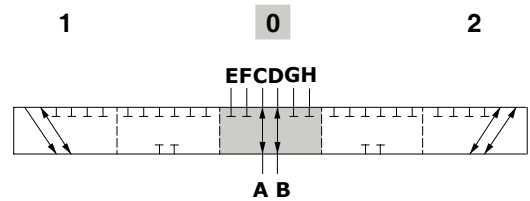

Spool stroke

Position 1: + 3.4 mm (0.13 in)
Position 2: - 3.4 mm (-0.13 in)

Type I

Flow in C and D. E, F, G and H closed in pos. 0.

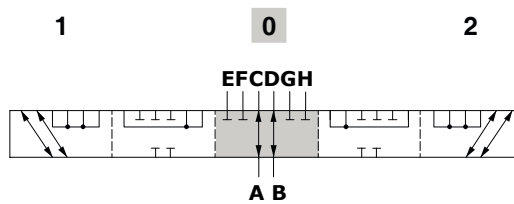

Spool stroke

Position 1: + 3.4 mm (0.13 in)
Position 2: - 3.4 mm (-0.13 in)

Positioner kit

With spring return in position 1

Type 18W

With plug

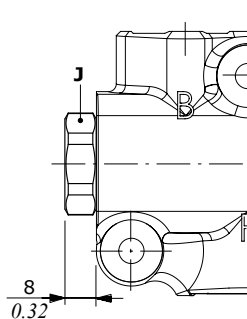

Type 18Y

With SAE6 drain port

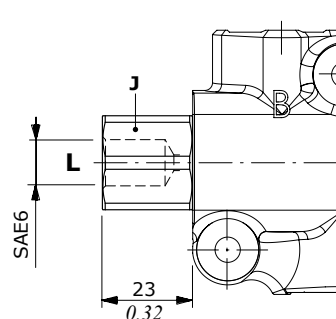
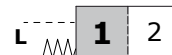

Wrenches and tightening torque

J = wrench 24 - 24 Nm (17.7 lbft)

Solenoid kit

ES tube assembly kit

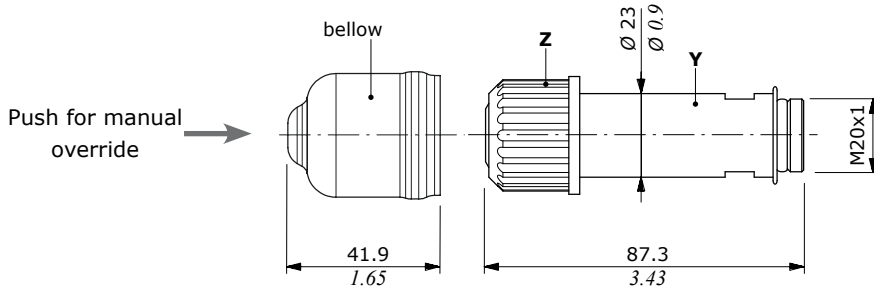

Wrenches and tightening torque
Y = wrench 20 - 20 Nm (14.7 lbf)
Z = 24 Nm (17.7 lbf)

Positioner kit and solenoid kit - DFE052/8

With spring return in position 0

Tipo 8ES3

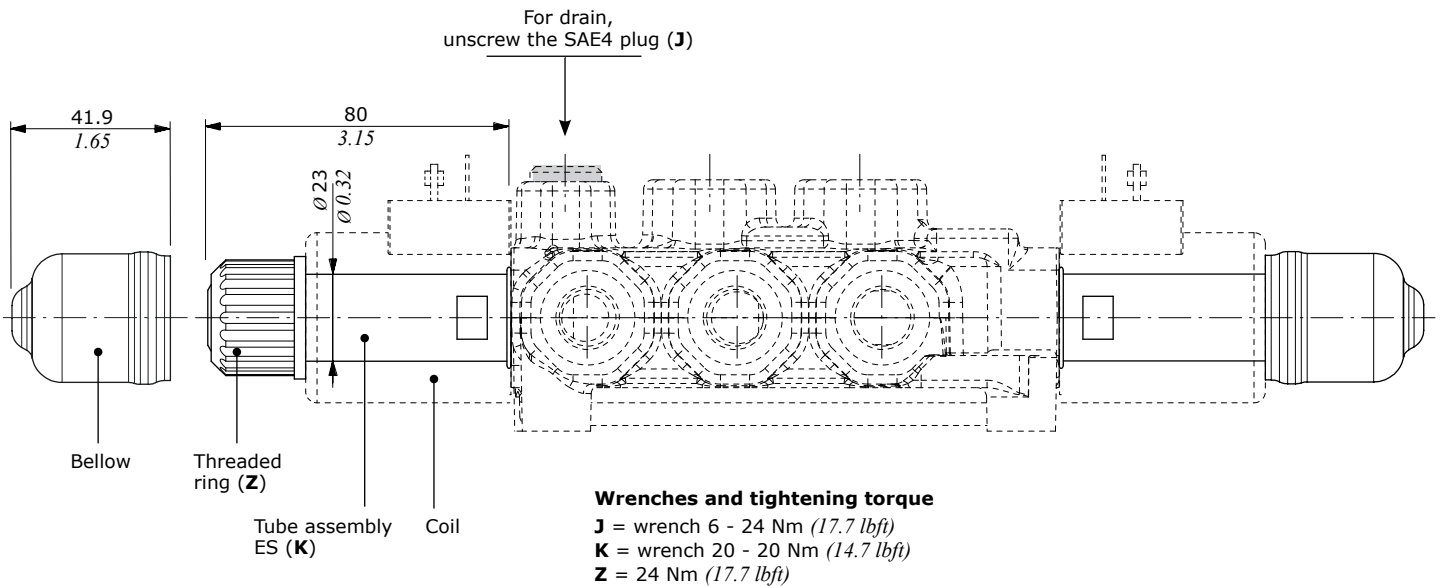
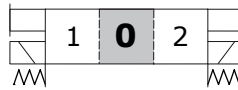

Wrenches and tightening torque
J = wrench 6 - 24 Nm (17.7 lbf)
K = wrench 20 - 20 Nm (14.7 lbf)
Z = 24 Nm (17.7 lbf)

Coils and accessories

Type	Voltage	Ordering codes					Flying leads without connector
		Connector types					
		ISO4400	Deutsch DT	AMP JPT	Packard Weatherpack	Packard Metri-pack	
D15	12 VDC	4SOL515012	4SOL515011 ⁽²⁾ 4SOL515014A ⁽³⁻⁶⁾	4SOL515016 ⁽⁵⁾	-	-	-
	14 VDC	-	4SOL515014B ⁽³⁻⁶⁾	4SOL515016A ⁽⁵⁾	-	-	-
	24 VDC	4SOL515024	4SOL515025A ⁽³⁻⁶⁾ 4SOL515021 ⁽²⁾	-	-	-	-
	48 VDC	4SOL515048	-	4SOL515049 ⁽²⁾	-	-	-
	98 VDC	4SOL515098	-	-	-	-	-
	110 VDC	4SOL515110	-	-	-	-	-
Mating connectors							
		4CN1009995	5CON140031	5CON003	-	-	-

Notes: (1) supply with AC and use only with rectifier connector - (2) with flying leads - (3) with bidirectional diode - (4) with unidirectional diode (5) integrated perpendicular type - (6) integrated parallel type

Features

- Nominal voltage tolerance: ±10%
- Nominal power.....: 38 W
12/14/24/48/98/110 VDC
- Nominal current..... : 3.16 A @ 12 VDC
: 2.9 A @ 14 VDC
: 1.58 A @ 24 VDC
: 0.79 A @ 48 VDC
: 0.41 A @ 98 VDC
: 0.35 A @ 110 VDC
- Insulation.....: Class H (180°C - 356°F)
- Weather protection.....: IP65 - ISO4400
: IP69K - Deutsch DT
: IP65 - AMP JPT
- Insertion.....: 100%

ISO4400 connector

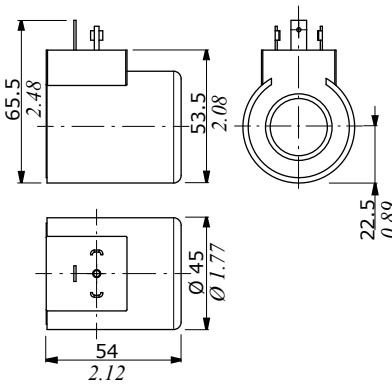

Flying leads with DEUTSCH DT04 connector

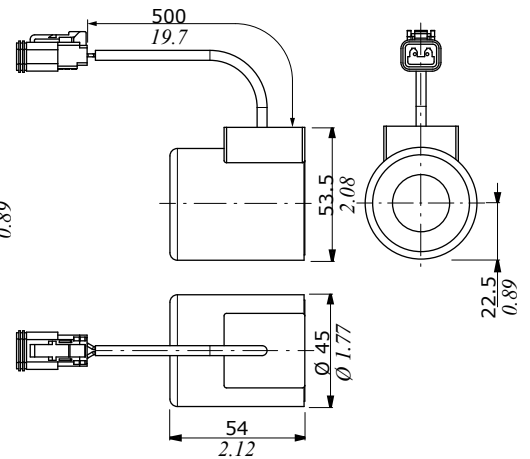

DEUTSCH DT04 connector (Parallel type)

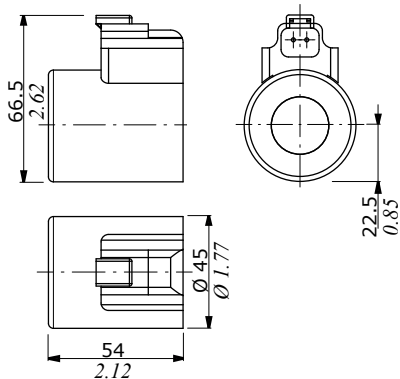

AMP JPT connector (Perpendicular type)

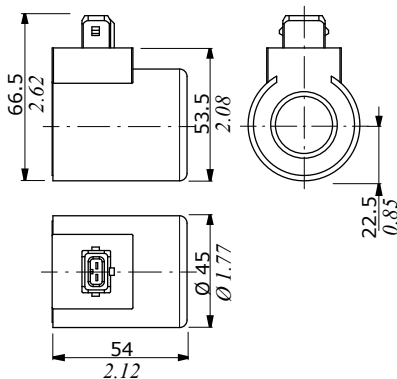

Flying leads with AMP JPT connector

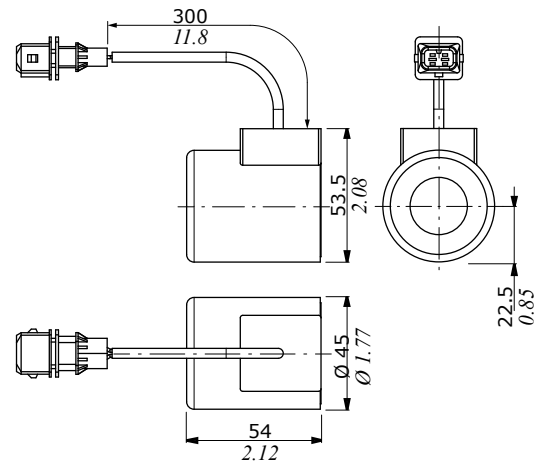



DFE10

Solenoid control monoblock diverter valves

- 3 - 6 ways configuration
- Galvanized body

This catalogue shows technical specifications and diagrams measured with mineral oil of 46 mm²/s (46 cSt) viscosity at 40°C - (104°F) temperature.

WORKING CONDITIONS		
N. of available ways		3 - 6
Max. flow rating		90 l/min (23.7 US gpm)
Max. pressure	without drain	200 bar (2900 psi)
	with drain	315 bar (4600 psi)
Available supply voltage	VDC	see reference page 94
Nominal power		60 W
Internal leakage A(B)⇒T	Δp = 100 bar (1450 psi)	10 cm ³ /min (0.61 in ³ /min)
Fluid		Mineral based oil
Fluid temperature	with NBR (BUNA-N) seals	from -20°C to 80°C (from -4°F to 176°F)
	with FPM (VITON) seals	from -20°C to 100°C (from -4°F to 212°F)
Viscosity	operating range	from 15 to 75 mm ² /s (from 15 to 75 cSt)
	min.	12 mm ² /s (12 cSt)
	max.	400 mm ² /s (400 cSt)
Max. level of contamination		20/18/15 - ISO 4406 - NAS 1638 - class 9
Ambient temperature for working conditions		from -20°C to 50°C (from -4°F to 122°F)

NOTE - For different working conditions please contact Sales Dept.

Available threads

PORTS THREAD		
ALL PORTS	BSP	UN-UNF
DFE10	G 1/2	7/8-14 (SAE 10)
PILOT PORTS		
L	G 1/4	9/16-18 (SAE 6)

Dimensional data - hydraulic circuit - performance data

3 ways

It's possible to obtain 2 ways diverter valve plugging port

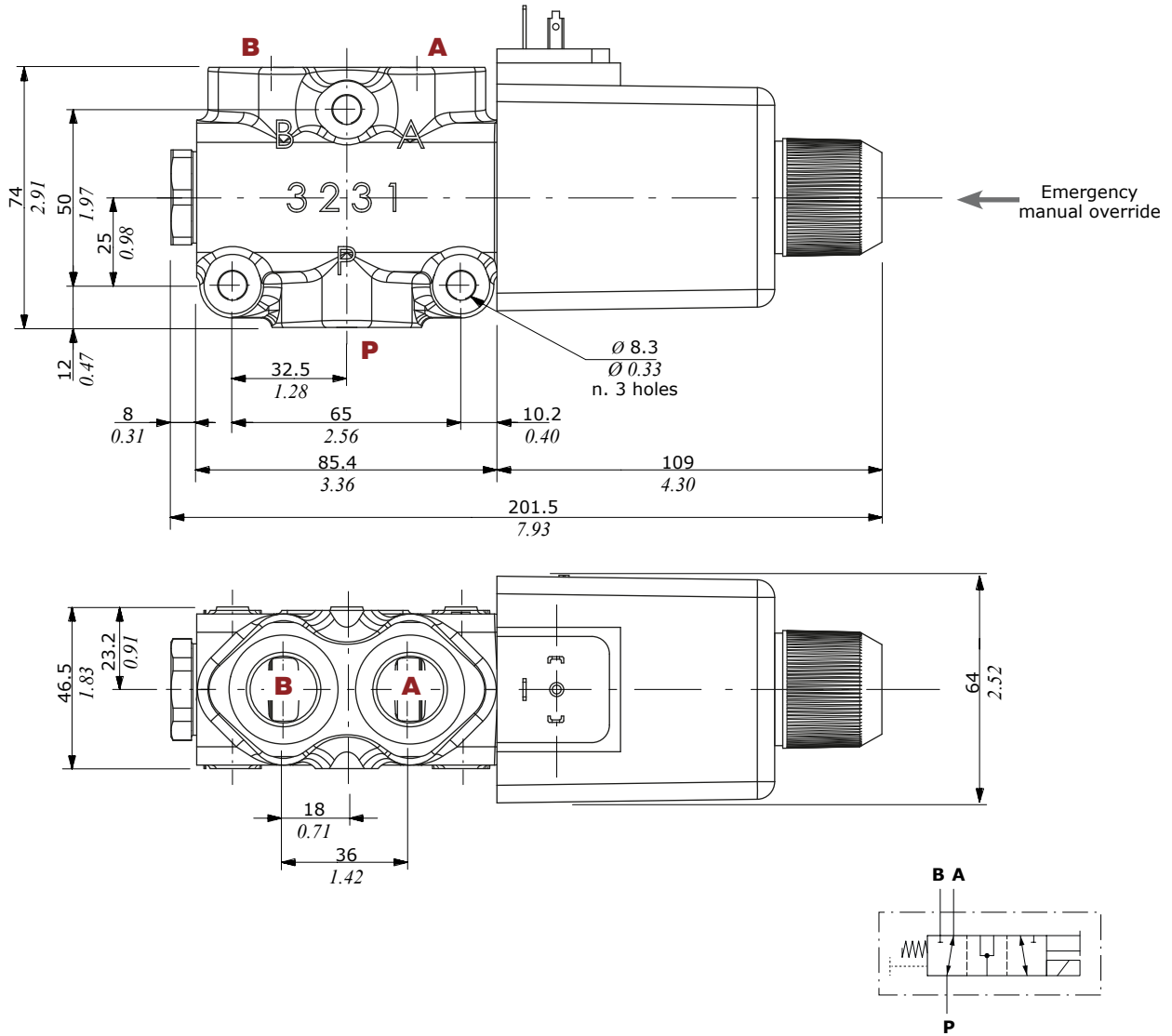

Pressure drop versus flow

P → A(B)

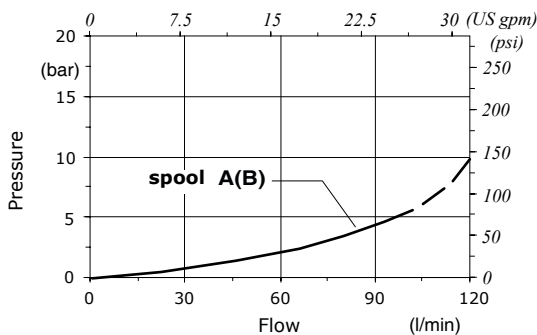

Minimum dynamic conditions

(Supply = Vn-10%, coil at 70 °C - 158 °F)

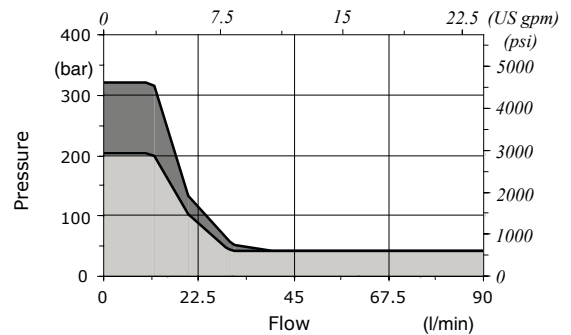

■ With drain
 ■ Without drain

Dimensional data - hydraulic circuit - performance data

6 ways

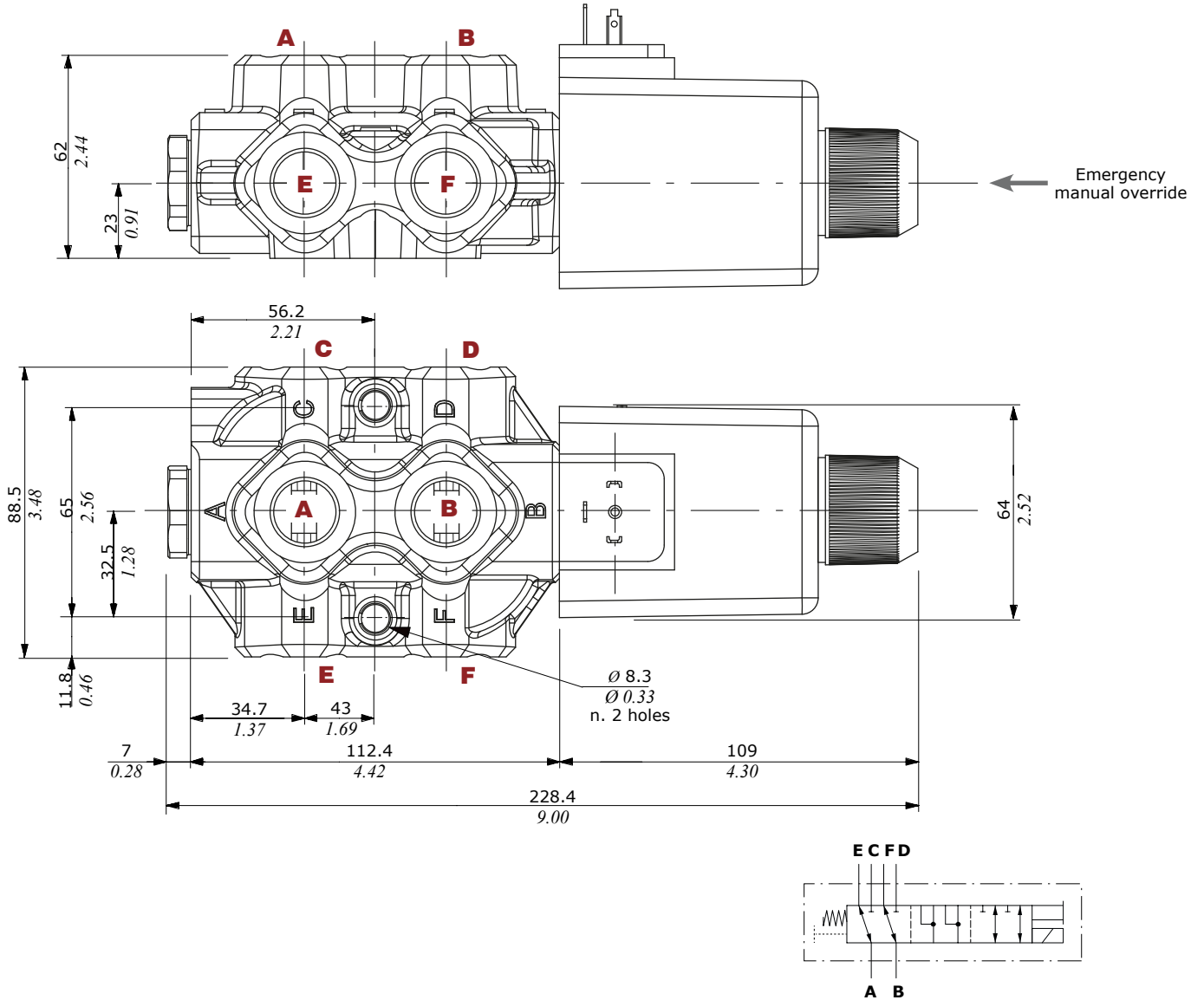

Pressure drop versus flow

A → C(E)

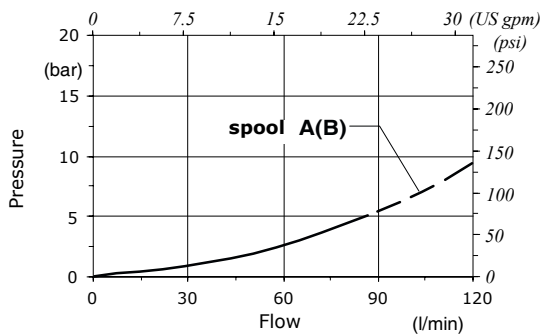

Minimum dynamic conditions

(Supply = Vn-10%, coil at 70 °C - 158 °F)

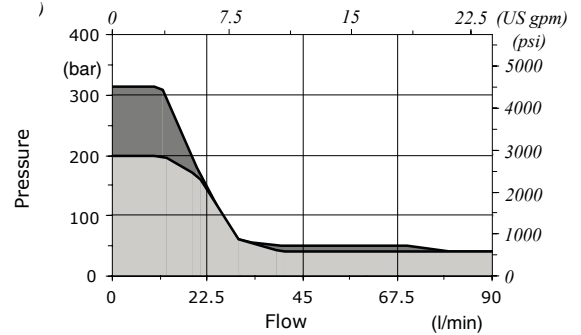

■ With drain
 ■ Without drain

Part ordering codes

Example:

DFE10/3 A 18 ES - W 2 0 2 - 12VDC - SAE - (CRZ)

For description composition see the text below

Galvanized body

Coil
1 = without coil
2 = with coil

Connection*
0 = ISO (Std)
2 = AMP-JPT
3 = Deutsch DT06
4 = Deutsch DT04-2P Male
5 = Deutsch DT04-4P Female
6 = Metri-Pack Female
7 = Metri-Pack Male
8 = WeatherPack Male
9 = WeatherPack Female

... 2 0 (300) 2 - 12VDC - ...

Coil voltage

Bellow
1 = without bellow
2 = with bellow

Lenght cables
(only if it's present)
Lenght is in mm

(*) - For connector options see coils table on page 94

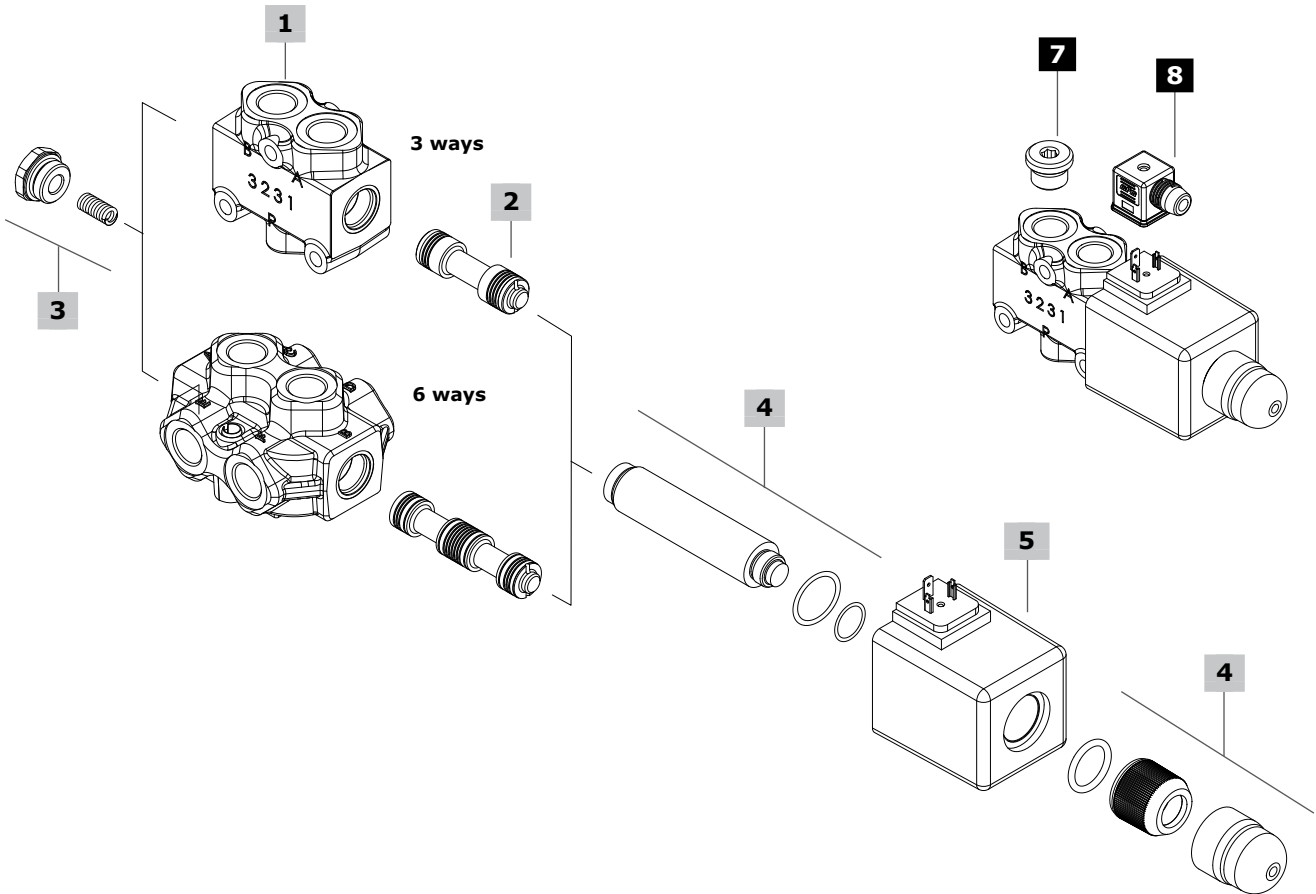

1 Body kit*

TYPE	CODE	DESCRIPTION
DFE10/3	3CO2241720	3 ways body kit
DFE10/6	3CO2242721	6 ways body kit

2 Spools page 92

TYPE	CODE	DESCRIPTION
for DFE10/3:		
A	3CAS110341	Flow in A in neutral. Ports connected in transit position
B	3CAS110441	Flow in A in neutral. Ports closed in transit position
D	3CAS110540	Closed ports in neutral and connected in transit position

for DFE10/6:

A	3CAS110641	Flow in E and F. C and D closed in pos. 1 Ports connected in transit position
B	3CAS110741	Flow in E and F. C and D closed in pos. 1 Ports closed in transit position
H	3CAS110841	D<->C in pos. 1, F<->E in pos. 2 Ports closed in transit position

3 Positioner kit page 93

TYPE	CODE	DESCRIPTION
18...W	5TAP002	Spring return in pos. 1
18...Y	5GIU005*	Spring return in pos. 1, with SAE6 drain port

4 Solenoid kit page 93

TYPE	CODE	DESCRIPTION
ES	5SOL516000A	Tube assembly with protective bellow
ES	5SOL516000B	Tube assembly without protective bellow
-	4ACC516	Optional tube assembly protective bellow

5 Coil

For list of available coils see pages 94

6 Body threading

Specify threading always when it is different from **BSP** standard

7 Port plugs*

It's possible to obtain 2 ways diverter valve plugging port of DFE10/3

CODE	DESCRIPTION
3XTAP826160	SAE10 plug

8 Accessories

For list of available connectors see pages 94

(*) - Codes are referred to **UN-UNF** thread

Spool circuits

3 ways

Type A

Ports connected in transit position

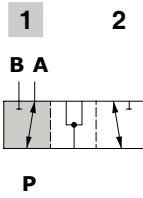

Spool stroke

Position 2: - 4.6 mm (- 0.18 in)

Type B

Ports closed in transit position

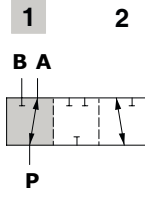

Spool stroke

Position 2: - 4.6 mm (- 0.18 in)

Type D

Closed ports in neutral and connected in transit position

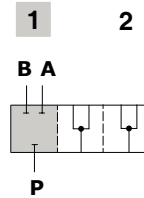

Spool stroke

Position 2: - 4.6 mm (- 0.18 in)

6 ways

Type A

Flow in E and F. C and D closed in pos. 1
Ports connected in transit position

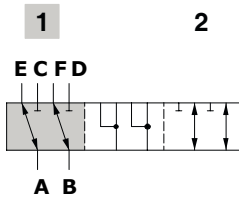

Spool stroke

Position 2: - 4.6 mm (- 0.18 in)

Type B

Flow in E and F. C and D closed in pos. 1
Ports closed in transit position

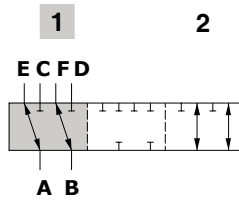

Spool stroke

Position 2: - 4.6 mm (- 0.18 in)

Type H

D<->C in pos. 1, F<->E in pos. 2
Ports closed in transit position

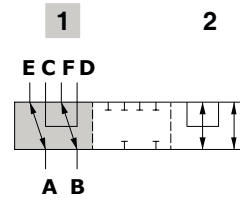

Spool stroke

Position 2: - 4.6 mm (- 0.18 in)

Positioner kit

With spring return in position 1

Type 18W
With plug

Type 18Y
With SAE6 drain port

Wrenches and tightening torque
Z = wrench 27 - 42 Nm (31 lbft)

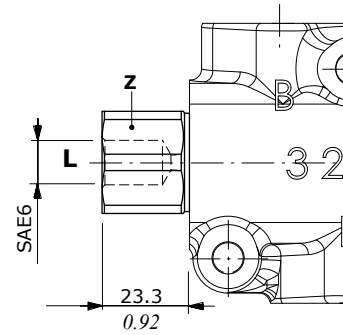
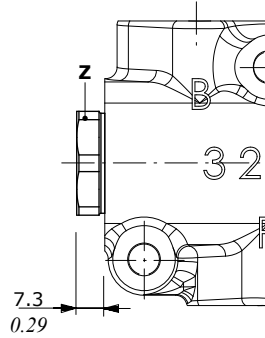
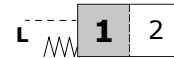

Solenoid kit

ES tube assembly kit

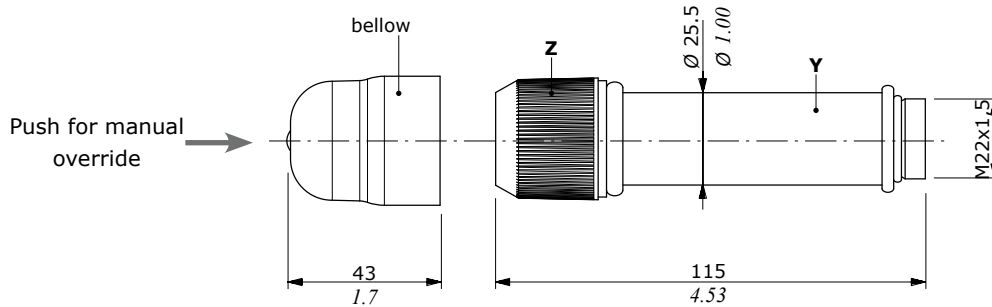

Wrenches and tightening torque
Y = wrench 22 - 24 Nm (17.7 lbft)
Z = 24 Nm (17.7 lbft)

Coils and accessories

Type	Voltage	Ordering codes					Flying leads without connector
		ISO4400	Deutsch DT	AMP JPT	Packard Weatherpack	Packard Metri-pack	
D16	12 VDC	4SOL516012A	4SOL516412A ⁽²⁾	-	-	-	-
	24 VDC	4SOL516024A	4SOL516424A ⁽²⁾	-	-	-	-
	48 VDC	4SOL516048A	-	-	-	-	-
	94 VDC	4SOL516094A	-	-	-	-	-
	110 VDC	4SOL516110A	-	-	-	-	-
	192 VDC	4SOL516192A	-	-	-	-	-
Mating connectors							
		4CN1009995	5CON140031	-	-	-	-

Notes: ⁽¹⁾ supply with AC and use only with rectifier connector - ⁽²⁾ with flying leads - ⁽³⁾ with bidirectional diode - ⁽⁴⁾ with unidirectional diode - ⁽⁵⁾ integrated perpendicular type - ⁽⁶⁾ integrated parallel type

Features

- Nominal voltage tolerance: ±10%
- Nominal power.....: 60 W
12/24/48/94/110/192 VDC
- Nominal current.....: 5 A @ 12 VDC
: 2.5 A @ 24 VDC
: 1.25 A @ 48 VDC
: 0.64 A @ 94 VDC
: 0.55 A @ 110 VDC
: 0.31 A @ 192 VDC
- Insulation.....: Class H (180°C - 356 °F)
- Weather protection.....: IP65 - ISO4400
: IP69K - Deutsch DT
- Insertion.....: 100%

ISO4400 connector

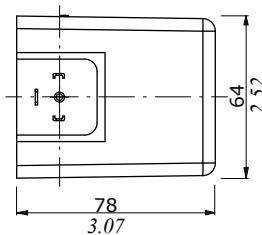
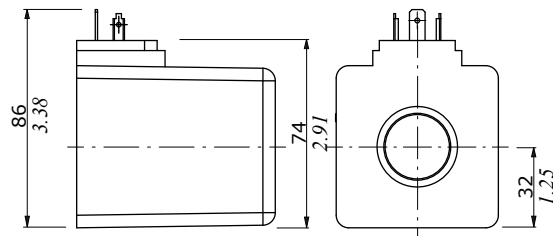

Flying leads with DEUTSCH DT04 connector

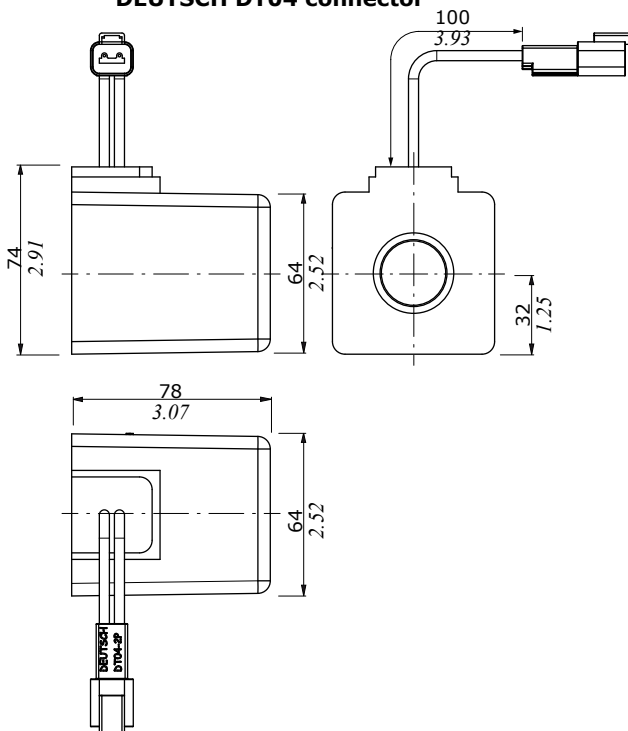



DFE20

Solenoid control monoblock diverter valves

- 3 - 6 ways configuration
- Galvanized body

This catalogue shows technical specifications and diagrams measured with mineral oil of 46 mm²/s (46 cSt) viscosity at 40°C - (104°F) temperature.

WORKING CONDITIONS		
N. of available ways		3 - 6
Max. flow rating		140 l/min (36.9 US gpm)
Max. pressure	without drain	200 bar (2900 psi)
	with drain	315 bar (4600 psi)
Available supply voltage	VDC	see reference page 102
Nominal power		60 W
Internal leakage A(B)⇒T	Δp = 100 bar (1450 psi)	15 cm ³ /min (0.91 in ³ /min)
Fluid		Mineral based oil
Fluid temperature	with NBR (BUNA-N) seals	from -20°C to 80°C (from -4°F to 176°F)
	with FPM (VITON) seals	from -20°C to 100°C (from -4°F to 212°F)
Viscosity	operating range	from 15 to 75 mm ² /s (from 15 to 75 cSt)
	min.	12 mm ² /s (12 cSt)
	max.	400 mm ² /s (400 cSt)
Max. level of contamination		20/18/15 - ISO 4406 - NAS 1638 - class 9
Ambient temperature for working conditions		from -20°C to 50°C (from -4°F to 122°F)

NOTE - For different working conditions please contact Sales Dept.

Available threads

PORTS THREAD		
ALL PORTS	BSP	UN-UNF
DFE20	G 3/4	1" 1/16-12 (SAE 12)
PILOT PORTS		
L	G 1/4	9/16-18 (SAE 6)

Dimensional data - hydraulic circuit - performance data

3 ways

It's possible to obtain 2 ways diverter valve plugging port

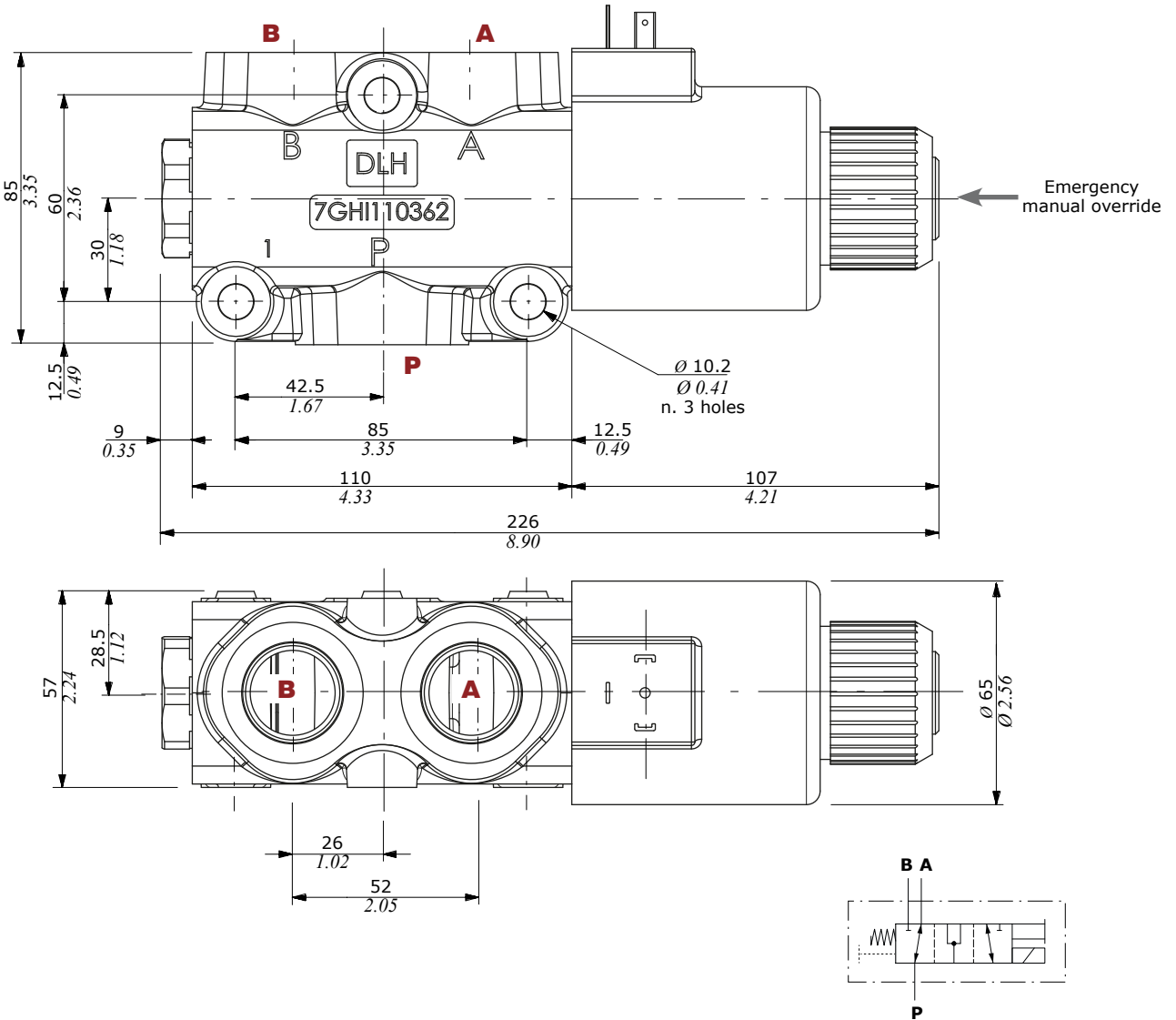

Pressure drop versus flow

P → A(B)

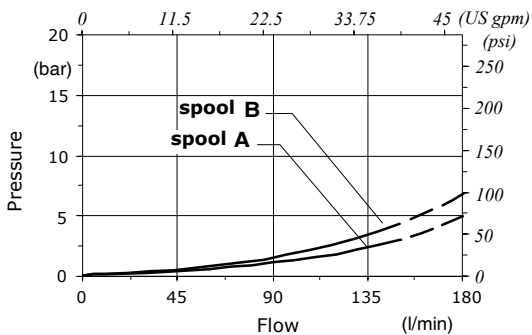

Minimum dynamic conditions

(Supply = Vn-10%, coil at 70 °C - 158 °F)

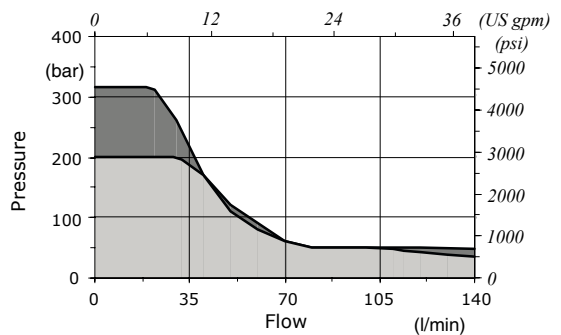

■ With drain
■ Without drain

Dimensional data - hydraulic circuit - performance data

6 ways

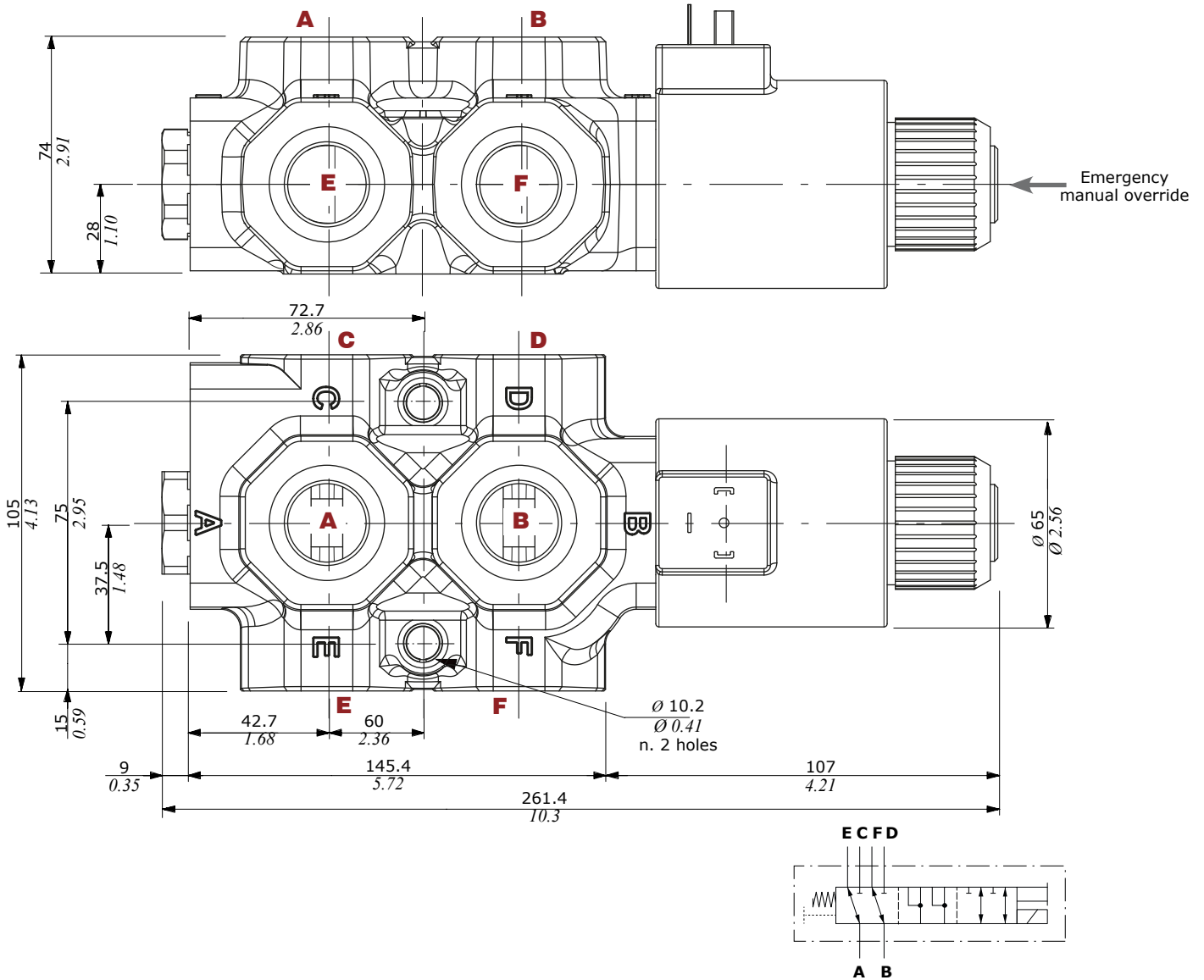

Pressure drop versus flow

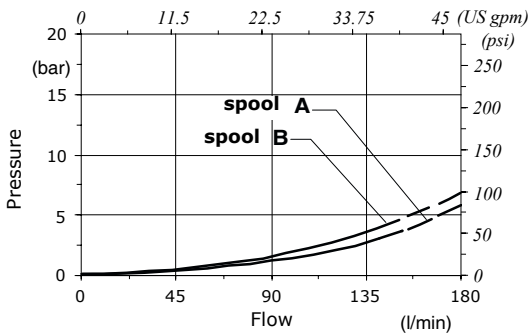

Minimum dynamic conditions

(Supply = Vn-10%, coil at 70 °C - 158 °F)

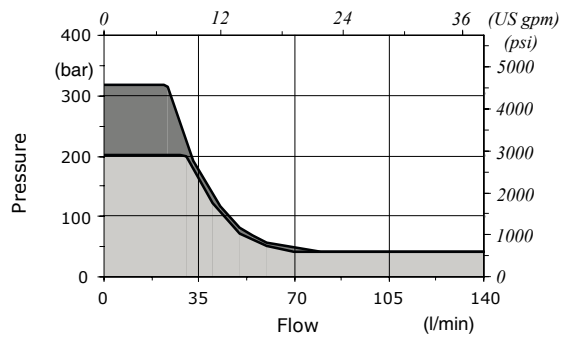

■ **With drain**
 ■ **Without drain**

Part ordering codes

Example:

For description composition
see the text below

DFE20/3 **A** **18** **ES** - **W** **2 0 0 - 12VDC** - **SAE** - **(CRZ)**

1 2 3 4 3 4 5 6 Galvanized body

... **2 0 0 - 12VDC** - ...

Coil
1 = without coil
2 = with coil

Coil voltage

Connection*
0 = ISO (Std)
2 = AMP-JPT
3 = Deutsch DT06
4 = Deutsch DT04-2P Male
5 = Deutsch DT04-4P Female
6 = Metri-Pack Female
7 = Metri-Pack Male
8 = WeatherPack Male
9 = WeatherPack Female

Bellow
0 = bellow not available

(*) - For connector options see coils table on page 102

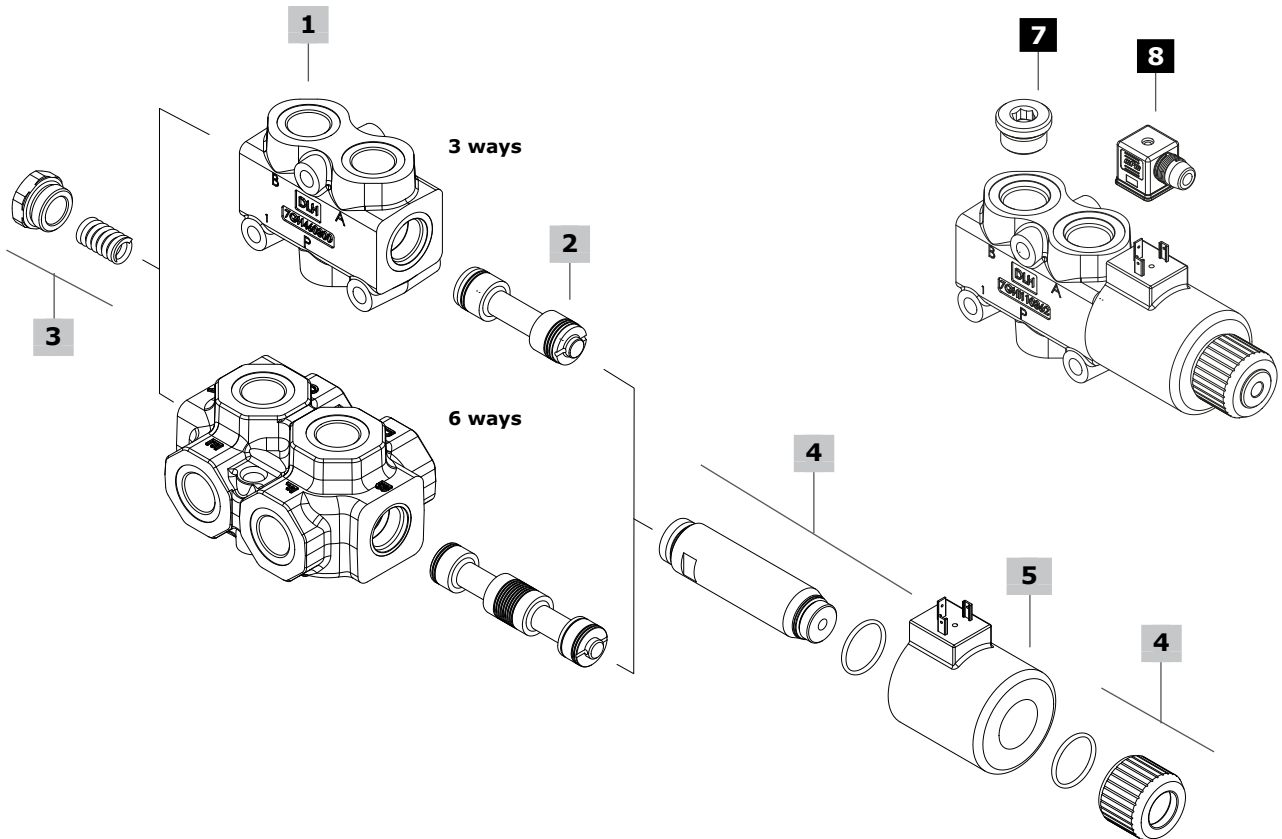

1 Body kit*

TYPE	CODE	DESCRIPTION
DFE20/3	3CO2261721	3 ways body kit
DFE20/6	3CO2263720	6 ways body kit

2 Spools **page 100**

TYPE	CODE	DESCRIPTION
for DFE20/3:		
A	3CAS120341	Flow in A in neutral. Ports connected in transit position
B	3CAS120441	Flow in A in neutral. Ports closed in transit position
for DFE20/6:		
A	3CAS120641	Flow in E and F. C and D closed in pos. 1 Ports connected in transit position
B	3CAS120741	Flow in E and F. C and D closed in pos. 1 Ports closed in transit position
H	3CAS120841	D<->C in pos. 1, F<->E in pos. 2 Ports closed in transit position

3 Positioner kit **page 101**

TYPE	CODE	DESCRIPTION
18...W	5TAP003	Spring return in pos. 1
18...Y	5GIU008*	Spring return in pos. 1, with SAE4 drain port

4 Solenoid kit **page 101**

TYPE	CODE	DESCRIPTION
ES	5SOL519003	Tube assembly without protective bellow

5 Coil

For list of available coils see pages 102

6 Body threading

Specify threading always when it is different from **BSP** standard

7 Port plugs*

It's possible to obtain 2 ways diverter valve plugging port of DFE20/3	
CODE	DESCRIPTION
3XTAP832200	SAE12 plug

8 Accessories

For list of available connectors see pages 102

(*) - Codes are referred to **UN-UNF** thread

Spool circuits

3 ways

Type A

Ports connected in transit position

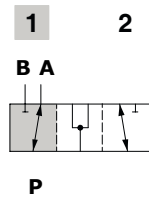

Spool stroke

Position 2: - 4.5 mm (- 0.18 in)

Type B

Ports closed in transit position

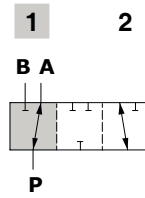

Spool stroke

Position 2: - 4.5 mm (- 0.18 in)

6 ways

Type A

Flow in E and F. C and D closed in pos. 1
Ports connected in transit position

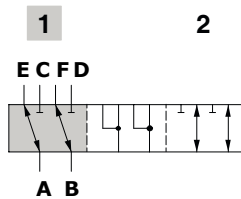

Spool stroke

Position 2: - 4.5 mm (- 0.18 in)

Type B

Flow in E and F. C and D closed in pos. 1
Ports closed in transit position

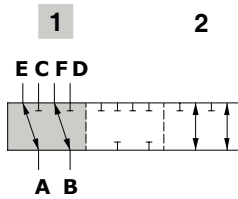

Spool stroke

Position 2: - 4.5 mm (- 0.18 in)

Type H

D->C in pos. 1, F->E in pos. 2
Ports closed in transit position

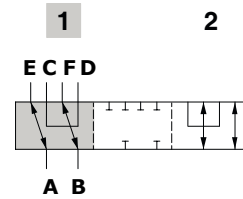

Spool stroke

Position 2: - 4.5 mm (- 0.18 in)

Positioner kit

With spring return in position 1

Type 18W
With plug

Type 18Y
With SAE6 drain port

Wrenches and tightening torque
J = wrench 27 - 24 Nm (17.7 lbft)

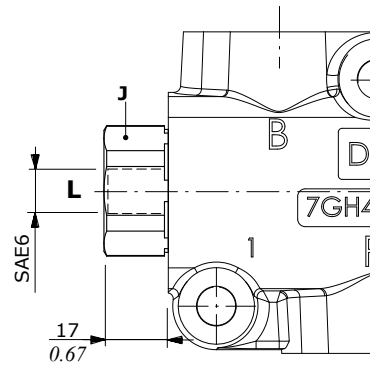
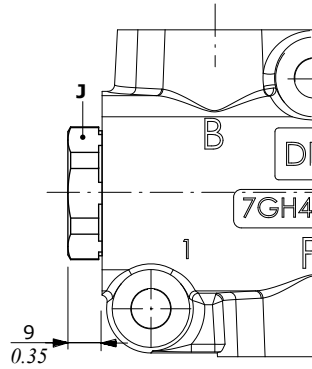
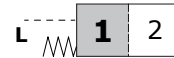

Solenoid kit

ES tube assembly kit

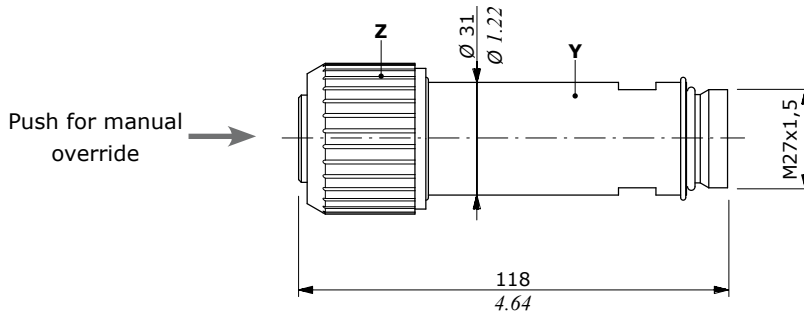

Wrenches and tightening torque
Y = wrench 27 - 24 Nm (17.7 lbft)
Z = 24 Nm (17.7 lbft)

Coil and accessories

		Ordering codes					
Type	Voltage	Connector types					Flying leads without connector
		ISO4400	Deutsch DT	AMP JPT	Packard Weatherpack	Packard Metri-pack	
D19	12 VDC	4SOL519112	4SOL519402 ⁽⁶⁾	-	-	-	-
	20 VDC	4SOL519120	-	-	-	-	-
	24 VDC	4SOL519124	4SOL519404 ⁽⁶⁾	-	-	-	-
	94 VDC	4SOL519194	-	-	-	-	-
	192 VDC	4SOL519292	-	-	-	-	-
Mating connectors		4CN1009995	5CON140031	-	-	-	-

Notes: ⁽¹⁾ supply with AC and use only with rectifier connector - ⁽²⁾ with flying leads - ⁽³⁾ with bidirectional diode - ⁽⁴⁾ with unidirectional diode ⁽⁵⁾ integrated perpendicular type - ⁽⁶⁾ integrated parallel type

Features

Nominal voltage tolerance: ±10%
 Nominal power.....: 60 W
 12/20/24/94/192 VDC
 Nominal current.....: 5 A @ 12 VDC
 : 3 A @ 20 VDC
 : 2.5 A @ 24 VDC
 : 2.5 A @ 94 VDC
 : 0.31 A @ 192 VDC
 Insulation.....: Class H (180°C - 356 °F)
 Weather protection.....: IP65 - ISO4400
 : IP69K - Deutsch DT
 Insertion.....: 100%

ISO4400 connector

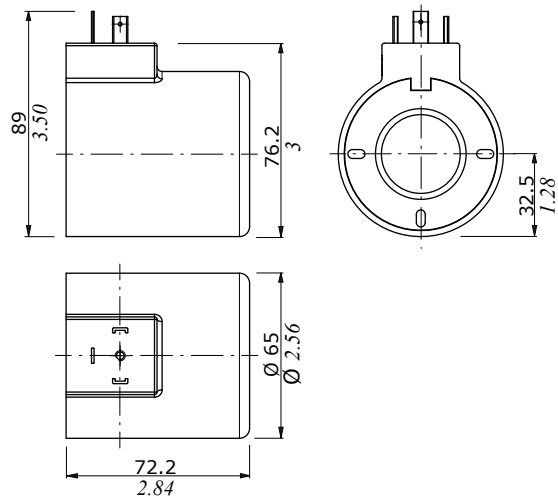

DEUTSCH DT04 connector (Parallel type)

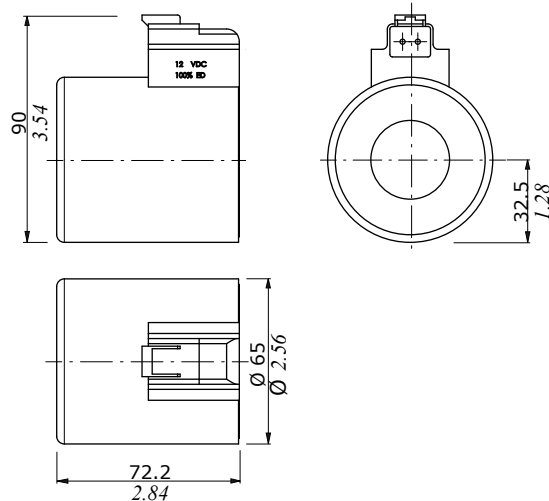



DFE085

Solenoid control monoblock diverter valve for special applications

- 4 ways configuration
- Galvanized body designed for in-line mounting
- Specific design for steering applications
- Mechanical detent on working position

This catalogue shows technical specifications and diagrams measured with mineral oil of 46 mm²/s (46 cSt) viscosity at 40°C - (104°F) temperature.

WORKING CONDITIONS

N. of available ways	4	
Max. flow rating	25 l/min (6.6 US gpm)	
Max. pressure	210 bar (3045 psi)	
Available supply voltage	VDC	see reference page 108
Nominal power	38 W	
Internal leakage A(B)⇒T	Δp = 100 bar (1450 psi)	7 cm ³ /min (0.42 in ³ /min)
Fluid	Mineral based oil	
Fluid temperature	with NBR (BUNA-N) seals	from -20°C to 80°C (from -4°F to 176°F)
	with FPM (VITON) seals	from -20°C to 100°C (from -4°F to 212°F)
Viscosity	operating range	from 15 to 75 mm ² /s (from 15 to 75 cSt)
	min.	12 mm ² /s (12 cSt)
	max.	400 mm ² /s (400 cSt)
Max. level of contamination	20/18/15 - ISO 4406 - NAS 1638 - class 9	
Ambient temperature for working conditions	from -40°C to 60°C (from -40°F to 140°F)	

NOTE - For different working conditions please contact Sales Dept.

Available threads

PORTS THREAD			METRIC*	METRIC*
	BSP	UN-UNF	(ISO 9974-1)	(ISO 6149)
ALL PORTS				
DFE085	G 3/8	3/4-16 (SAE 8)	M16x1.5	M16x1.5

(*) Optional threads
for availability contact Sales
Department

Dimensional data and hydraulic circuit

4 ways

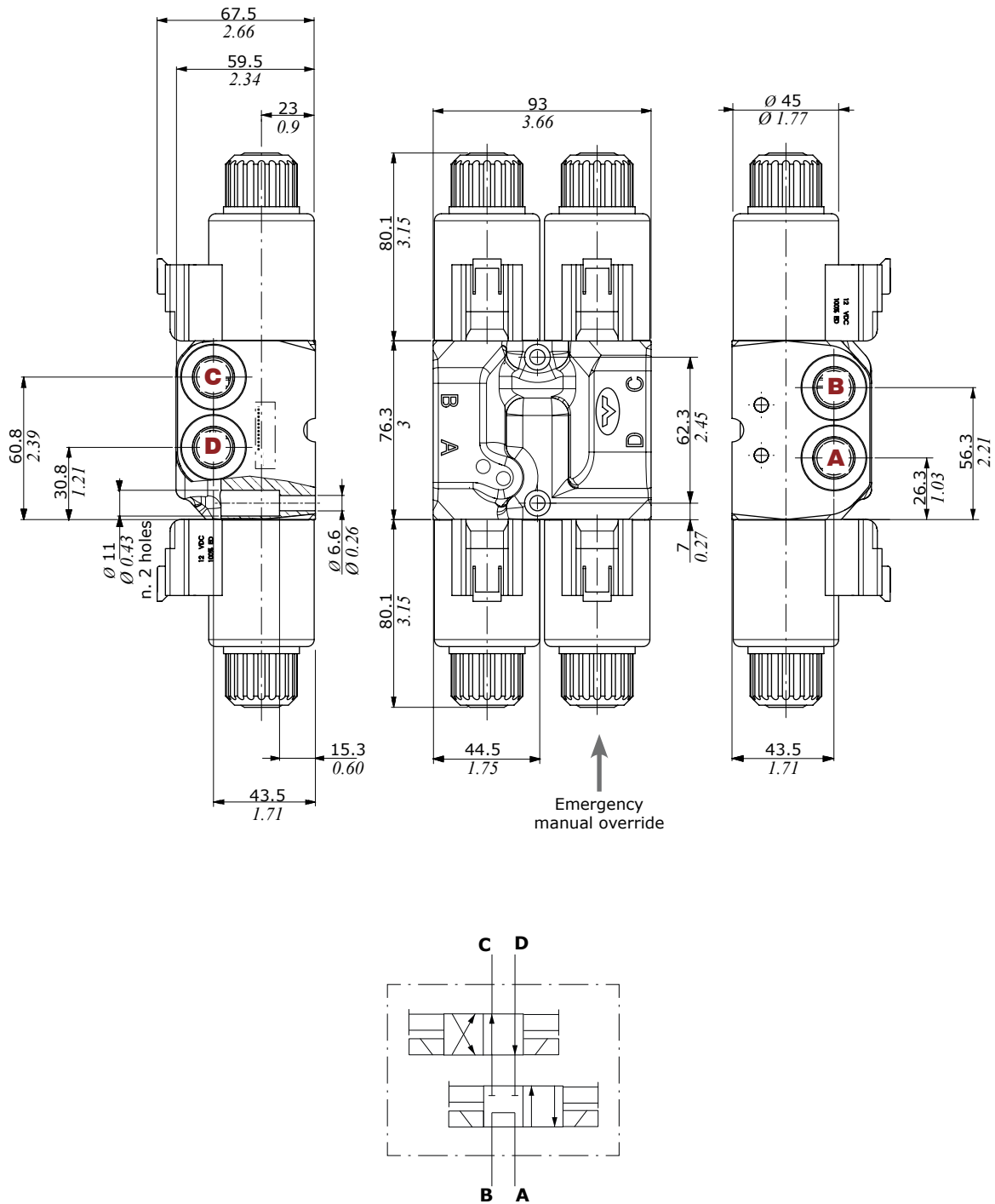

Pressure drop versus flow :

"Crab" function

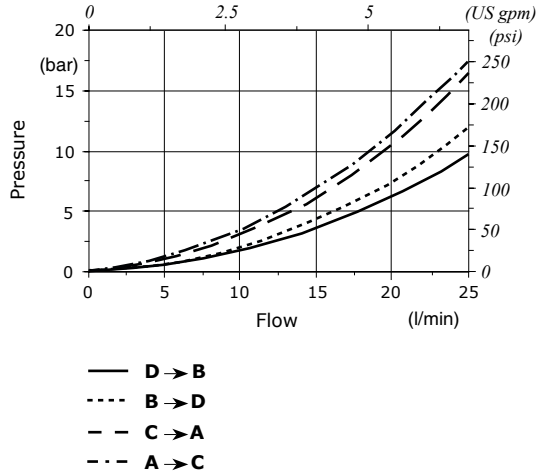

"Anterior" function

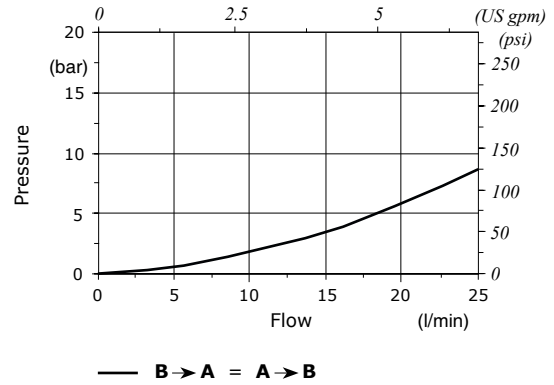

"Leading" function

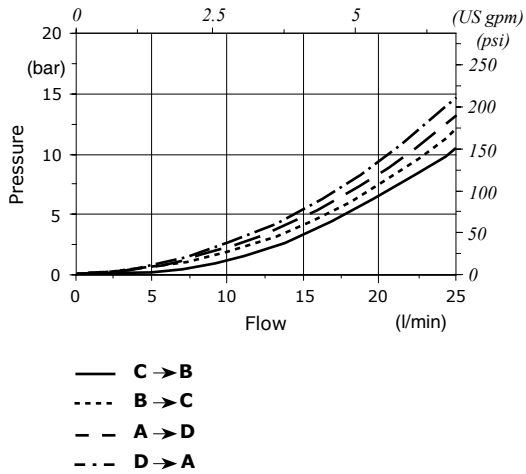

Minimum dynamic conditions
(Supply = Vn-10%, coil at 70 °C - 158 °F)

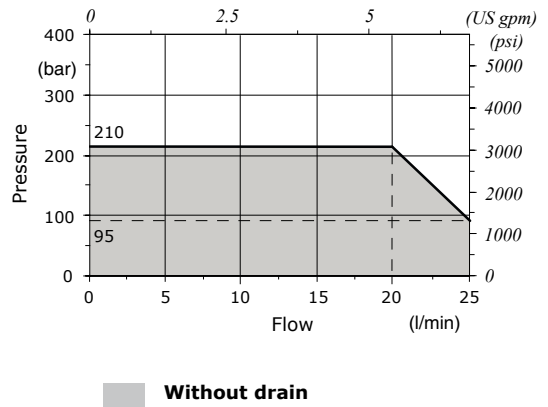

Spool circuits

Type A-B

C - D ports closed
in neutral position

1 2

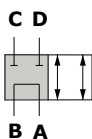

Spool stroke

Position 2: + 3 mm (0.11 in)

Type C-D

C - D ports connected
in neutral position

1 2

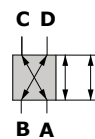

Spool stroke

Position 2: + 3 mm (0.11 in)

Complete controls

With spring return in position 2

Type 16ES3

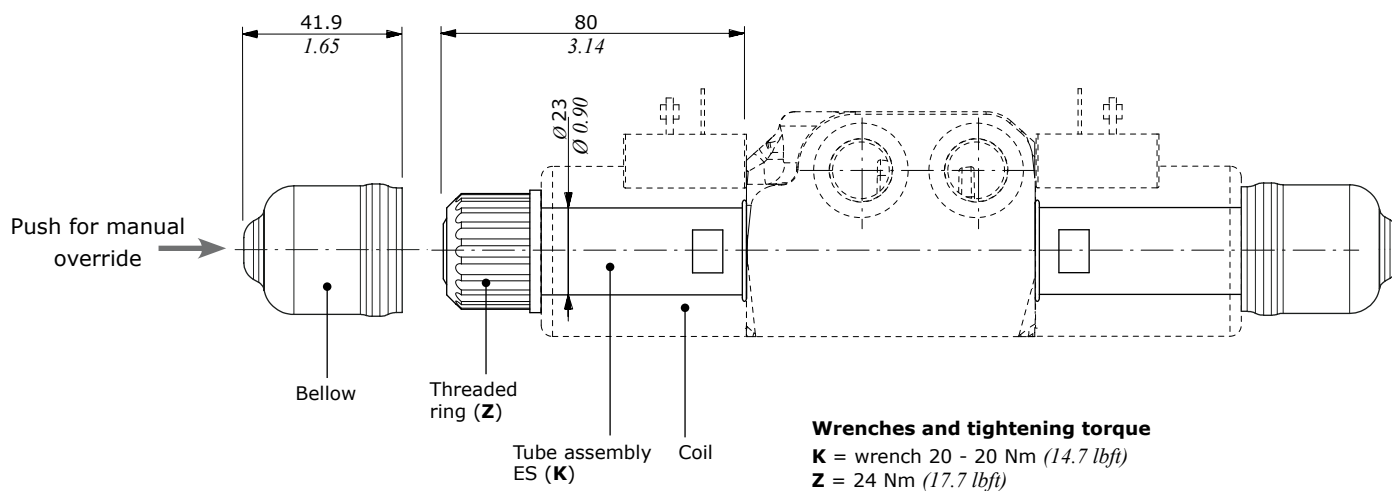
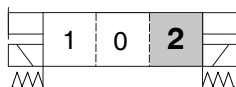

Coils and accessories

Type	Voltage	Ordering codes					
		ISO4400	Deutsch DT	AMP JPT	Packard Weatherpack	Packard Metri-pack	Flying leads without connector
D15	12 VDC	4SOL515012	4SOL515011 ⁽²⁾ 4SOL515014A ⁽³⁻⁶⁾	4SOL515016 ⁽⁵⁾	-	-	-
	14 VDC	-	4SOL515014B ⁽³⁻⁶⁾	4SOL515016A ⁽⁵⁾	-	-	-
	24 VDC	4SOL515024	4SOL515025A ⁽³⁻⁶⁾ 4SOL515021 ⁽²⁾	-	-	-	-
	48 VDC	4SOL515048	-	4SOL515049 ⁽²⁾	-	-	-
	98 VDC	4SOL515098	-	-	-	-	-
	110 VDC	4SOL515110	-	-	-	-	-
Mating connectors		4CN1009995	5CON140031	5CON003	-	-	-

Notes: (1) supply with AC and use only with rectifier connector - (2) with flying leads - (3) with bidirectional diode - (4) with unidirectional diode - (5) integrated perpendicular type - (6) integrated parallel type

Features

Nominal voltage tolerance: ±10%

Nominal power.....: 38 W

Nominal current.....: 12/14/24/48/98/110 VDC

: 3.16 A @ 12 VDC

: 2.9 A @ 14 VDC

: 1.58 A @ 24 VDC

: 0.79 A @ 48 VDC

: 0.41 A @ 98 VDC

: 0.35 A @ 110 VDC

Insulation.....: Class H (180°C - 356°F)

Weather protection.....: IP65 - ISO4400

: IP69K - Deutsch DT

: IP65 - AMP JPT

Insertion.....: 100%

ISO4400 connector

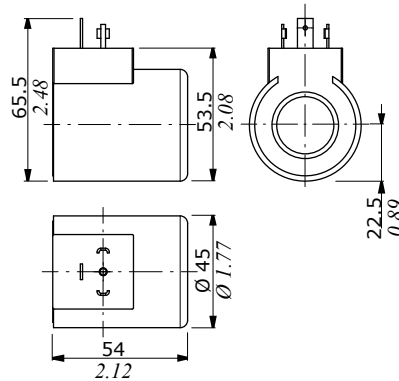

Flying leads with DEUTSCH DT04 connector

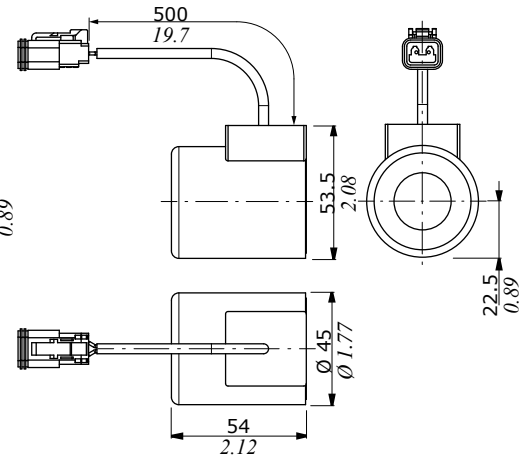

DEUTSCH DT04 connector (Parallel type)

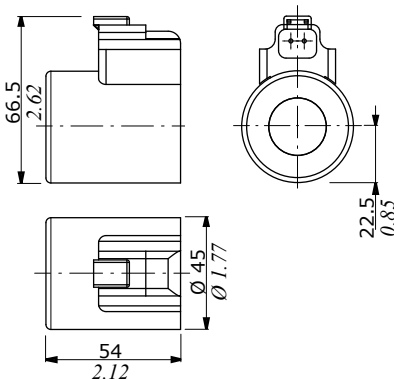

AMP JPT connector (Perpendicular type)

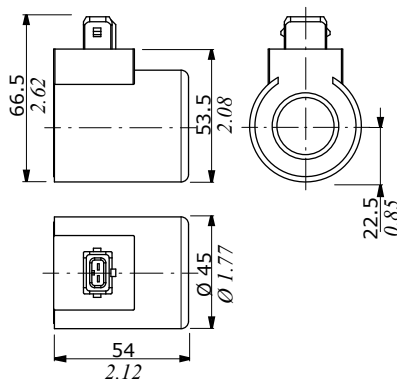

Flying leads with AMP JPT connector

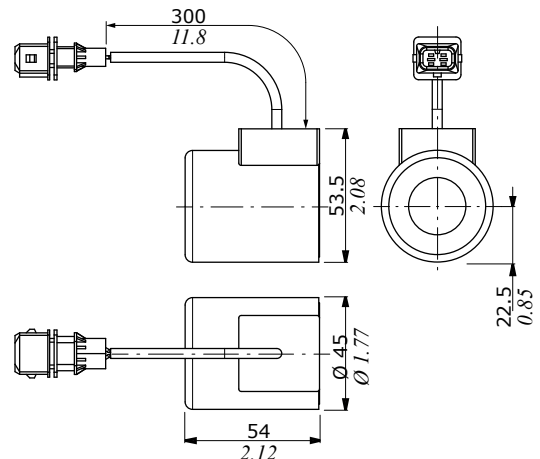



DFE110

Solenoid control monoblock diverter valve for special applications

- 12 ways configuration
- Galvanized body
- Designed for Front-end Loader Applications

This catalogue shows technical specifications and diagrams measured with mineral oil of 46 mm²/s - 46 cSt viscosity at 40°C - 104°F temperature.

WORKING CONDITIONS		
N. of available ways		12
Max. flow rating		90 l/min (23.7 US gpm)
Max. pressure	without drain	200 bar (2900 psi)
	with drain	315 bar (4600 psi)
Available supply voltage	VDC	see reference page 114
Nominal power		60 W
Internal leakage A(B)⇒T	Δp = 100 bar (1450 psi)	10 cm ³ /min (0.61 in ³ /min)
Fluid		Mineral based oil
Fluid temperature	with NBR (BUNA-N) seals	from -20°C to 80°C (from -4°F to 176°F)
	with FPM (VITON) seals	from -20°C to 100°C (from -4°F to 212°F)
Viscosity	operating range	from 15 to 75 mm ² /s (from 15 to 75 cSt)
	min.	12 mm ² /s (12 cSt)
	max.	400 mm ² /s (400 cSt)
Max. level of contamination		20/18/15 - ISO 4406 - NAS 1638 - class 9
Ambient temperature for working conditions		from -20°C to 50°C (from -4°F to 122°F)

NOTE - For different working conditions please contact Sales Dept.

Available threads

PORTS THREAD				
ALL PORTS	BSP	UN-UNF	METRIC* (ISO 9974-1)	METRIC* (ISO 6149)
DFE110	G 1/2	7/8-14 (SAE 10)	M22x1.5	M22x1.5
PILOT PORTS				
L	G 1/4	9/16-18 (SAE 6)	M12x1.5	M12x1.5

(*) Optional threads
for availability contact Sales
Department

Dimensional data and hydraulic circuit

12 ways

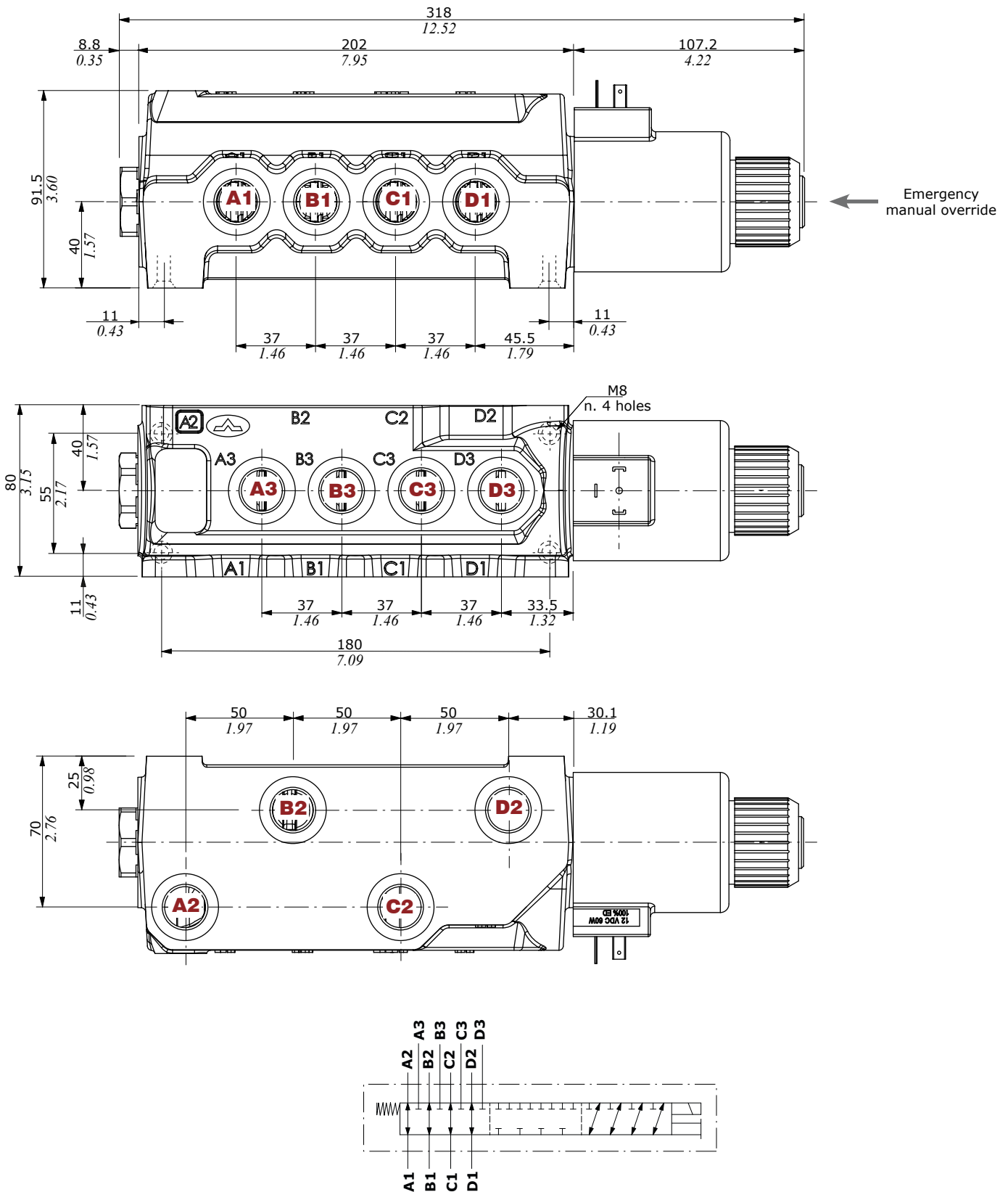

Performance data

Pressure drop versus flow

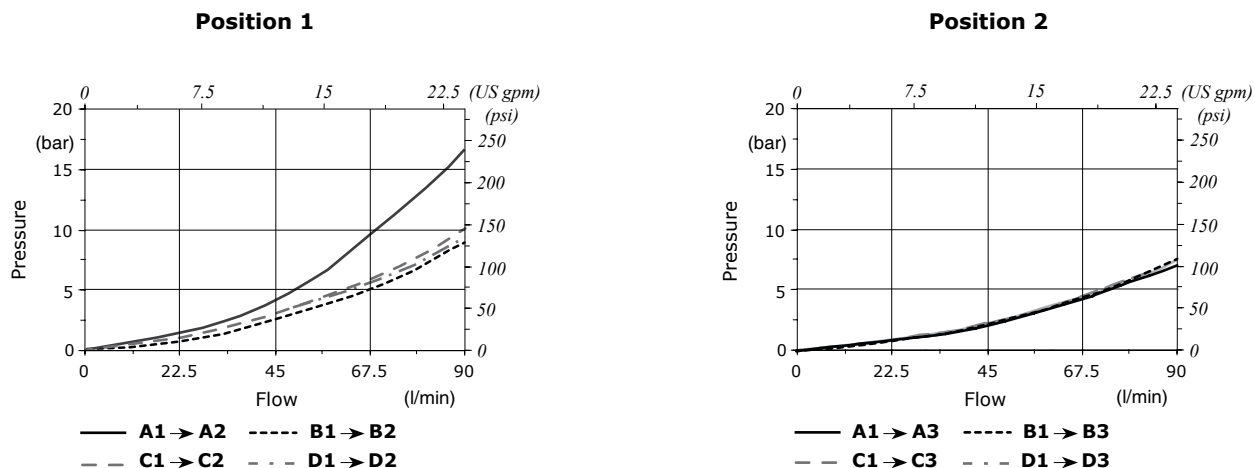

Minimum dynamic conditions

(Supply = Vn-10%, coil at 70 °C - 158 °F)

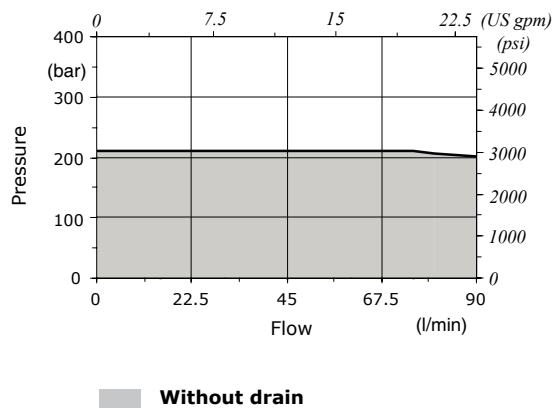

Part ordering codes

Example:

For description composition
see the text below

DFE110/12 **B** **18** **ES** - **W** **2 0 0 - 12VDC** - **SAE** - **(CRZ)**

1 2 3 4 3 4 5 6 Galvanized body

... **2 0 0 - 12VDC** - ...

Coil
1 = without coil
2 = with coil

Connection*
0 = ISO (Std)
2 = AMP-JPT
3 = Deutsch DT06
4 = Deutsch DT04-2P Male
5 = Deutsch DT04-4P Female
6 = Metri-Pack Female
7 = Metri-Pack Male
8 = WeatherPack Male
9 = WeatherPack Female

Bellow
0 = bellow not available

Coil voltage

(*) - For connector options see coils table on page 114

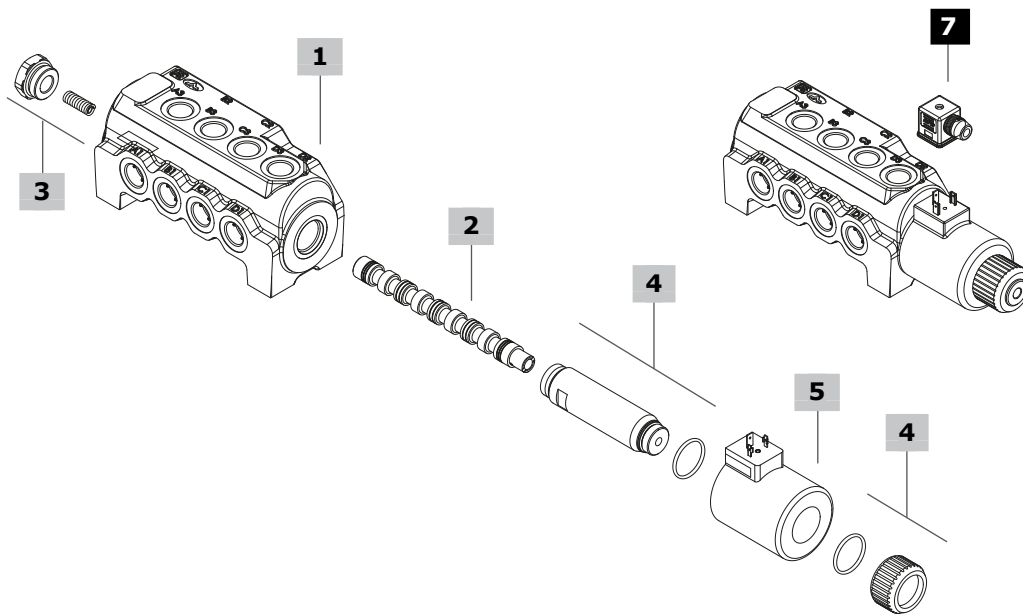

1 Body kit* page 113

TYPE	CODE	DESCRIPTION
DFE110/12	3CO2243720	12 ways body kit

2 Spool page 113

TYPE	CODE	DESCRIPTION
B	3CAS108H40	A1->A2, B1->B2, C1->C2, D1->D2 in pos. 1, A1->A3, B1->B3, C1->C3, D1->D3 in pos. 2. Ports closed in transit position

3 Positioner kit page 113

TYPE	CODE	DESCRIPTION
18...W	5TAP005	Spring return in pos. 1
18...Y	5GIU011*	Spring return in pos. 1, with SAE6 drain port

4 Solenoid kit page 113

TYPE	CODE	DESCRIPTION
ES	5SOL519003	Tube assembly without protective bellow

5 Coil

For list of available coils see pages 114

6 Body threading

Specify threading always when it is different from **BSP** standard

7 Accessories

For list of available connectors see pages 114

(*) - Codes are referred to **UN-UNF** thread

Spool circuit

Type B
Ports closed
in transit position

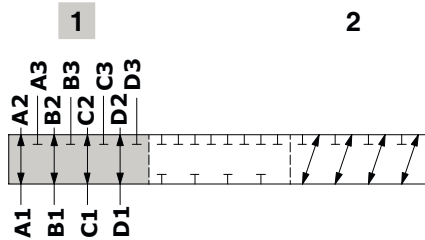

Spool stroke
Position 2: + 5.8 mm (0.23 in)

Positioner kit

With spring return in position 1

Type 18W
With plug



Type 18Y
with SAE6 drain port



Wrenches and tightening torque
Z = wrench 32 - 42 Nm (31 lbft)

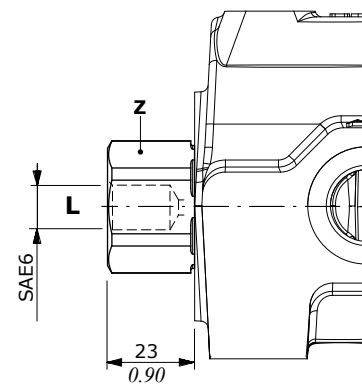
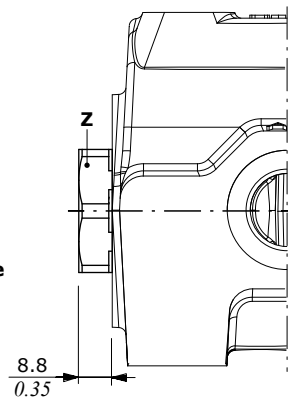

Solenoid kit

ES tube assembly kit

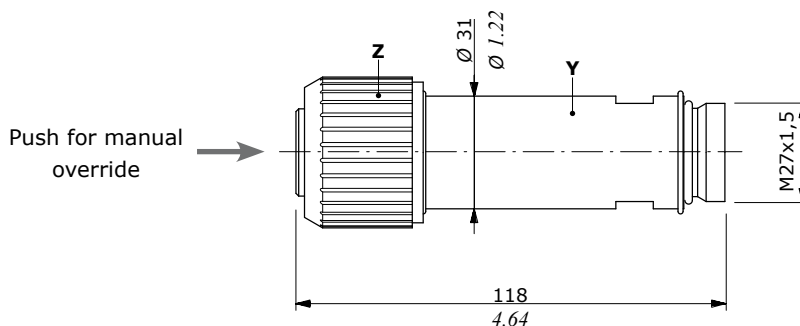

Wrenches and tightening torque
Y = wrench 27 - 24 Nm (17.7 lbft)
Z = 24 Nm (17.7 lbft)

Coil and accessories

Type	Voltage	Ordering codes					Flying leads without connector
		ISO4400	Deutsch DT	AMP JPT	Packard Weatherpack	Packard Metri-pack	
D19	12 VDC	4SOL519112	4SOL519402 ⁽⁶⁾	-	-	-	-
	20 VDC	4SOL519120	-	-	-	-	-
	24 VDC	4SOL519124	4SOL519404 ⁽⁶⁾	-	-	-	-
	94 VDC	4SOL519194	-	-	-	-	-
	192 VDC	4SOL519292	-	-	-	-	-
Mating connectors		4CN1009995	5CON140031	-	-	-	-

Notes: ⁽¹⁾ supply with AC and use only with rectifier connector - ⁽²⁾ with flying leads - ⁽³⁾ with bidirectional diode - ⁽⁴⁾ with unidirectional diode - ⁽⁵⁾ integrated perpendicular type - ⁽⁶⁾ integrated parallel type

Features

Nominal voltage tolerance: $\pm 10\%$
 Nominal power.....: 60 W
 12/20/24/94/192 VDC
 Nominal current.....: 5 A @ 12 VDC
 : 3 A @ 20 VDC
 : 2.5 A @ 24 VDC
 : 2.5 A @ 94 VDC
 : 0.31 A @ 192 VDC
 Insulation.....: Class H (180°C - 356 °F)
 Weather protection.....: IP65 - ISO4400
 : IP69K - Deutsch DT
 Insertion.....: 100%

ISO4400 connector

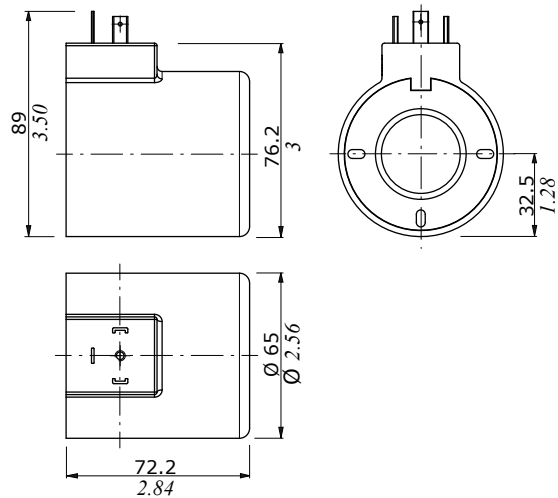

DEUTSCH DT04 connector (Parallel type)

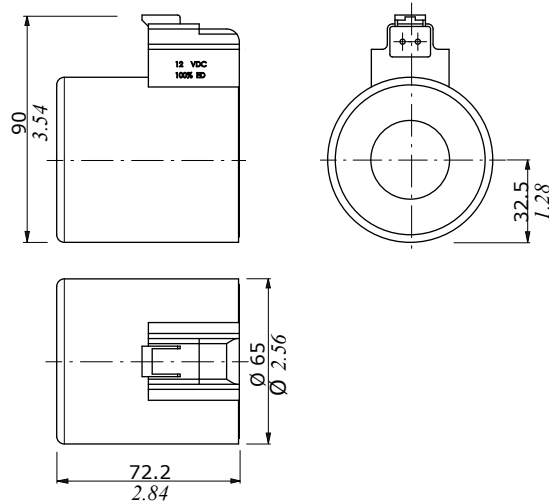



DFE141

Solenoid control monoblock diverter valve for special applications

- 6 - 8 ways configuration
- Antishock valves with cross return
- Double outlet ports in neutral position; for nr. 2 cylinder connection
- Designed for Front-end Loader Applications

This catalogue shows technical specifications and diagrams measured with mineral oil of 46 mm²/s (46 cSt) viscosity at 40°C - (104°F) temperature.

WORKING CONDITIONS		
N. of available ways		6 - 8
Max. flow rating		80 l/min - (21.1 US gpm)
Max. pressure		250 bar - (3625 psi)
	D1-D2-C1-C2 ports	315 bar (4600 psi)
Available supply voltage	VDC	see reference page 122
Nominal power		60 W
Internal leakage A(B)⇒T	Δp = 100 bar (1450 psi)	5 cm ³ /min (0.31 in ³ /min)
Fluid		Mineral based oil
Fluid temperature	with NBR (BUNA-N) seals	from -20°C to 80°C (from -4°F to 176°F)
	with FPM (VITON) seals	from -20°C to 100°C (from -4°F to 212°F)
Viscosity	operating range	from 15 to 75 mm ² /s (from 15 to 75 cSt)
	min.	12 mm ² /s (12 cSt)
	max.	400 mm ² /s (400 cSt)
Max. level of contamination		20/18/15 - ISO 4406 - NAS 1638 - class 9
Ambient temperature for working conditions		from -40°C to 60°C (from -40°F to 140°F)

NOTE - For different working conditions please contact Sales Dept.

Available threads

PORTS THREAD	
ALL PORTS	BSP
DFE141	G 1/2

Dimensional data - hydraulic circuit - performance data

8 ways

8ES3 configuration

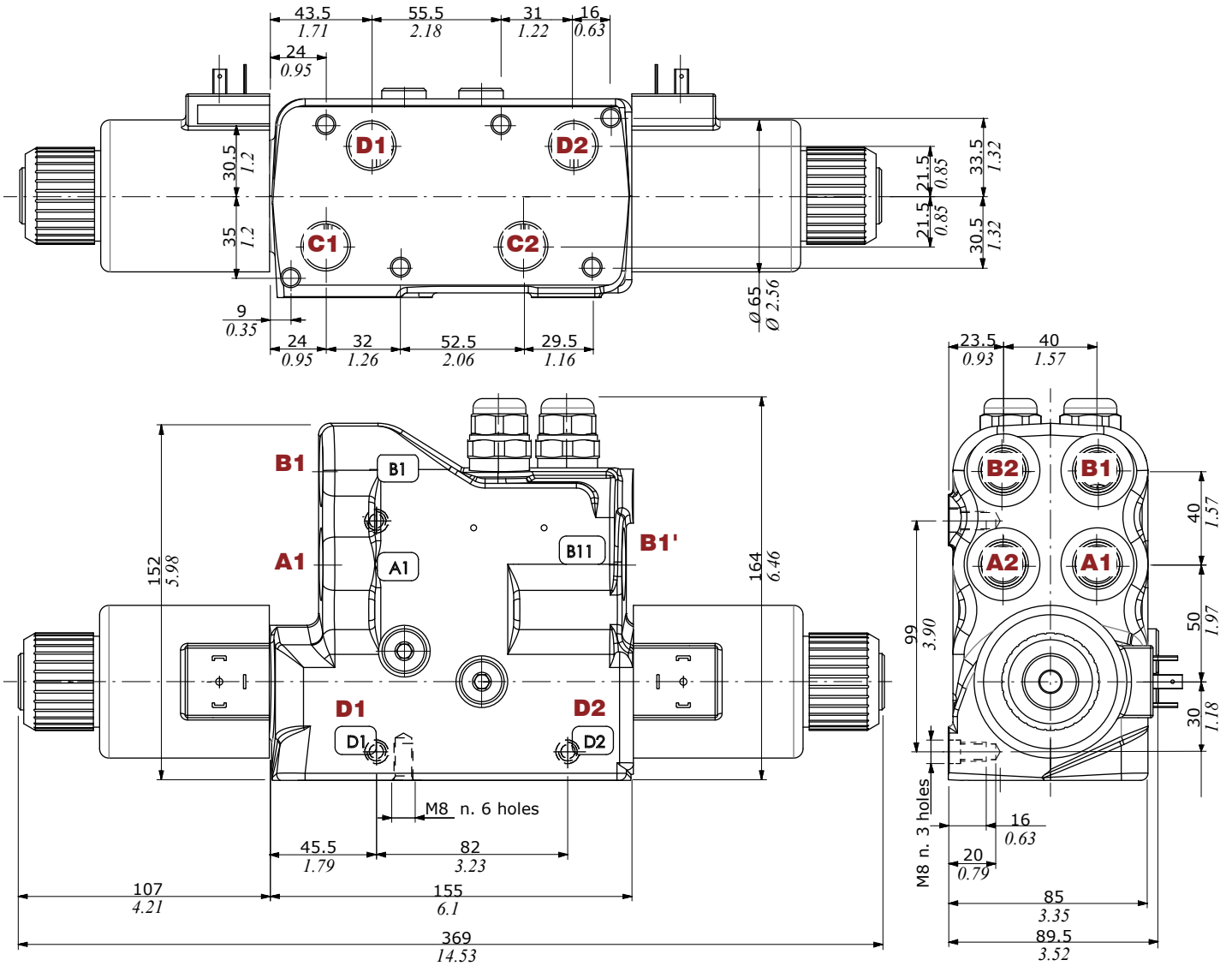

Minimum dynamic conditions

Pressure drop versus flow

(Supply = Vn-10%, coil at 70 °C - 158 °F)

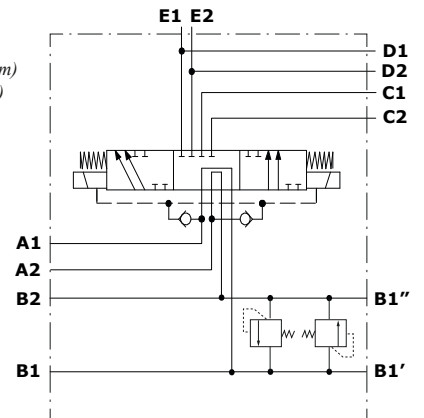
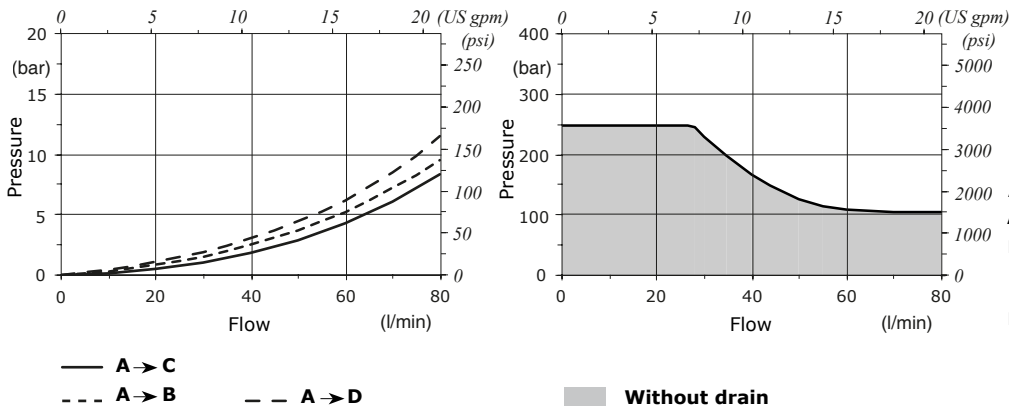

Dimensional data and hydraulic circuit

6 ways

8ES1 configuration

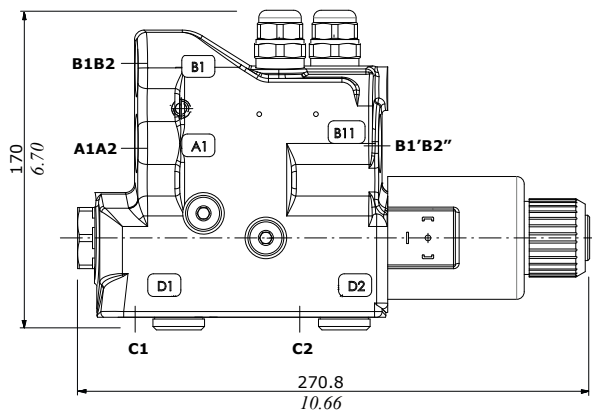

8ES2 configuration

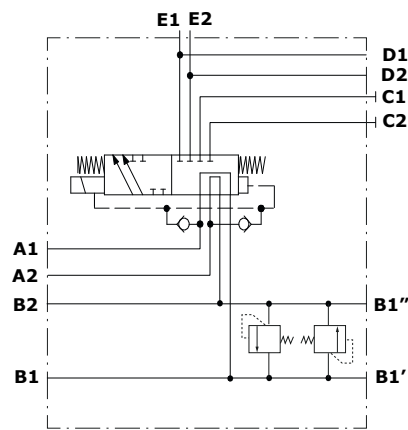
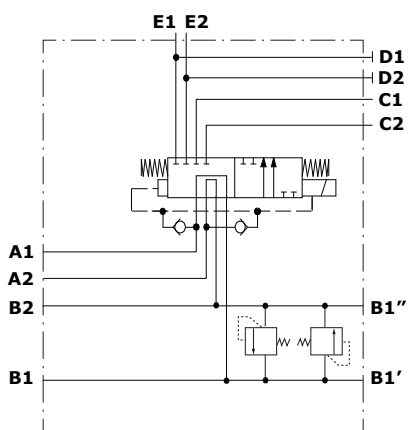
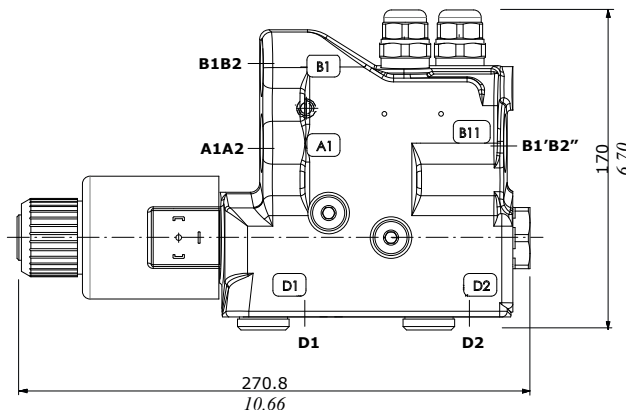

Part ordering codes

8 ways standard configuration example (ES3):

For description composition
see next page

DFE141/8 **B** **8** **ES3** - **P3(D4-210)** - **2 0 0 - 12VDC** - ... - **(CRZ)**
 1 2 3 4 5 4 7 8 Galvanized body

Coil
1 = without coil
2 = with coil

... **2 0 0 - 12VDC** - ... Coil voltage

Bellow
0 = bellow not available

Connection*
0 = ISO (Std)
2 = AMP-JPT
3 = Deutsch DT06
4 = Deutsch DT04-2P Male
5 = Deutsch DT04-4P Female
6 = Metri-Pack Female
7 = Metri-Pack Male
8 = WeatherPack Male
9 = WeatherPack Female

(*) - For connector options see coils table on page 122

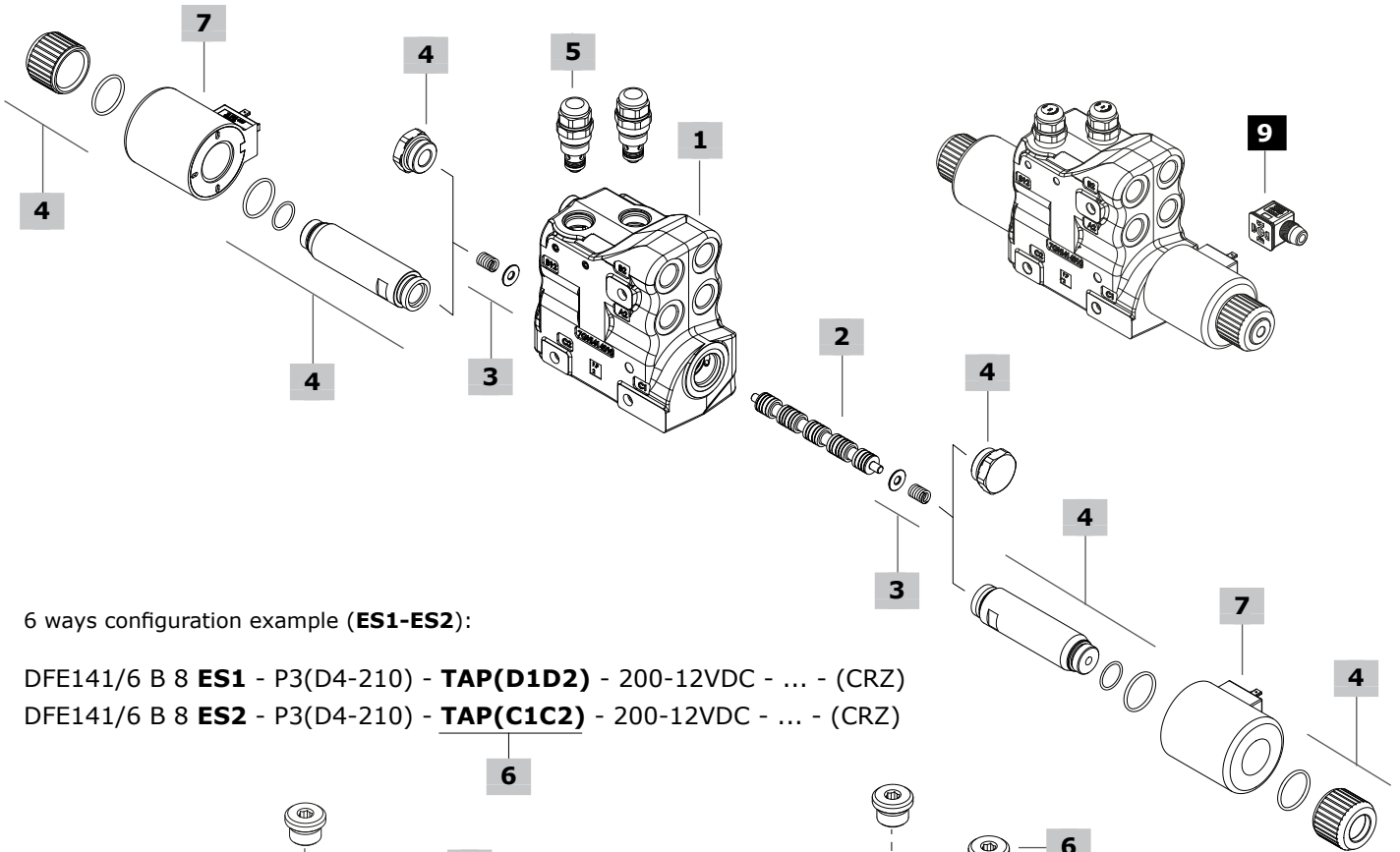

6 ways configuration example (ES1-ES2):

DFE141/6 B 8 **ES1** - P3(D4-210) - **TAP(D1D2)** - 200-12VDC - ... - (CRZ)

DFE141/6 B 8 **ES2** - P3(D4-210) - **TAP(C1C2)** - 200-12VDC - ... - (CRZ)

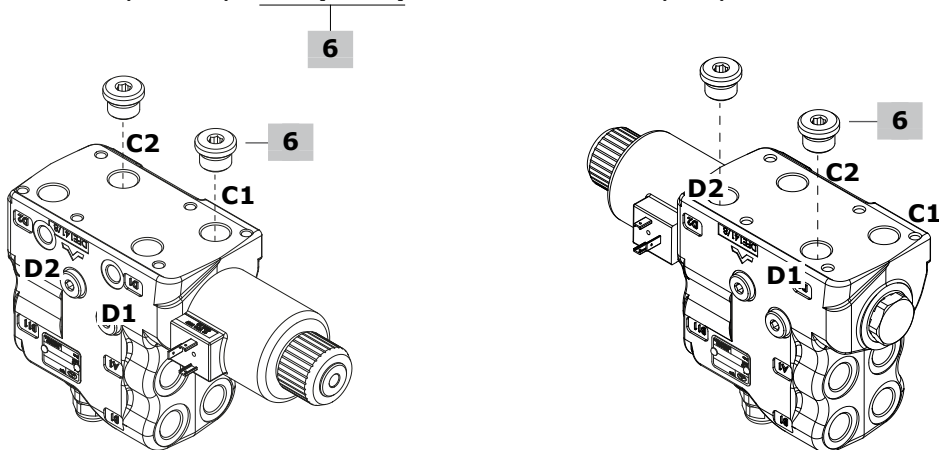

8ES2 control

8ES1 control

Part ordering codes

1 Body kit*

TYPE	CODE	DESCRIPTION
DFE141/8	5CO2231351	8 ways body kit

2 Spool **page 119**

TYPE	CODE	DESCRIPTION
B	3CAS110B71	A1↔B1, A2↔B2 and D1, D2, C1, C2 ports closed in pos. 0 A1↔D1, A2↔D2 and B1, B2, C1, C2 ports closed in pos. 1 A1↔C1, A2↔C2 and D1, D2, B1, B2 ports closed in pos. 2

3 Positioner kit

TYPE	CODE	DESCRIPTION
8	5V08001	Spring return in pos. 0

4 ES control kit **page 120**

TYPE: **ES3** CODE: 5SOL519003 (n°2)
DESCRIPTION: 3 positions control for 8-way configuration (ports C1C2-D1D2 open), without protective bellow
TYPE: **ES1** CODE: 5SOL519003+XTAP332190
DESCRIPTION: 2 positions control for 6-way configuration (ports D1 e D2 plugged), without protective bellow
TYPE: **ES2** CODE: 5SOL519003+XTAP332190
DESCRIPTION: 2 positions control for 6-way configuration (ports C1 e C2 plugged), without protective bellow

5 Antishock valves **page 121**

With fixed setting: setting is referred to valve opening

TYPE	CODE	DESCRIPTION
P(D2-80)	X005125095	Setting 80 bar (1150 psi)
P(D2-110)	X005125110	Setting 110 bar (1590 psi)
P(D3-125)	X005125145	Setting 125 bar (1800 psi)
P(D3-140)	X005125155	Setting 140 bar (2050 psi)
P(D3-170)	X005125190	Setting 170 bar (2450 psi)
P(D4-185)	X005125216	Setting 185 bar (2700 psi)
P(D4-210)	X005125245	Setting 210 bar (3050 psi)
P(D4-240)	X005125270	Setting 240 bar (3500 psi)
P1T - P2T	3XTAP524290	Blanking plug P1-P2

6 Plug for ES1 - ES2 controls

TYPE	CODE	DESCRIPTION
-	3XTAP727180	G1/2 Plug for ES1-ES2 execution

7 Coil

For list of available coils see pages 122

8 Body threading

Specify threading always when it is different from **BSP** standard

9 Accessories

For list of available connectors see pages 122

(*) - Codes are referred to **BSP** thread

Spool circuits

Type B

8 way configuration (ES3)

A1↔B1, A2↔B2 and
D1, D2, C1, C2 ports closed in pos. 0

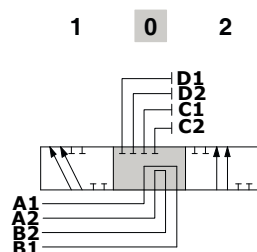

Spool stroke

Position 1: + 5.8 mm (0.23 in)
Position 2: - 5.8 mm (- 0.23 in)

6 way configuration (ES1)

A1↔D1, A2↔D2 and
B1, B2, C1, C2 ports closed in pos. 1

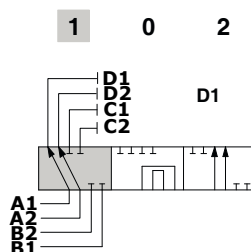

Spool stroke

Position 2: - 5.8 mm (- 0.23 in)

6 way configuration (ES2)

A1↔C1, A2↔C2 and
D1, D2, B1, B2 ports closed in pos. 2

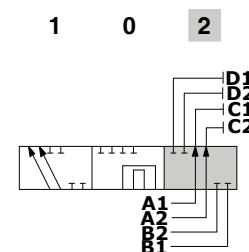

Spool stroke

Position 1: + 5.8 mm (0.23 in)

ES control kit

With spring return in position 0

Tipo 8ES2

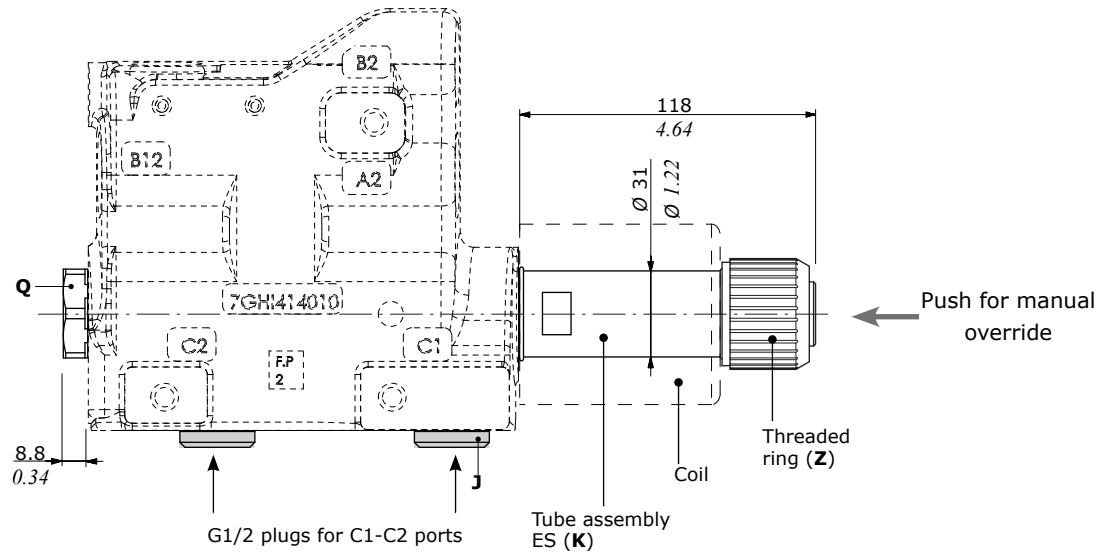
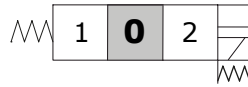

Wrenches and tightening torque

J = wrench 8 - 24 Nm (17.7 lbf^t)

K = wrench 27 - 24 Nm (17.7 lbf^t)

Z = 24 Nm (17.7 lbf^t)

Q = wrench 32 - 42 Nm (31 lbf^t)

Tipo 8ES1

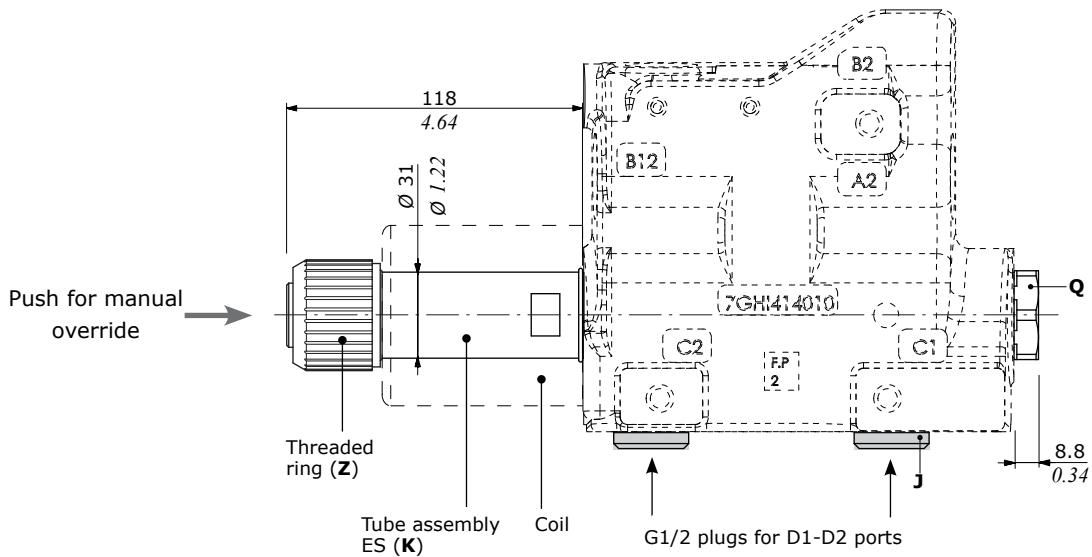
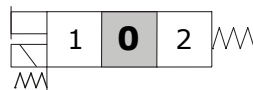

With spring return in position 0

Tipo 8ES3

Wrenches and tightening torque

- J** = wrench 8 - 24 Nm (17.7 lbf^t)
- K** = wrench 27 - 24 Nm (17.7 lbf^t)
- Z** = 24 Nm (17.7 lbf^t)
- Q** = wrench 32 - 42 Nm (31 lbf^t)

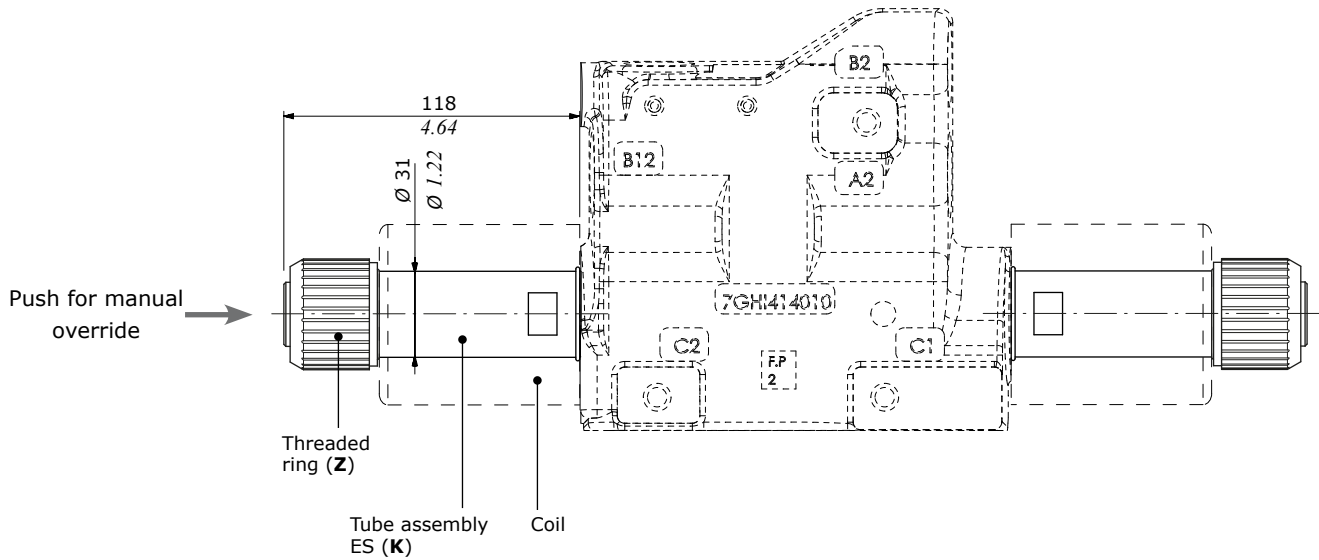
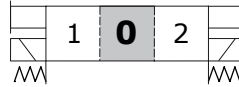

Antishock valves

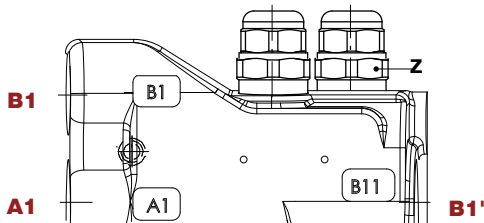

Configuration with valve on each workport (P3)

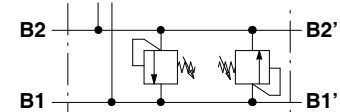

Wrenches and tightening torque

- Z** = wrench 27 - 42 Nm (31 lbf^t)

Antishock valves performance data

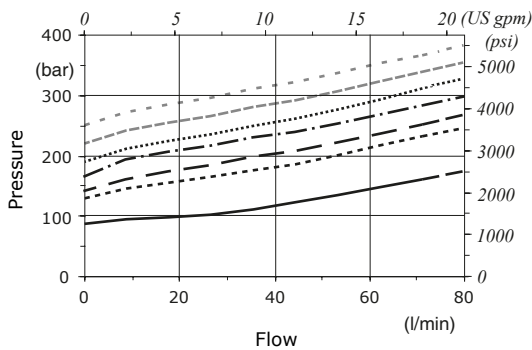

Configuration with valve on workport B1 (P1)

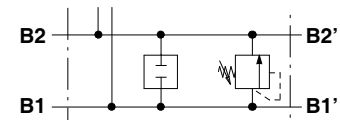

Configuration with valve on workport B2 (P2)

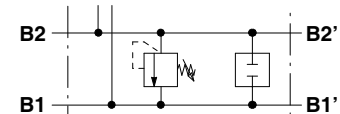

Coils and accessories

		Ordering codes					
Type	Voltage	Connector types					Flying leads without connector
		ISO4400	Deutsch DT	AMP JPT	Packard Weatherpack	Packard Metri-pack	
D19	12 VDC	4SOL519112	4SOL519402 ⁽⁶⁾	-	-	-	-
	20 VDC	4SOL519120	-	-	-	-	-
	24 VDC	4SOL519124	4SOL519404 ⁽⁶⁾	-	-	-	-
	94 VDC	4SOL519194	-	-	-	-	-
	192 VDC	4SOL519292	-	-	-	-	-
Mating connectors		4CN1009995	5CON140031	-	-	-	-

Notes: ⁽¹⁾ supply with AC and use only with rectifier connector - ⁽²⁾ with flying leads - ⁽³⁾ with bidirectional diode - ⁽⁴⁾ with unidirectional diode - ⁽⁵⁾ integrated perpendicular type - ⁽⁶⁾ integrated parallel type

Features

Nominal voltage tolerance: $\pm 10\%$
 Nominal power.....: 60 W
 12/20/24/94/192 VDC
 Nominal current.....: 5 A @ 12 VDC
 : 3 A @ 20 VDC
 : 2.5 A @ 24 VDC
 : 2.5 A @ 94 VDC
 : 0.31 A @ 192 VDC
 Insulation.....: Class H (180°C - 356 °F)
 Weather protection.....: IP65 - ISO4400
 : IP69K - Deutsch DT
 Insertion.....: 100%

ISO4400 connector

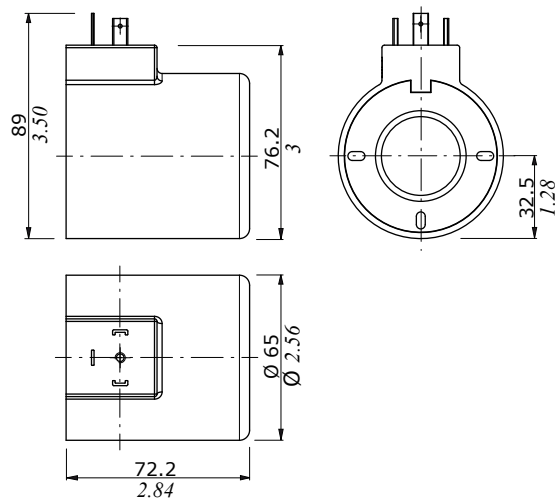

DEUTSCH DT04 connector (Parallel type)

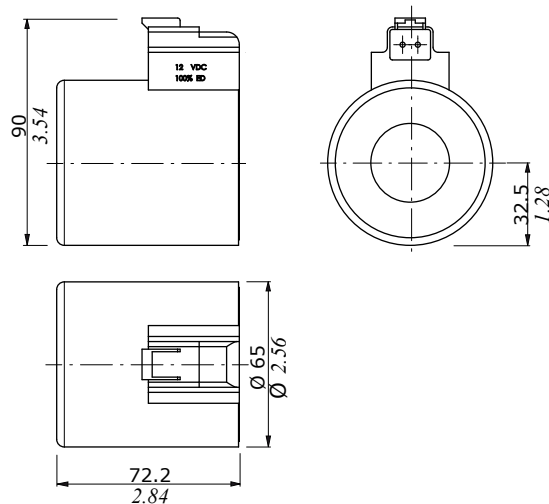



DFE080

Solenoid control sectional diverter valves

- 6 - 8 - 10 ways configuration
- Galvanized body

This catalogue shows technical specifications and diagrams measured with mineral oil of 46 mm²/s (46 cSt) viscosity at 40°C - (104°F) temperature.

WORKING CONDITIONS		
N. of available ways		6 - 8 - 10
Max. flow rating		25 l/min (6.6 US gpm)
Max. pressure	without drain	200 bar (2900 psi)
	with drain	315 bar (4600 psi)
Available supply voltage	VDC	see reference page 130
Nominal power		38 W
Internal leakage A(B)⇒T	Δp = 100 bar (1450 psi)	7 cm ³ /min (0.42 in ³ /min)
Fluid		Mineral based oil
Tie rod tightening		9.8 Nm (7.22 lbft)
Fluid temperature	with NBR (BUNA-N) seals	from -20°C to 80°C (from -4°F to 176°F)
	with FPM (VITON) seals	from -20°C to 100°C (from -4°F to 212°F)
Viscosity	operating range	from 15 to 75 mm ² /s (from 15 to 75 cSt)
	min.	12 mm ² /s (12 cSt)
	max.	400 mm ² /s (400 cSt)
Max. level of contamination		20/18/15 - ISO 4406 - NAS 1638 - class 9
Ambient temperature for working conditions		from -20°C to 50°C (from -4°F to 122°F)

NOTE - For different working conditions please contact Sales Dept.

Available threads

PORTS THREAD		
ALL PORTS	BSP	UN-UNF
DFE080	G 1/4	7/16-20 (SAE 4)
PILOT PORTS		
L	G 1/4	7/16-20 (SAE 4)

Dimensional data - hydraulic circuit - performance data

6 ways

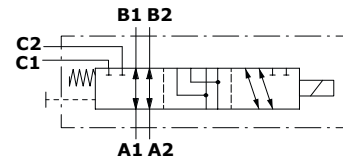
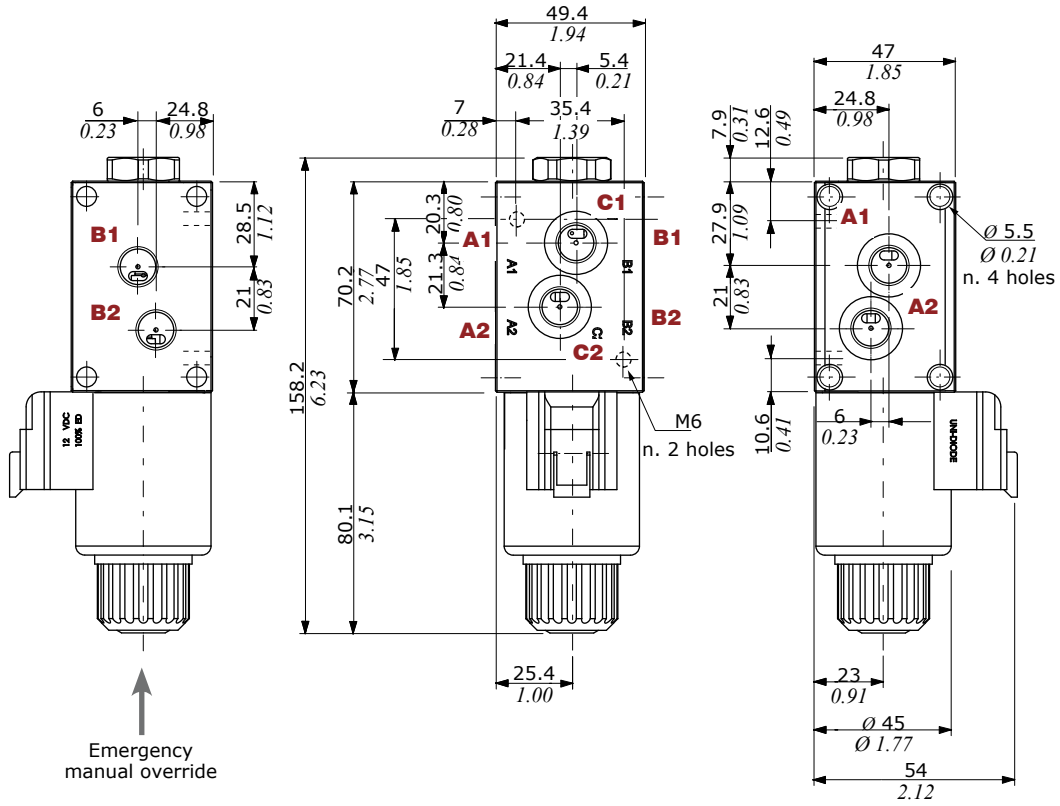

Pressure drop versus flow

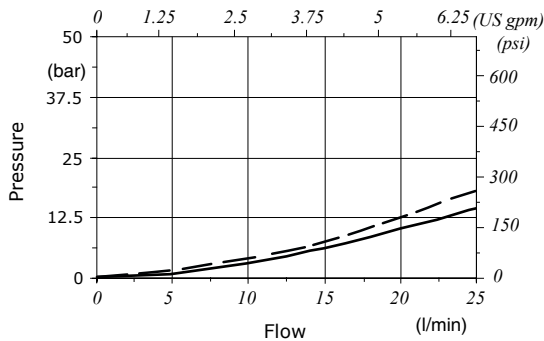

— A1 → B1
 - - A1 → C1

Minimum dynamic conditions

(Supply = Vn-10%, coil at 70 °C - 158 °F)

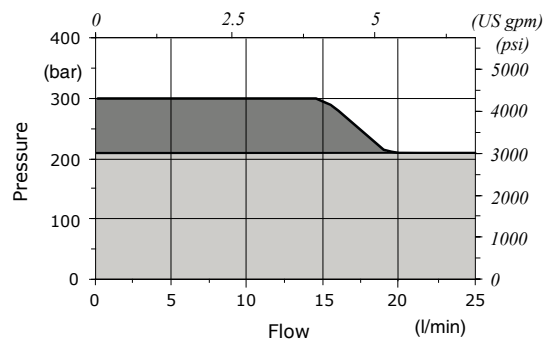

■ With drain
 ■ Without drain

Dimensional data - hydraulic circuit - performance data

8 ways

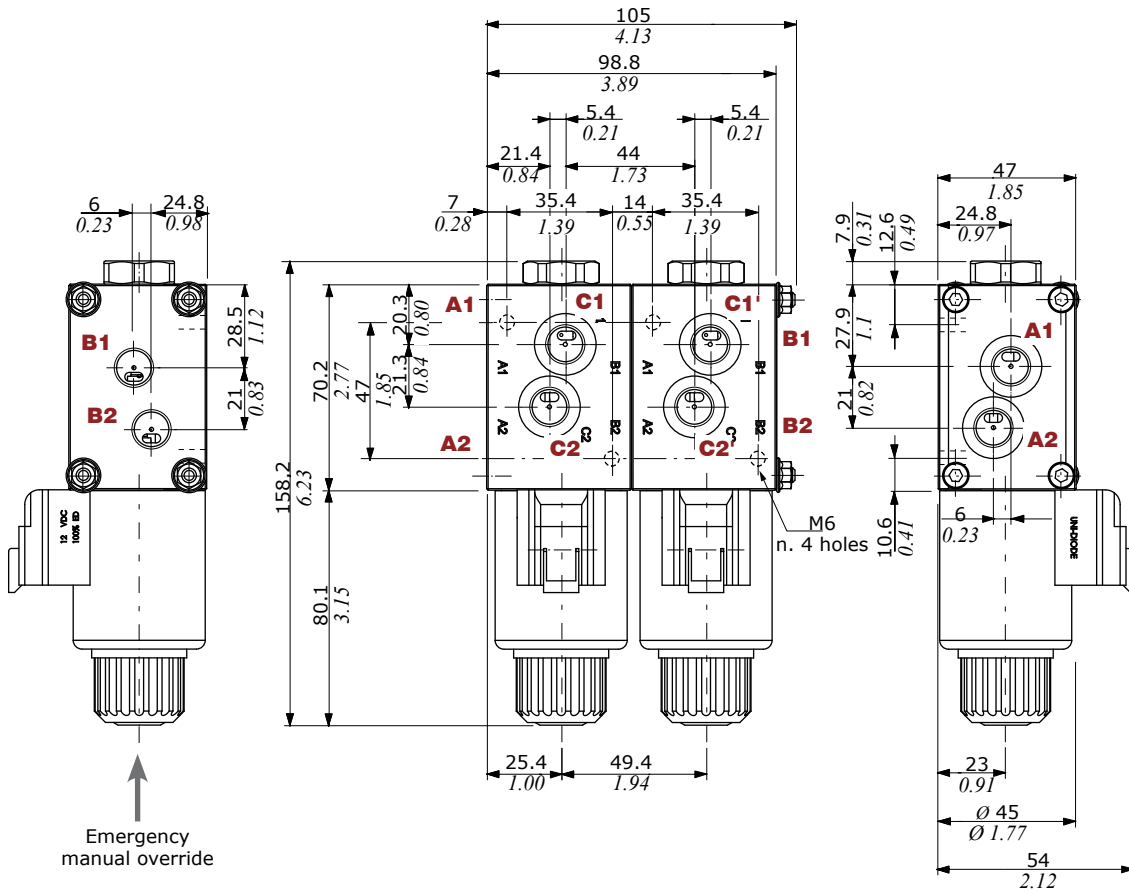

Pressure drop versus flow

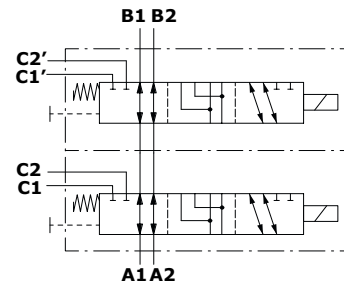
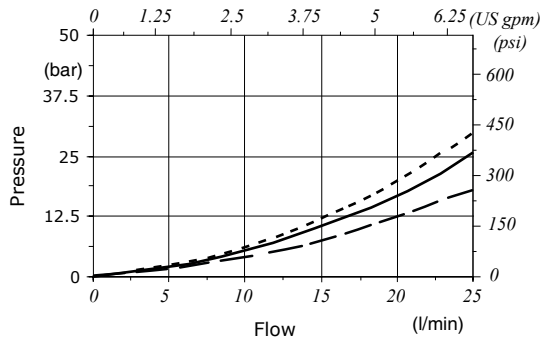

- A1 → B1'
- A1 → C1'
- - - A1 → C1

Dimensional data - hydraulic circuit - performance data

10 ways

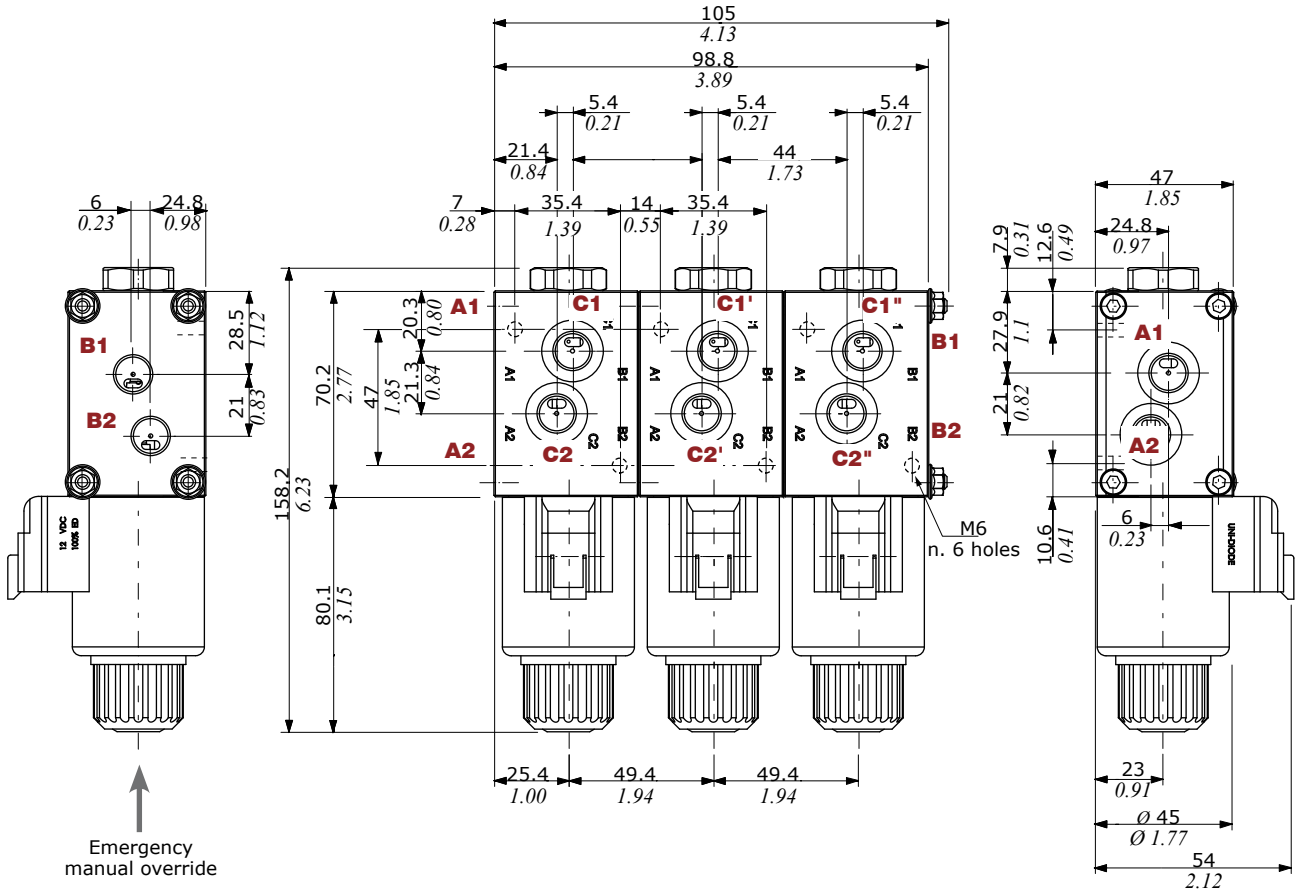

Perdite di carico in funzione alla portata

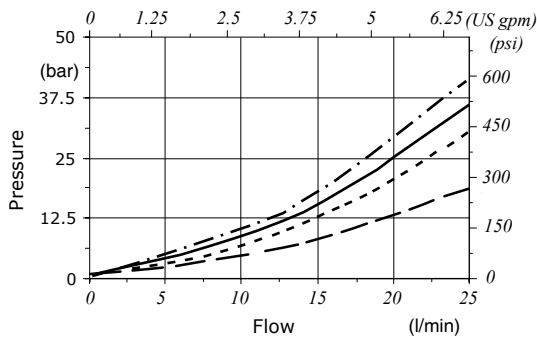

— A1 → B1'' ····· A1 → C1'
 - - - A1 → C1 - · - · - A1 → C1''

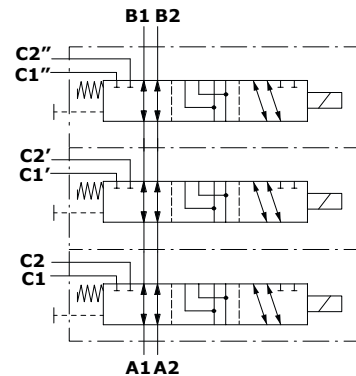

Part ordering codes

Example:

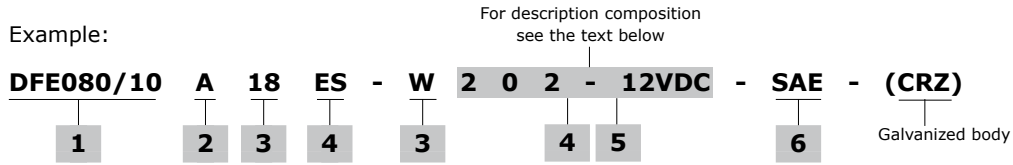

- Coil**
1 = without coil
2 = with coil
- Connection***
0 = ISO (Std)
2 = AMP-JPT
3 = Deutsch DT06
4 = Deutsch DT04-2P Male
5 = Deutsch DT04-4P Female
6 = Metri-Pack Female
7 = Metri-Pack Male
8 = WeatherPack Male
9 = WeatherPack Female
- Lenght cables**
(only if it's present)
Lenght is in mm
- Diode***
(text omitted if diode is not present)
DB = bidirectional diode
- Bellow**
1 = without bellow
2 = with bellow
- Coil voltage**
- (*) - For diodes and connector options see coils table on page 130

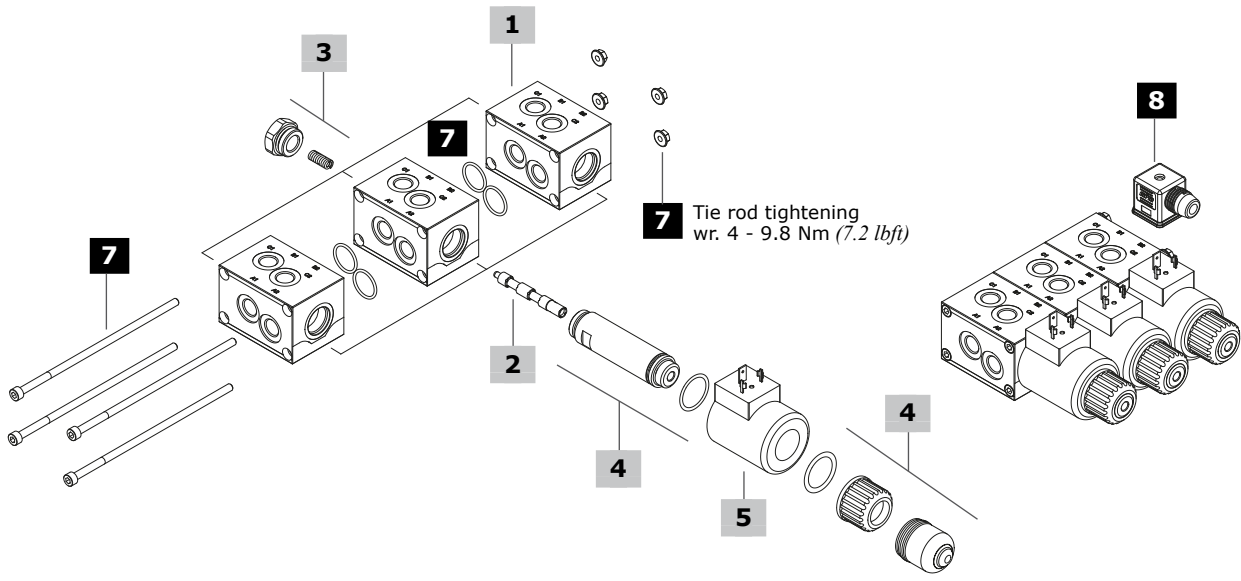

1 Body kit*		
TYPE	CODE	DESCRIPTION
DFE080/6-8-10	3C02208720	6 ways body kit

2 Spools		
TYPE	CODE	DESCRIPTION
A	3CAS108640	A1/A2 in B1/B2 in pos. 1. A1/A2 in C1/C2 in pos. 2. Ports connected in transit position
B	3CAS108740	A1/A2 in B1/B2 in pos. 1. A1/A2 in C1/C2 in pos. 2. Ports closed in transit position
H	3CAS108840	A1/A2 in B1/B2 in pos. 1. A1/A2 in C1/C2 in pos. 2. Port connected to drain in transit position
N	3CAS108940	As type A, for right inlet

3 Positioner kit		
TYPE	CODE	DESCRIPTION
18...W	5TAP007	Spring return in pos. 1
18...Y	5GIU015*	Spring return in pos. 1, with SAE4 drain port

4 Solenoid kit		
TYPE	CODE	DESCRIPTION
ES	5SOL515000	Tube assembly without protective bellow
-	4ACC515	Optional assembly tube protective bellow

5 Coil		
For list of available coils see pages 130		

6 Body threading		
Specify threading always when it is different from BSP standard		

7 Tie rods kit and O-ring seals		
CODE	DESCRIPTION	
5TIR080008	For DFE080/8 diverter valves	
5TIR080010	For DFE080/10 diverter valves	

8 Accessories		
For list of available connectors see pages 130		

(*) - Codes are referred to **UN-UNF** thread

Spool circuits

Type A

A1/A2 in B1/B2 in pos. 1.
Ports connected in transit position

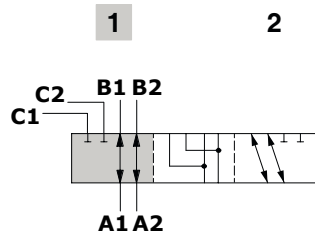

Spool stroke

Position 2: + 3.2 mm (0.12 in)

Type B

A1/A2 in B1/B2 in pos. 1.
Ports closed in transit position

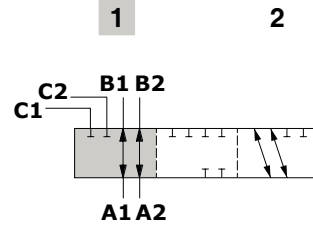

Spool stroke

Position 2: + 3.2 mm (0.12 in)

Type H

A1/A2 in B1/B2 in pos. 1.
Port connected to drain in transit position

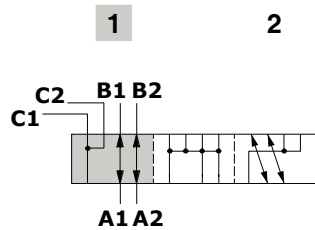

Spool stroke

Position 2: + 3.2 mm (0.12 in)

Type N

As type A, for right inlet

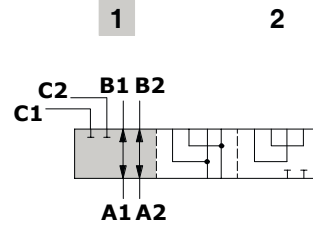

Spool stroke

Position 2: + 3.2 mm (0.12 in)

Positioner kit

With spring return in position 1

Type 18W
With plug



Type 18Y
With SAE4 drain port



Wrenches and tightening torque
Z = wrench 24 - 42 Nm (31 lbft)

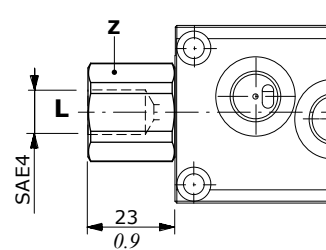
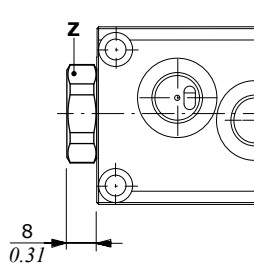

Solenoid kit

ES tube assembly kit

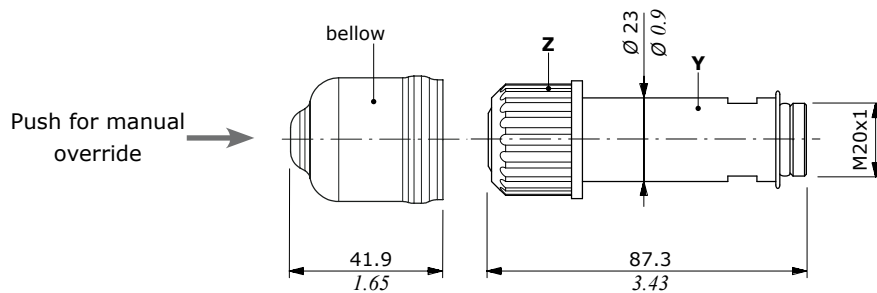

Wrenches and tightening torque
Y = wrench 20 - 24 Nm (17.7 lbft)
Z = 24 Nm (17.7 lbft)

Coils and accessories

Type	Voltage	Ordering codes					
		ISO4400	Deutsch DT	AMP JPT	Packard Weatherpack	Packard Metri-pack	Flying leads without connector
D15	12 VDC	4SOL515012	4SOL515011 ⁽²⁾ 4SOL515014A ⁽³⁻⁶⁾	4SOL515016 ⁽⁵⁾	-	-	-
	14 VDC	-	4SOL515014B ⁽³⁻⁶⁾	4SOL515016A ⁽⁵⁾	-	-	-
	24 VDC	4SOL515024	4SOL515025A ⁽³⁻⁶⁾ 4SOL515021 ⁽²⁾	-	-	-	-
	48 VDC	4SOL515048	-	4SOL515049 ⁽²⁾	-	-	-
	98 VDC	4SOL515098	-	-	-	-	-
	110 VDC	4SOL515110	-	-	-	-	-
Mating connectors		4CN100995	5CON140031	5CON003	-	-	-

Notes: ⁽¹⁾ supply with AC and use only with rectifier connector - ⁽²⁾ with flying leads - ⁽³⁾ with bidirectional diode - ⁽⁴⁾ with unidirectional diode - ⁽⁵⁾ integrated perpendicular type - ⁽⁶⁾ integrated parallel type

Features

Nominal voltage tolerance: ±10%
 Nominal power.....: 38 W
 12/14/24/48/98/110 VDC
 Nominal current.....: 3.16 A @ 12 VDC
 : 2.9 A @ 14 VDC
 : 1.58 A @ 24 VDC
 : 0.79 A @ 48 VDC
 : 0.41 A @ 98 VDC
 : 0.35 A @ 110 VDC
 Insulation.....: Class H (180°C - 356°F)
 Weather protection.....: IP65 - ISO4400
 : IP69K - Deutsch DT
 : IP65 - AMP JPT
 Insertion.....: 100%

ISO4400 connector

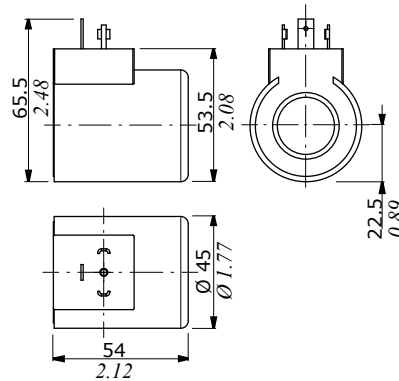

Flying leads with DEUTSCH DT04 connector

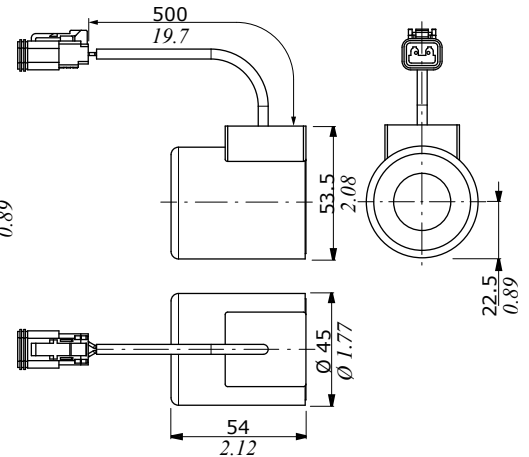

DEUTSCH DT04 connector (Parallel type)

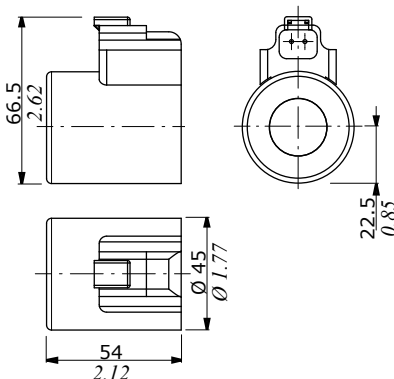

AMP JPT connector (Perpendicular type)

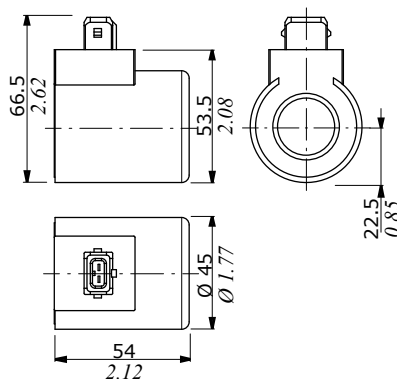

Flying leads with AMP JPT connector

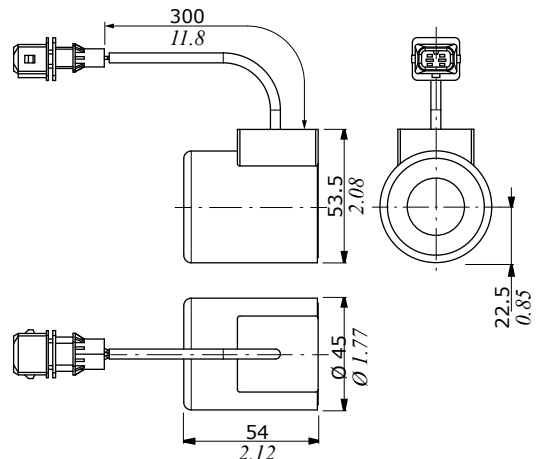



DFE100

Solenoid control sectional diverter valves

- 6 - 8 - 10 ways configuration
- Galvanized body

This catalogue shows technical specifications and diagrams measured with mineral oil of 46 mm²/s (46 cSt) viscosity at 40°C - (104°F) temperature.

WORKING CONDITIONS		
N. of available ways		6 - 8 - 10
Max. flow rating		50 l/min (13.2 US gpm)
Max. pressure	without drain	200 bar (2900 psi)
	with drain	315 bar (4600 psi)
Available supply voltage	VDC	see reference page 138
Nominal power		38 W
Internal leakage A(B)⇒T	Δp = 100 bar (1450 psi)	10 cm ³ /min (0.61 in ³ /min)
Fluid		Mineral based oil
Tie rod tightening		18 Nm (13.3 lbft)
Fluid temperature	with NBR (BUNA-N) seals	from -20°C to 80°C (from -4°F to 176°F)
	with FPM (VITON) seals	from -20°C to 100°C (from -4°F to 212°F)
Viscosity	operating range	from 15 to 75 mm ² /s (from 15 to 75 cSt)
	min.	12 mm ² /s (12 cSt)
	max.	400 mm ² /s (400 cSt)
Max. level of contamination		20/18/15 - ISO 4406 - NAS 1638 - class 9
Ambient temperature for working conditions		from -20°C to 50°C (from -4°F to 122°F)

NOTE - For different working conditions please contact Sales Dept.

Available threads

PORTS THREAD				
ALL PORTS	BSP	UN-UNF	METRIC* (ISO 9974-1)	METRIC* (ISO 6149)
DFE100	G 3/8	3/4-16 (SAE 8)	M18x1.5	M18x1.5
PILOT PORTS				
L	G 1/4	9/16-18 (SAE 6)	M12x1.5	M12x1.5

(*) Optional threads
for availability contact Sales
Department

Dimensional data - hydraulic circuit - performance data

6 ways

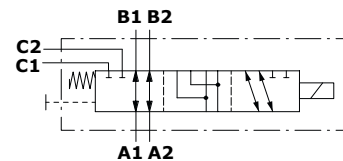
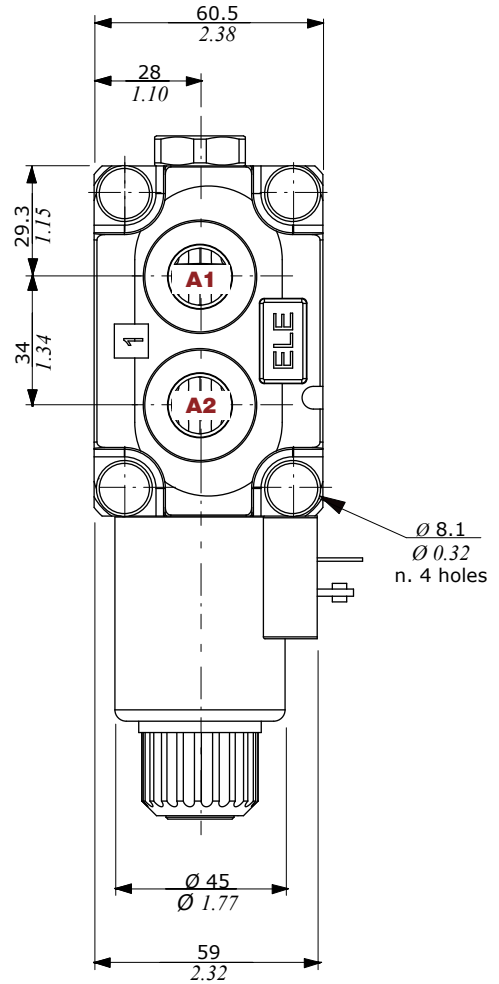
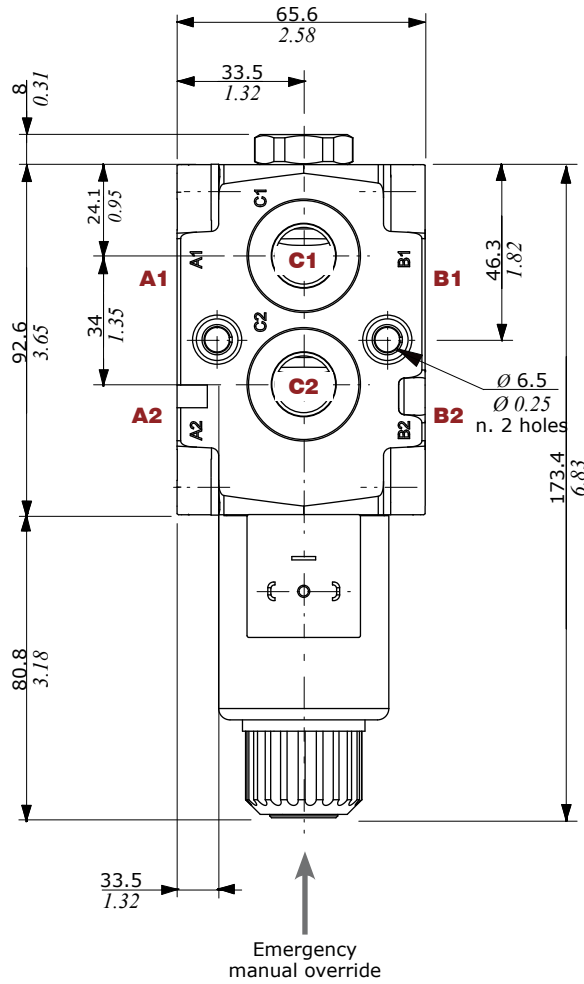

Pressure drop versus flow

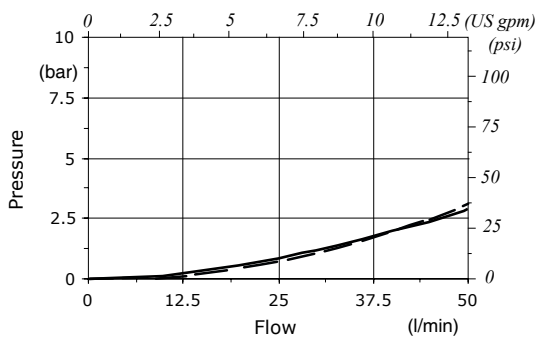

— A1 → B1
 - - A1 → C1

Minimum dynamic conditions

(Supply = Vn-10%, coil at 70 °C - 158 °F)

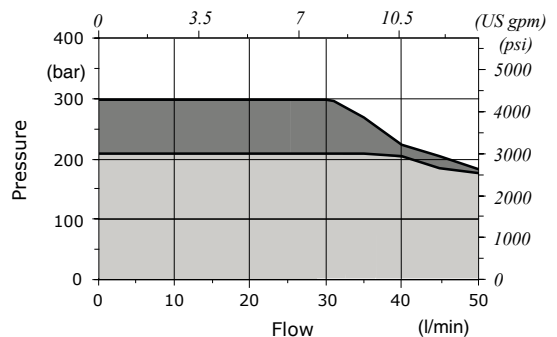

■ With drain
 ■ Without drain

Dimensional data - hydraulic circuit - performance data

10 ways

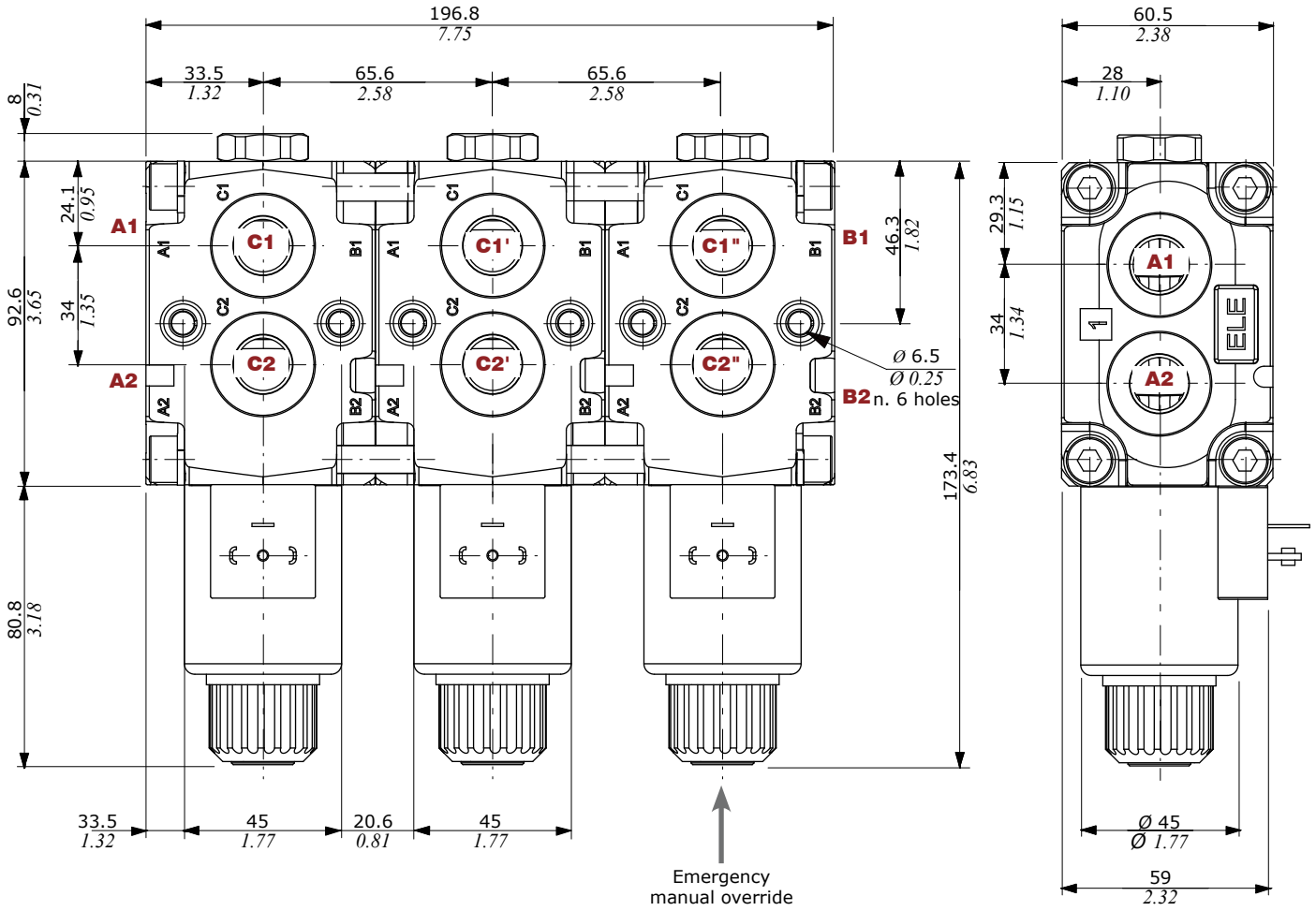

Pressure drop versus flow

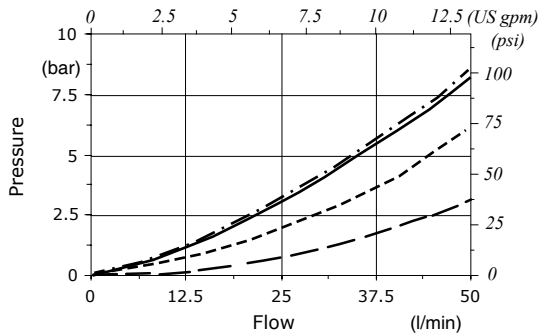

- A1 → B1'' ····· A1 → C1'
- - - A1 → C1 - · - · - A1 → C1''

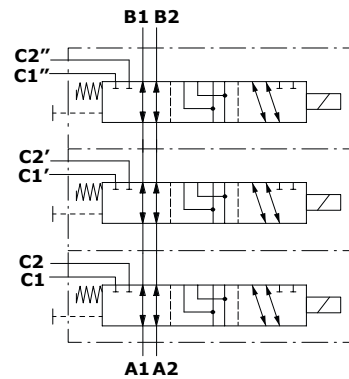

Part ordering codes

Example:

For description composition see the text below

DFE100/10 A 18 ES - W 2 0 2 - 12VDC - SAE - (CRZ)

1 2 3 4 3 4 5 6 Galvanized body

Coil
1 = without coil
2 = with coil

Connection*
0 = ISO (Std)
2 = AMP-JPT
3 = Deutsch DT06
4 = Deutsch DT04-2P Male
5 = Deutsch DT04-4P Female
6 = Metri-Pack Female
7 = Metri-Pack Male
8 = WeatherPack Male
9 = WeatherPack Female

Lenght cables
(only if it's present)
Lenght is in mm

Diode*
(text omitted if diode is not present)
DB = bidirectional diode

Bellow
1 = without bellow
2 = with bellow

Coil voltage

(*) - For diodes and connector options see coils table on page 138

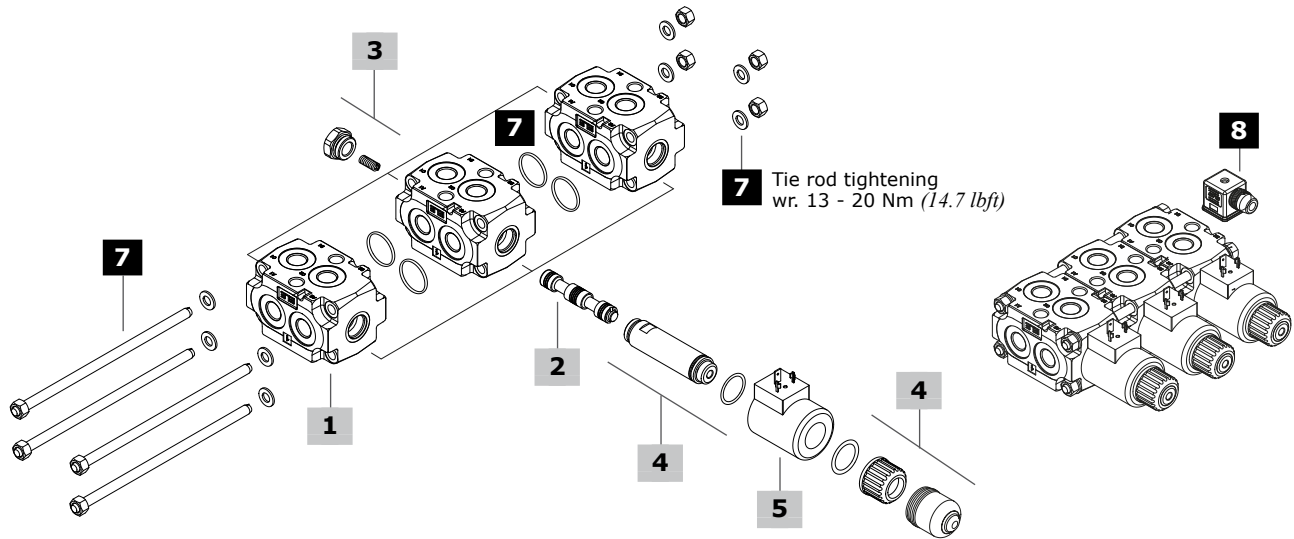

1 Body kit*

TYPE	CODE	DESCRIPTION
DFE100/6-8-10	3CO2244721	6 ways body kit

2 Spools **page 136**

TYPE	CODE	DESCRIPTION
A	3CAS110647	A1/A2 in B1/B2 in pos. 1. A1/A2 in C1/C2 in pos. 2. Ports connected in transit position
B	3CAS110747	A1/A2 in B1/B2 in pos. 1. A1/A2 in C1/C2 in pos. 2. Ports closed in transit position
H	3CAS110847	A1/A2 in B1/B2 in pos. 1. A1/A2 in C1/C2 in pos. 2. Port connected to drain in transit position
N	3CAS110947	As type A, for right inlet

3 Positioner kit **page 137**

TYPE	CODE	DESCRIPTION
18...W	5TAP006	Spring return in pos. 1
18...Y	5GIU014*	Spring return in pos. 1, with SAE6 drain port

4 Solenoid kit **page 137**

TYPE	CODE	DESCRIPTION
ES	5SOL515000	Tube assembly without protective bellow
-	4ACC515	Optional assembly tube protective bellow

5 Coil

For list of available coils see pages 138

6 Body threading

Specify threading always when it is different from **BSP** standard

7 Tie rods kit and O-ring seals

CODE	DESCRIPTION
5TIR108132	For DFE100/8 diverter valves
5TIR108198	For DFE100/10 diverter valves

8 Accessories

For list of available connectors see pages 138

(*) - Codes are referred to **UN-UNF** thread

Spool circuits

Type A

A1/A2 in B1/B2 in pos. 1.
Ports connected in transit position

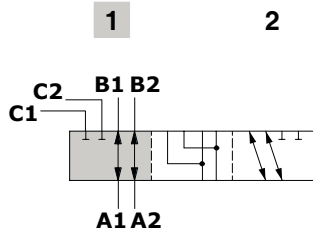

Spool stroke

Position 2: + 4 mm (0.15 in)

Type B

A1/A2 in B1/B2 in pos. 1.
Ports closed in transit position

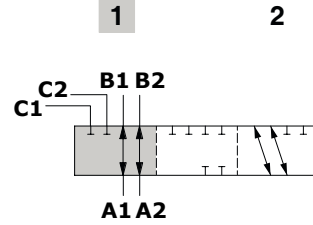

Spool stroke

Position 2: + 4 mm (0.15 in)

Type H

A1/A2 in B1/B2 in pos. 1.
Port connected to drain in transit position

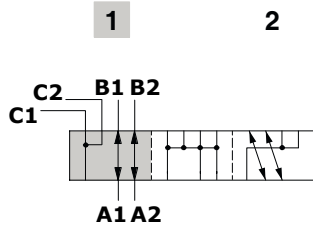

Spool stroke

Position 2: + 4 mm (0.15 in)

Type N

As type A, for right inlet

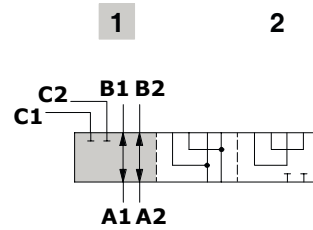

Spool stroke

Position 2: + 4 mm (0.15 in)

Positioner kit

With spring return in position 1

Type 18W
With plug



Type 18Y
With SAE6 drain port



Wrenches and tightening torque
Z = wrench 24 - 42 Nm (31 lbft)

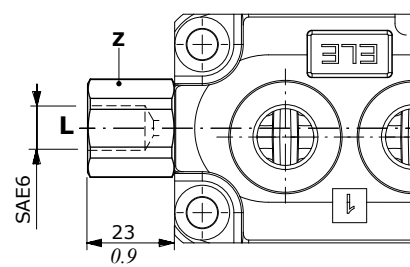
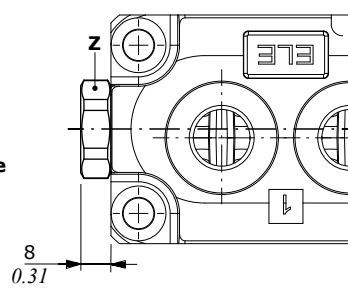

Solenoid kit

ES tube assembly kit

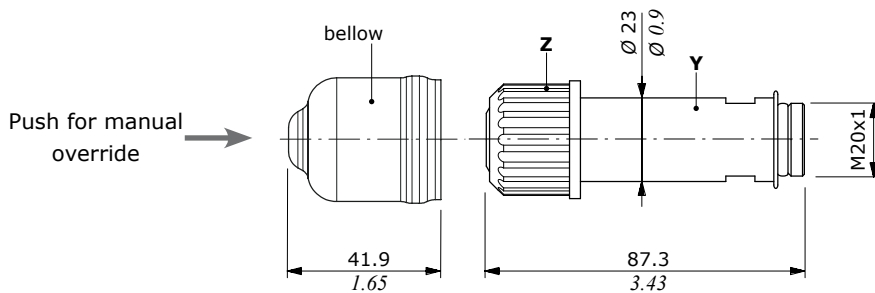

Wrenches and tightening torque
Y = wrench 20 - 24 Nm (17.7 lbft)
Z = 24 Nm (17.7 lbft)

Coils and accessories

Type	Voltage	Ordering codes					
		ISO4400	Deutsch DT	AMP JPT	Packard Weatherpack	Packard Metri-pack	Flying leads without connector
D15	12 VDC	4SOL515012	4SOL515011 ⁽²⁾ 4SOL515014A ⁽³⁻⁶⁾	4SOL515016 ⁽⁵⁾	-	-	-
	14 VDC	-	4SOL515014B ⁽³⁻⁶⁾	4SOL515016A ⁽⁵⁾	-	-	-
	24 VDC	4SOL515024	4SOL515025A ⁽³⁻⁶⁾ 4SOL515021 ⁽²⁾	-	-	-	-
	48 VDC	4SOL515048	-	4SOL515049 ⁽²⁾	-	-	-
	98 VDC	4SOL515098	-	-	-	-	-
	110 VDC	4SOL515110	-	-	-	-	-
Mating connectors		4CN100995	5CON140031	5CON003	-	-	-

Notes: ⁽¹⁾ supply with AC and use only with rectifier connector - ⁽²⁾ with flying leads - ⁽³⁾ with bidirectional diode - ⁽⁴⁾ with unidirectional diode - ⁽⁵⁾ integrated perpendicular type - ⁽⁶⁾ integrated parallel type

Features

Nominal voltage tolerance: ±10%
 Nominal power.....: 38 W
 12/14/24/48/98/110 VDC
 Nominal current.....: 3.16 A @ 12 VDC
 : 2.9 A @ 14 VDC
 : 1.58 A @ 24 VDC
 : 0.79 A @ 48 VDC
 : 0.41 A @ 98 VDC
 : 0.35 A @ 110 VDC
 Insulation.....: Class H (180°C - 356°F)
 Weather protection.....: IP65 - ISO4400
 : IP69K - Deutsch DT
 : IP65 - AMP JPT
 Insertion.....: 100%

ISO4400 connector

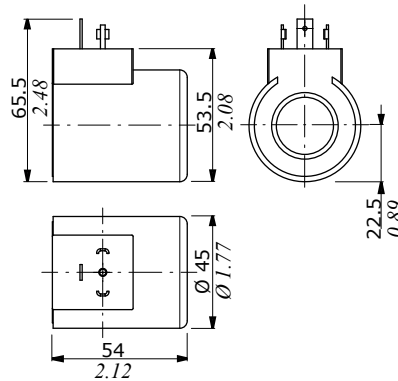

Flying leads with DEUTSCH DT04 connector

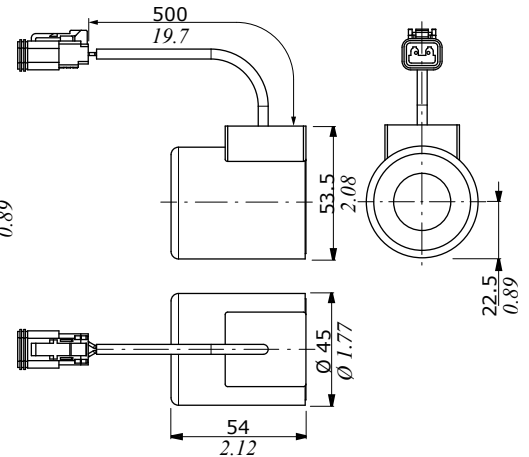

DEUTSCH DT04 connector (Parallel type)

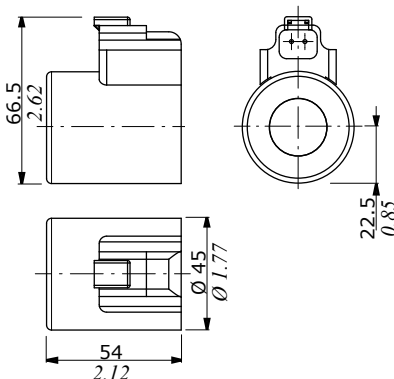

AMP JPT connector (Perpendicular type)

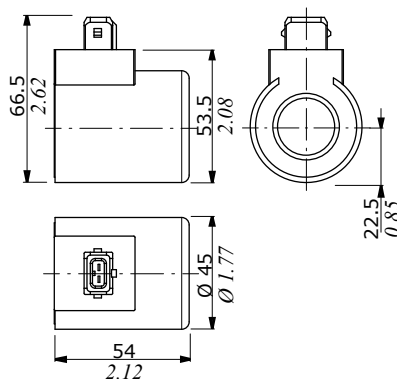

Flying leads with AMP JPT connector

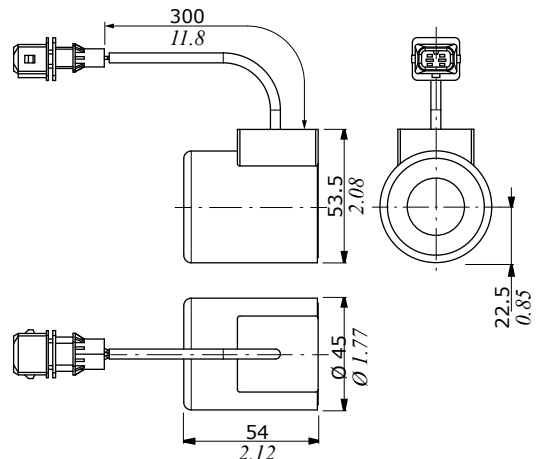



DFE140

Solenoid control sectional diverter valves

- 6 - 8 - 10 ways configuration
- Galvanized body
- Antishock valve block stackable with the diverter valve

This catalogue shows technical specifications and diagrams measured with mineral oil of 46 mm²/s (46 cSt) viscosity at 40°C - (104°F) temperature.

WORKING CONDITIONS		
N. of available ways		6 - 8 - 10
Max. flow rating		80 l/min (21.1 US gpm)
Max. pressure	without drain	200 bar (2900 psi)
	with drain	315 bar (4600 psi)
Available supply voltage	VDC	see reference page 148
Nominal power		60 W
Internal leakage A(B)⇒T	Δp = 100 bar (1450 psi)	10 cm ³ /min (0.61 in ³ /min)
Fluid		Mineral based oil
Tie rod tightening		25 Nm (18.4 lbft)
Fluid temperature	with NBR (BUNA-N) seals	from -20°C to 80°C (from -4°F to 176°F)
	with FPM (VITON) seals	from -20°C to 100°C (from -4°F to 212°F)
Viscosity	operating range	from 15 to 75 mm ² /s (from 15 to 75 cSt)
	min.	12 mm ² /s (12 cSt)
	max.	400 mm ² /s (400 cSt)
Max. level of contamination		20/18/15 - ISO 4406 - NAS 1638 - class 9
Ambient temperature for working conditions		from -20°C to 50°C (from -4°F to 122°F)

NOTE - For different working conditions please contact Sales Dept.

Available threads

PORTS THREAD		
ALL PORTS	BSP	UN-UNF
DFE140	G 1/2	7/8-14 (SAE 10)
PILOT PORTS		
L	G 1/4	9/16-18 (SAE 6)

Dimensional data - hydraulic circuit - performance data

6 ways

The drawing below show diverter valve in 6-way configuration with anti-shock valves block

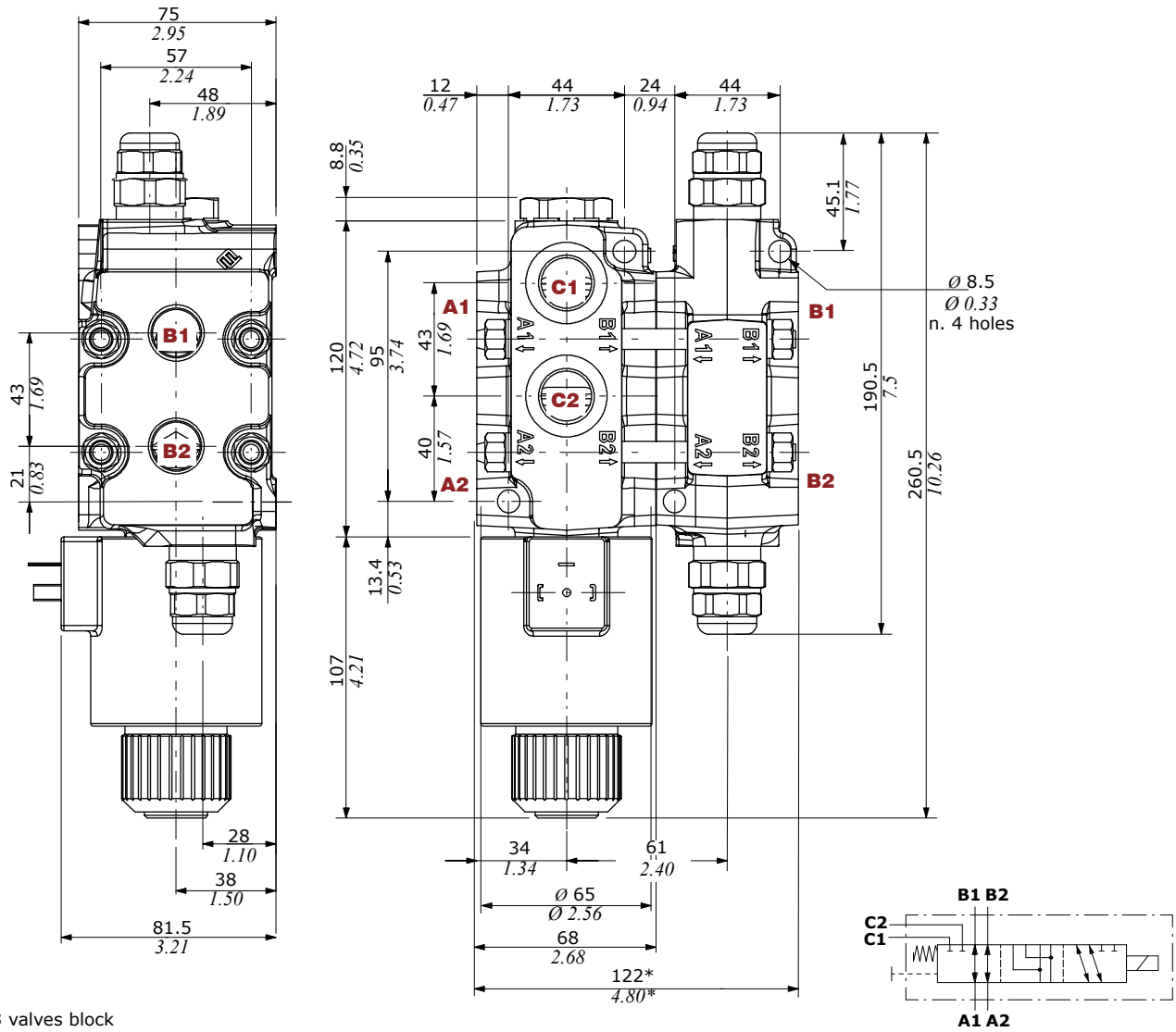

(*) - with P3 valves block

Pressure drop versus flow

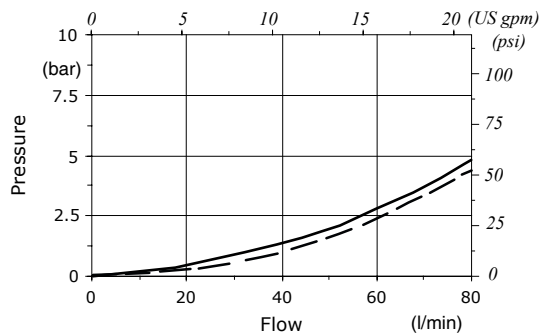

— A1 → B1
 - - - A1 → C1

Minimum dynamic conditions

(Supply = Vn-10%, coil at 70 °C - 158 °F)

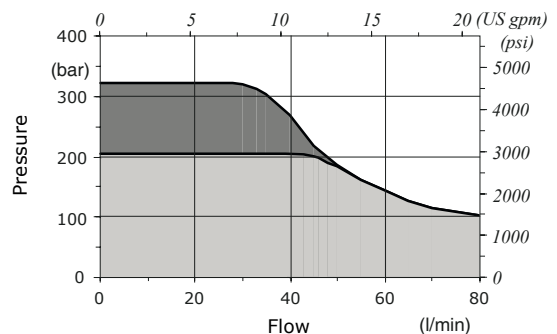

■ With drain
 ■ Without drain

Dimensional data - hydraulic circuit - performance data

8 ways

The drawing below show diverter valve in 8-way configuration with anti-shock valves block

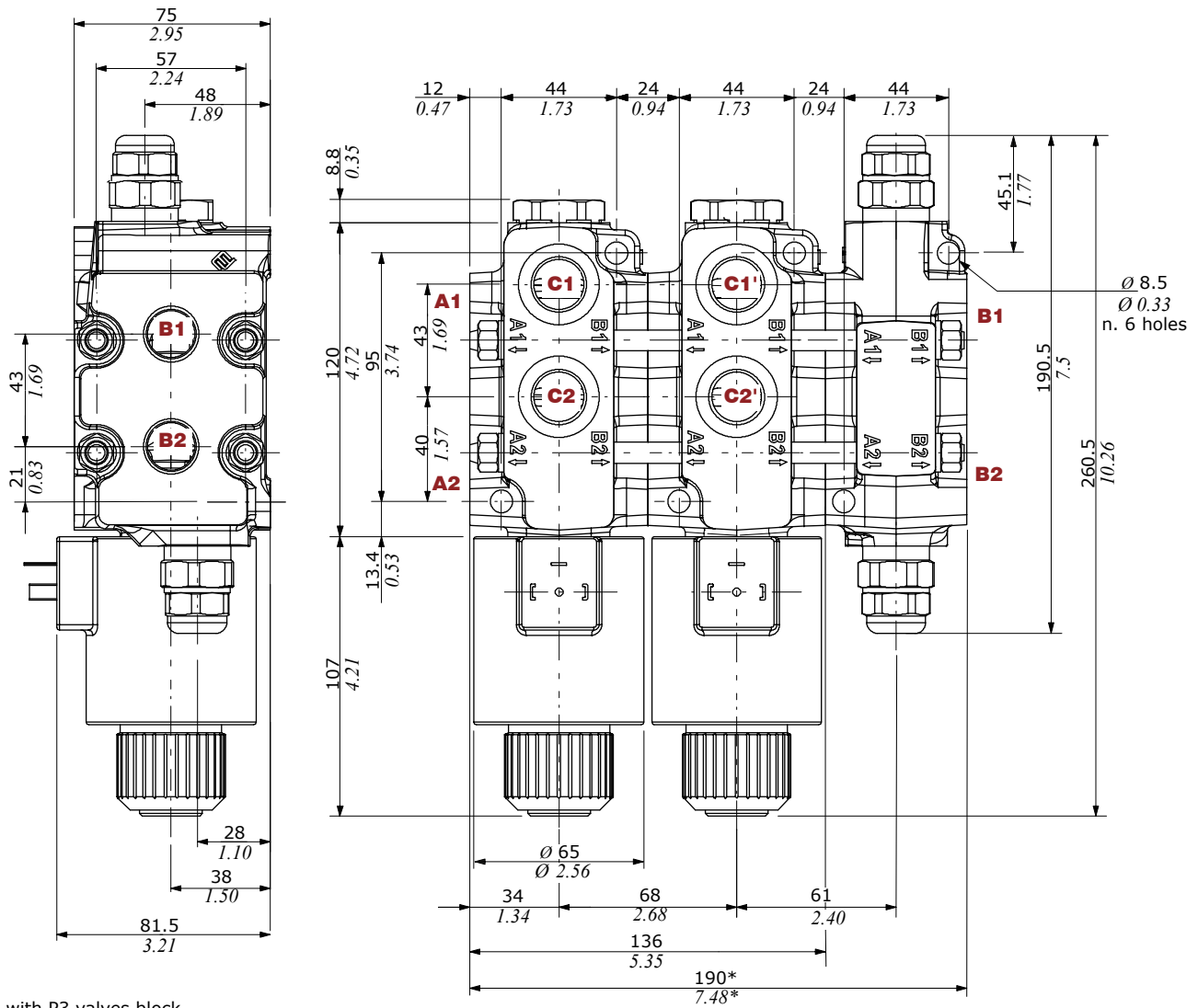

(*) - with P3 valves block

Pressure drop versus flow

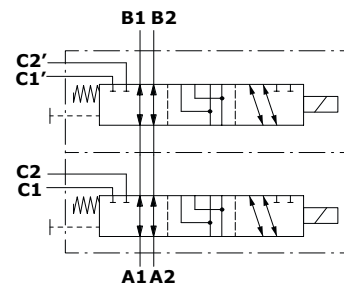
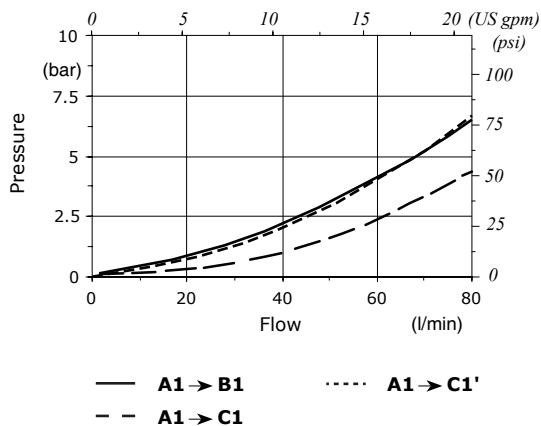

Dimensional data - hydraulic circuit - performance data

10 ways

The drawing below show diverter valve in 10-way configuration with anti-shock valves block

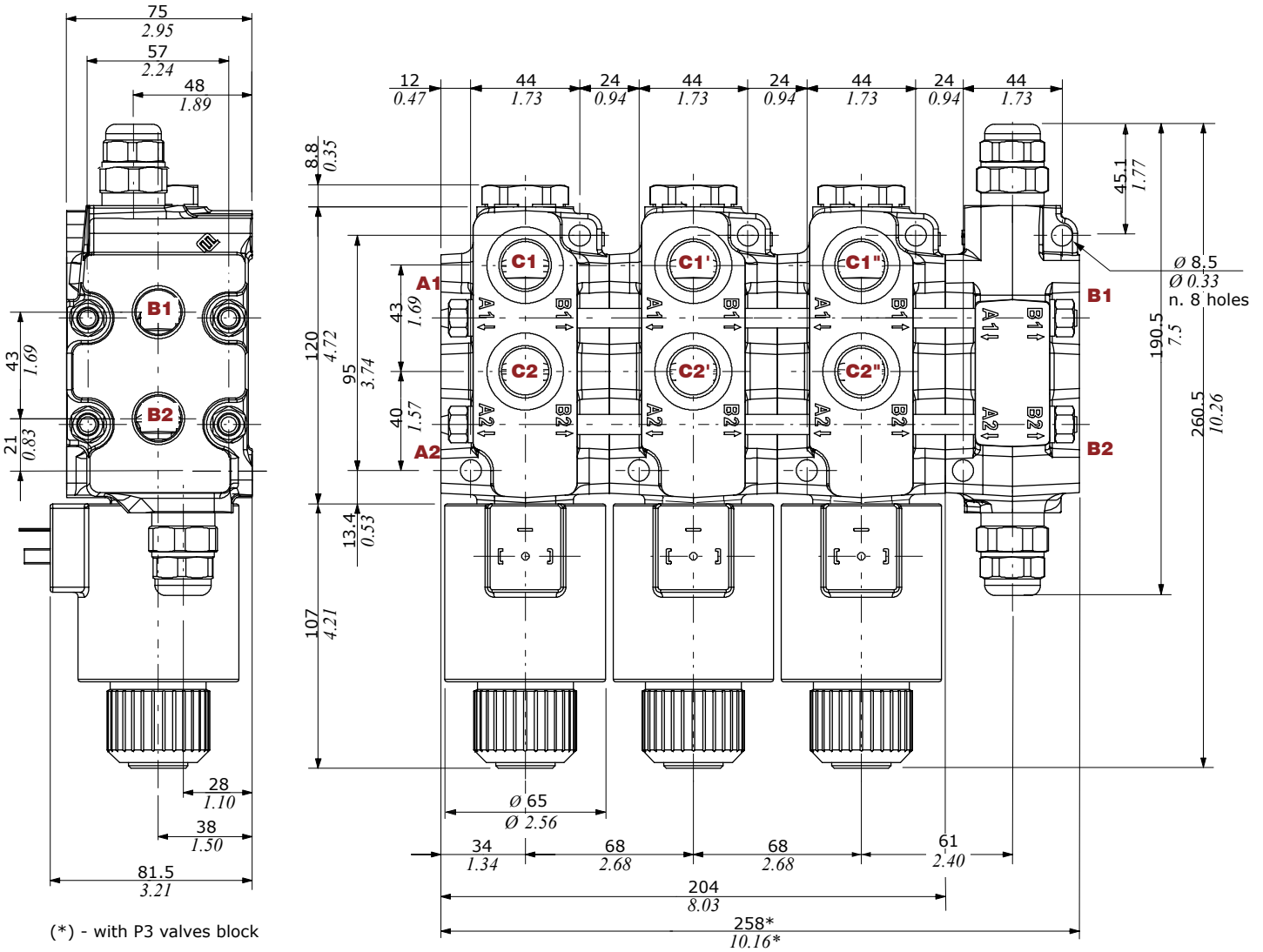

Pressure drop versus flow

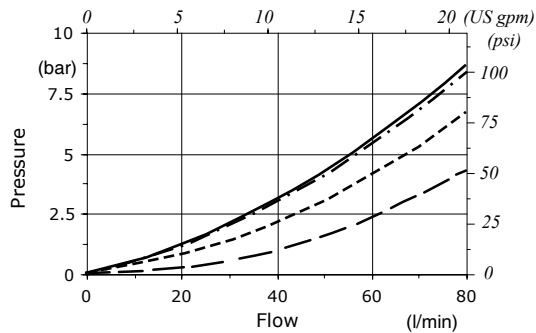

- A1 → B1
- A1 → C1'
- - - A1 → C1
- · - · A1 → C1''

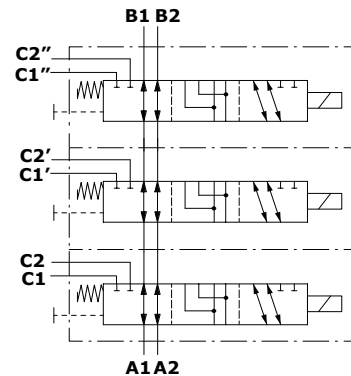

Part ordering codes

Example:

DFE140/8 A 18 ES . P3 (D4-185) - W 2 0 0 - 12VDC - SAE - (CRZ)

1 - on port B
2 - on port A
3 - on port A and B

For description composition see the text below

Galvanized body

Coil
1 = without coil
2 = with coil

Connection*
0 = ISO (Std)
2 = AMP-JPT
3 = Deutsch DT06
4 = Deutsch DT04-2P Male
5 = Deutsch DT04-4P Female
6 = Metri-Pack Female
7 = Metri-Pack Male
8 = WeatherPack Male
9 = WeatherPack Female

Coil voltage
0 = bellow not available

(*) - For connector options see coils table on page 148

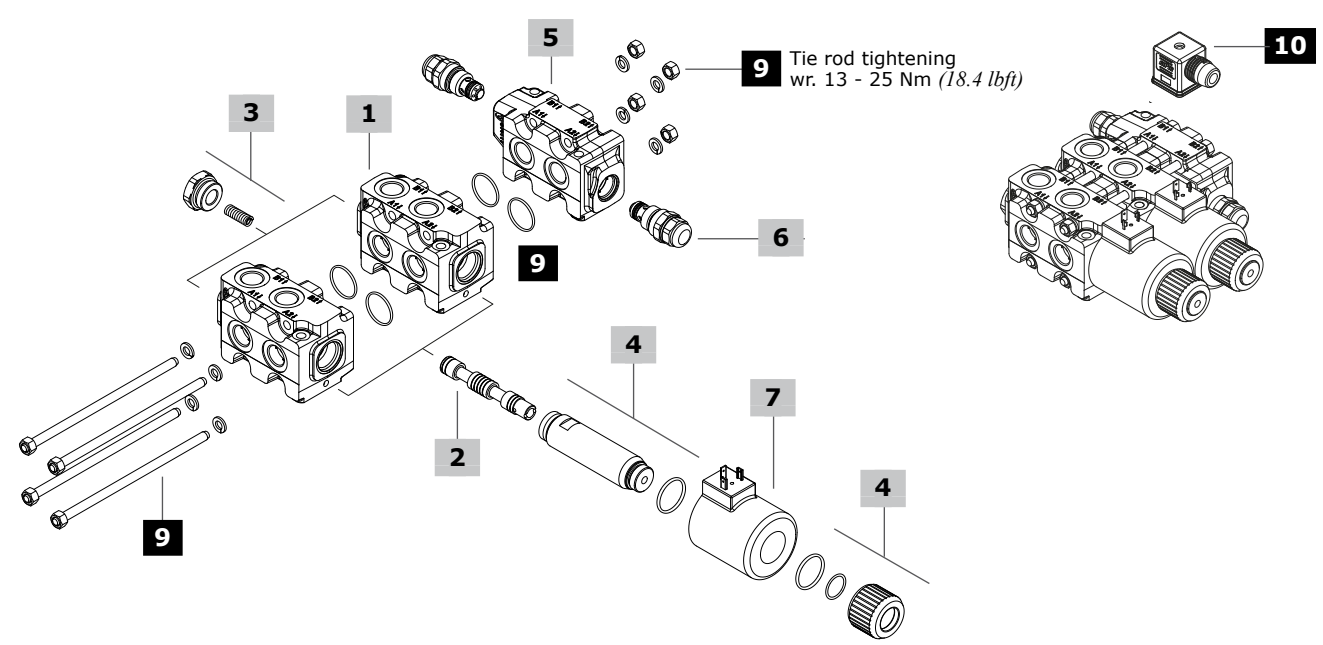

Part ordering codes

1 Body kit*

TYPE	CODE	DESCRIPTION
DFE140/6-8-10	3CO2280703	6 ways body kit

2 Spools page 145

TYPE	CODE	DESCRIPTION
A	3CAS110640	A1/A2 in B1/B2 in pos. 1. A1/A2 in C1/C2 in pos. 2. Ports connected in transit position
B	3CAS110740	A1/A2 in B1/B2 in pos. 1. A1/A2 in C1/C2 in pos. 2. Ports closed in transit position
H	3CAS110845	A1/A2 in B1/B2 in pos. 1. A1/A2 in C1/C2 in pos. 2. Port connected to drain in transit position
N	3CAS110941	As type B, for right inlet

3 Positioner kit page 146

TYPE	CODE	DESCRIPTION
18...W	5TAP005	Spring return in pos. 1
18...Y	5GIU011*	Spring return in pos. 1, with SAE6 drain port

4 Solenoid kit page 146

TYPE	CODE	DESCRIPTION
ES	5SOL519003	Tube assembly without protective bellow

5 Valves block* page 147

TYPE	CODE	DESCRIPTION
P3	3CO2780700	Cross-over antishock valve body

6 Antishock valves page 147

With fixed setting: setting is referred to valve opening

TYPE	CODE	DESCRIPTION
P(D2-80)	X005125095	Setting 80 bar (1150 psi)
P(D2-110)	X005125110	Setting 110 bar (1590 psi)
P(D3-125)	X005125145	Setting 125 bar (1800 psi)
P(D3-140)	X005125155	Setting 140 bar (2050 psi)
P(D3-170)	X005125190	Setting 170 bar (2450 psi)
P(D4-185)	X005125216	Setting 185 bar (2700 psi)
P(D4-210)	X005125245	Setting 210 bar (3050 psi)
P(D4-240)	X005125270	Setting 240 bar (3500 psi)
P1T - P2T	3XTAP524290	Blanking plug P1-P2

7 Coil

For list of available coils see pages 148

8 Body threading

Specify threading always when it is different from **BSP** standard

9 Tie rods kit and O-ring seals

CODE	DESCRIPTION
5TIR108134	For DFE140/8 diverter valves
5TIR108202	For DFE140/10 diverter valves
with valves block:	
5TIR108121	For DFE140/6.P3 diverter valves
5TIR108189	For DFE140/8.P3 diverter valves

10 Accessories

For list of available connectors see pages 148

(*) - Codes are referred to **UN-UNF** thread

Type A

A1/A2 in B1/B2 in pos. 1.
Ports connected in transit position

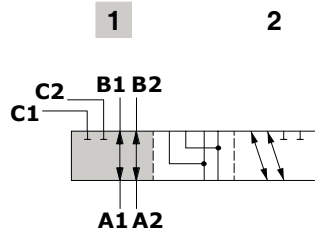

Spool stroke
Position 2: + 5.8 mm (0.22 in)

Type B

A1/A2 in B1/B2 in pos. 1.
Ports closed in transit position

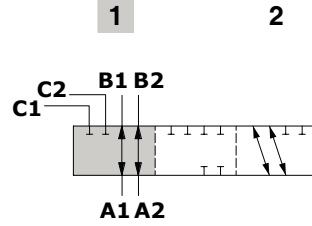

Spool stroke
Position 2: + 5.8 mm (0.22 in)

Type H

A1/A2 in B1/B2 in pos. 1.
Port connected to drain in transit position

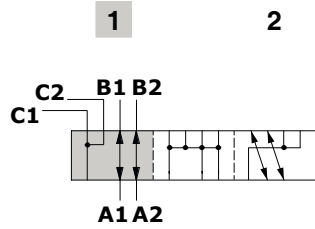

Spool stroke
Position 2: + 5.8 mm (0.22 in)

Type N

As type B, for right inlet

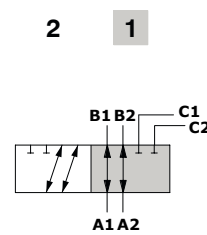

Spool stroke
Position 2: + 5.8 mm (0.22 in)

Positioner kit

With spring return in position 1

Type 18W

With plug

Type 18Y

With SAE6 drain port

Wrenches and tightening torque

Z = wrench 32 - 42 Nm (31 lbft)

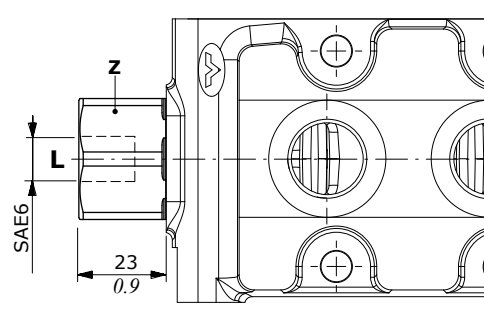
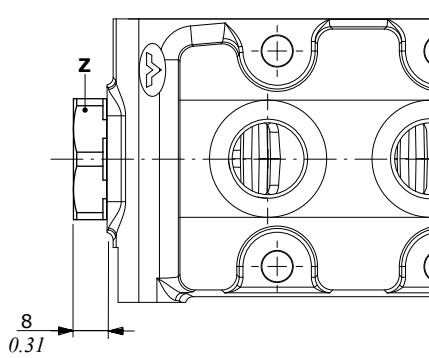

Solenoid kit

ES tube assembly kit

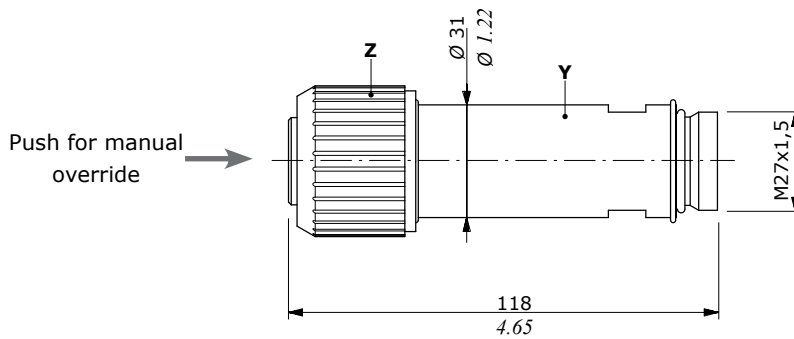

Wrenches and tightening torque

Y = wrench 27 - 24 Nm (17.7 lbft)

Z = 24 Nm (17.7 lbft)

P3 block complete with antishock valves

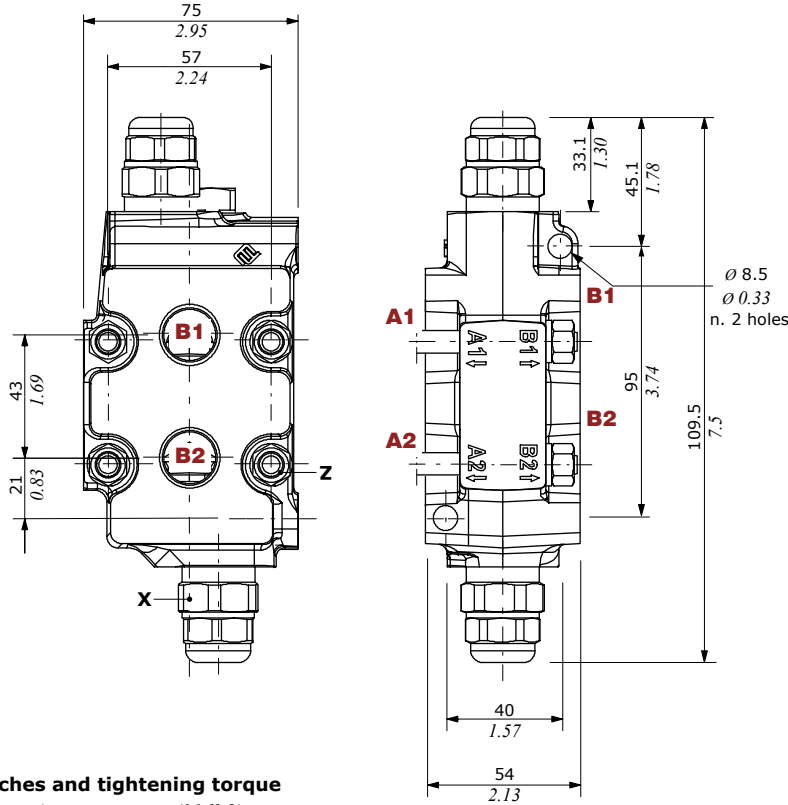

Wrenches and tightening torque
X = wrench 27 - 42 Nm (31 lbft)
Z = wrench 13 - 24 Nm (17.7 lbft)

Configuration with valve on each workport (P3)

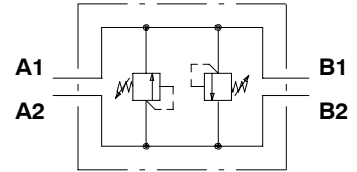

Configuration with valve on workport A (P2)

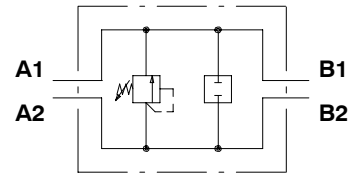

Configuration with valve on workport B (P1)

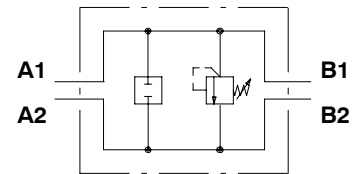

Antishock valves performance data

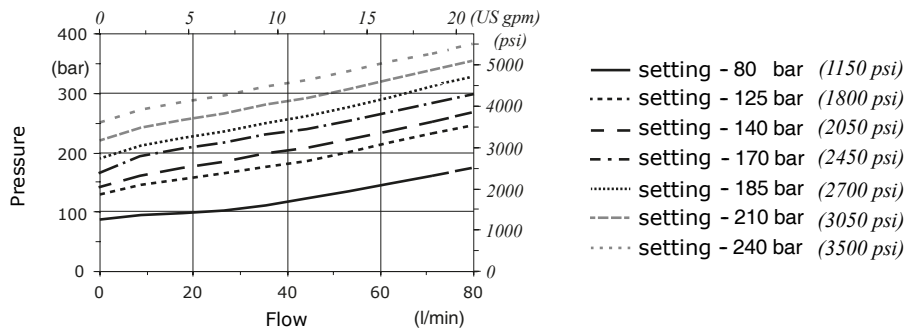

Coils and accessories

Type	Voltage	Ordering codes					Flying leads without connector
		ISO4400	Deutsch DT	AMP JPT	Packard Weatherpack	Packard Metri-pack	
D19	12 VDC	4SOL519112	4SOL519402 ⁽⁶⁾	-	-	-	-
	20 VDC	4SOL519120	-	-	-	-	-
	24 VDC	4SOL519124	4SOL519404 ⁽⁶⁾	-	-	-	-
	94 VDC	4SOL519194	-	-	-	-	-
	192 VDC	4SOL519292	-	-	-	-	-
Mating connectors		4CN1009995	5CON140031	-	-	-	-

Notes: ⁽¹⁾ supply with AC and use only with rectifier connector - ⁽²⁾ with flying leads - ⁽³⁾ with bidirectional diode - ⁽⁴⁾ with unidirectional diode ⁽⁵⁾ integrated perpendicular type - ⁽⁶⁾ integrated parallel type

Features

Nominal voltage tolerance: $\pm 10\%$
 Nominal power.....: 60 W
 12/20/24/94/192 VDC
 Nominal current.....: 5 A @ 12 VDC
 : 3 A @ 20 VDC
 : 2.5 A @ 24 VDC
 : 2.5 A @ 94 VDC
 : 0.31 A @ 192 VDC
 Insulation.....: Class H (180°C - 356 °F)
 Weather protection.....: IP65 - ISO4400
 : IP69K - Deutsch DT
 Insertion.....: 100%

ISO4400 connector

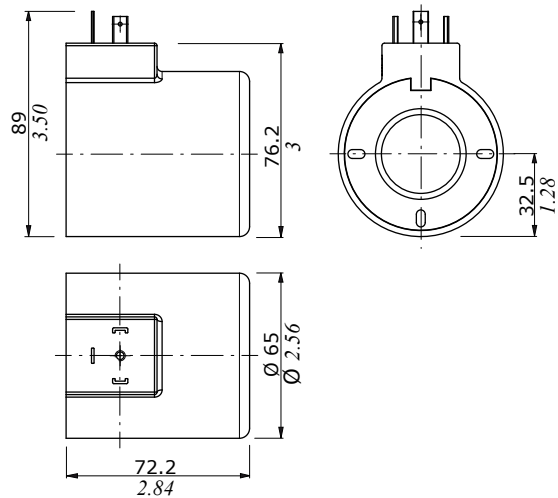

DEUTSCH DT04 connector (Parallel type)

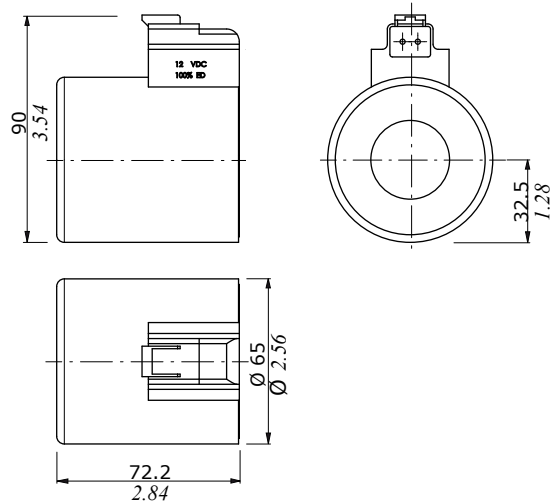



DH-DHZ

Rotary control diverter valves

- 3 - 4 - 6 - 8 ways configuration
- Galvanized body

This catalogue shows technical specifications and diagrams measured with mineral oil of 46 mm²/s (46 cSt) viscosity at 40°C - (104°F) temperature.

WORKING CONDITIONS		DHZ5	DHZ10	DHZ20	DH25	DH30
N. of available ways		3/6 - 4/8	3/6 - 4/8	3/6 - 4/8	3/6 - 4/8	3/6
Max. flow rating		60 l/min (18.5 US gpm)	90 l/min (23.7 US gpm)	140 l/min (37 US gpm)	200 l/min (52.8 US gpm)	280 l/min (74 US gpm)
Max. pressure		315 bar (4600 psi)	315 bar (4600 psi)	315 bar (4600 psi)	250 bar (3600 psi)	210 bar (3050 psi)
Internal leakage A(B)⇒T	Δp = 100 bar (1450 psi)	3 cm ³ /min (0.18 in ³ /min)	3 cm ³ /min (0.18 in ³ /min)	3 cm ³ /min (0.18 in ³ /min)	3 cm ³ /min (0.18 in ³ /min)	3 cm ³ /min (0.18 in ³ /min)
Fluid	Mineral based oil					
Fluid temperature	with NBR (BUNA-N) seals	from -20°C to 80°C (from -4°F to 176°F)				
	with FPM (VITON) seals	from -20°C to 100°C (from -4°F to 212°F)				
Viscosity	operating range	da 15 a 75 mm ² /s (from 15 to 75 cSt)				
	min.	12 mm ² /s (12 cSt)				
	max.	400 mm ² /s (400 cSt)				
Max. level of contamination		21/19/16 - ISO 4406 - NAS 1638 - class 10				
Ambient temperature for working conditions		from -40°C to 60°C (from -40°F to 140°F)				

NOTE - For different working conditions please contact Sales Dept.

Available threads

PORTS THREAD		
ALL PORTS	BSP	UN-UNF
DHZ5	G 3/8	3/4-16 (SAE 8)
DHZ10	G 1/2	7/8-14 (SAE 10)
DHZ20	G 3/4	1" 1/16-12 (SAE 12)
DH25	G 1	1" 5/16-12 (SAE 16)
DH30	G 1" 1/2	1" 7/8-12 (SAE 24)

Dimensional data and hydraulic circuit

3 - 6 ways

6-ways diverter valve is obtained by coupling two 3 way bodies with assembling kit

DHZ10 / 3 A SAE (CRZ) Galvanized body (only DHZ body)
 Serie N° ways Spool type Port type (is different from BSP)

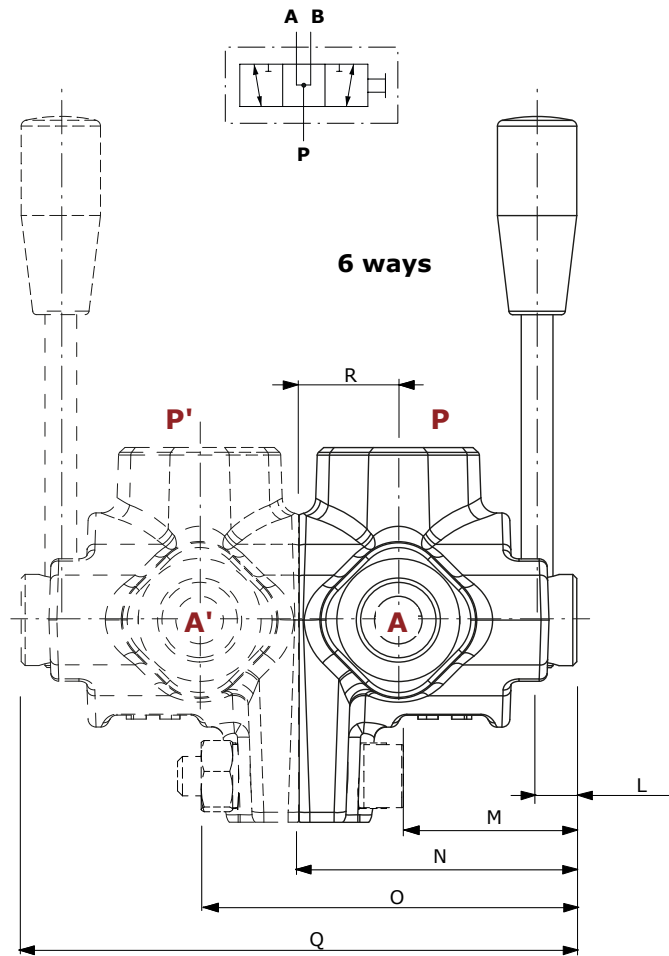
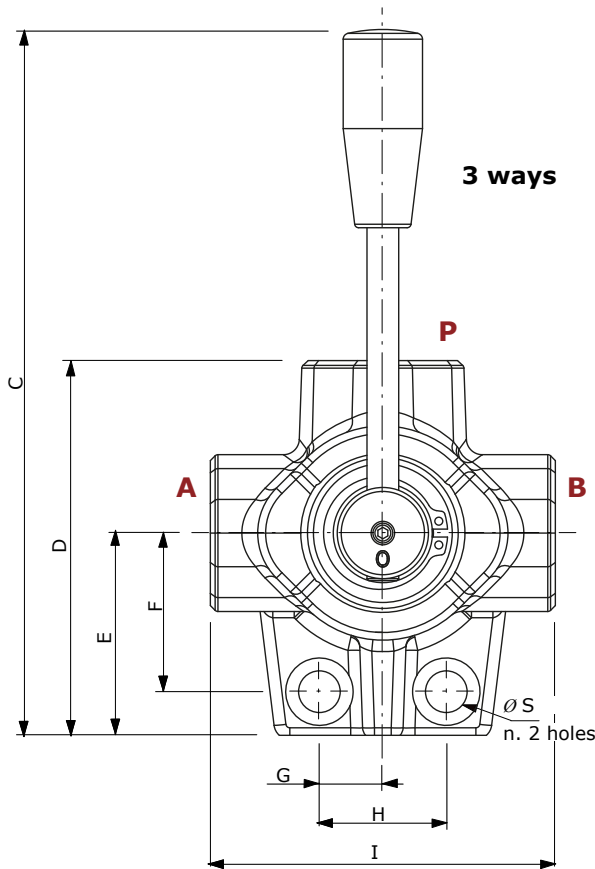

Type	C	D	E	F	G	H	I	L	M	N	O	Q	R	Ø S														
	mm* in*																											
DHZ5/3	169.5	6.67	77.5	3.05	40.5	1.59	30	1.18	12.2	0.48	24.5	0.96	74	2.91	10	0.39	42	1.65	63	2.48	-	-	21	0.83	8.5	0.33		
DHZ5/6	169.5	6.67	77.5	3.05	40.5	1.59	30	1.18	12.2	0.48	24.5	0.96	74	2.91	10	0.39	42	1.65	63	2.48	84	3.31	126	4.96	21	0.83	8.5	0.33
DHZ10/3	178	7.01	94.5	3.72	51	2.04	40	1.57	16	0.63	32	1.26	87	3.42	10	0.39	45	1.77	70	2.75	-	-	25	0.98	10.5	0.41		
DHZ10/6	178	7.01	94.5	3.72	51	2.04	40	1.57	16	0.63	32	1.26	87	3.42	10	0.39	45	1.77	70	2.75	95	3.74	140	5.51	25	0.98	10.5	0.41
DHZ20/3	196	7.72	105	4.13	60	2.36	45	1.77	16	0.63	32	1.26	92	3.62	10	0.39	48.5	1.90	78.5	3.1	-	-	30	1.18	10.5	0.41		
DHZ20/6	196	7.72	105	4.13	60	2.36	45	1.77	16	0.63	32	1.26	92	3.62	10	0.39	48.5	1.90	78.5	3.1	108.5	4.27	157	6.18	30	1.18	10.5	0.41
DH25/3	204	8.03	120	4.72	70	2.75	55	2.16	16	0.63	32	1.26	100	3.94	14	0.55	58.5	2.30	93.5	3.68	-	-	35	1.38	10.5	0.41		
DH25/6	204	8.03	120	4.72	70	2.75	55	2.16	16	0.63	32	1.26	100	3.94	14	0.55	58.5	2.30	93.5	3.68	128.5	5.06	187	7.36	35	1.38	10.5	0.41
DH30/3	284	11.18	150	5.9	85	3.35	65	2.56	24.5	0.96	49	1.93	130	5.12	15	0.59	69.5	2.74	115.5	4.55	-	-	46	1.81	10.5	0.41		
DH30/6	284	11.18	150	5.9	85	3.35	65	2.56	24.5	0.96	49	1.93	130	5.12	15	0.59	69.5	2.74	115.5	4.55	161.5	6.36	231	9.09	46	1.81	10.5	0.41

(*) - Codes are referred to **UN-UNF** thread

Dimensional data and hydraulic circuit

4 - 8 ways

8-ways diverter valve is obtained by coupling two 4 way bodies with assembling kit

DHZ10 / 4 A SAE (CRZ) Galvanized body (only DHZ body)
 Serie N° ways Spool type Port type (is different from BSP)

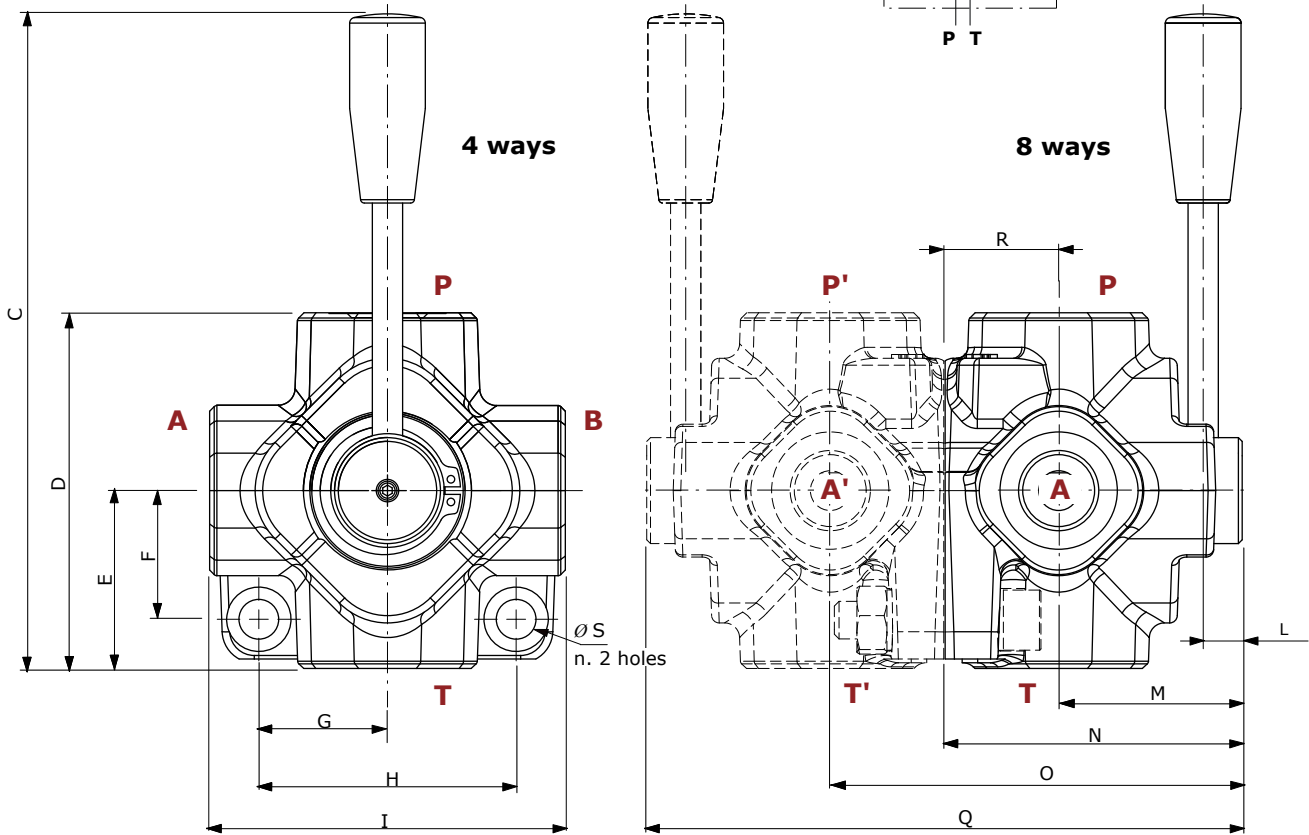

Type	C	D	E	F	G	H	I	L	M	N	O	Q	R	Ø S
	mm* in*													
DHZ5/4	167 6.57	79 3.11	39.5 1.55	27.5 1.08	27 1.06	54 2.12	79 3.11	10 0.39	45 1.77	70 2.75	-	-	25 0.98	8.5 0.33
DHZ5/8	167 6.57	79 3.11	39.5 1.55	27.5 1.08	27 1.06	54 2.12	79 3.11	10 0.39	45 1.77	70 2.75	95 3.74	140 5.51	25 0.98	8.5 0.33
DHZ10/4	173 6.81	94 3.70	47 1.85	34 1.34	34 1.33	68 3.70	94 3.70	10 0.39	48.5 1.91	78.5 3.1	-	-	30 1.18	10.5 0.41
DHZ10/8	173 6.81	94 3.70	47 1.85	34 1.34	34 1.33	68 3.70	94 3.70	10 0.39	48.5 1.91	78.5 3.1	108,5 4.27	157 6.18	30 1.18	10.5 0.41
DH20/4	185 7.28	100 3.94	50 1.97	37 1.46	37 1.45	74 2.91	100 3.94	14 0.55	61 2.40	92 3.62	-	-	31 1.22	10.5 0.41
DH20/8	185 7.28	100 3.94	50 1.97	37 1.46	37 1.45	75 2.95	100 3.94	14 0.55	61 2.40	92 3.62	123 4.84	184 7.24	31 1.22	10.5 0.41
DH25/4	251 9.88	112 4.41	56 2.2	44 1.73	44 1.73	88 3.46	112 4.41	13.5 0.53	60 2.36	95 3.74	-	-	35 1.38	10.5 0.41
DH25/8	251 9.88	112 4.41	56 2.2	44 1.73	44 1.73	88 3.46	112 4.41	13.5 0.53	60 2.36	95 3.74	130 5.12	190 7.48	35 1.38	10.5 0.41

(*) - Codes are referred to UN-UNF thread

Performance data

Pressure drop versus flow P → A(B)

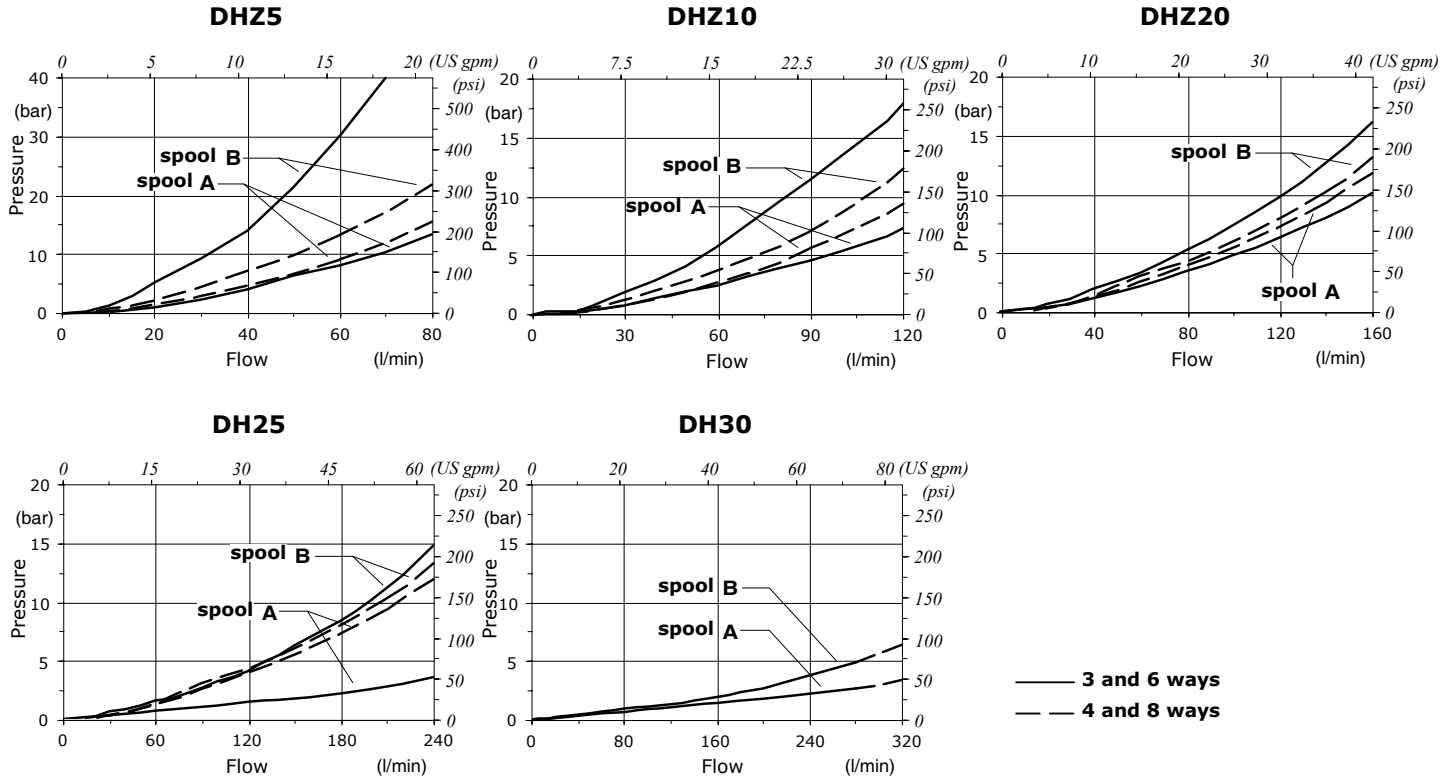

Spool circuits

3 ways

Type A
3 position,
ports connected in pos. 0

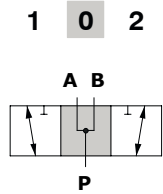

Type B
3 position,
ports closed in pos. 0

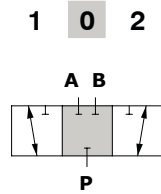

6 ways

Type A
3 position, P and P' line flow on
workports in pos. 0

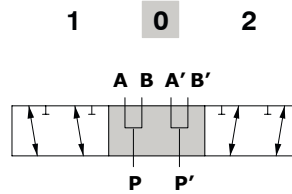

Type B
3 position,
ports closed in pos. 0

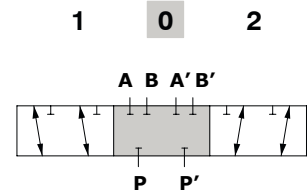

4 ways

Type A
3 position,
ports closed in pos. 0

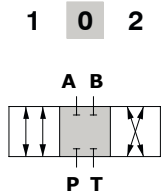

Type B
3 position, P in T,
ports closed in pos. 0

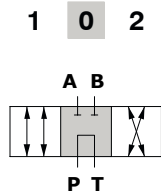

8 ways

Type A
3 position,
ports closed in pos. 0

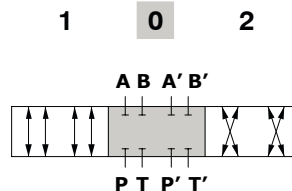

Type B
3 position, P in T, P' in T',
ports closed in pos. 0

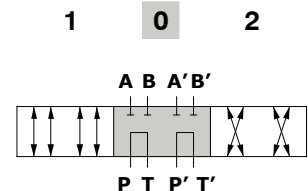

Valve ordering codes

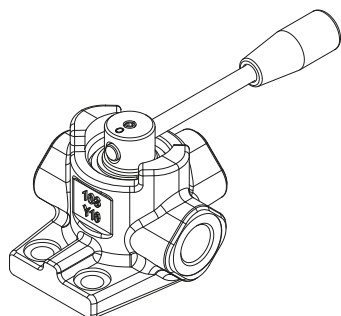

DH-DHZ.../3	
Code*	Description
132Z34110	DHZ5/3A
132Z34210	DHZ5/3B
134Z34110	DHZ10/3A
134Z34210	DHZ10/3B
136Z34110	DHZ20/3A
136Z34210	DHZ20/3B
137034110	DH25/3A
137034210	DH25/3B
139034110	DH30/3A
139034210	DH30/3B

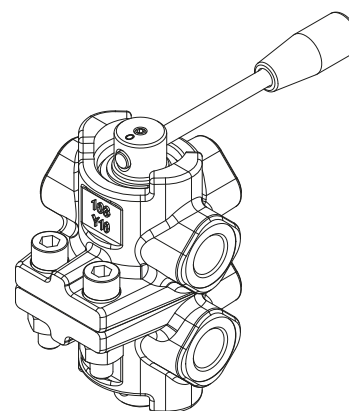

DH-DHZ.../6	
Code*	Description
132Z64110	DHZ5/6A
132Z64210	DHZ5/6B
134Z64110	DHZ10/6A
134Z64210	DHZ10/6B
136Z64110	DHZ20/6A
136Z64210	DHZ20/6B
137064110	DH25/6A
137064210	DH25/6B
139064110	DH30/6A
139061211	DH30/6B

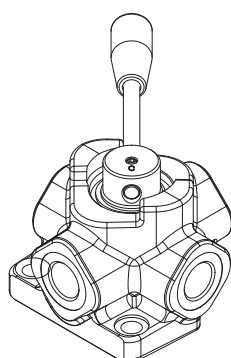

DH-DHZ.../4	
Code*	Description
132Z44110	DHZ5/4A
132Z44210	DHZ5/4B
134Z44111	DHZ10/4A
134Z44211	DHZ10/4B
136044110	DH20/4A
136044210	DH20/4B
137044110	DH25/4A
137044210	DH25/4B

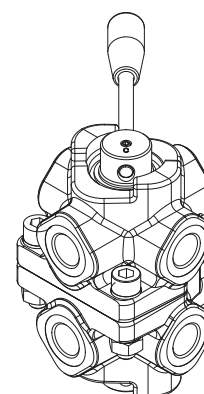

DH-DHZ.../8	
Code*	Description
132Z84110	DHZ5/8A
132Z84210	DHZ5/8B
134Z84110	DHZ10/8A
134Z84210	DHZ10/8B
136084110	DH20/8A
136081211	DH20/8B
137084110	DH25/8A
137084210	DH25/8B

(*) - Codes are referred to **UN-UNF** thread



DDF3V-S

High pressure diverter valves

- 3 ways configuration
- Galvanized body

This catalogue shows technical specifications and diagrams measured with mineral oil of 46 mm²/s - 46 cSt viscosity at 40°C - 104°F temperature.

WORKING CONDITIONS

N. of available ways	3			
	TYPE	02	03	04
Max. flow rating		60 l/min (15.9 US gpm)	90 l/min (23.8 US gpm)	120 l/min (31.7 US gpm)
Max. pressure		450 bar (6500 psi)	400 bar (5800 psi)	350 bar (5100 psi)
Internal leakage A(B)⇒T	Δp = 100 bar 1450 psi	30 cm ³ /min (0.30 in ³ /min)		
Fluid	Mineral based oil			
Fluid temperature	with NBR seals	from -20°C to 80°C (from -4°F to 176°F)		
	with FPM seals	from -20°C to 100°C (from -4°F to 212°F)		
Viscosity	operating range	da 15 a 75 mm ² /s (from 15 to 75 cSt)		
	min.	12 mm ² /s (12 cSt)		
	max.	400 mm ² /s (400 cSt)		
Level of contamination	18/16/13 - ISO 4406 - NAS 1638 - class 7			
Ambient temperature for working conditions	from -40°C to 60°C (from -40°F to 140°F)			

NOTE - For different working conditions please contact Sales Dept.

Available threads

PORTS THREAD			
Dimensions	BSP	NPT (N)	UN-UNF (S)
02	G 3/8	3/8	3/4-16 (SAE 8)
03	G 1/2	1/2	7/8-14 (SAE 10)
04	G 3/4	3/4	1" 1/16-12 (SAE 12)

Dimensional data and hydraulic circuit

3 ways

Example:

DDF3V-S 3 ways flow diverter
02 Type - dimension
A Hydraulic schema (open center)
SAE Port type - NS (is different from BSP)
... Treatment - ZN (is different from zinc-plated body)
... Lever type - LD (is different from short bent handle)

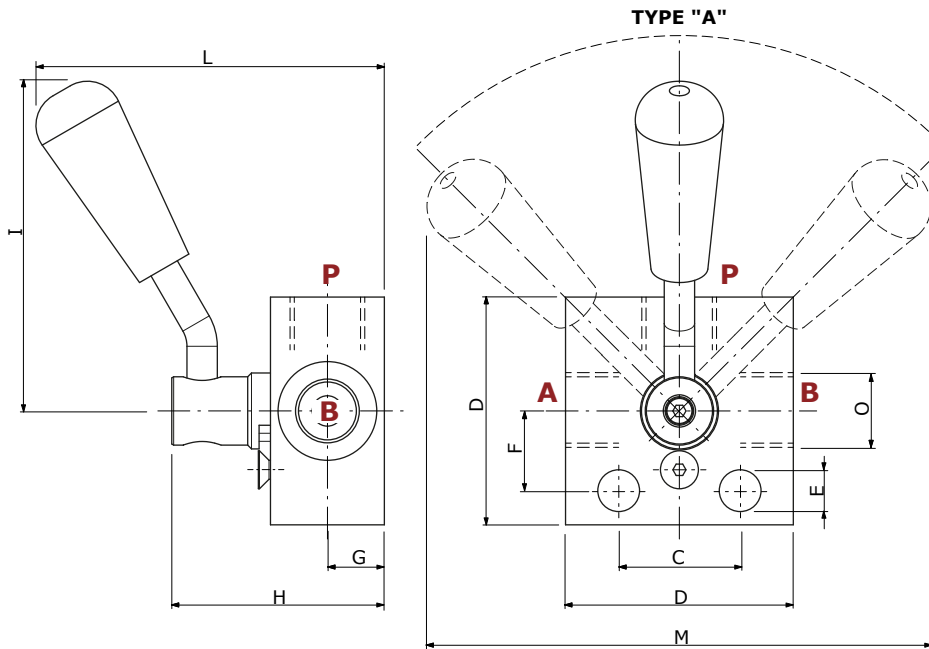
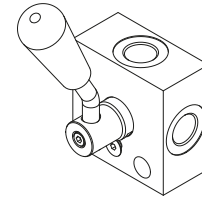

3 ways, type A
 A B and P open in pos. 0.
 Hand lever turns 90°

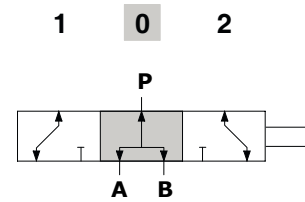

Type	C	D	Ø E	F	G	H	I	L	M	O sae
mm* - in*										
02	32 - 1.25	60 - 2.36	11 - 0.43	21 - 0.82	15 - 0.60	56 - 2.20	90 - 3.54	95 - 3.74	135 - 5.31	3/4-16
03	32 - 1.25	60 - 2.36	11 - 0.43	21 - 0.82	15 - 0.60	56 - 2.20	90 - 3.54	95 - 3.74	135 - 5.31	7/8-14
04	32 - 1.25	60 - 0.36	11 - 0.43	26 - 1.02	20 - 0.78	66 - 2.60	90 - 3.54	105 - 4.13	135 - 5.31	1" 1/16-12

(*) - Codes are referred to **UN-UNF** thread

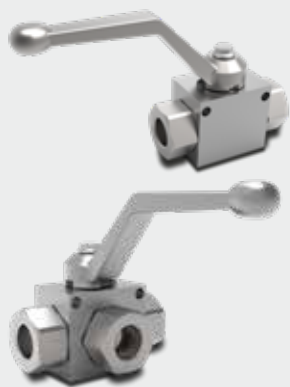

RSAP2V - RSAP3V

High pressure ball type valves

- 2 - 3 ways configuration
- Galvanized body

This catalogue shows technical specifications and diagrams measured with mineral oil of 46 mm²/s - 46 cSt viscosity at 40°C - 104°F temperature.

WORKING CONDITIONS		RSAP2V					RSAP3V*			
N. of available ways		2					3			
	TYPE	01	015	02	03	04	05	06	07	
Max. flow rating	RSAP2V	30 l/min (7.92 US gpm)	30 l/min (7.92 US gpm)	50 l/min (13.2 US gpm)	80 l/min (21.1 US gpm)	120 l/min (31.7 US gpm)	160 l/min (42.2 US gpm)	160 l/min (42.2 US gpm)	180 l/min (47.5 US gpm)	
	RSAP3V	30 l/min (7.92 US gpm)	30 l/min (7.92 US gpm)	50 l/min (13.2 US gpm)	80 l/min (21.1 US gpm)	120 l/min (31.7 US gpm)	160 l/min (42.2 US gpm)	160 l/min (42.2 US gpm)	-	
Max. pressure	RSAP2V	500 bar (7250 psi)	500 bar (7250 psi)	500 bar (7250 psi)	500 bar (7250 psi)	350 bar (5050 psi)	350 bar (5050 psi)	280 bar (4050 psi)	220 bar (3200 psi)	
	RSAP3V	380 bar (5500 psi)	380 bar (5500 psi)	380 bar (5500 psi)	320 bar (4600 psi)	300 bar (4350 psi)	280 bar (4050 psi)	240 bar (3500 psi)	-	
Nominal diameter	RSAP2V	6 mm (0.23 in)	6 mm (0.23 in)	10 mm (0.39 in)	13 mm (0.51 in)	20 mm (0.78 in)	25 mm (0.98 in)	25 mm (0.98 in)	25 mm (0.98 in)	
	RSAP3V	6 mm (0.23 in)	6 mm (0.23 in)	10 mm (0.39 in)	13 mm (0.51 in)	20 mm (0.78 in)	25 mm (0.98 in)	25 mm (0.98 in)	-	
Internal leakage A(B)⇒T	Δp = 100 bar (1450 psi)	5 cm ³ /min (0.30 in ³ /min)								
Fluid	Mineral based oil									
Fluid temperature	with NBR seals	from -20°C to 80°C (from -4°F to 176°F)								
	with FPM seals	from -20°C to 100°C (from -4°F to 212°F)								
Viscosity	operating range	da 15 a 75 mm ² /s (from 15 to 75 cSt)								
	min.	12 mm ² /s (12 cSt)								
	max.	400 mm ² /s (400 cSt)								
Level of contamination	max.	18/16/13 - ISO 4406								
Ambient temperature for working conditions	from -40°C to 60°C (from -40°F to 140°F)									

NOTE - For different working conditions please contact Sales Dept.

RSAP3V*: no back pressure admitted on the closed port

Available threads

PORTS THREAD						
Dimensions	RSAP2V			RSAP3V		
	BSP	NPT (N)	UN-UNF (S)	BSP	NPT (N)	UN-UNF (S)
01	G 1/4	1/4	-	G 1/4	1/4	-
015	-	-	9/16-18 (SAE 6)	-	-	9/16-18 (SAE 6)
02	G 3/8	3/8	3/4-16 (SAE 8)	G 3/8	3/8	3/4-16 (SAE 8)
03	G 1/2	1/2	7/8-14 (SAE 10)	G 1/2	1/2	7/8-14 (SAE 10)
04	G 3/4	3/4	1" 1/16-12 (SAE 12)	G 3/4	3/4	1" 1/16-12 (SAE 12)
05	G 1	1	1" 5/16-12 (SAE 16)	G 1	1	1" 5/16-12 (SAE 16)
06	G 1" 1/4	1" 1/4	1" 5/8-12 (SAE 20)	G 1" 1/4	1" 1/4	1" 5/8-12 (SAE 20)
07	G 1" 1/2	1" 1/2	1" 7/8-12 (SAE 24)	-	-	-

Dimensional data and hydraulic circuit

2 ways - RSAP2V

Example:

RSAP2V **01** **FF** **SAE** Port type
 (is different from BSP)
 2 way HP valve Mounting holes
 (optional)
 Type - dimension

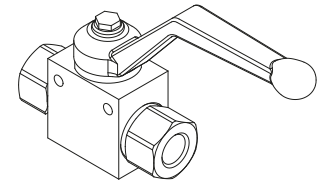
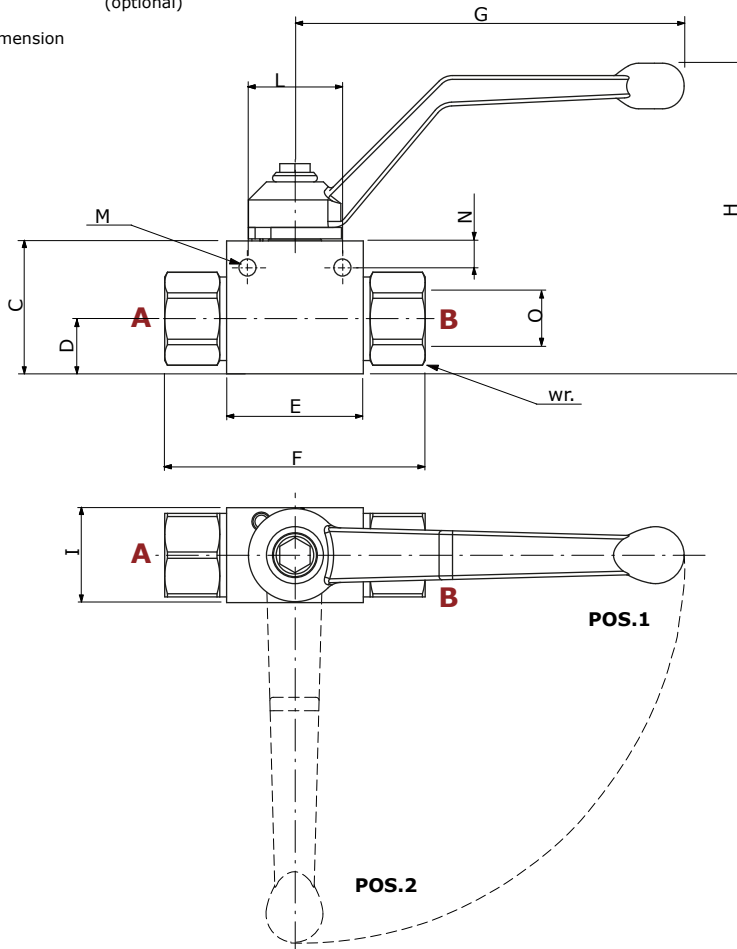

2 ways
 Open ports in pos. 1,
 closed in pos. 2

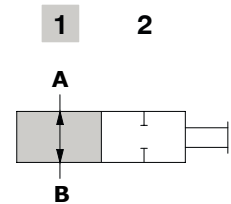

Type	C	D	E	F	G	H	I	L	Ø M	N	wr.	O sae
mm* - in*												
01	35 - 1.37	14.5 - 0.57	36 - 1.41	69 - 2.71	103 - 4.05	81 - 3.18	25 - 0.98	25 - 0.98	4.5 - 0.17	7 - 0.27	22 - 0.86	-
015	35 - 1.37	14.5 - 0.57	36 - 1.41	69 - 2.71	103 - 4.05	81 - 3.18	25 - 0.98	25 - 0.98	4.5 - 0.17	7 - 0.27	24 - 0.94	9/16-18
02	40 - 1.57	18 - 0.70	43 - 1.7	73 - 2.87	103 - 4.05	85 - 3.34	30 - 1.18	36 - 1.41	5.2 - 0.20	4 - 0.15	27 - 1.06	3/4-16
03	45 - 1.77	22 - 0.86	47 - 1.85	84 - 3.30	103 - 4.05	91 - 3.58	35 - 1.37	36 - 1.41	5.2 - 0.20	4 - 0.15	30 - 1.18	7/8-14
04	60 - 2.36	27 - 1.06	62 - 2.44	97 - 3.81	181 - 7.12	108 - 4.25	50 - 1.96	45 - 1.77	6.5 - 0.25	6.5 - 0.25	41 - 1.61	1" 1/16-12
05	60 - 2.36	25.5 - 1.00	68 - 2.67	114 - 4.48	181 - 7.12	108 - 4.25	60 - 2.36	45 - 1.77	7 - 0.27	6.5 - 0.25	46 - 1.81	1" 5/16-12
06	60 - 2.36	25.5 - 1.00	68 - 2.67	124 - 4.88	181 - 7.12	108 - 4.25	60 - 2.36	45 - 1.77	7 - 0.27	6.5 - 0.25	50 - 1.96	1" 5/8-12
07	60 - 2.36	25.5 - 1.00	68 - 2.67	132 - 5.19	181 - 7.12	108 - 4.25	60 - 2.36	45 - 1.77	7 - 0.27	6.5 - 0.25	55 - 2.16	1" 7/8-12

(*) - Codes are referred to UN-UNF thread

Dimensional data and hydraulic circuit

3 ways - RSAP3V

Example:

RSAP3V **01** **SAE** **T** Hydraulic scheme
 3 way HP valve Port type (is different from BSP)
 Type - dimension

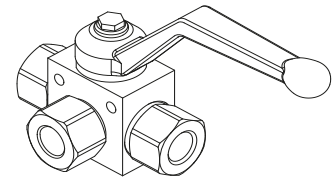
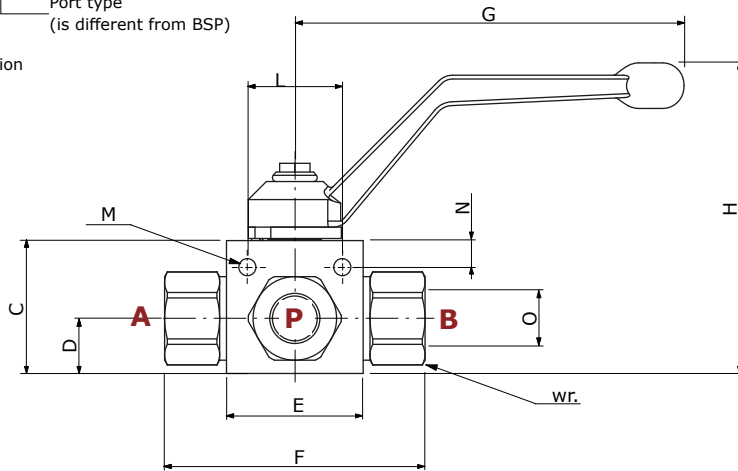

3 ways, type L

A B and P are partially closed in pos. 0. Hand lever turns 90° only

1 2

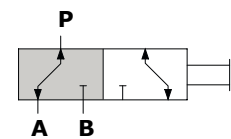

3 ways, type T

A B and P open in pos. 0. Hand lever turns 180°

1 0 2

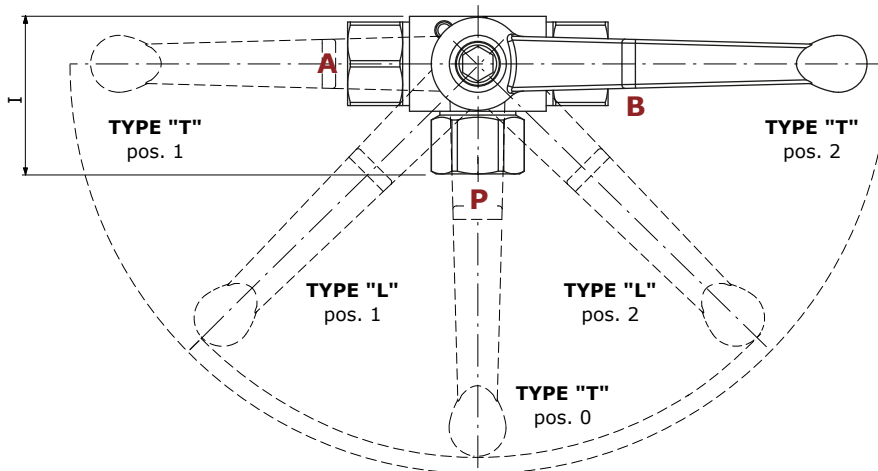
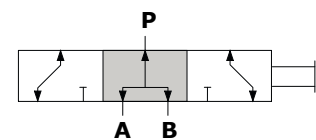

Type	C	D	E	F	G	H	I	L	Ø M	N	wr.	O sae
	mm* - in*											
01	35 - 1.37	14.5 - 0.57	36 - 1.41	69 - 2.71	103 - 4.05	81 - 3.18	41.5 - 1.63	25 - 0.98	4.5 - 0.17	7 - 0.27	22 - 0.86	-
015	35 - 1.37	14.5 - 0.57	36 - 1.41	69 - 2.71	103 - 4.05	81 - 3.18	41.5 - 1.63	25 - 0.98	4.5 - 0.17	7 - 0.27	24 - 0.94	9/16-18
02	40 - 1.57	18 - 0.70	43 - 1.7	73 - 2.87	103 - 4.05	85 - 3.34	45 - 1.77	36 - 1.41	5.2 - 0.20	4 - 0.15	27 - 1.06	3/4-16
03	45 - 1.77	22 - 0.86	47 - 1.85	84 - 3.30	103 - 4.05	91 - 3.58	54 - 2.12	36 - 1.41	5.2 - 0.20	4 - 0.15	30 - 1.18	7/8-14
04	60 - 2.36	27 - 1.06	62 - 2.44	97 - 3.81	181 - 7.12	108 - 4.25	68 - 2.47	45 - 1.77	6.5 - 0.25	6.5 - 0.25	41 - 1.61	1" 1/16-12
05	60 - 2.36	25.5 - 1.00	68 - 2.67	114 - 4.48	181 - 7.12	108 - 4.25	84 - 3.30	45 - 1.77	7 - 0.27	6.5 - 0.25	46 - 1.81	1" 5/16-12
06	60 - 2.36	25.5 - 1.00	68 - 2.67	124 - 4.88	181 - 7.12	108 - 4.25	89 - 3.50	45 - 1.77	7 - 0.27	6.5 - 0.25	50 - 1.96	1" 5/8-12

(*) - Codes are referred to UN-UNF thread

Installation and maintenance

The diverter valves are assembled and tested as per the technical specification of this catalogue.

Before the final installation on your equipment, follow the below recommendations:

- the diverter valves can be assembled in any position, in order to prevent body deformation and spool sticking mount the product on a flat surface;
- in order to prevent the possibility of water entering the lever box and spool control kit, do not use high pressure wash down directly on the diverter valves;
- prior to painting, ensure plastic port plugs are tightly in place.

Fittings tightening torque - Nm / lbft

These torque are recommended. Assembly tightening torque depends on many factors, including lubrication, coating and surface finish. The manufacturer shall be consulted.

MECHANICAL CONTROL MONOBLOCK DIVERTER VALVES

THREADS TYPE	DF5-DFC050	DF10-DFC100	DF20	DF25
BSP	G 3/8	G 1/2	G 3/4	G 1
With O-Ring seal	35/25.8	50/37	90/66.4	100/73.8
With copper washer	40/29.5	60/44.3	60/44.3	90/66.4
With steel and rubber washer	30/22	60/44.3	70/51.6	100/73.8
UN-UNF	3/4-16 (SAE 8)	7/8-14 (SAE 10)	1" 1/16-12 (SAE 12)	1" 5/16-12 (SAE 16)
With O-Ring seal	50/37	60/44.3	95/70	150/111

SOLENOID CONTROL MONOBLOCK DIVERTER VALVES

THREADS TYPE	DFE052			DFE10		DFE20		DFE085	DFE110		DFE141
	Ports	Drain	Drain*	Ports	Drain	Ports	Drain	Ports	Ports	Drain	Ports
BSP	G 3/8	G 1/4	G 1/4	G 1/2	G 1/4	G 3/4	G 1/4	G 3/8	G 1/2	G 1/4	G 1/2
With O-Ring seal	35/25.8	20/14.8	20/14.8	50/37	20/14.8	90/66.4	20/14.8	35/25.8	50/37	20/14.8	50/37
With copper washer	40/29.5	25/18.4	25/18.4	60/44.3	25/18.4	60/44.3	25/18.4	40/29.5	60/44.3	25/18.4	60/44.3
With steel and rubber washer	30/22	16/11.8	16/11.8	60/44.3	16/11.8	70/51.6	16/11.8	30/22	60/44.3	16/11.8	60/44.3
UN-UNF	3/4-16 (SAE 8)	9/16-18 (SAE 6)	7/16-20 (SAE 4)	7/8-14 (SAE 10)	9/16-18 (SAE 6)	1" 1/16-12 (SAE 12)	7/16-20 (SAE 4)	3/4-16 (SAE 8)	7/8-14 (SAE 10)	9/16-18 (SAE 6)	-
With O-Ring seal	50/37	30/22	15/11	60/44.3	30/22	95/70	15/11	50/37	60/44.3	30/22	

NOTE (*) - drain for DFE052/8

SOLENOID CONTROL SECTIONAL DIVERTER VALVES

THREADS TYPE	DFE080		DFE100		DFE140	
	Ports	Drain	Ports	Drain	Ports	Drain
BSP	G 1/4	G 1/4	G 3/8	G 1/4	G 1/2	G 1/4
With O-Ring seal	20/14.8	20/14.8	35/25.8	20/14.8	50/37	20/14.8
With copper washer	25/18.4	25/18.4	40/29.5	25/18.4	60/44.3	25/18.4
With steel and rubber washer	16/11.8	16/11.8	30/22	16/11.8	60/44.3	16/11.8
UN-UNF	7/16-20 (SAE 4)	7/16-20 (SAE 4)	7/8-14 (SAE 10)	9/16-18 (SAE 6)	7/8-14 (SAE 10)	9/16-18 (SAE 6)
With O-Ring seal	15/11	15/11	50/37	30/22	60/44.3	30/22

ROTARY CONTROL DIVERTER VALVES

THREADS TYPE	DHZ5	DHZ10	DHZ20	DH25	DH30
BSP	G 3/8	G 1/2	G 3/4	G 1	G 1" 1/2
With O-Ring seal	35/25.8	50/37	90/66.4	100/73.8	120/44.3
With copper washer	40/29.5	60/44.3	60/44.3	90/66.4	100/73.8
With steel and rubber washer	30/22	60/44.3	70/51.6	100/73.8	120/44.3
UN-UNF	3/4-16 (SAE 8)	7/8-14 (SAE 10)	1" 1/16-12 (SAE 12)	1" 5/16-12 (SAE 16)	1" 7/8-12 (SAE 24)
With O-Ring seal	50/37	60/44.3	95/70	150/111	210/155



Innovation · Continuity · Integration
————— It is Power —————

walvoil
FLUID POWER EMOTION



D1WWEG01A
1st edition January 2020

Walvoil S.P.A. • 42124 Reggio Emilia • Italy • Via Adige, 13/D • Tel. +39.0522.932411 • Fax +39.0522.300984
www.walvoil.com

